



US00D475264S

(12) **United States Design Patent**  
**Kondo et al.**

(10) **Patent No.:** **US D475,264 S**

(45) **Date of Patent:** **\*\* Jun. 3, 2003**

(54) **PORTABLE ELECTRIC JIGSAW**  
(75) Inventors: **Masaki Kondo, Anjo (JP); Hiroto Inayoshi, Anjo (JP); Shinsuke Okuda, Anjo (JP)**

D414,094 S \* 9/1999 Heun ..... D8/64  
D420,876 S \* 2/2000 Bosten et al. .... D8/64  
D423,314 S \* 4/2000 Robson ..... D8/64  
D440,474 S \* 4/2001 Heun ..... D8/64  
D451,356 S \* 12/2001 Pretzell ..... D8/64  
D463,963 S \* 10/2002 Metaxatos et al. .... D8/64

(73) Assignee: **Makita Corporation, Aichi-ken (JP)**

**FOREIGN PATENT DOCUMENTS**

(\*\*) Term: **14 Years**

JP 752030 1/1989  
JP 919065 2/1995  
JP 982554 6/1997  
JP 982554-1 11/1997

(21) Appl. No.: **29/158,314**

(22) Filed: **Apr. 3, 2002**

\* cited by examiner

(30) **Foreign Application Priority Data**

Oct. 11, 2001 (JP) ..... 2001-033584

*Primary Examiner*—Doris V. Coles  
*Assistant Examiner*—Elizabeth Albert

(51) **LOC (7) Cl.** ..... **08-03**

(52) **U.S. Cl.** ..... **D8/64**

(74) *Attorney, Agent, or Firm*—Dennison, Schultz & Dougherty

(58) **Field of Search** ..... D8/61, 62, 63,  
D8/64, 69, 70; 30/272.1, 374, 375, 376,  
377, 388, 392, 393, 394, 500; 173/15, 47,  
48, 109, 169, 170, 216, 217; 310/47, 50;  
408/241 R, 241 S

(57) **CLAIM**

The ornamental design for a portable electric jigsaw, as shown and described.

(56) **References Cited**

**DESCRIPTION**

**U.S. PATENT DOCUMENTS**

3,863,342 A \* 2/1975 Griffies et al. .... 30/393  
D262,472 S \* 12/1981 Wildman ..... D8/64  
5,205,043 A \* 4/1993 Batt et al. .... 30/393  
D339,276 S \* 9/1993 Matsuoka et al. .... D8/64  
5,535,520 A \* 7/1996 Armstrong ..... 30/375  
5,634,277 A \* 6/1997 Wada et al. .... 30/392  
D404,274 S \* 1/1999 Ogasawara et al. .... D8/64  
D409,469 S \* 5/1999 Niwa et al. .... D8/69  
D410,183 S \* 5/1999 Thomson ..... D8/69

FIG. 1 is a perspective view of a portable electric jigsaw showing our new design.

FIG. 2 is a front elevation view thereof;  
FIG. 3 is a rear elevation view thereof;  
FIG. 4 is a left side elevation view thereof;  
FIG. 5 is a right side elevation view thereof;  
FIG. 6 is a top plan view thereof; and,  
FIG. 7 is a bottom view thereof.

**1 Claim, 7 Drawing Sheets**

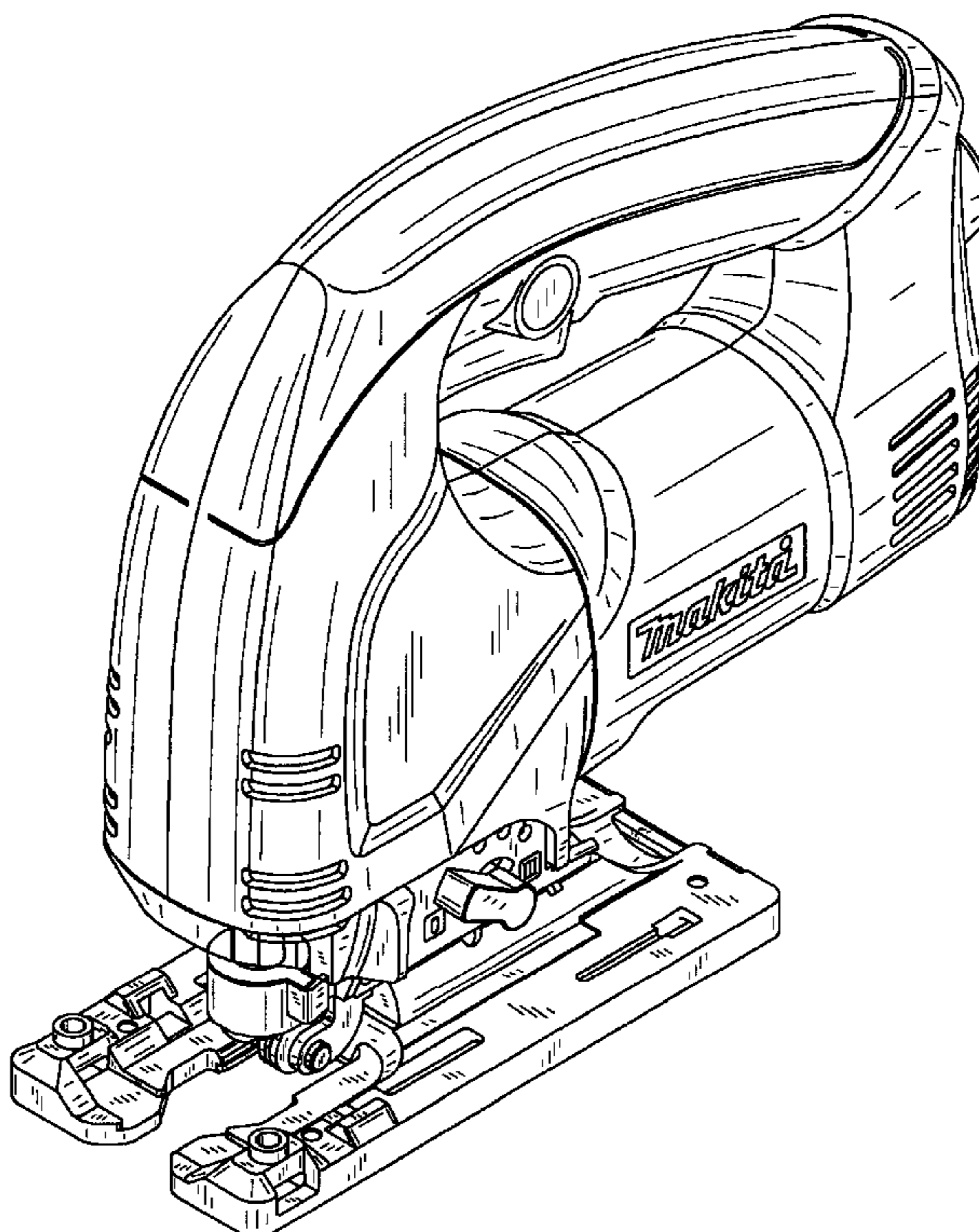

FIG. 1

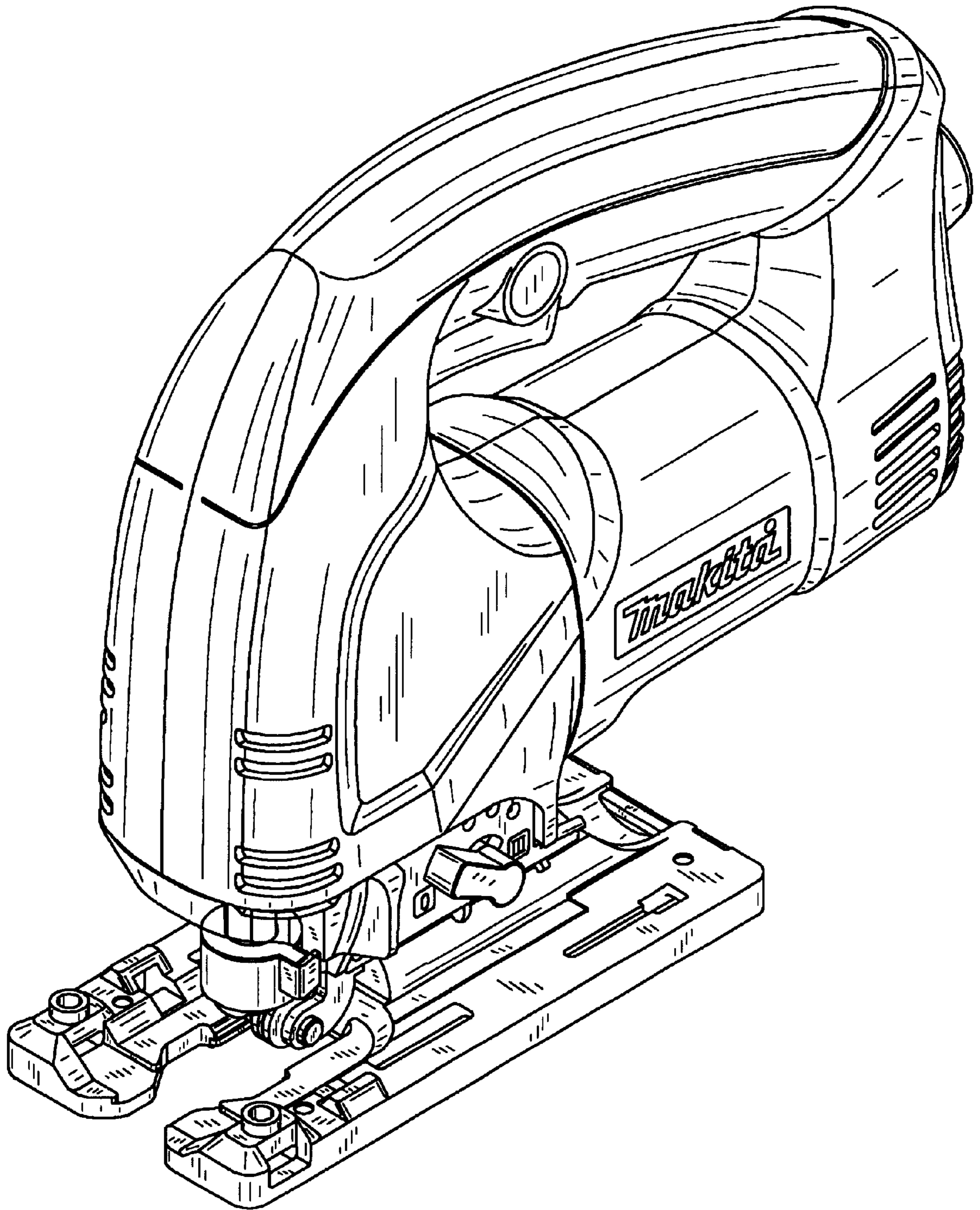

FIG. 2

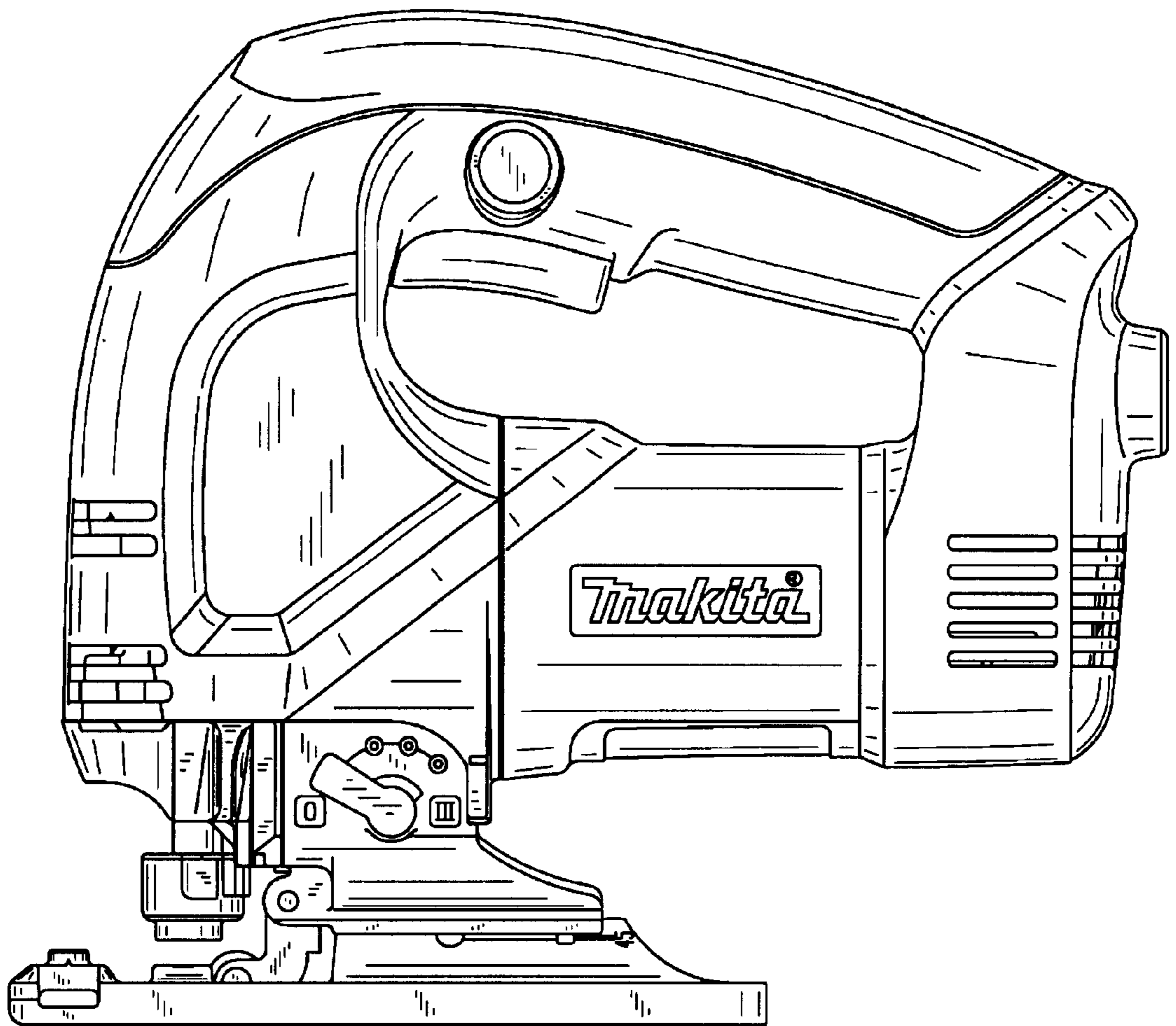



FIG. 3

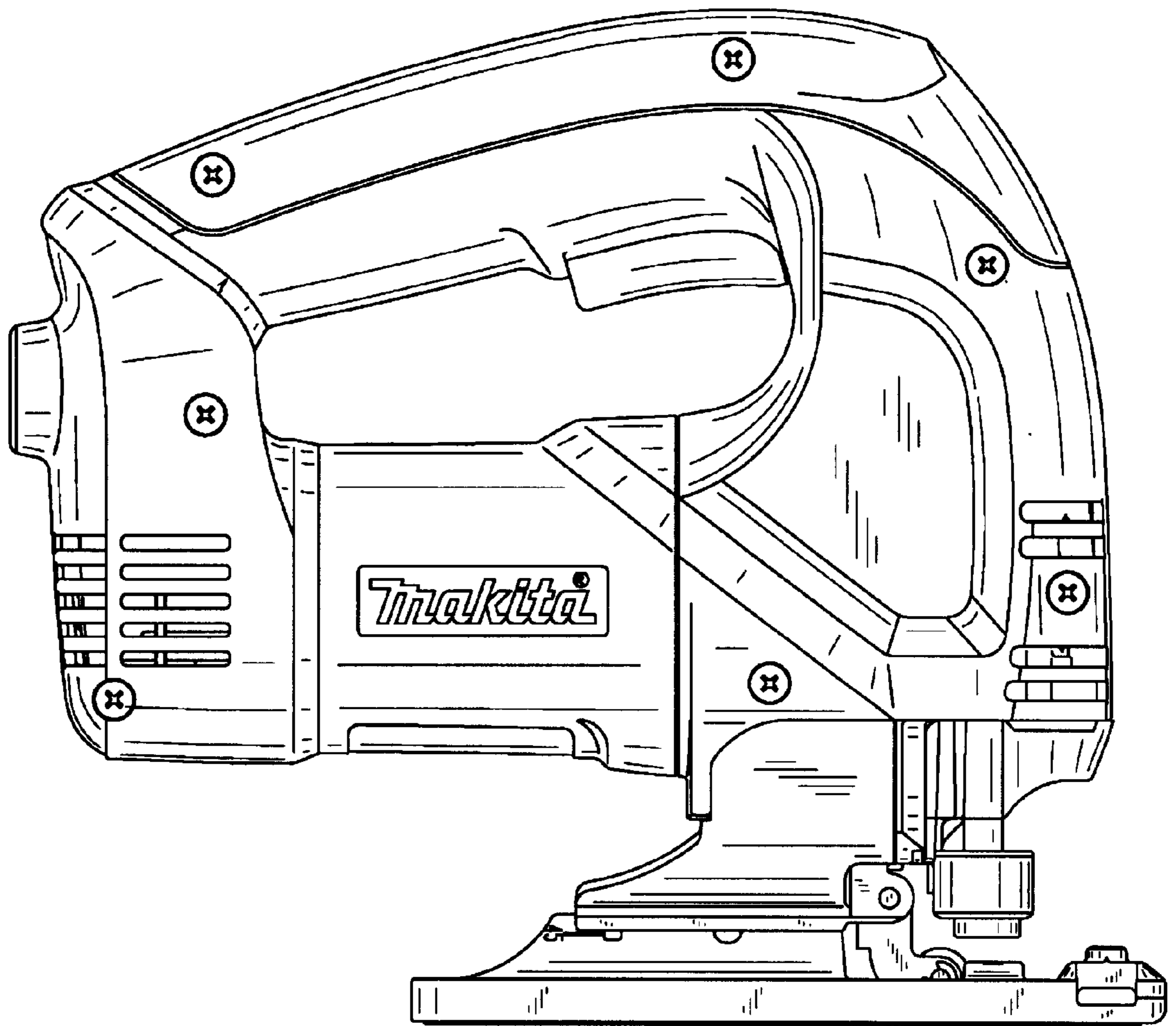
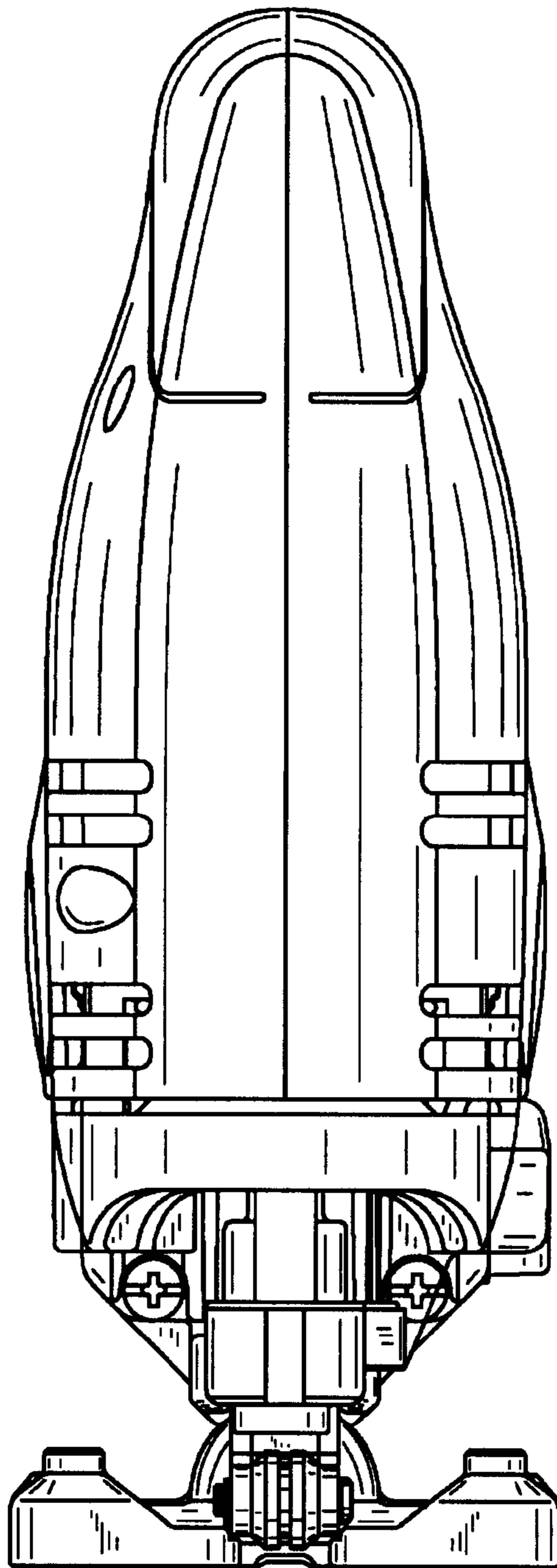

FIG. 4



# FIG. 5

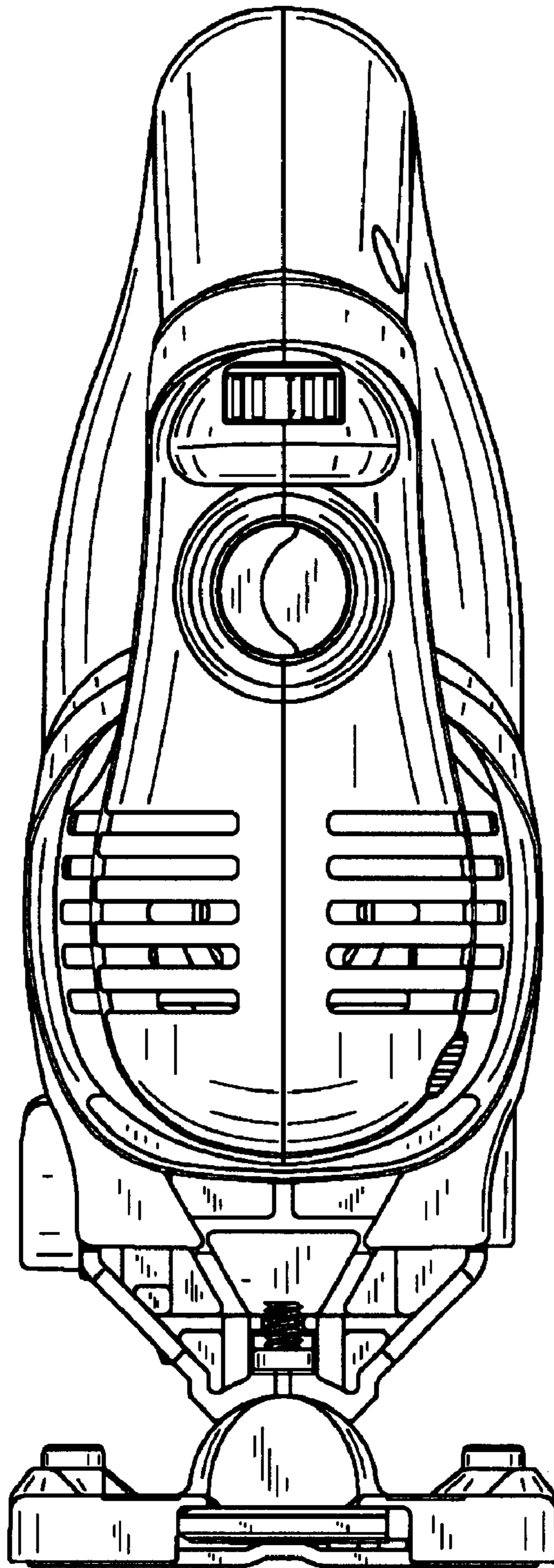

FIG. 6

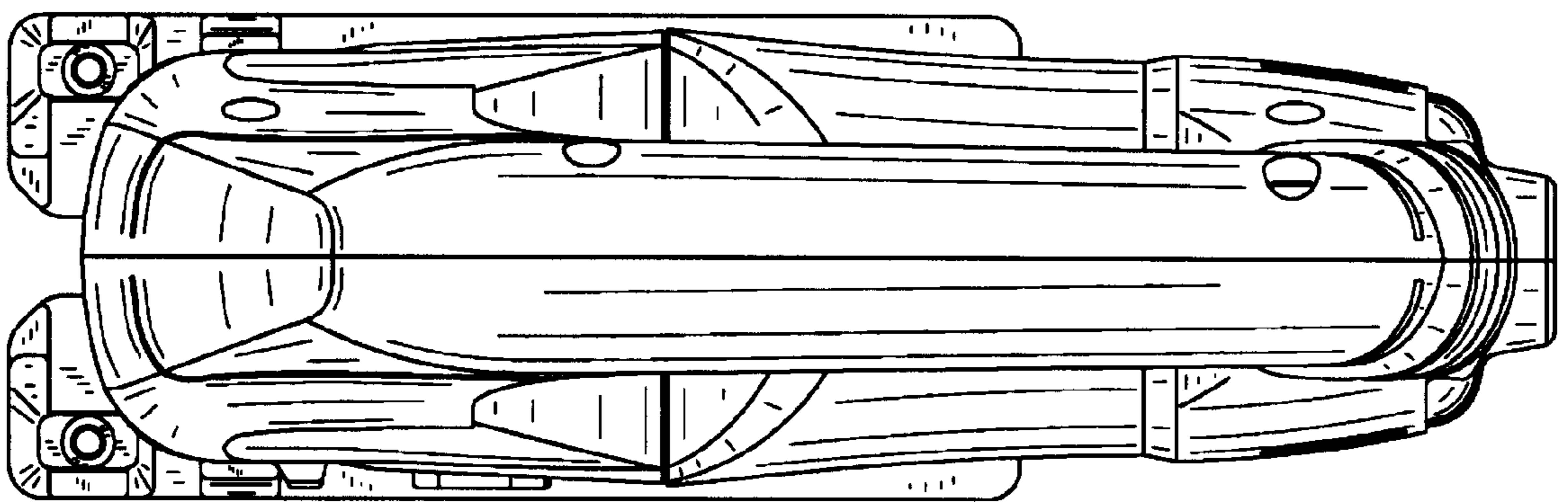

FIG. 7

