



US00D475001S

(12) **United States Design Patent**
Roll

(10) **Patent No.:** **US D475,001 S**

(45) **Date of Patent:** **** May 27, 2003**

(54) **CONTROL ARM FOR AN ALL TERRAIN VEHICLE**

6,164,673 A * 12/2000 Matsuura 280/124.101

* cited by examiner

(75) Inventor: **Douglas Roll**, Escondido, CA (US)

Primary Examiner—Joel Sincavage

(73) Assignee: **Roll Design, Inc.**, Calimesa, CA (US)

Assistant Examiner—Linda Brooks

(**) Term: **14 Years**

(74) *Attorney, Agent, or Firm*—John F. Feldsted

(21) Appl. No.: **29/155,180**

(57) **CLAIM**

(22) Filed: **Feb. 7, 2002**

The ornamental design for a control arm for an all terrain vehicle, as shown and described.

(51) **LOC (7) Cl.** **12-16**

DESCRIPTION

(52) **U.S. Cl.** **D12/159**

(58) **Field of Search** D12/107, 114,
D12/117, 159, 160; 280/124.101, 124.102,
124.138, 124.134–124.136, 124.179, 124.153,
788, 798; 180/311

FIG. 1 is a frontal perspective view;
FIG. 2 is a left side view;
FIG. 3 is a top plan view;
FIG. 4 is a right side view;
FIG. 5 is a bottom view;
FIG. 6 is a view from the kingpin bearing end; and,
FIG. 7 is a view looking in the direction of the kingpin bearing end.

(56) **References Cited**

U.S. PATENT DOCUMENTS

5,516,130 A * 5/1996 Mitchell 280/124.134

1 Claim, 5 Drawing Sheets

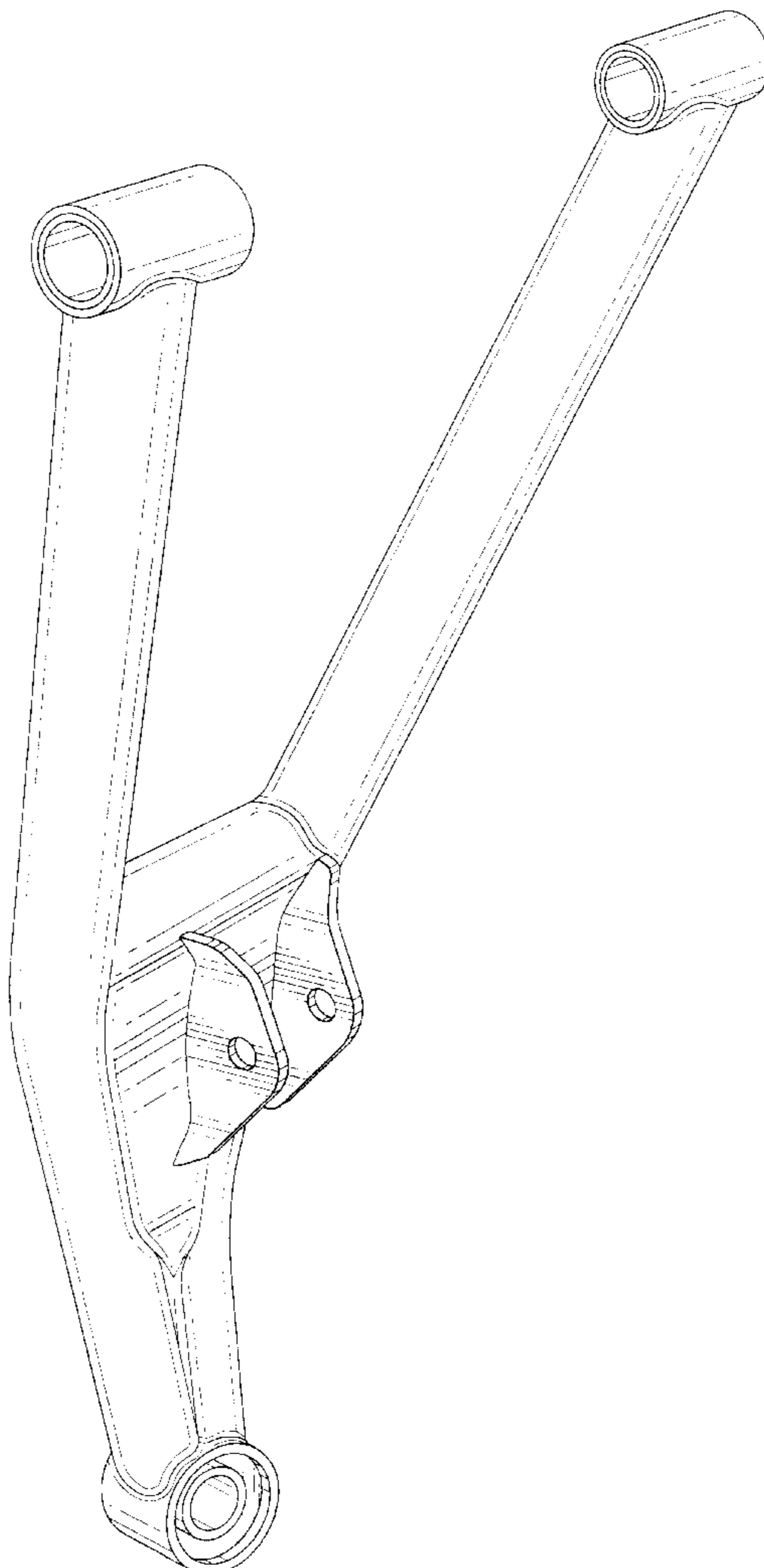

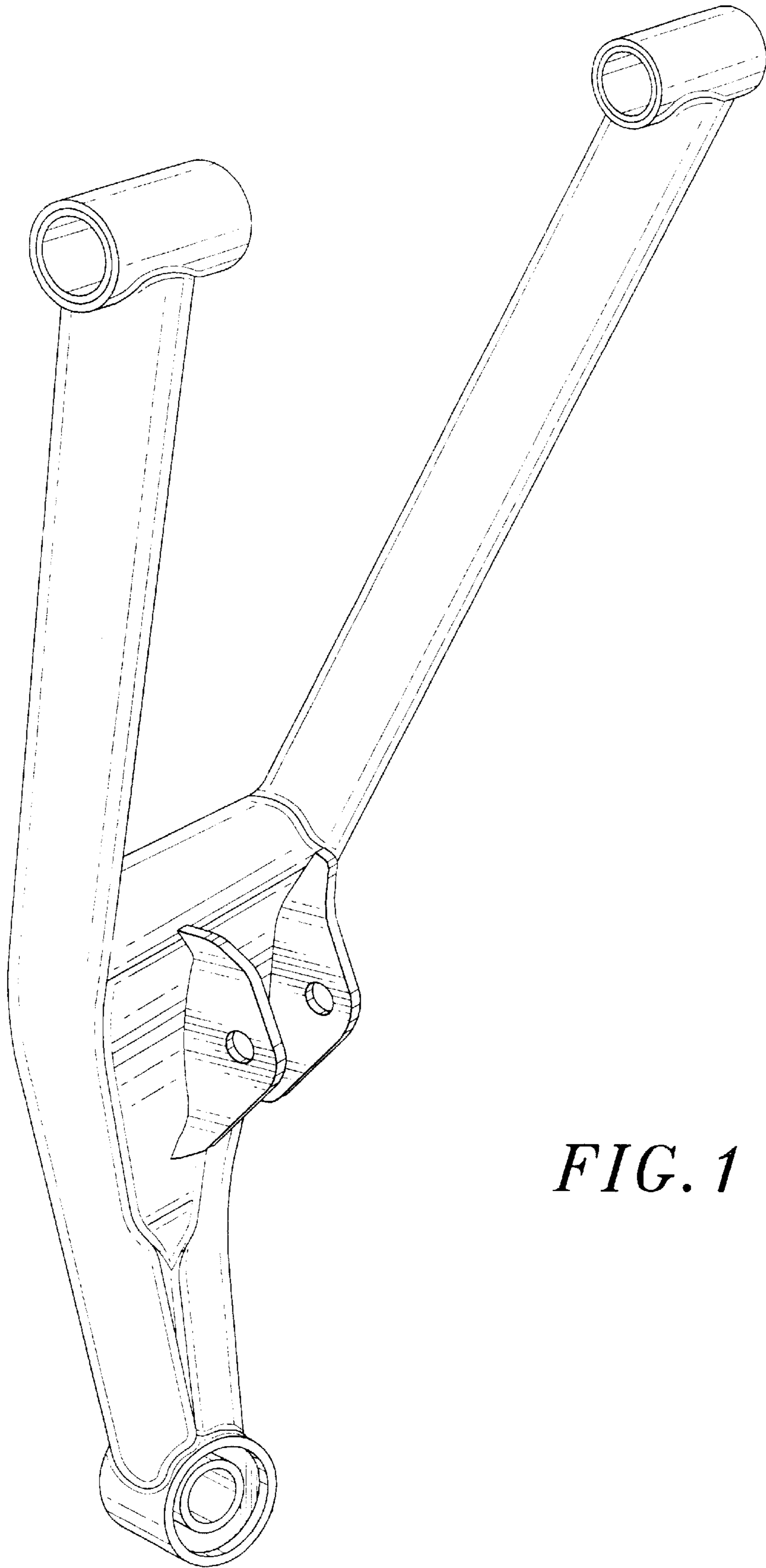

FIG. 1

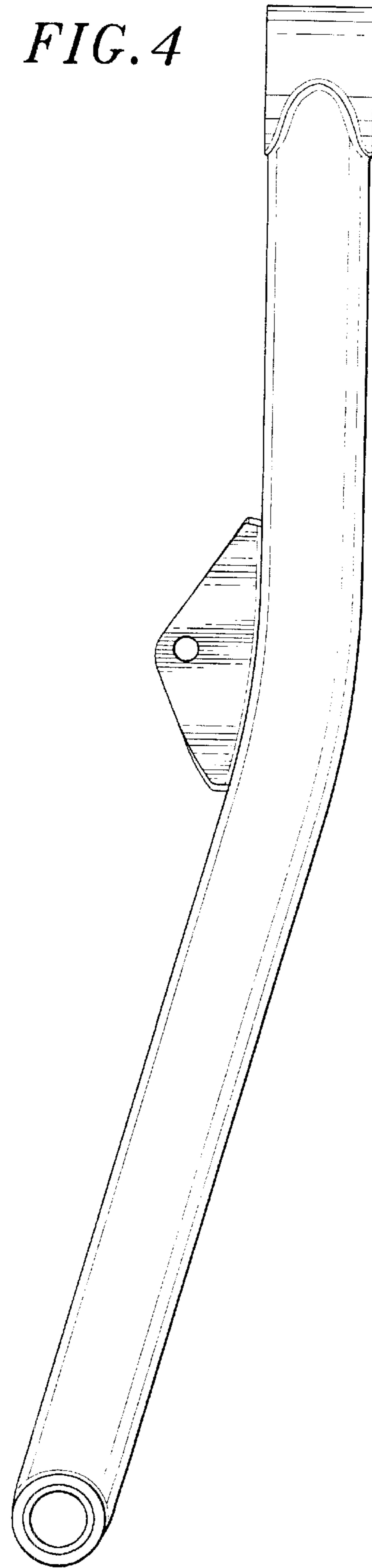
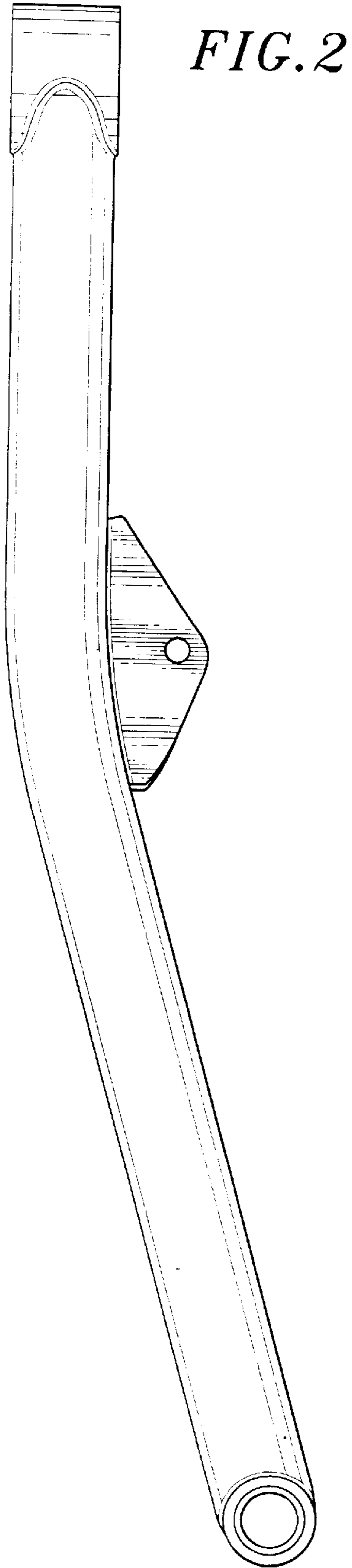

FIG. 3

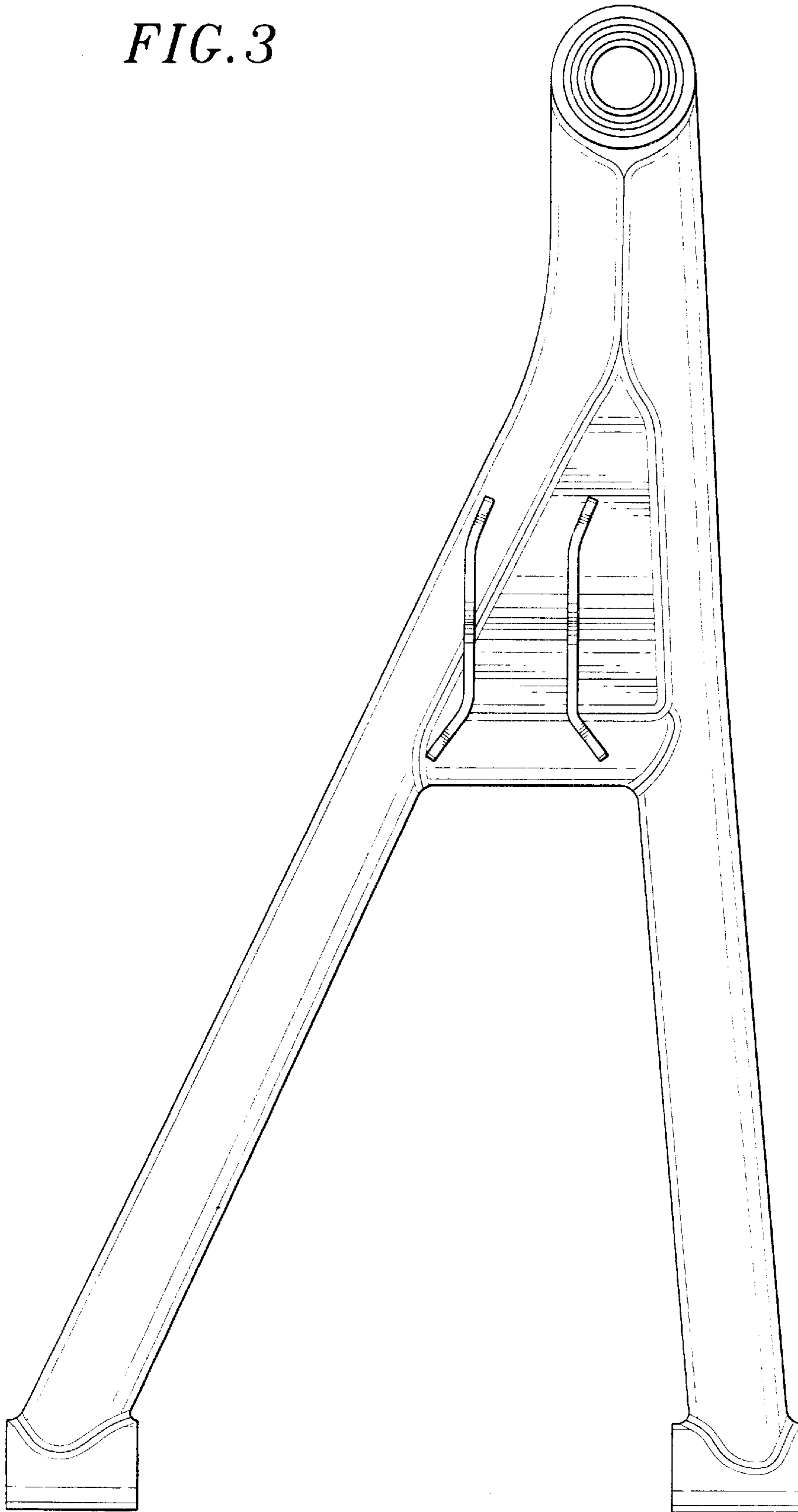

FIG. 5

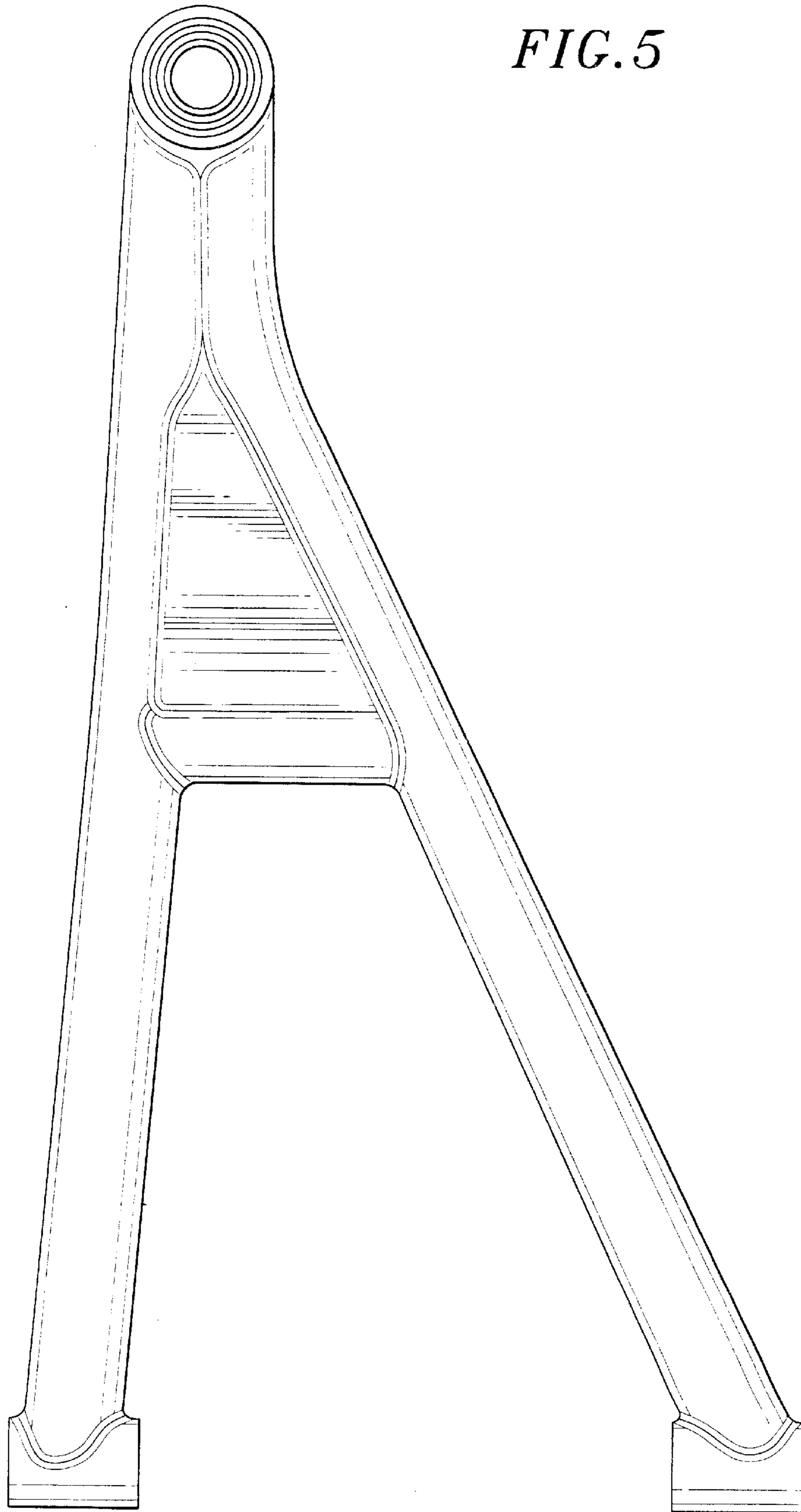

FIG. 6

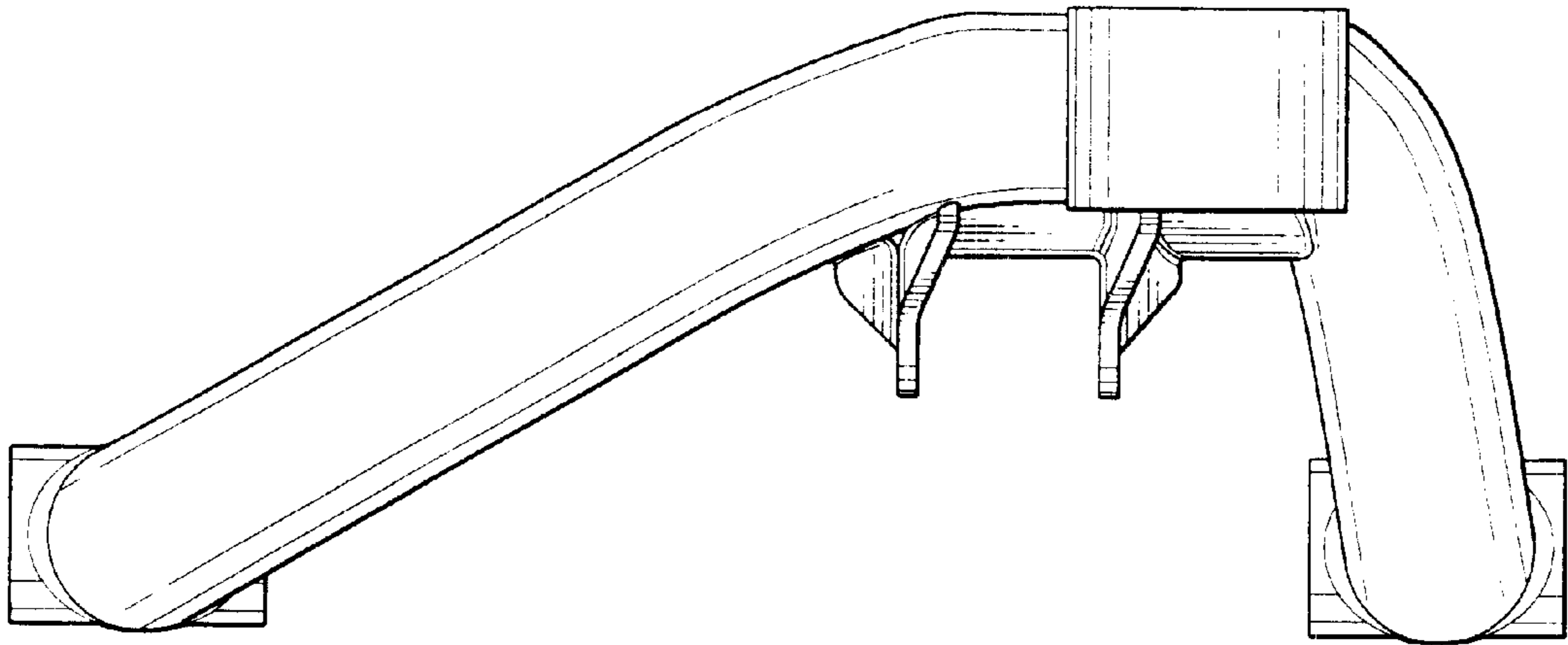

FIG. 7

