



US00D474998S

(12) **United States Design Patent**  
**Green**

(10) **Patent No.:** **US D474,998 S**

(45) **Date of Patent:** **\*\* May 27, 2003**

(54) **MOTORCYCLE AUDIO SYSTEM HOUSING**

(76) **Inventor:** **Robert Bradley Green**, P.O. Box 235,  
Surrey, British Columbia (CA), V6T  
4W8

(\*\*) **Term:** **14 Years**

(21) **Appl. No.:** **29/154,074**

(22) **Filed:** **Jan. 18, 2002**

(51) **LOC (7) Cl.** ..... **12-11**

(52) **U.S. Cl.** ..... **D12/114**

(58) **Field of Search** ..... D12/110, 114;  
D14/157; 180/219, 90; 280/288.9; 296/37.1,  
70

D266,409 S	10/1982	Hoese
D268,403 S	3/1983	Masterson
4,436,350 A	3/1984	Jolin
D275,382 S	9/1984	Hoese
D276,903 S	12/1984	Hoese
D278,328 S	4/1985	Hoese
D281,871 S	12/1985	Heiman
5,159,712 A	10/1992	Schneider et al.
D345,534 S	3/1994	Abboud et al.
D356,301 S	3/1995	Schneider et al.
D440,910 S	4/2001	Blackburn, Jr.

*Primary Examiner*—Alan P. Douglas

*Assistant Examiner*—Linda Brooks

(74) *Attorney, Agent, or Firm*—Oyen Wiggs Green & Mutala

(57) **CLAIM**

The ornamental design for a motorcycle audio system housing, as shown and described.

(56) **References Cited**

**U.S. PATENT DOCUMENTS**

2,588,671 A	3/1952	Tringali
D238,864 S	2/1976	Masterson
D240,296 S	6/1976	Dixson
D242,853 S	12/1976	Dixson
D242,997 S	1/1977	Dixson
D242,998 S	1/1977	Dixson
D245,003 S	7/1977	Fritts et al.
D251,120 S	2/1979	Hoese
D255,894 S	7/1980	Dixson
D256,115 S	7/1980	Dixson
D257,142 S	9/1980	Dixson
D257,967 S	1/1981	Hoese
D257,971 S	1/1981	Hoese
D260,628 S	9/1981	McKeel
D263,577 S	3/1982	Hoese

**DESCRIPTION**

FIG. 1 is a perspective view of the design from the upper right;  
FIG. 2 is a front view of the design;  
FIG. 3 is a top view of the design;  
FIG. 4 is a bottom view of the design;  
FIG. 5 is a right side view of the design, the left side view being a mirror image thereof;  
FIG. 6 is a perspective view of the design from below, front;  
FIG. 7 is a rear perspective view from above; and,  
FIG. 8 is a rear perspective view from below.

**1 Claim, 4 Drawing Sheets**

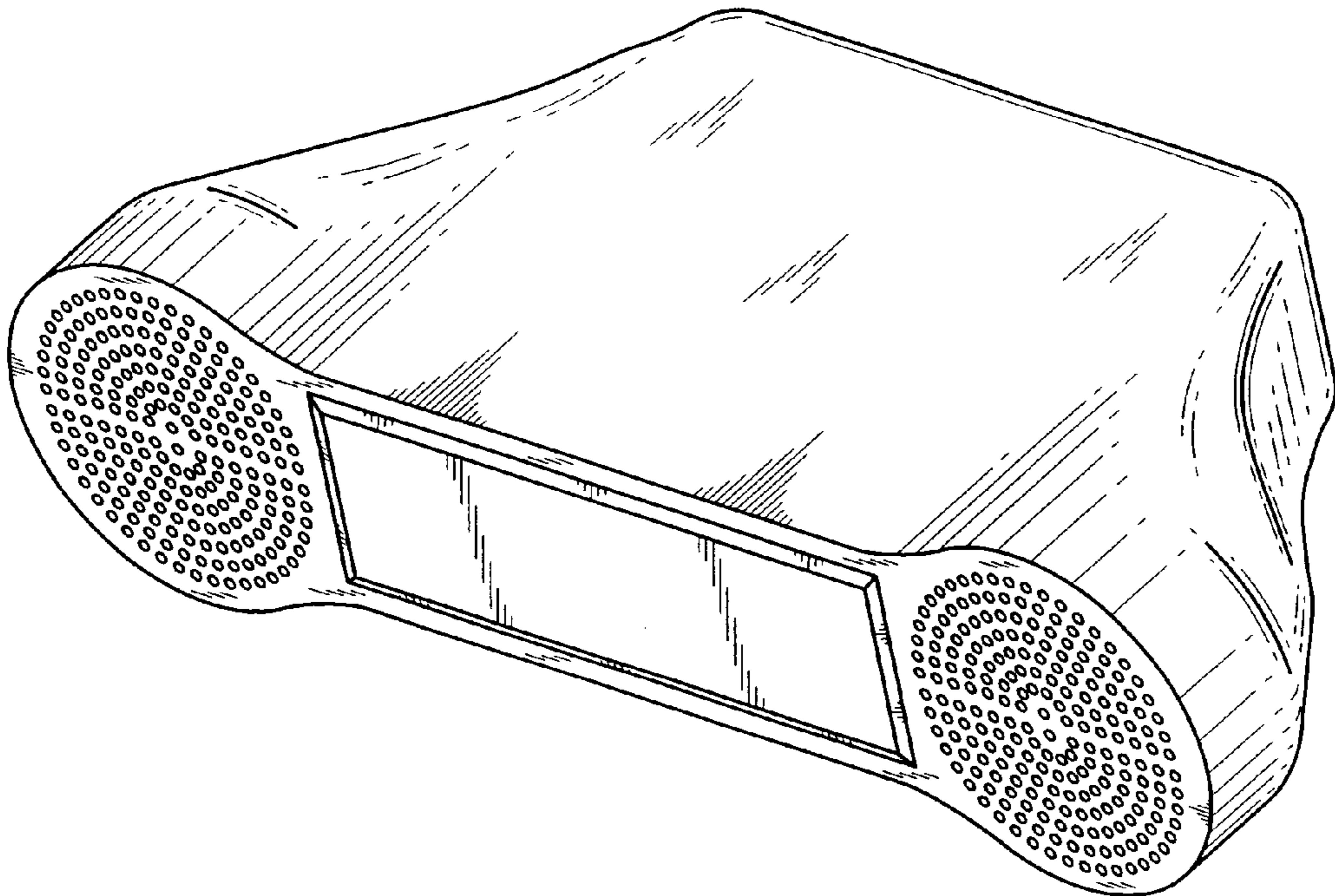

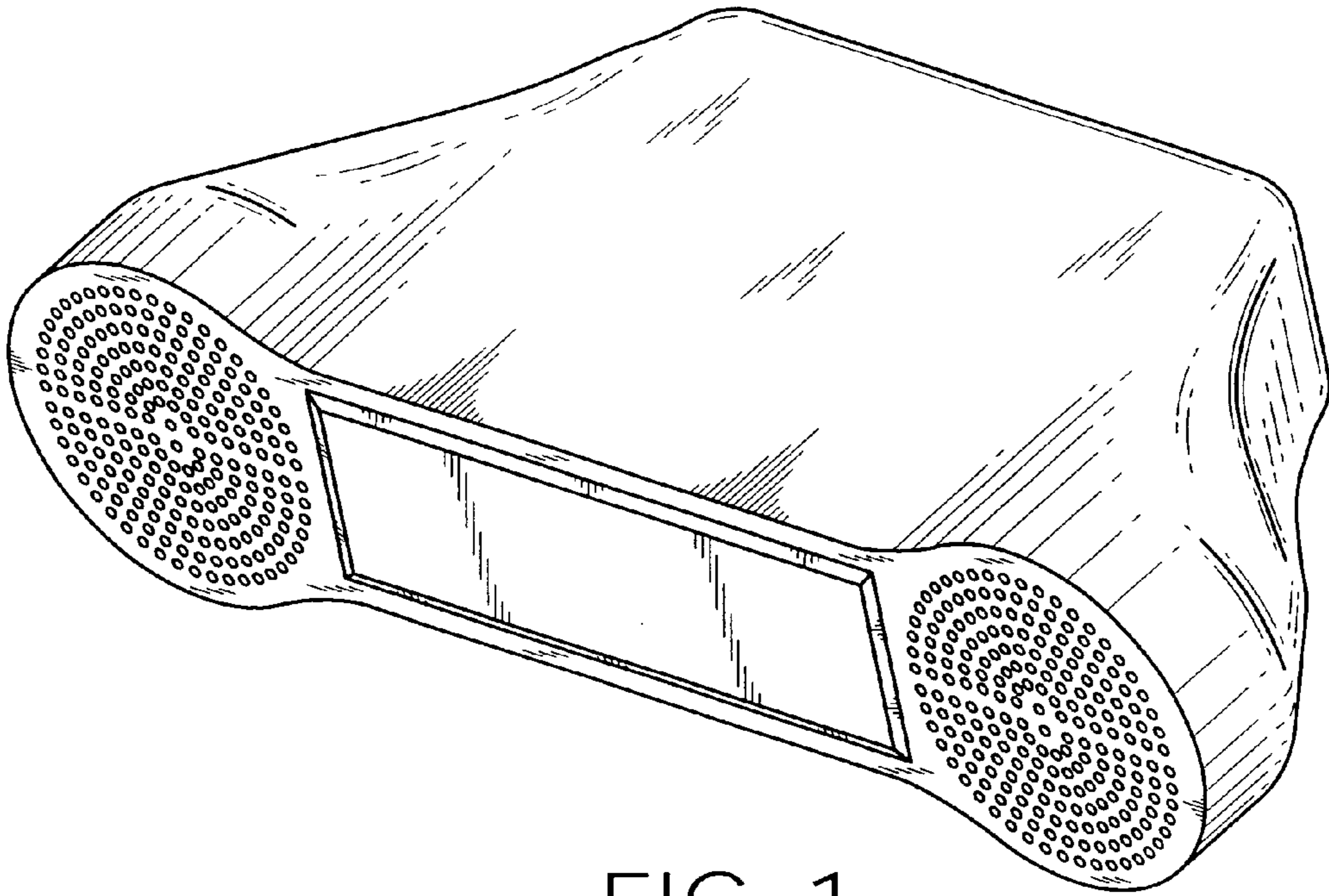

FIG. 1

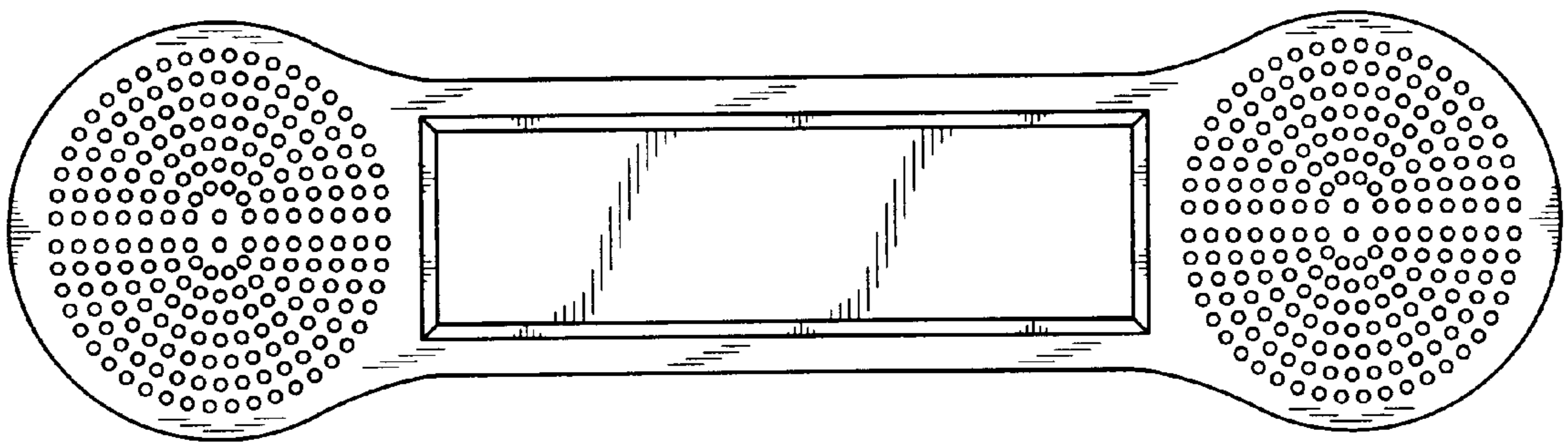

FIG. 2

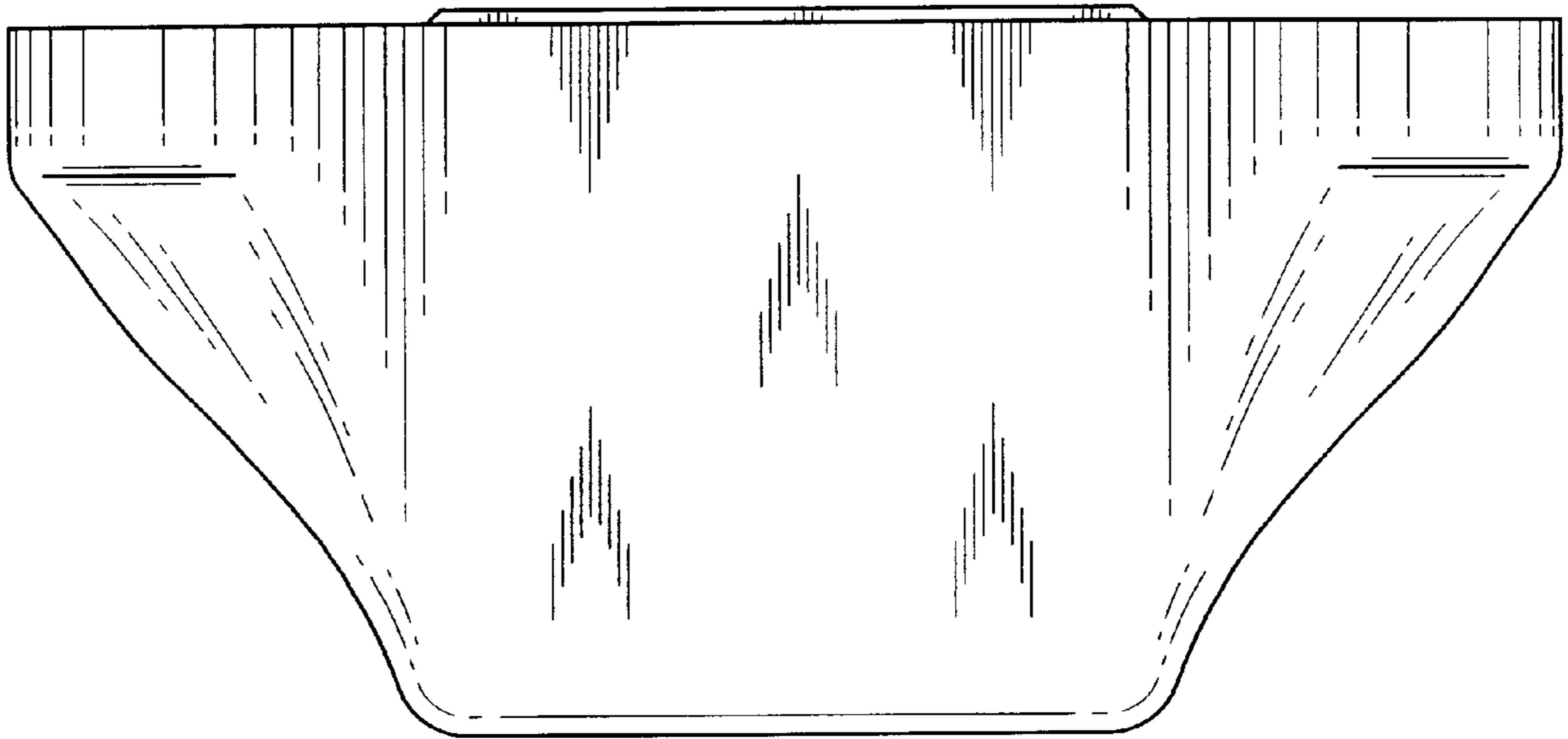

FIG. 3

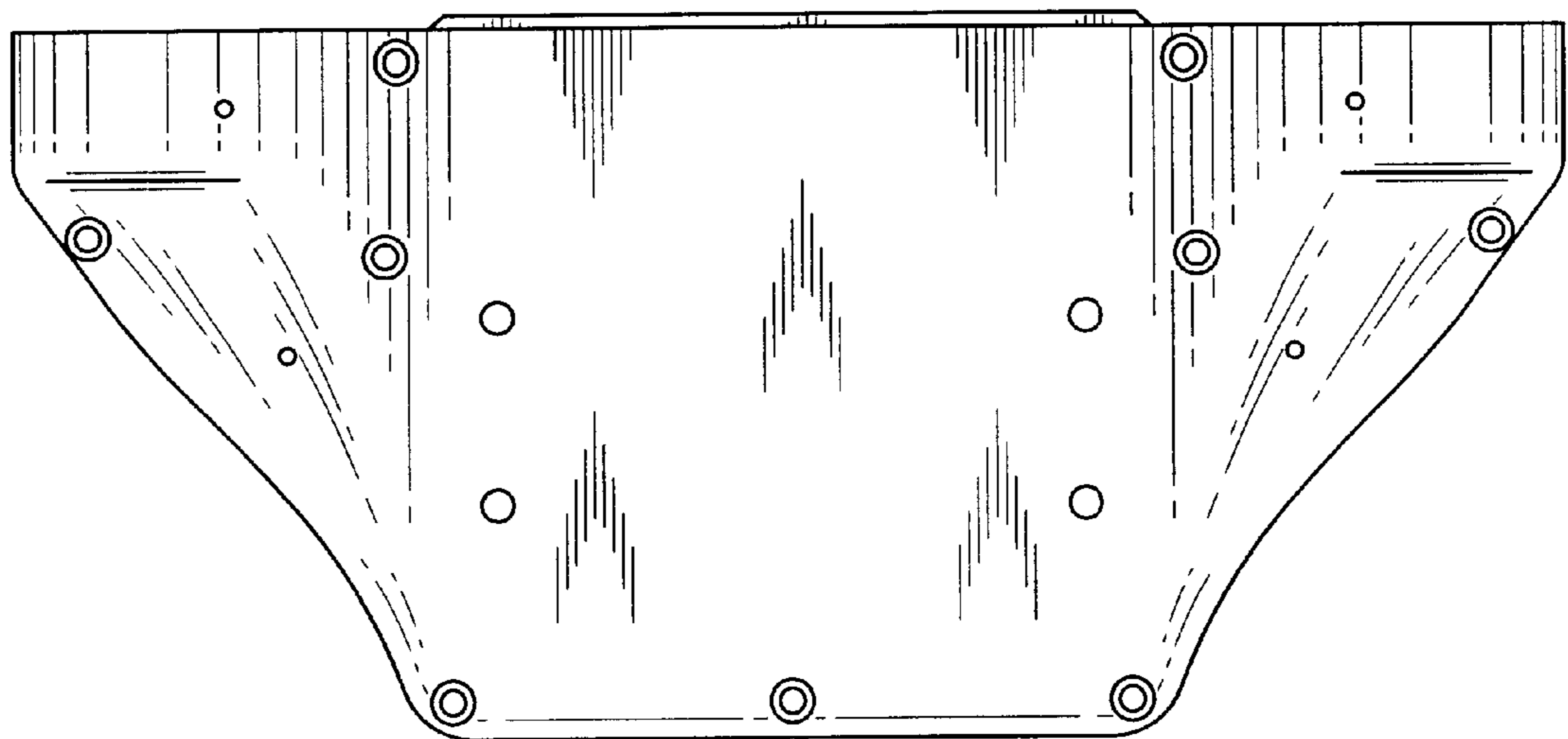

FIG. 4

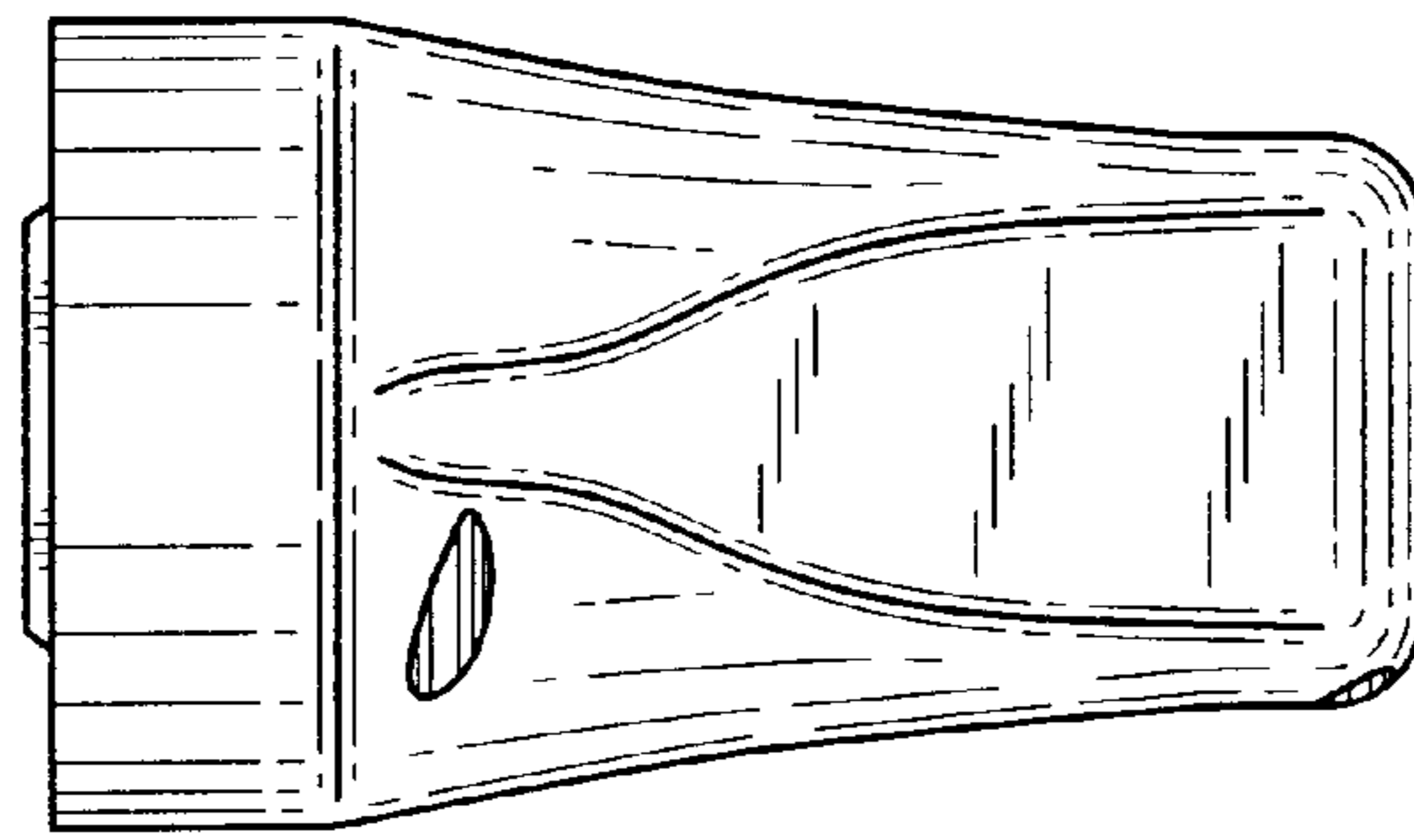

FIG. 5

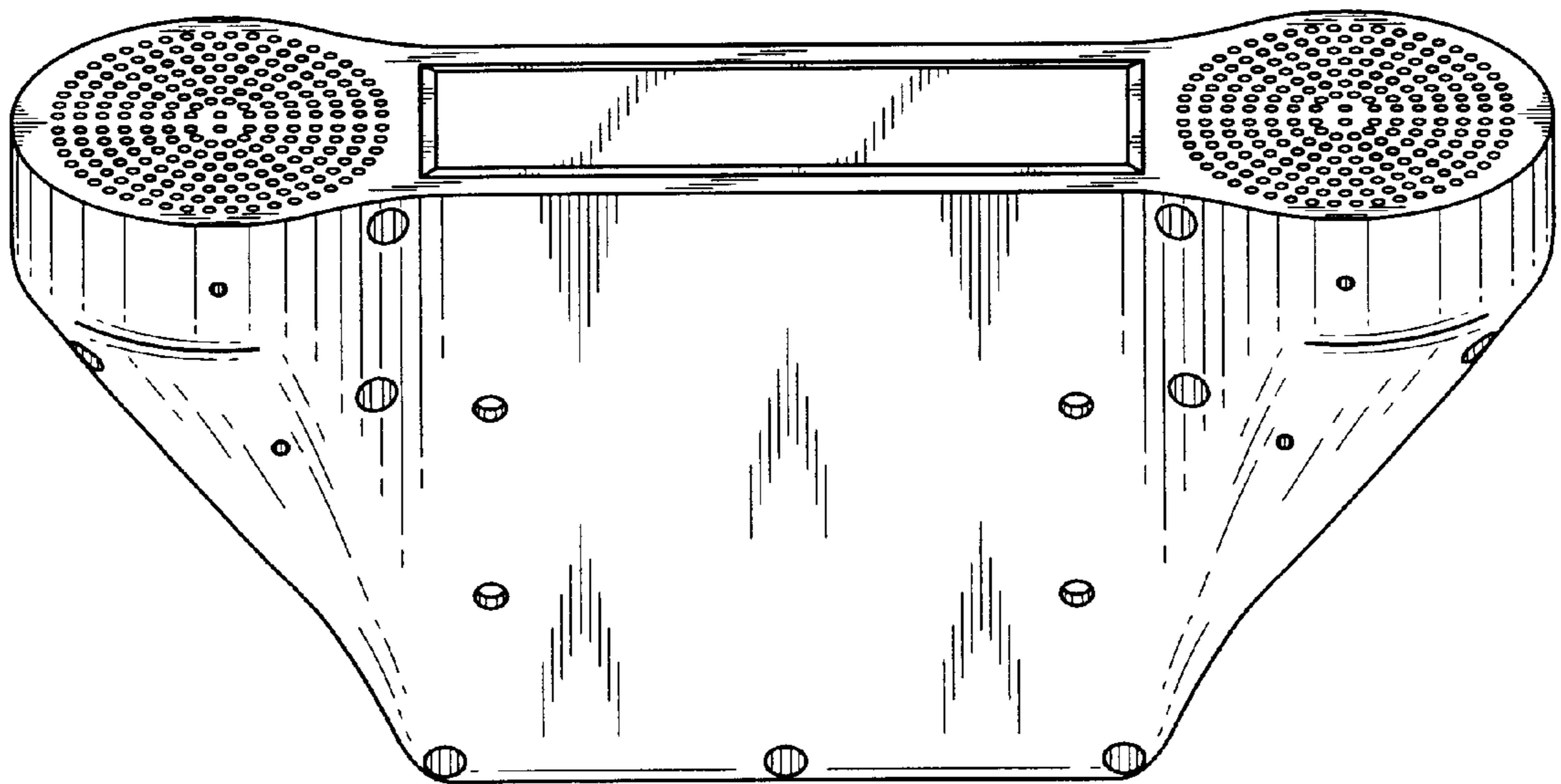

FIG. 6

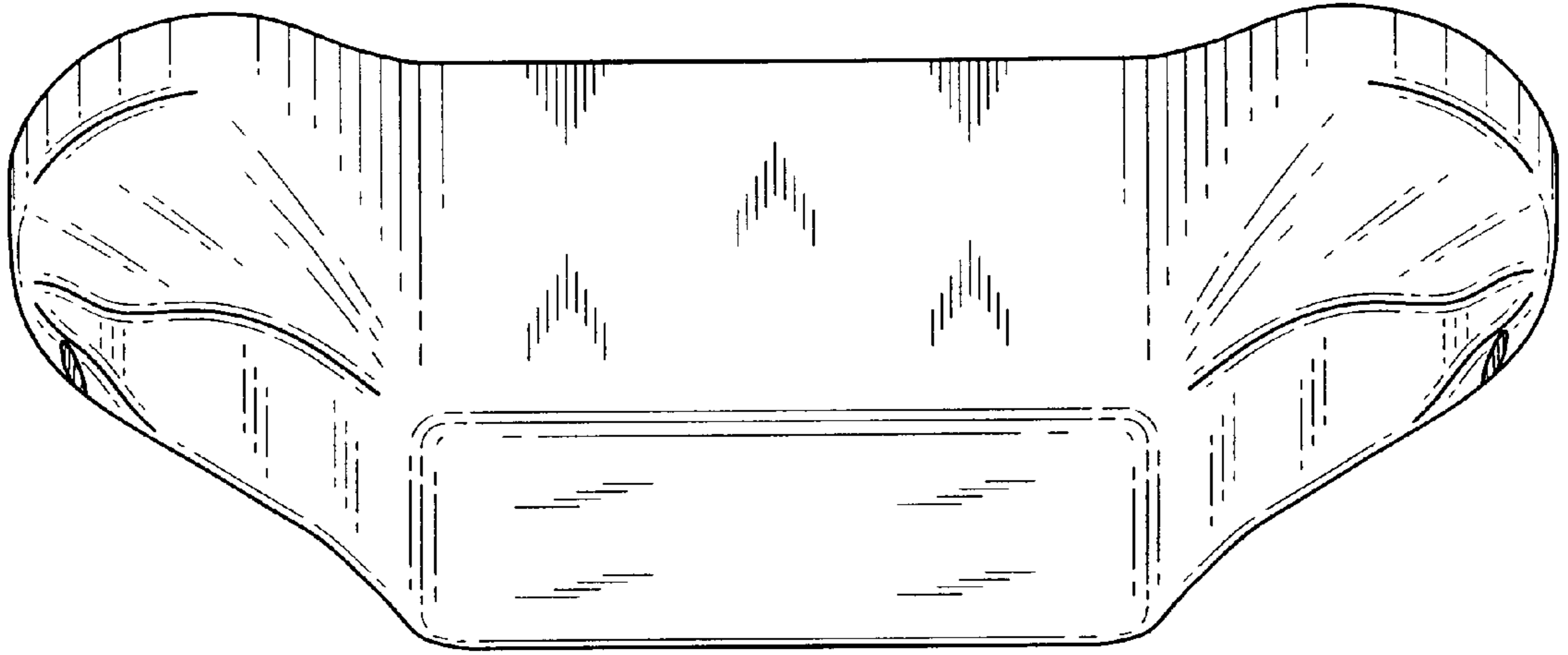

FIG. 7

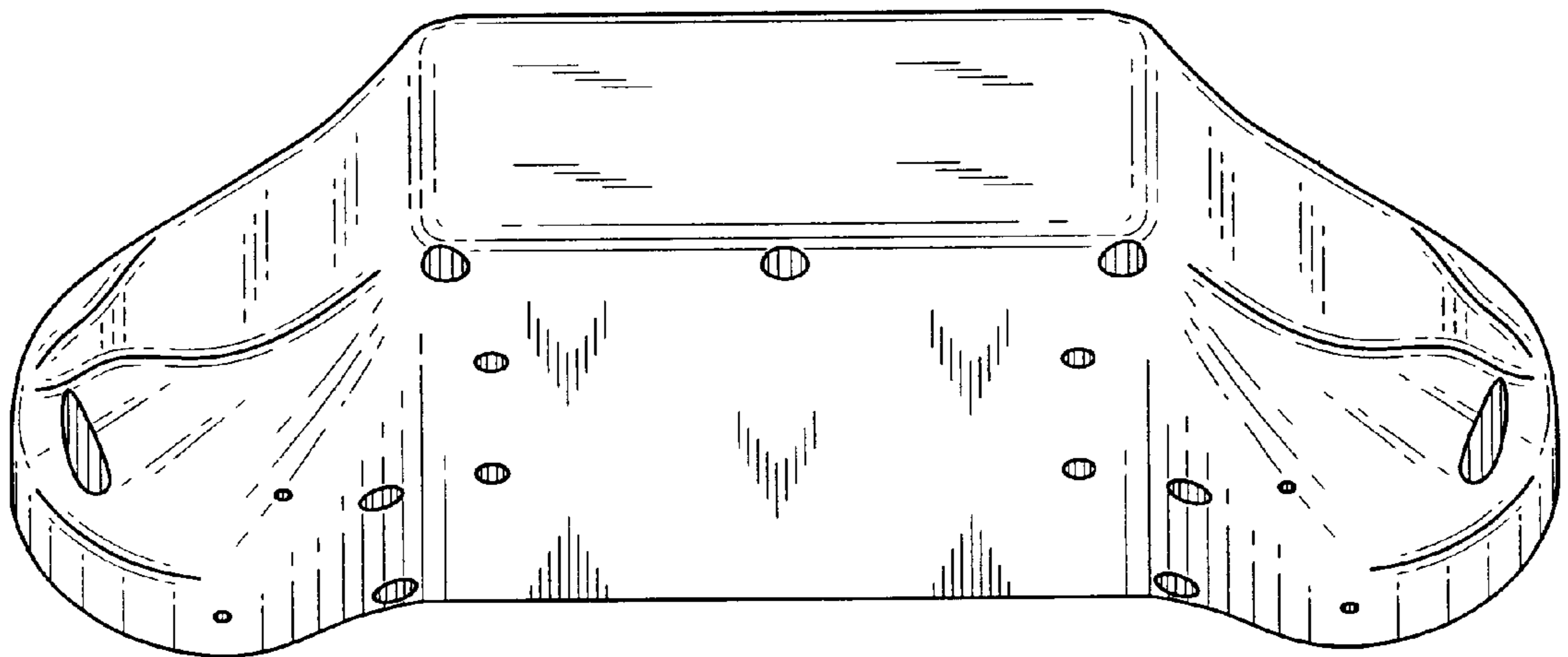

FIG. 8