



US00D474369S

(12) **United States Design Patent**  
**Benzon et al.**

(10) **Patent No.: US D474,369 S**

(45) **Date of Patent: \*\* May 13, 2003**

- (54) **MANUAL CRANK FOOD GRINDER**
- (75) Inventors: **Ian Tomas Benzon**, Copenhagen (DK);  
**Stig Lillelund**, Gentofte (DK); **Jakob Heiberg**, Charlottenlund (DK)
- (73) Assignee: **Dart Industries, Inc.**, Orlando, FL (US)
- (\*\*) Term: **14 Years**
- (21) Appl. No.: **29/152,882**
- (22) Filed: **Nov. 20, 2001**
- (51) **LOC (7) Cl. .... 31-00**
- (52) **U.S. Cl. .... D7/372; D7/384**
- (58) **Field of Search .... D7/372-374, 376-384;**  
99/286, 304, 306, 586; 241/82.1, 83, 95,  
100, 249, 277, 285.1; 366/129, 130, 197,  
204

- 4,190,208 A 2/1980 Schaeffer et al.
- 4,191,724 A 3/1980 McMillan et al.
- 4,213,569 A 7/1980 Amiot
- 4,251,476 A 2/1981 Smith
- 4,264,222 A 4/1981 Bauer
- 4,269,387 A 5/1981 Reynolds et al.
- D259,534 S 6/1981 Daenen et al.
- 4,318,879 A 3/1982 Gartner
- 4,386,740 A 6/1983 Van Deursen
- 4,390,133 A 6/1983 Wanat
- 4,588,136 A \* 5/1986 Homma ..... 241/95
- 4,602,543 A 7/1986 Homma
- D303,476 S 9/1989 Wolff et al.
- 4,884,755 A 12/1989 Hedrington
- 5,660,341 A 8/1997 Perkins et al.
- 5,680,997 A 10/1997 Hedrington
- D389,019 S 1/1998 Molo
- 5,711,491 A 1/1998 Molo
- 5,803,378 A 9/1998 Wolters
- D403,918 S \* 1/1999 Lin ..... D7/374
- D427,011 S \* 6/2000 Yip ..... D7/384
- D429,597 S \* 8/2000 Lee ..... D7/374
- D434,597 S \* 12/2000 Yip ..... D7/384

(56) **References Cited**

**U.S. PATENT DOCUMENTS**

- 568,843 A 10/1896 Engelhardt et al.
- 913,187 A 2/1909 Arnstein
- 1,114,411 A 10/1914 Stuver
- 1,271,330 A 7/1918 Lewis
- 1,669,092 A 5/1928 Kools
- 2,249,585 A 7/1941 Thomure
- 2,596,604 A 5/1952 Schaeffer
- 2,704,095 A 3/1955 Sponla
- 2,715,956 A 8/1955 Johnson et al.
- 2,789,346 A 4/1957 Algier et al.
- 3,070,883 A 1/1963 Grathwohl
- 3,209,409 A 10/1965 Grathwohl
- 3,635,270 A 1/1972 Petroske et al.
- D224,674 S 8/1972 Ashton et al.
- 3,698,460 A 10/1972 Ashton et al.
- D225,286 S 11/1972 Ashton et al.
- 3,825,049 A 7/1974 Swett et al.
- 3,907,215 A 9/1975 Mantelet
- D242,973 S 1/1977 Daenen

\* cited by examiner

*Primary Examiner*—Sandra L. Morris  
(74) *Attorney, Agent, or Firm*—Taylor J. Ross

(57) **CLAIM**

The ornamental design for a manual crank food grinder, as shown and described.

**DESCRIPTION**

FIG. 1 is a top, side and front perspective view of a manual crank food grinder showing the new design; FIG. 2 is a right side elevation view thereof; FIG. 3 is a left side elevation view thereof; FIG. 4 is a rear side elevation view thereof; FIG. 5 is a front side elevation view thereof; FIG. 6 is a top plan view thereof; and, FIG. 7 is a bottom plan view thereof.

**1 Claim, 3 Drawing Sheets**

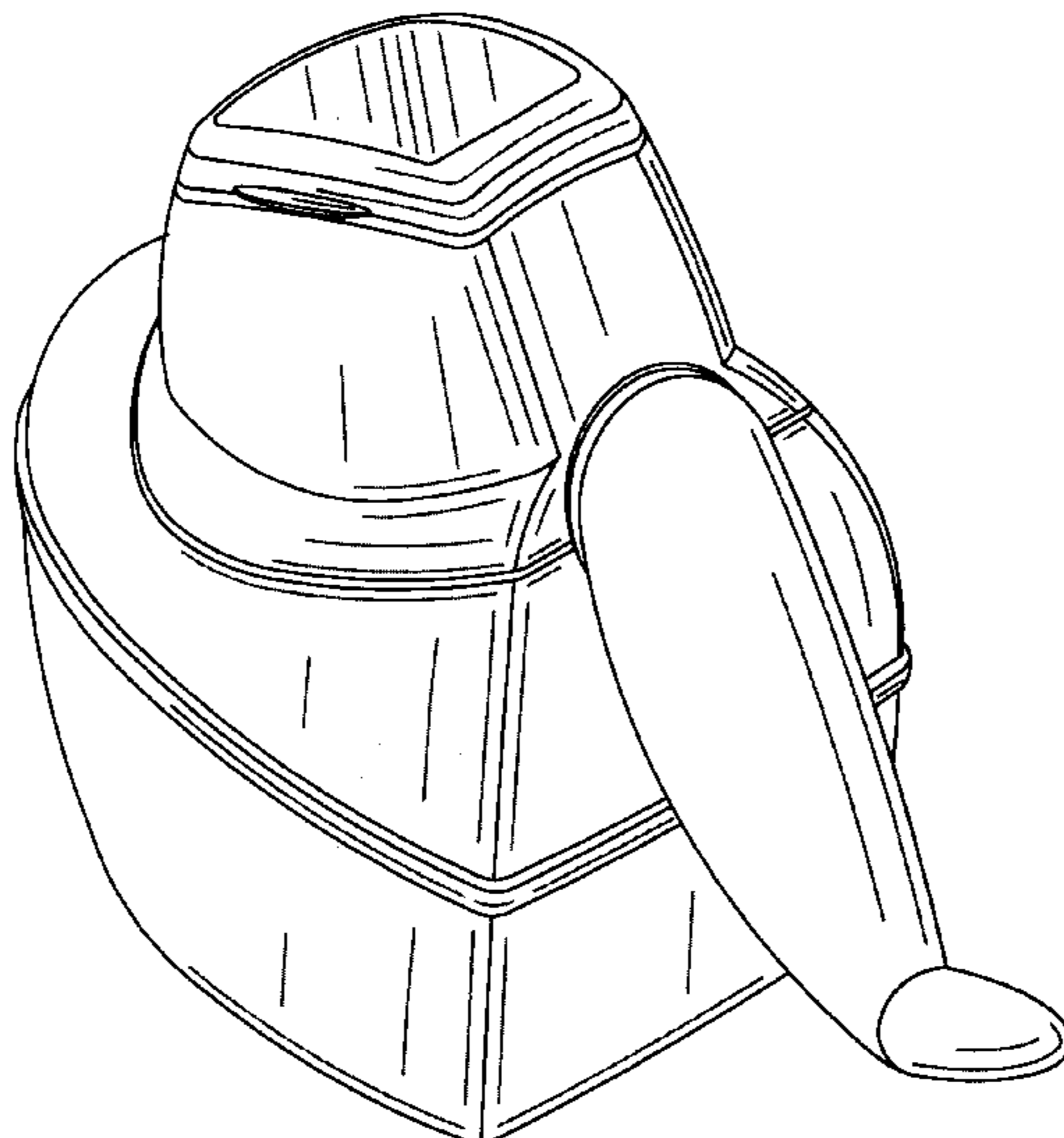

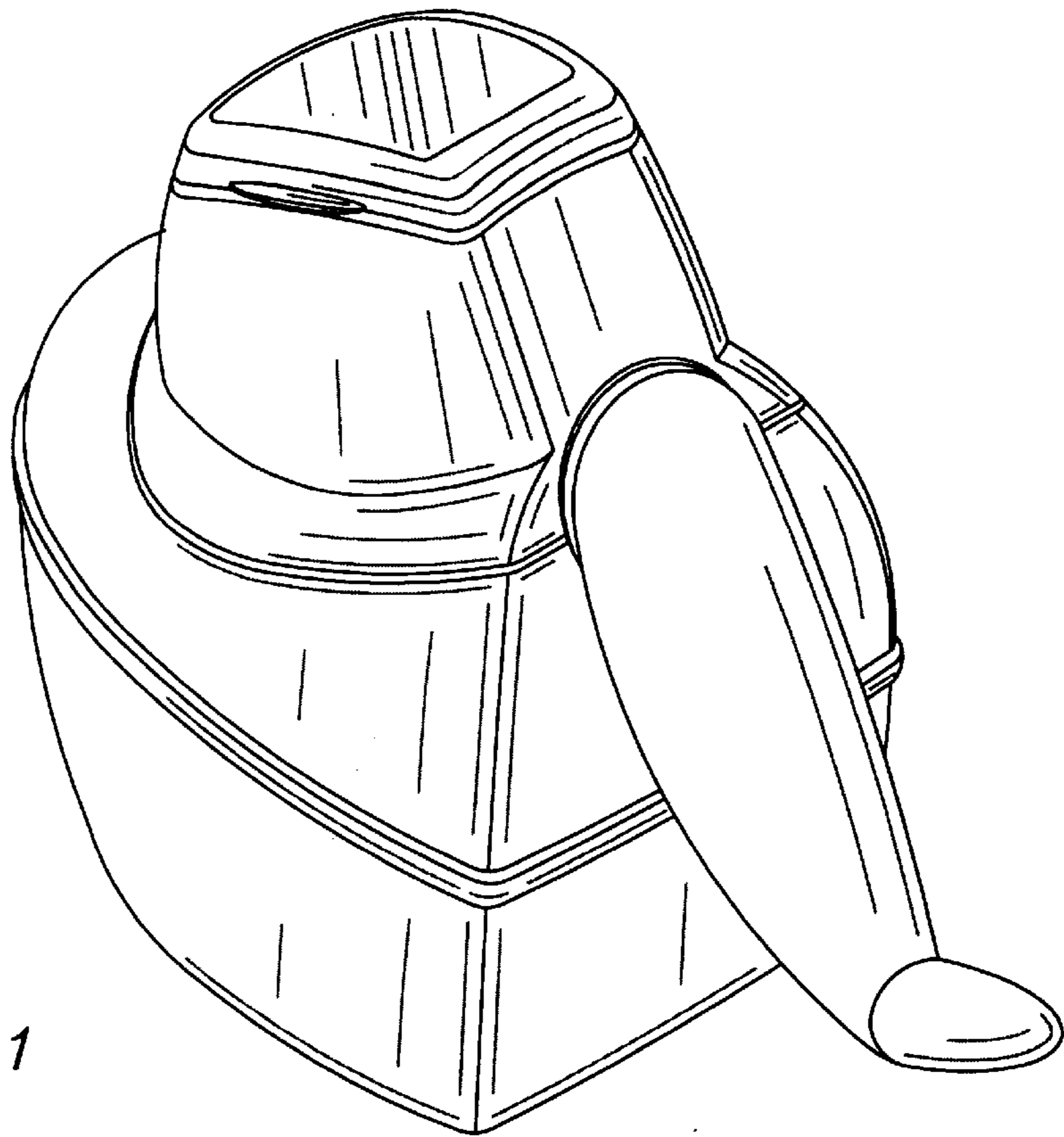

FIG. 1

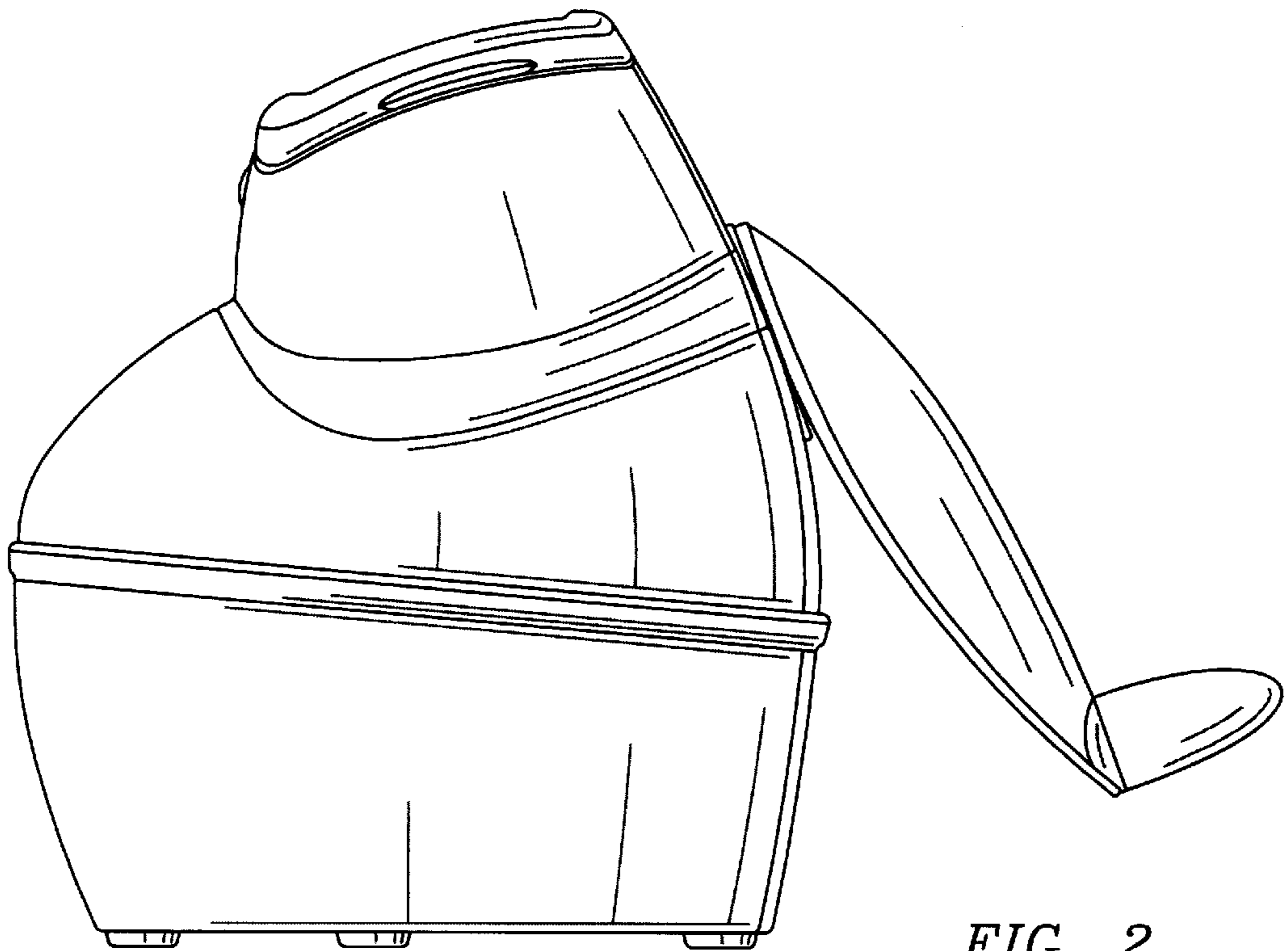

FIG. 2

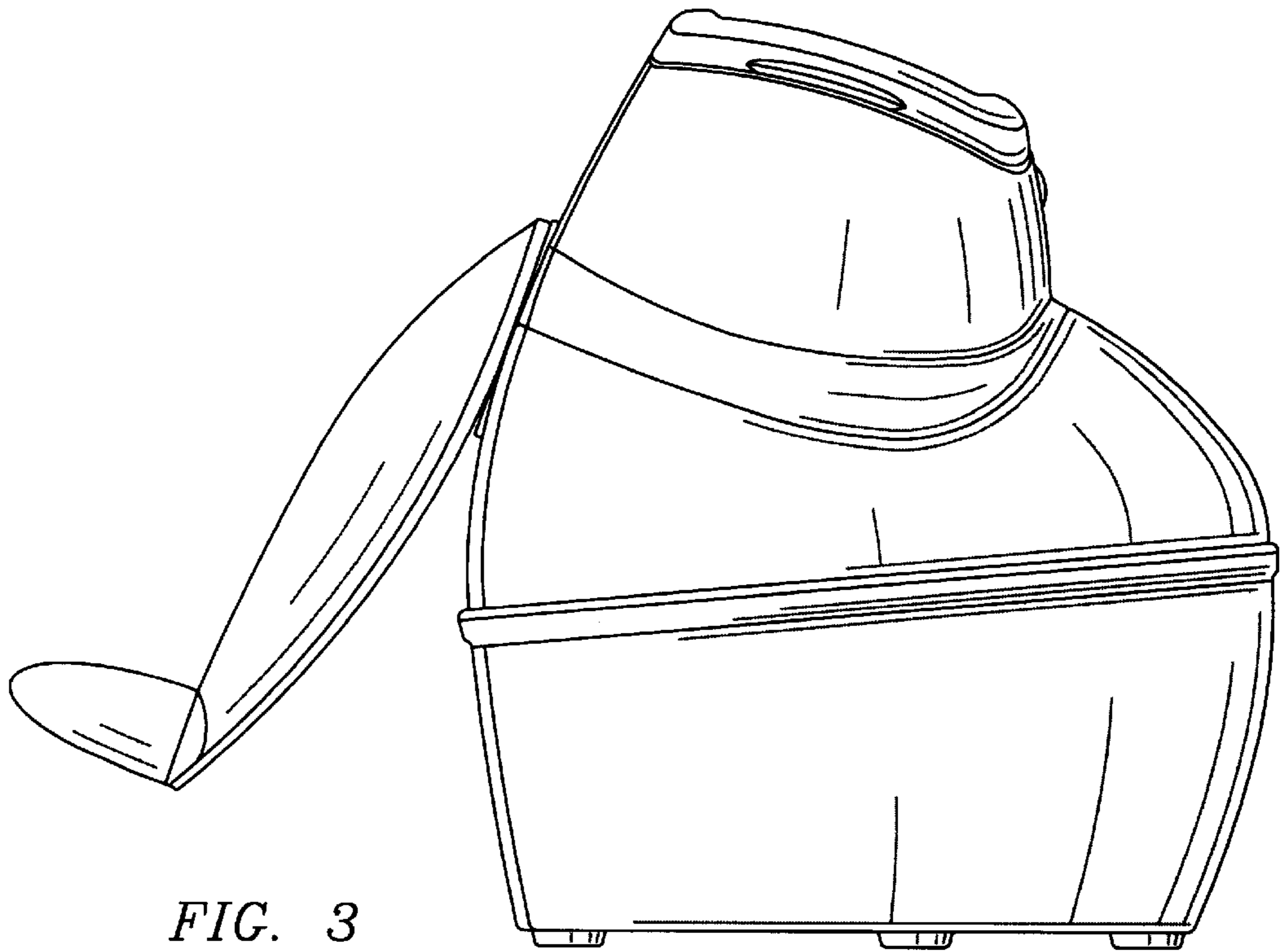

FIG. 3

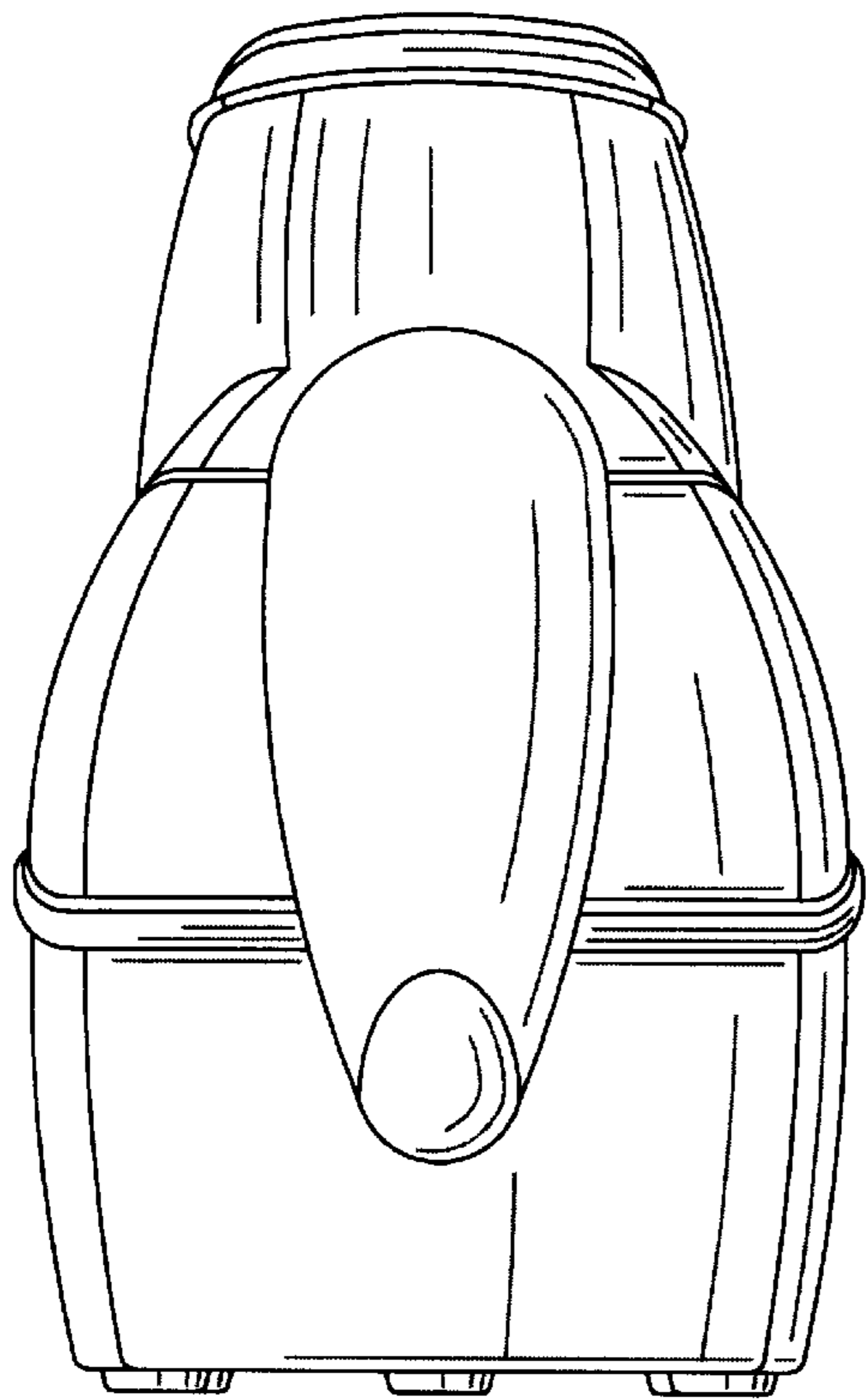

FIG. 4

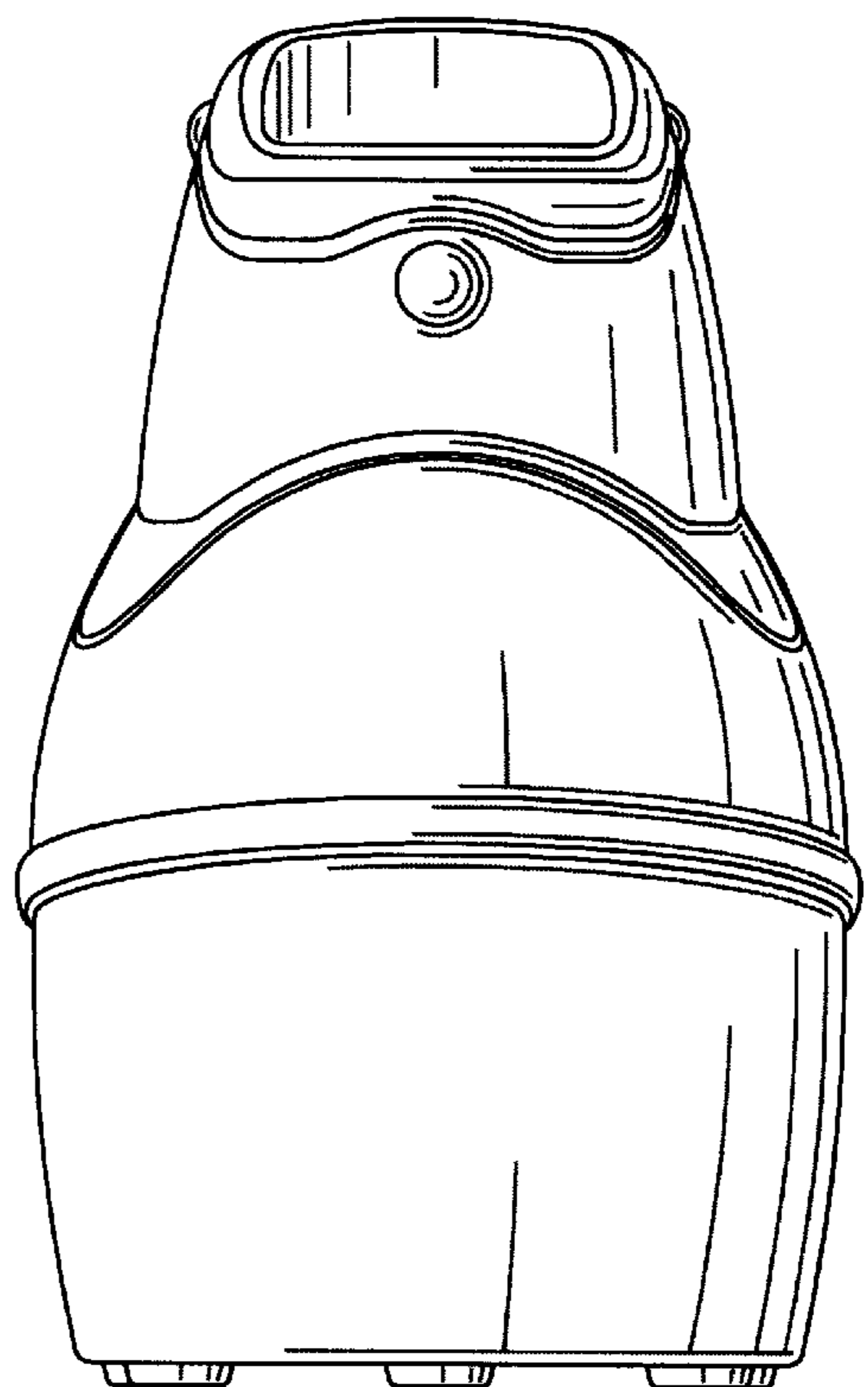

FIG. 5



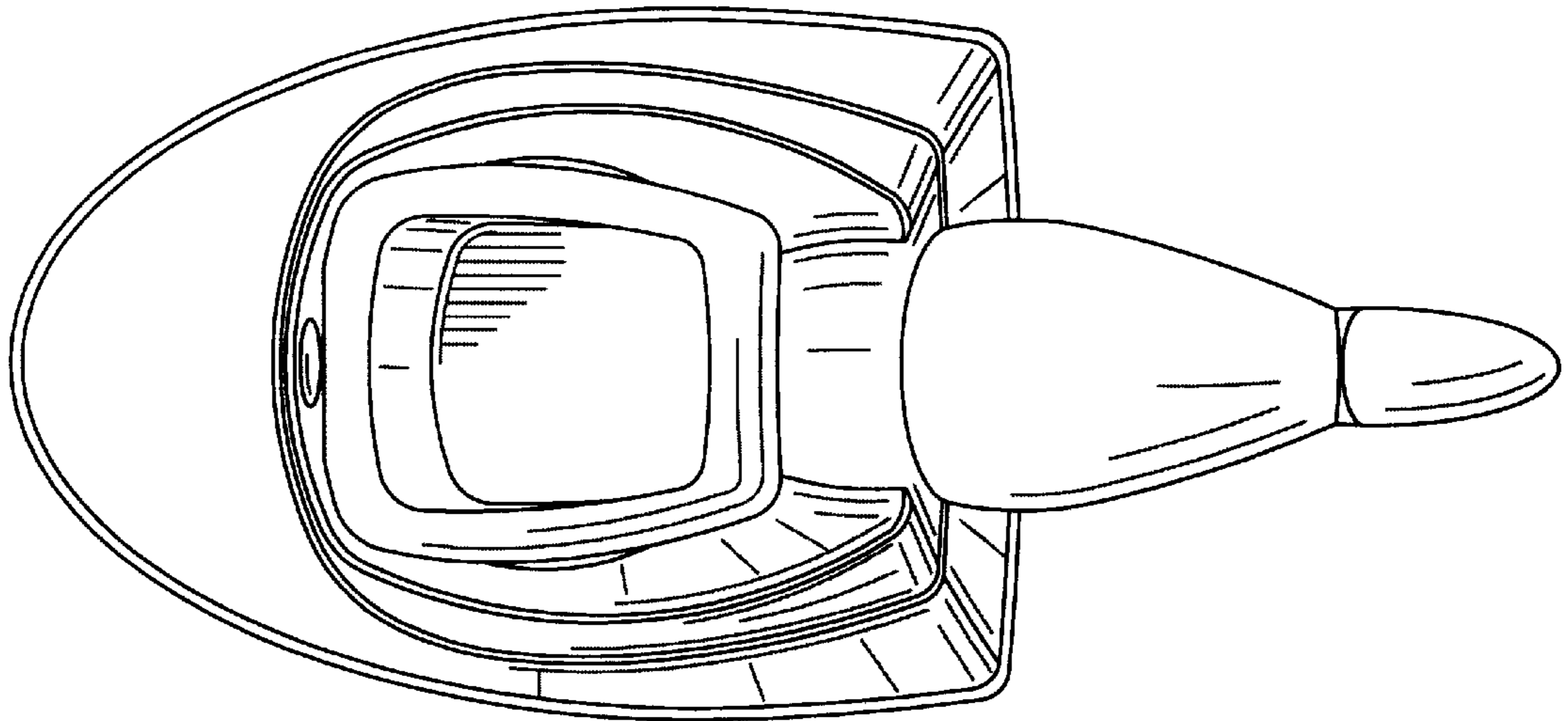

FIG. 6

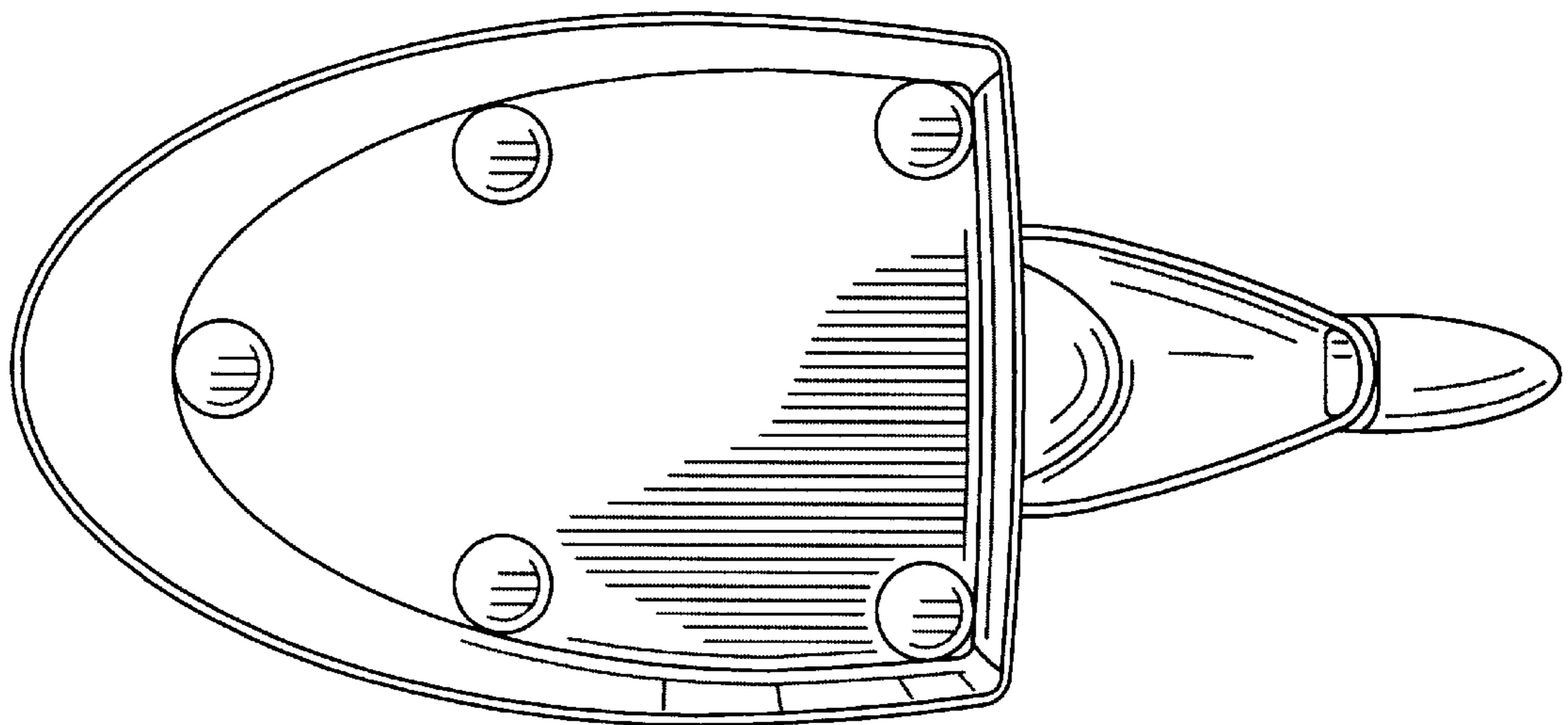

FIG. 7