



US00D474135S

(12) **United States Design Patent**
Grogan

(10) **Patent No.:** **US D474,135 S**

(45) **Date of Patent:** **** May 6, 2003**

(54) **REAR VEHICLE EXTERIOR MIRROR**

D453,721 S * 2/2002 Papke et al. D12/187

(76) Inventor: **Terence James Grogan**, 16 Powlett Street, Sunbury, Victoria, 3429 (AU)

* cited by examiner

(**) Term: **14 Years**

Primary Examiner—Melody N. Brown
(74) *Attorney, Agent, or Firm*—Wolf, Greenfield & Sacks, PC

(21) Appl. No.: **29/142,851**

(57) **CLAIM**

(22) Filed: **Jun. 4, 2001**

The ornamental design for a rear vehicle exterior mirror, as shown and described.

(30) **Foreign Application Priority Data**

Dec. 4, 2000 (AU) 3974/2000

DESCRIPTION

(51) **LOC (7) Cl.** **12-16**

(52) **U.S. Cl.** **D12/187**

(58) **Field of Search** D12/187-189;
359/838-855, 866-881

FIG. 1 is a top plan view of a rear vehicle exterior mirror showing my new design;
FIG. 2 is a bottom plan view thereof;
FIG. 3 is a left side elevational view thereof;
FIG. 4 is a right side elevational view thereof;
FIG. 5 is a top side elevational view thereof;
FIG. 6 is a bottom side elevational view thereof;
FIG. 7 is a top perspective view thereof; and,
FIG. 8 is a bottom perspective view thereof.

(56) **References Cited**

U.S. PATENT DOCUMENTS

- D335,273 S * 5/1993 Fairweather D12/187
- D365,317 S * 12/1995 Hellmund D12/187
- D367,457 S * 2/1996 Fuleihan D12/187
- D375,070 S * 10/1996 Yeabower D12/187
- D375,712 S * 11/1996 Bialowas et al. D12/187
- D375,926 S * 11/1996 Snyder D12/187

The broken lines are intended to merely show the base portion of the design and is not intended to be part of the claim.

1 Claim, 2 Drawing Sheets

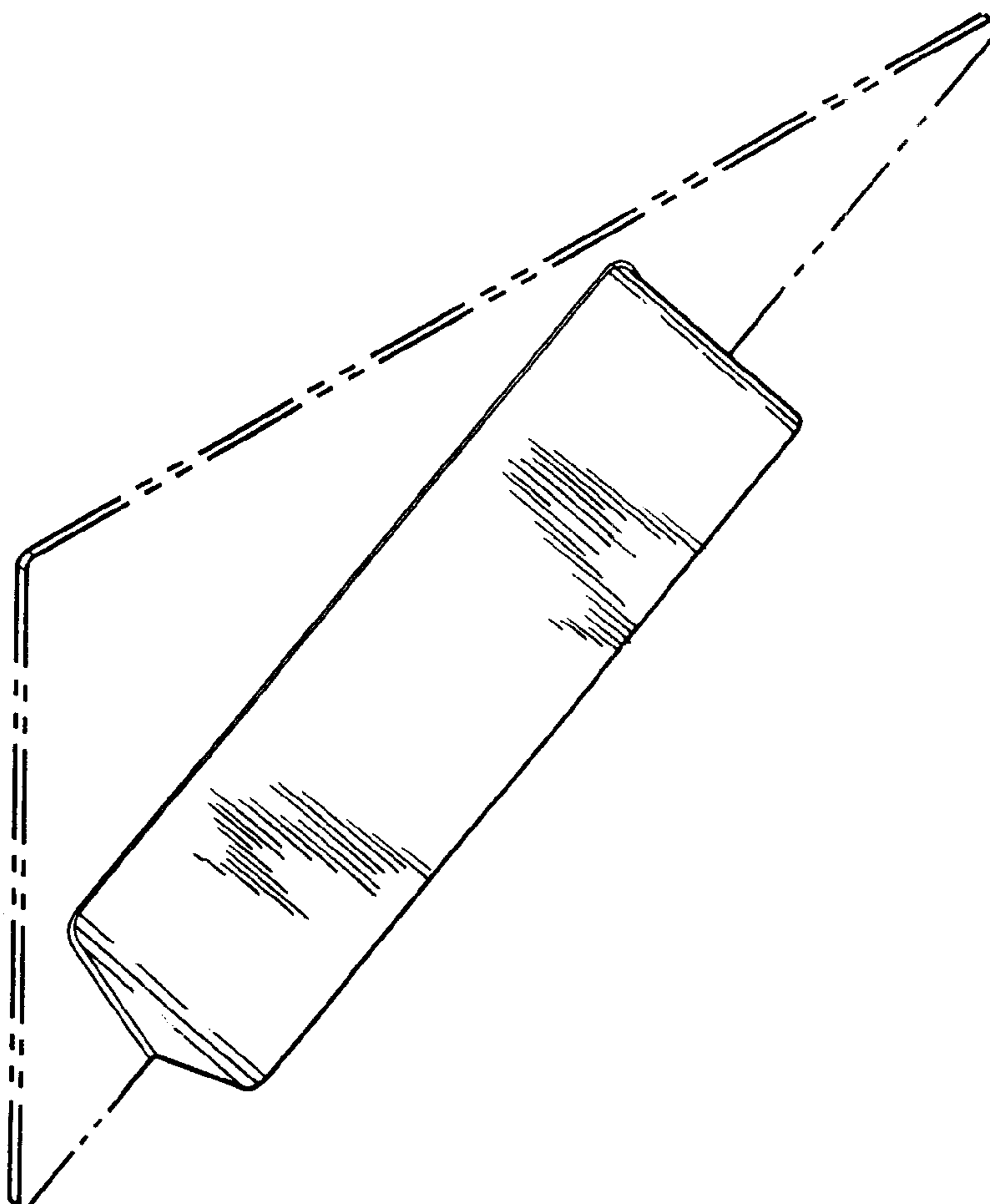

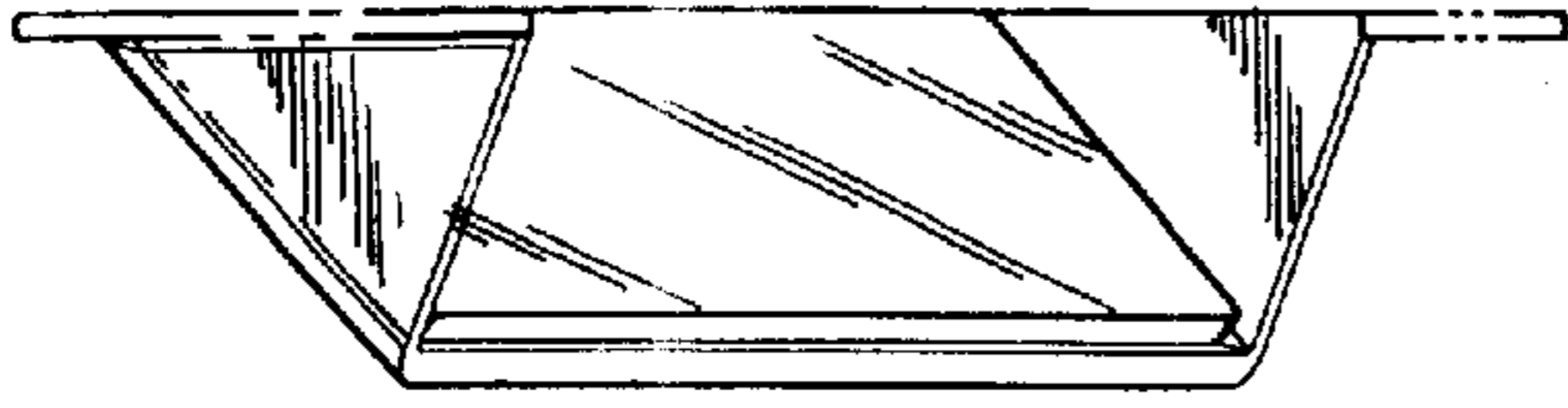

FIG 4

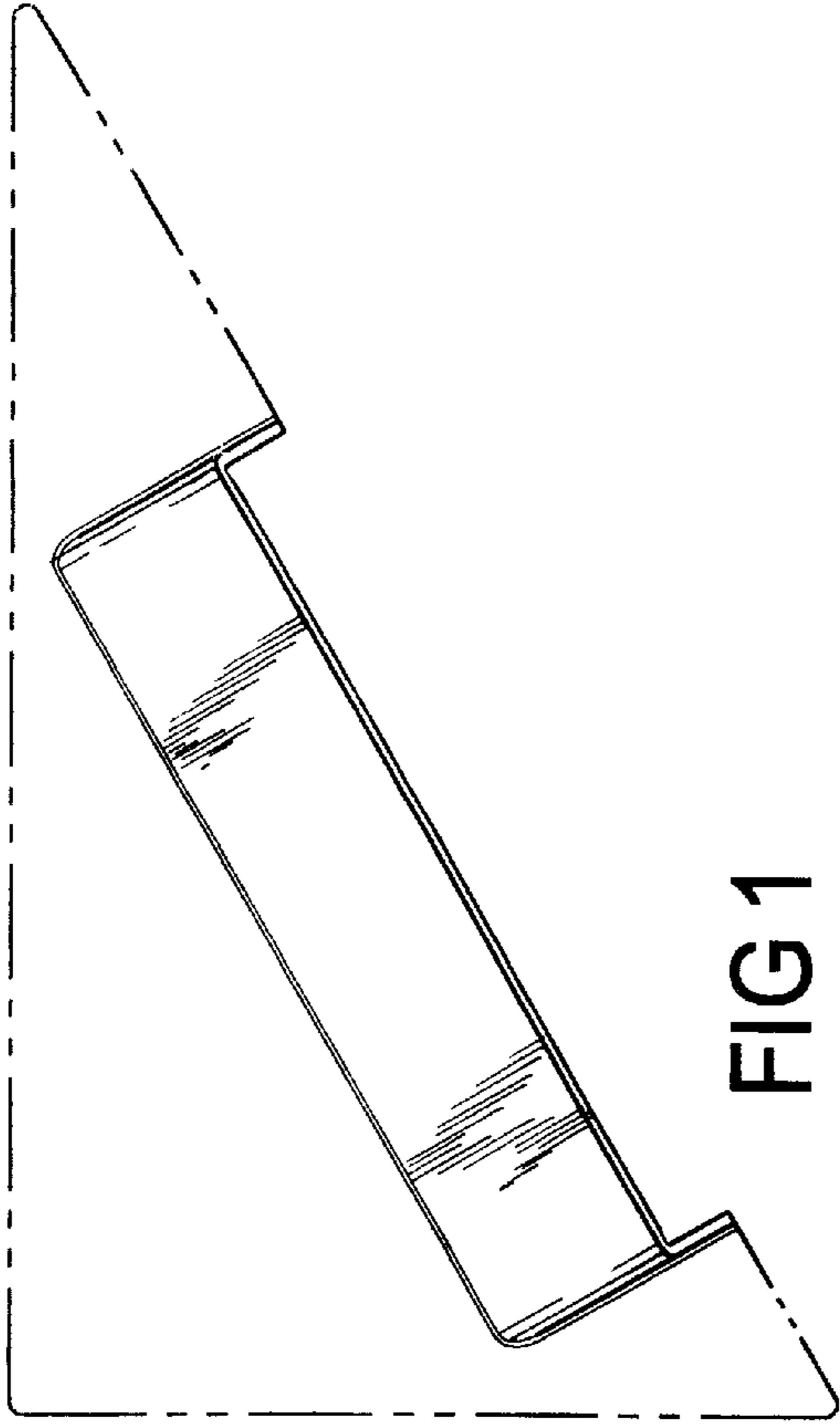

FIG 1

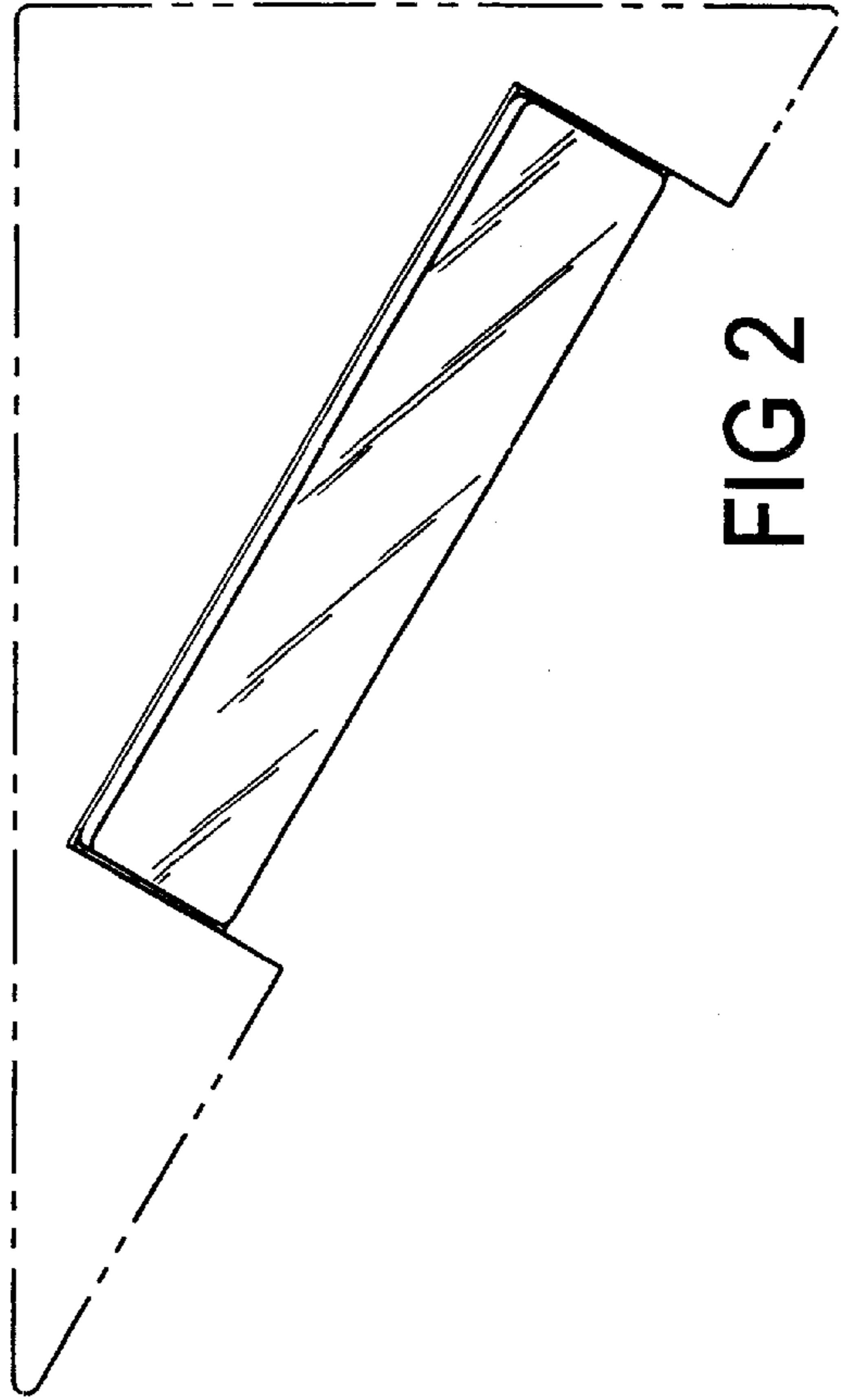

FIG 2

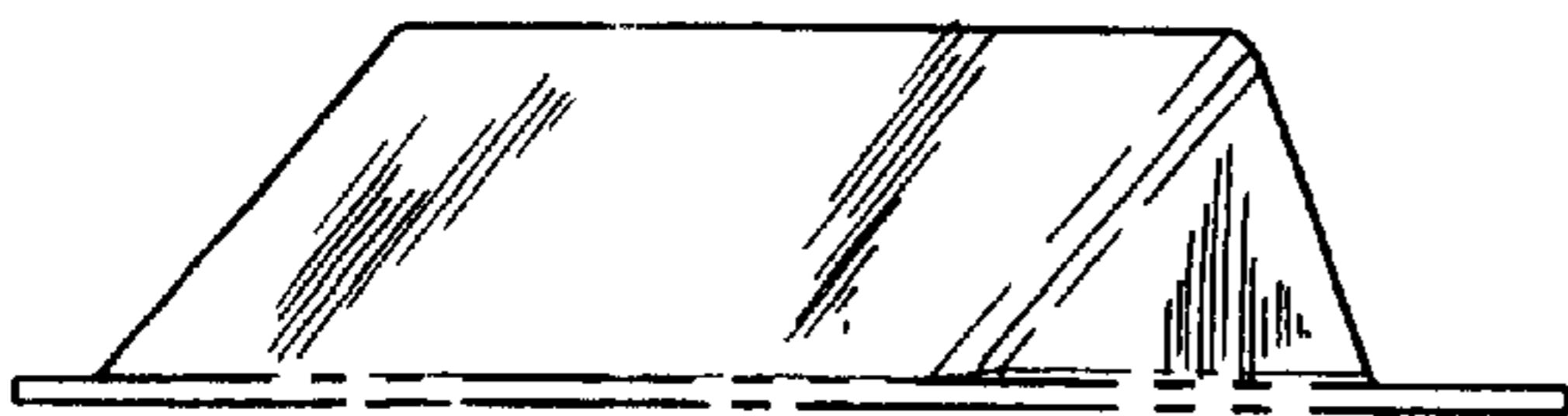

FIG 3

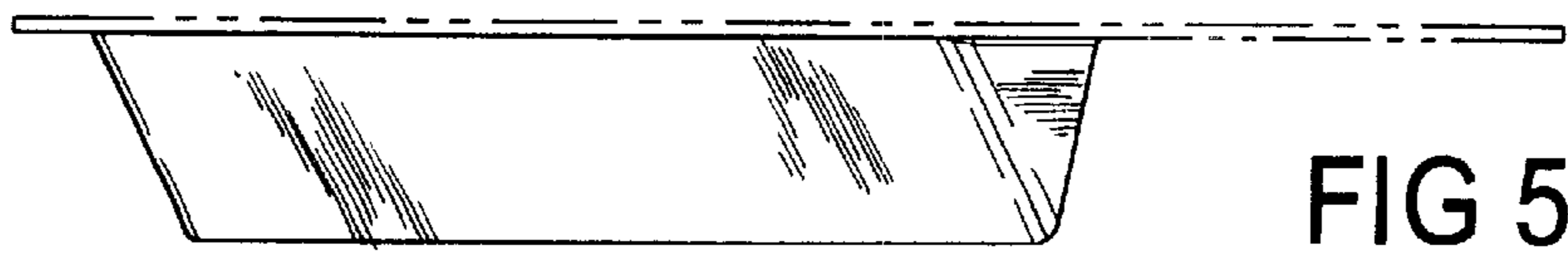

FIG 5

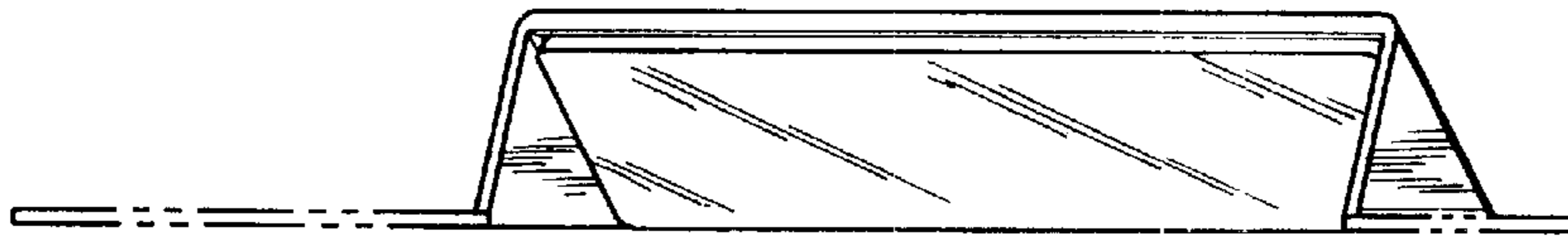

FIG 6

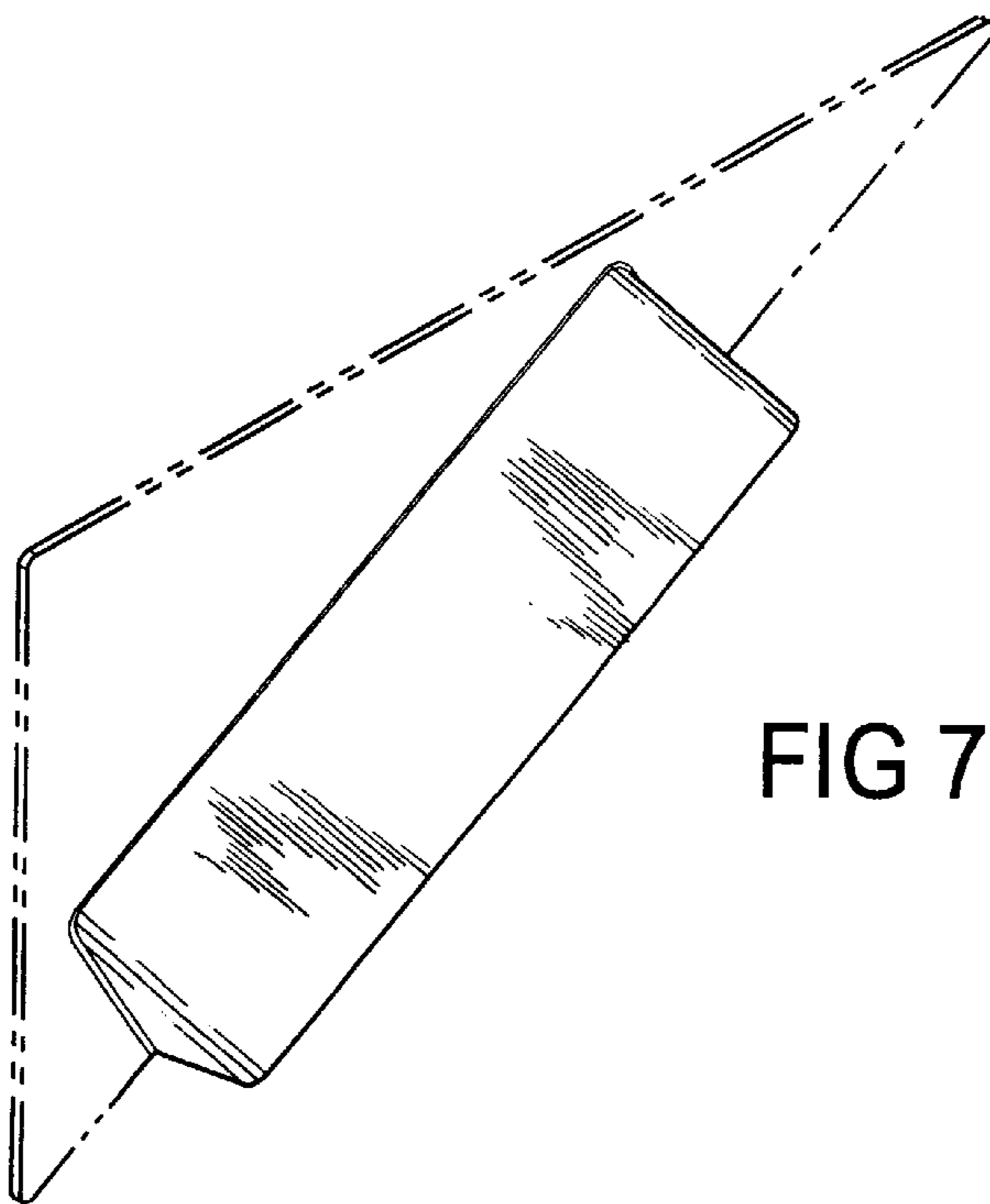

FIG 7

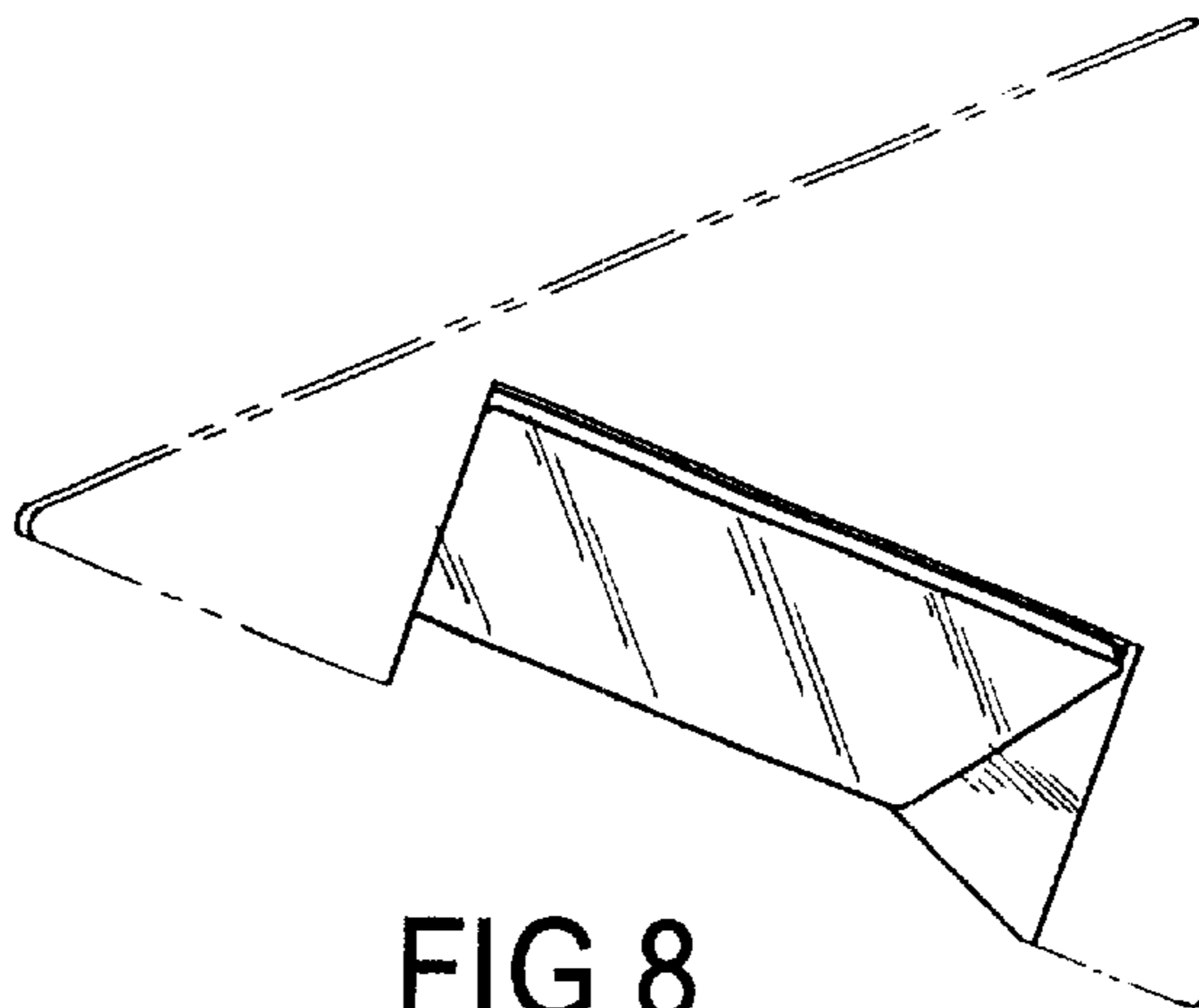

FIG 8