



US00D473885S

(12) **United States Design Patent**
Horikiri et al.

(10) **Patent No.:** **US D473,885 S**

(45) **Date of Patent:** **** Apr. 29, 2003**

(54) **ELECTRONIC STILL CAMERA**

(75) Inventors: **Kazuhisa Horikiri**, Tokyo (JP);
Hiroyuki Sakai, Tokyo (JP)

(73) Assignee: **Fuji Photo Film Co., Ltd.**, Kanagawa
(JP)

(**) Term: **14 Years**

(21) Appl. No.: **29/163,600**
(22) Filed: **Jul. 10, 2002**

(30) **Foreign Application Priority Data**

Feb. 12, 2002 (JP) 2002-003344

(51) **LOC (7) Cl.** **16-01**
(52) **U.S. Cl.** **D16/202; D16/218**
(58) **Field of Search** **D16/200-205,**
D16/208, 218; 348/373-376; 358/909.1;
396/535-541

(56) **References Cited**

U.S. PATENT DOCUMENTS

D408,044 S	*	4/1999	Tanaka et al.	D16/202
D418,151 S	*	12/1999	Sumita	D16/202
D436,976 S	*	1/2001	Tanaka	D16/202
D450,071 S	*	11/2001	Funato	D16/202
D457,902 S	*	5/2002	Porsche et al.	D16/202
2001/0017664 A1	*	8/2001	Misawa	348/373

OTHER PUBLICATIONS

Fuji Digital camera catalog, "Fine Pix 2700" Oct. 1999.*
Better Homes and Gardens, Feb. 2000 vol. 78, Issue 2
(Polaroids's Photo Max).*

* cited by examiner

Primary Examiner—Adir Aronovich
(74) *Attorney, Agent, or Firm*—Young & Thompson

(57) **CLAIM**

The ornamental design for an electronic still camera, as shown and described.

DESCRIPTION

FIG. 1 is a front, top side perspective view of an electronic still camera showing our new design;
FIG. 2 is a front elevational view thereof;
FIG. 3 is a rear elevational view thereof;
FIG. 4 is a top plan view thereof;
FIG. 5 is a bottom plan view thereof;
FIG. 6 is a side elevational view thereof from the left of FIG. 2;
FIG. 7 is a side elevational view thereof from the right of FIG. 2; and,
FIG. 8 is a view similar to FIG. 1, but with the parts in a different position.

1 Claim, 4 Drawing Sheets

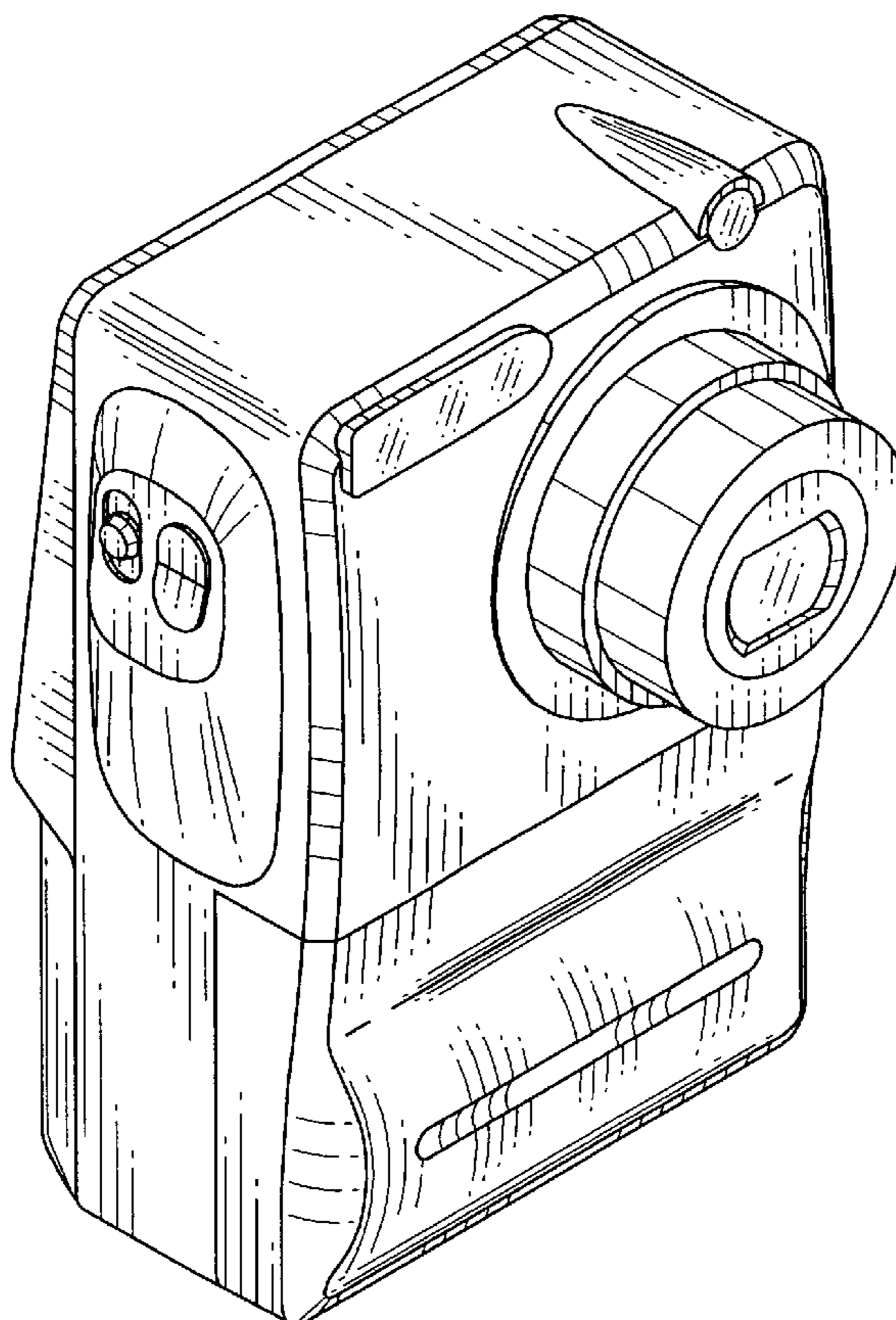

FIG. 1

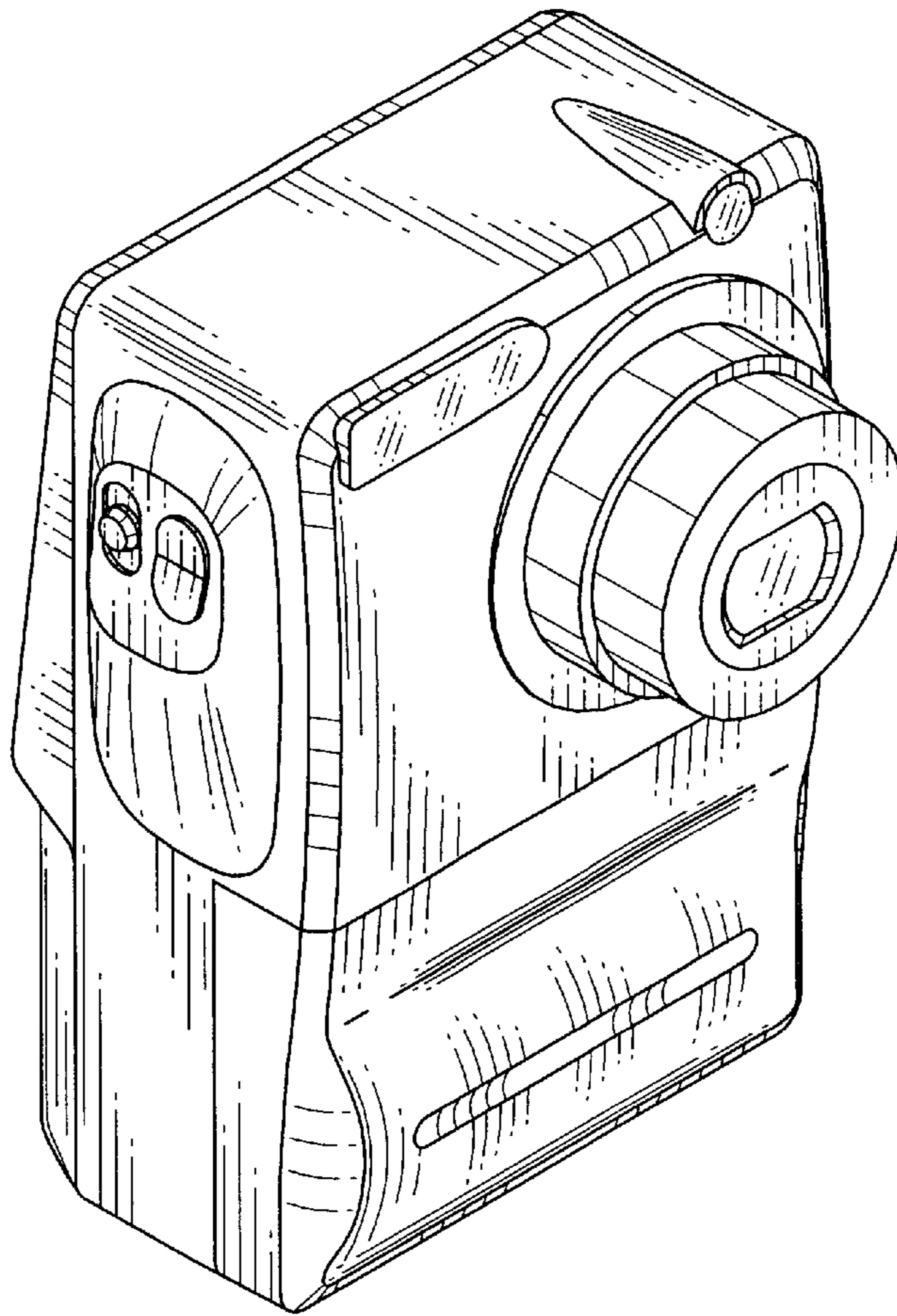

FIG. 2

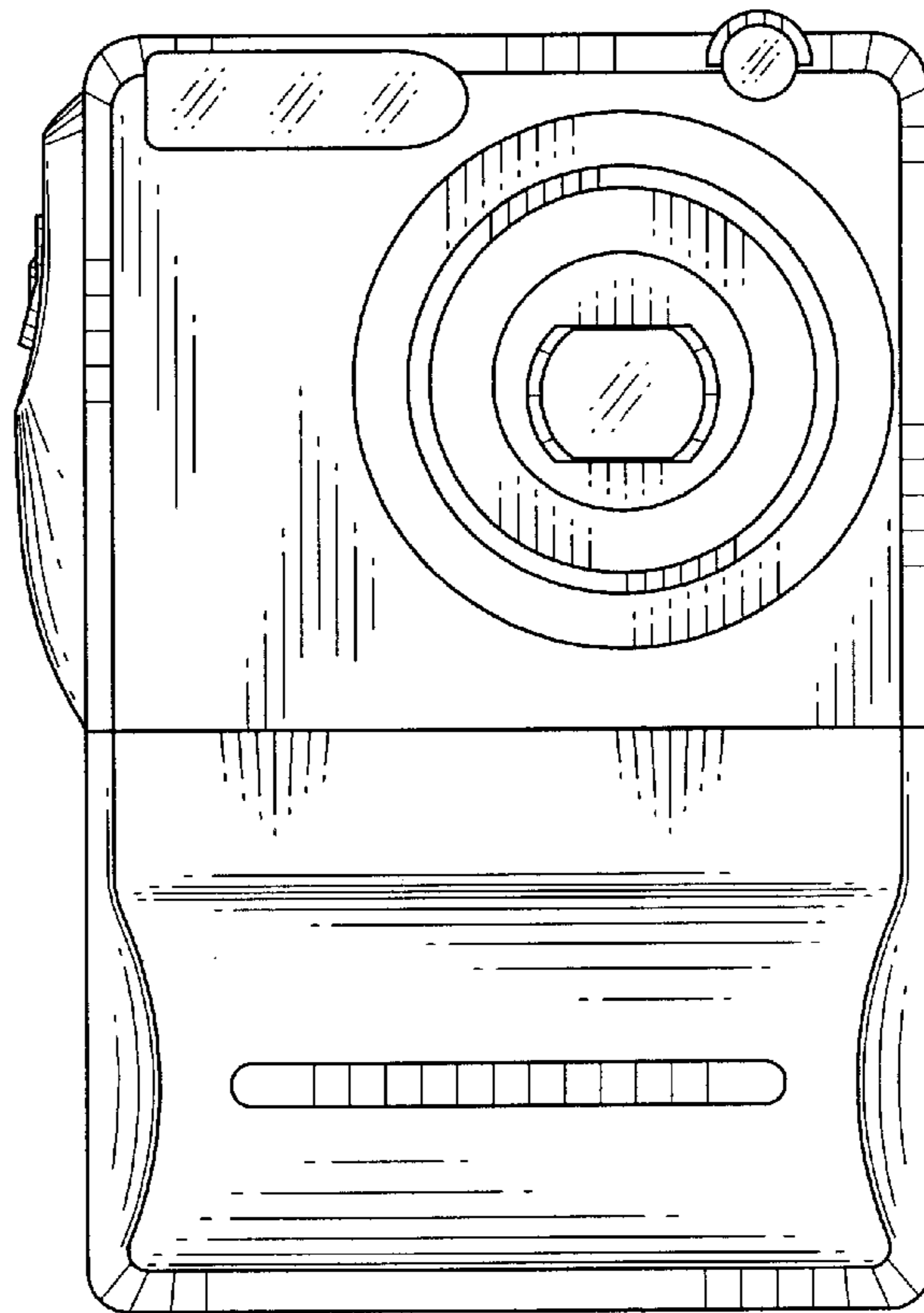

FIG. 3

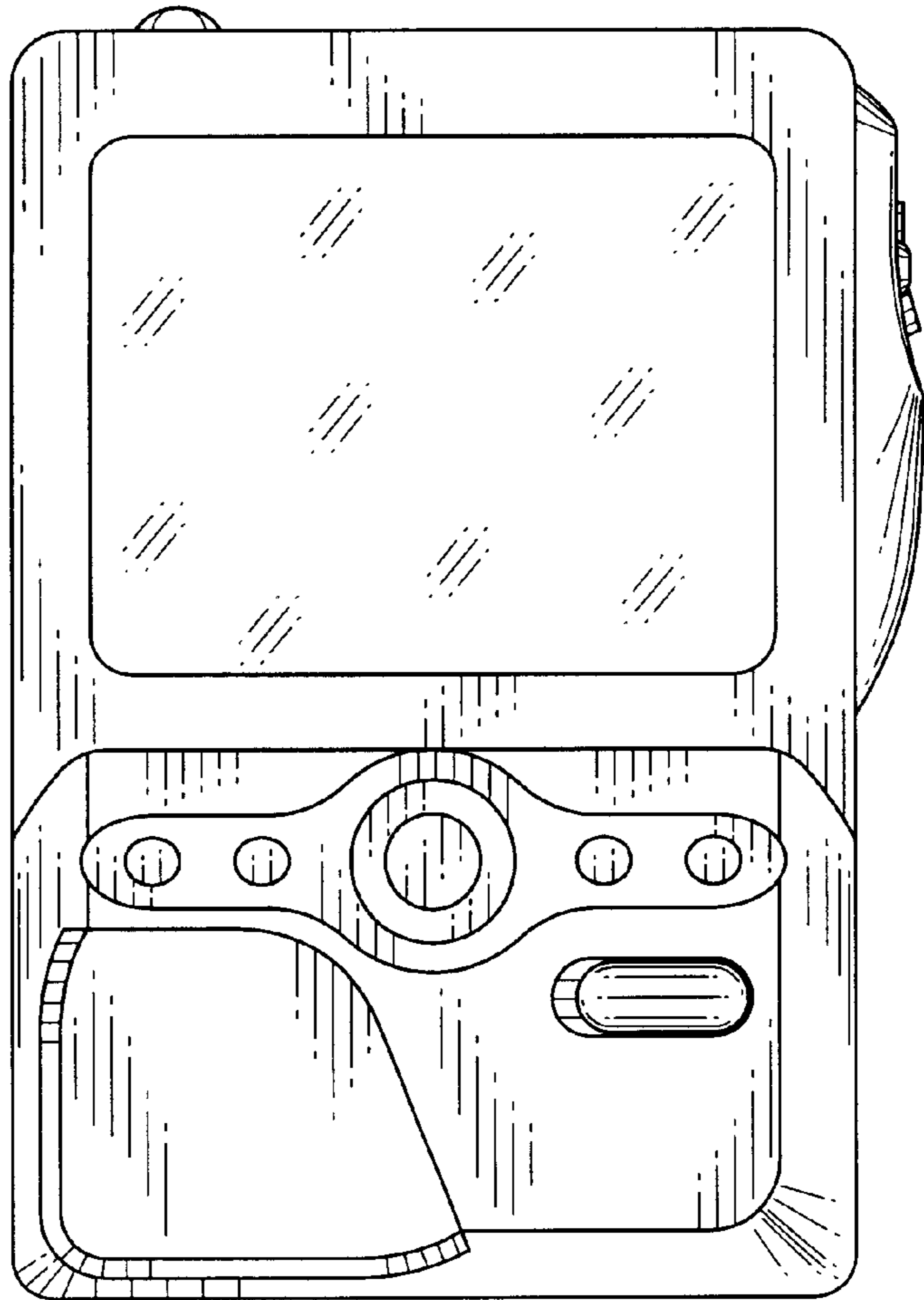

FIG. 4

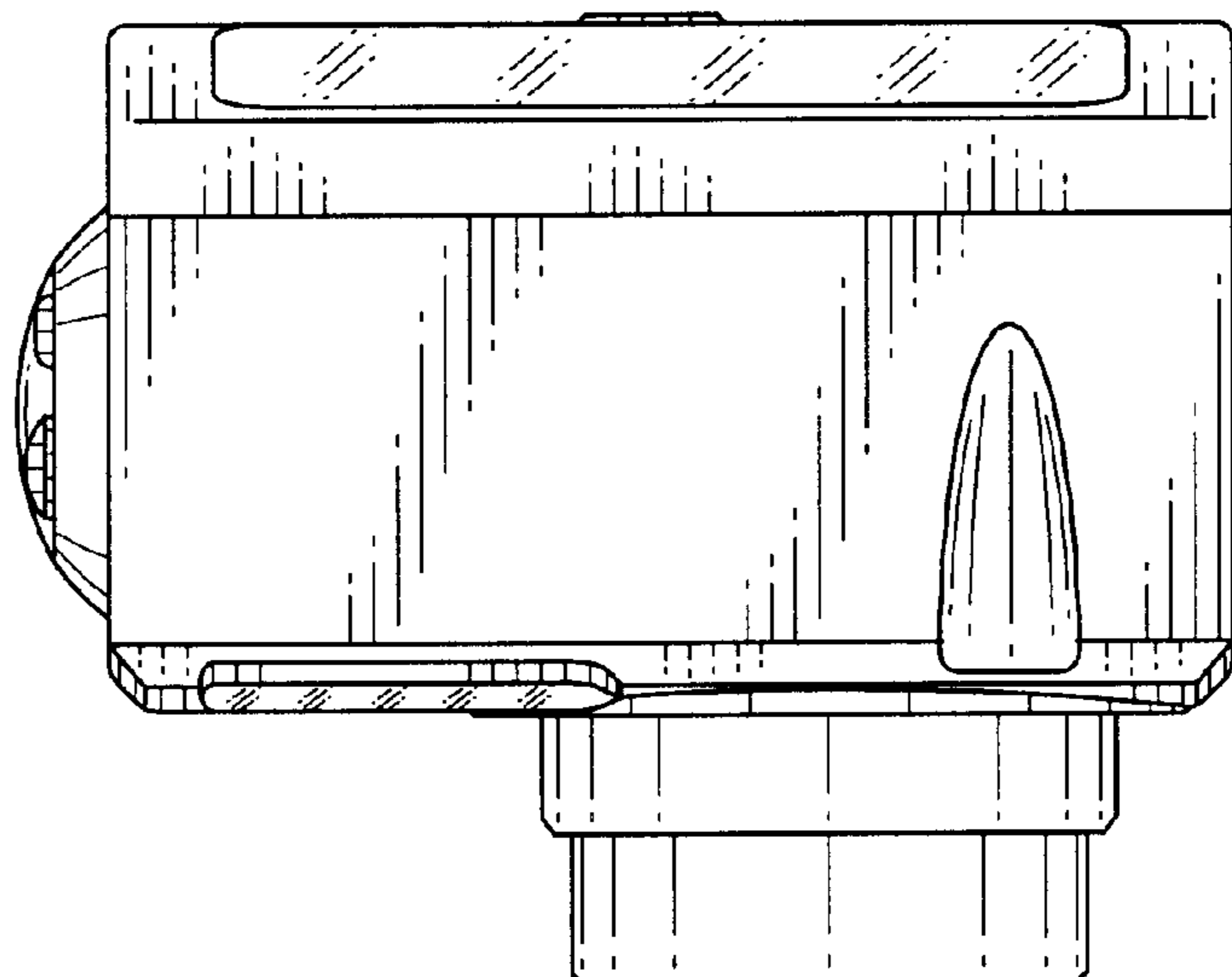

FIG. 5

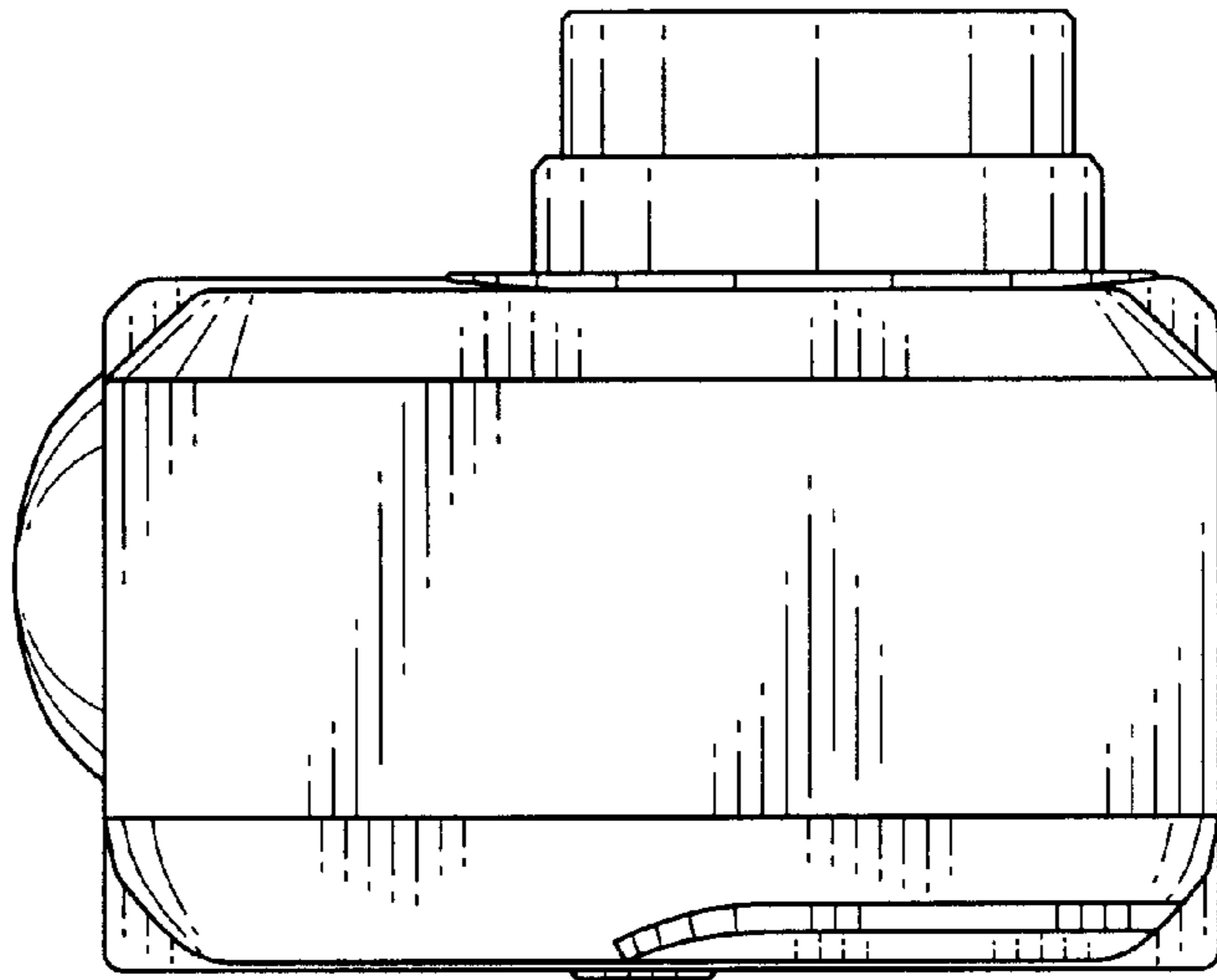

FIG. 6

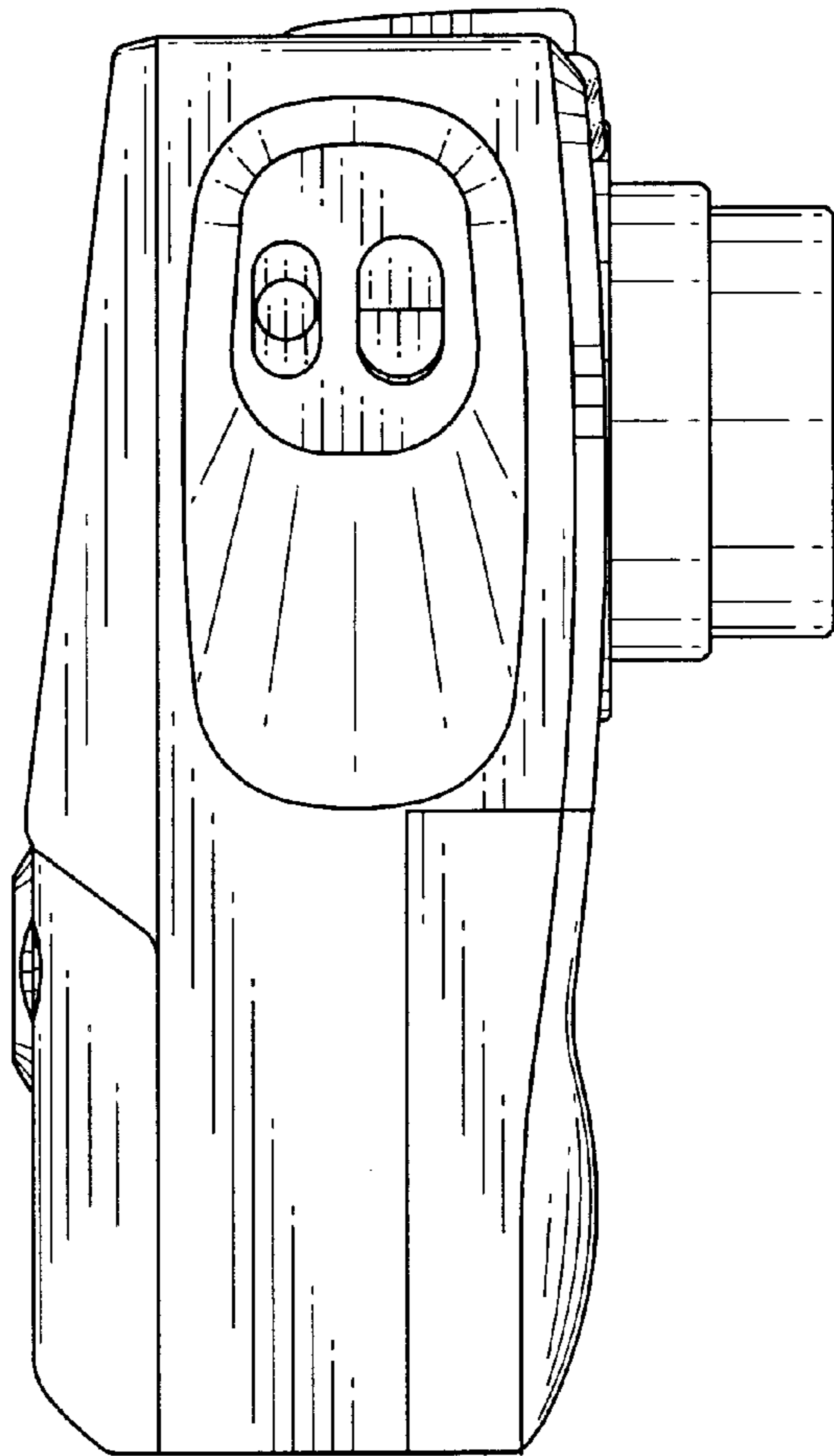

FIG. 7

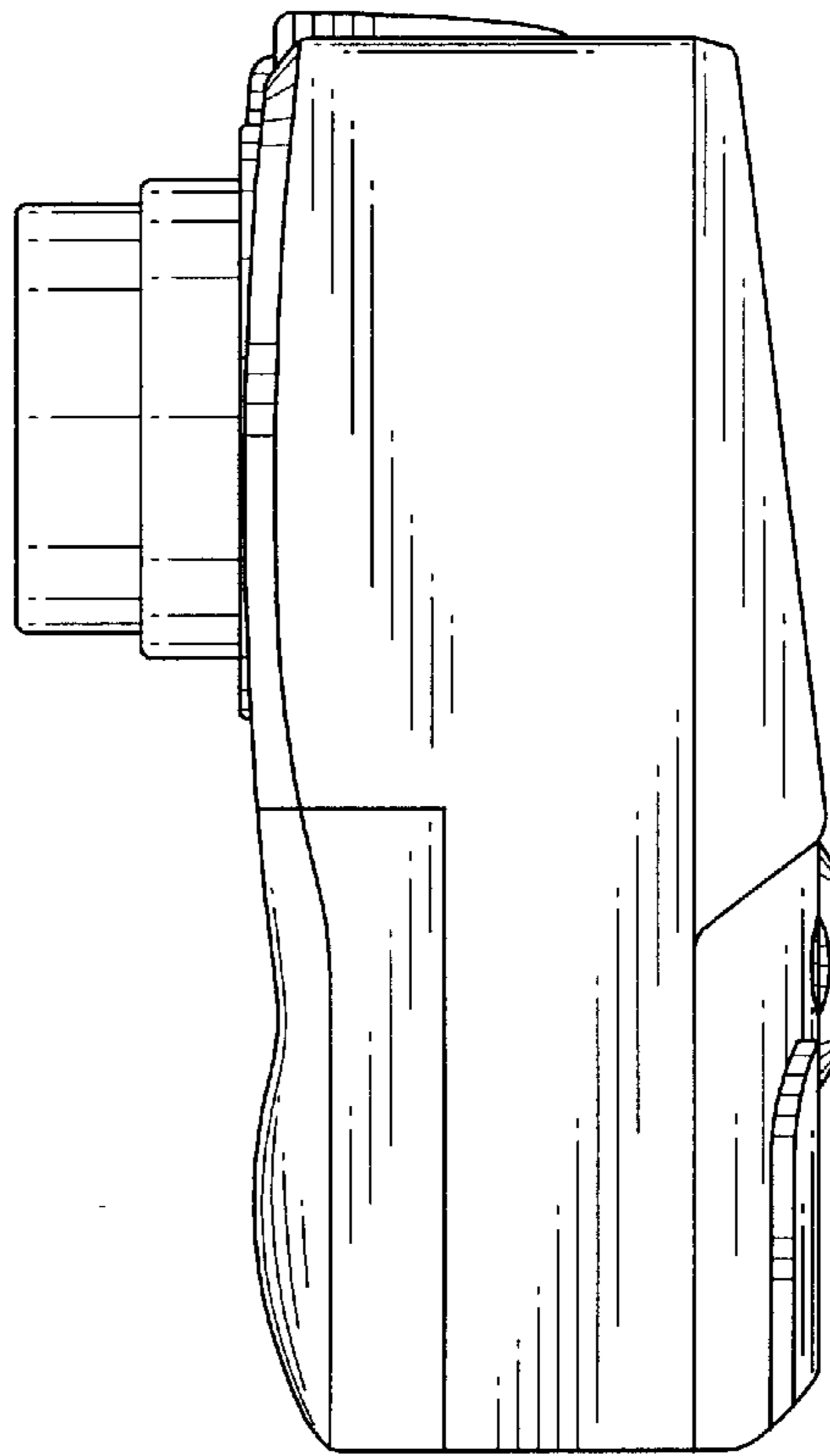

FIG. 8

