



US00D473567S

(12) **United States Design Patent**
Campbell

(10) **Patent No.:** **US D473,567 S**

(45) **Date of Patent:** **** Apr. 22, 2003**

(54) **TROLLING MOTOR PROPELLER**

(76) **Inventor:** **James Stewart Campbell, 3705**
Sapona Trail, Pfafftown, NC (US)
27040

(**) **Term:** **14 Years**

(21) **Appl. No.:** **29/160,860**

(22) **Filed:** **May 20, 2002**

(51) **LOC (7) Cl.** **15-01**

(52) **U.S. Cl.** **D15/5**

(58) **Field of Search** **D15/1-5; 416/223 R,**
416/158, 157 R; 454/329; 440/50, 49

(56) **References Cited**

U.S. PATENT DOCUMENTS

D335,420 S	*	5/1993	Moore	D15/5
5,773,315 A	*	6/1998	Jarvis	440/49
581,131 A	*	12/1998	Bergeron	440/50
D428,616 S	*	7/2000	Iekura	D15/4
D452,205 S	*	12/2001	Eisenbraun	D12/162

6,332,818 B1	*	12/2001	Duncan et al.	440/50 X
6,340,290 B1	*	1/2002	Schott et al.	416/157 R
D463,448 S	*	9/2002	Osumi et al.	D15/4

* cited by examiner

Primary Examiner—Melody N. Brown

(57) **CLAIM**

The ornamental design for a trolling motor propeller, as shown and described.

DESCRIPTION

FIG. 1 is a front elevational view of a trolling motor propeller;
FIG. 2 is a rear elevational view thereof;
FIG. 3 is front perspective view thereof;
FIG. 4 is a rear perspective view thereof;
FIG. 5 is side elevational view thereof;
FIG. 6 is a side elevational view of the opposite side thereof;
FIG. 7 is top view thereof; and,
FIG. 8 is a bottom view thereof.

1 Claim, 7 Drawing Sheets

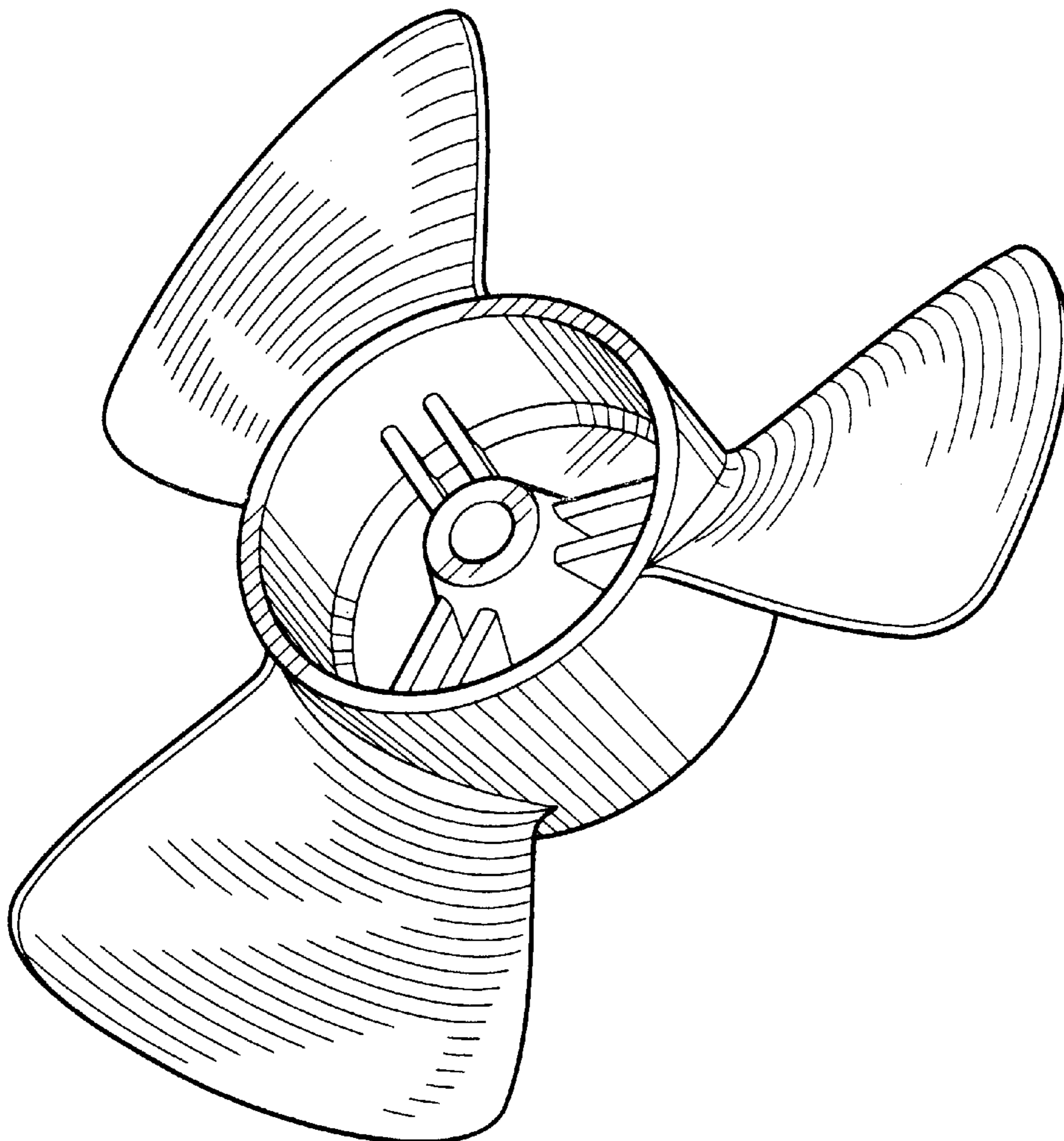

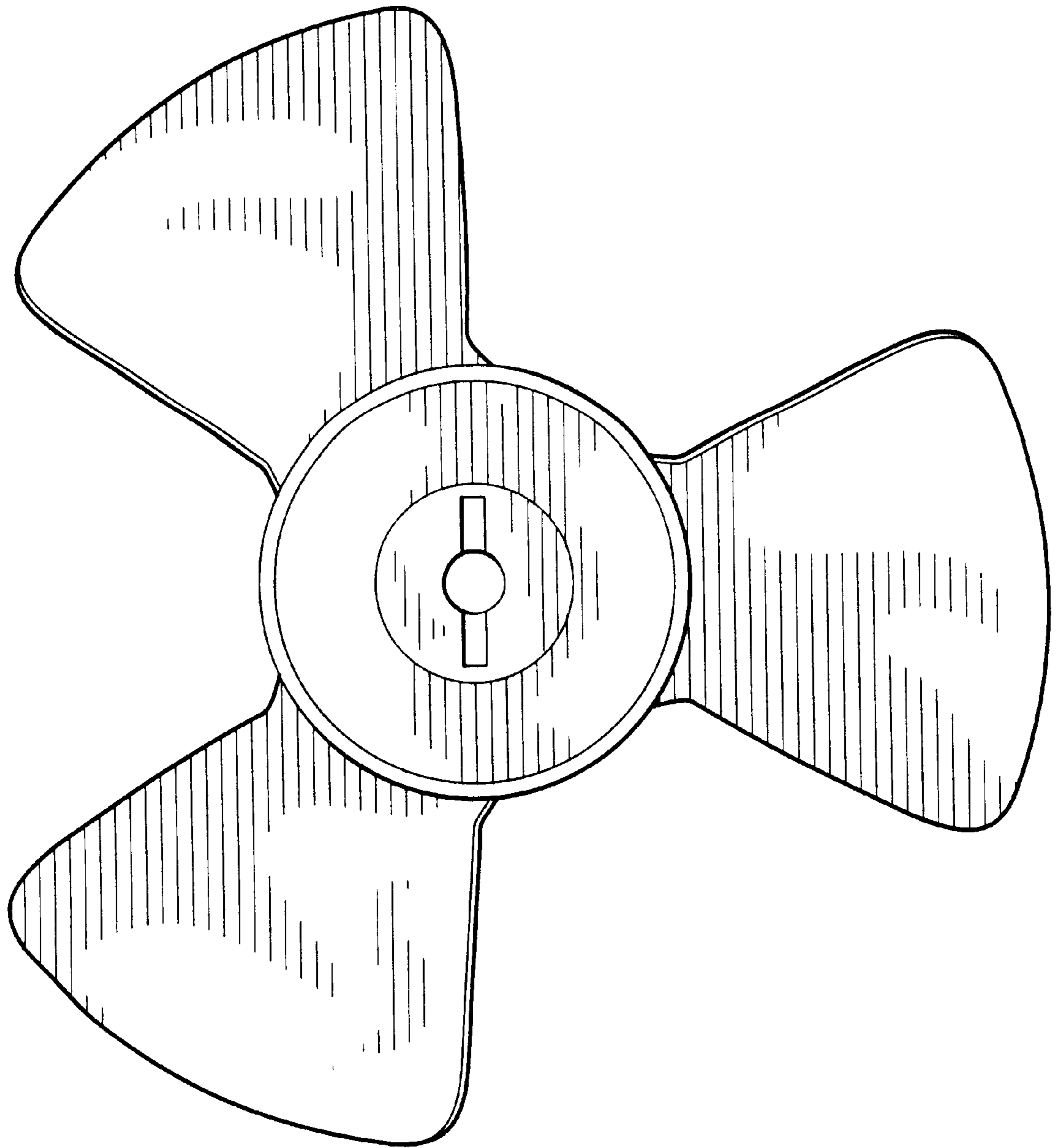

Fig. 1

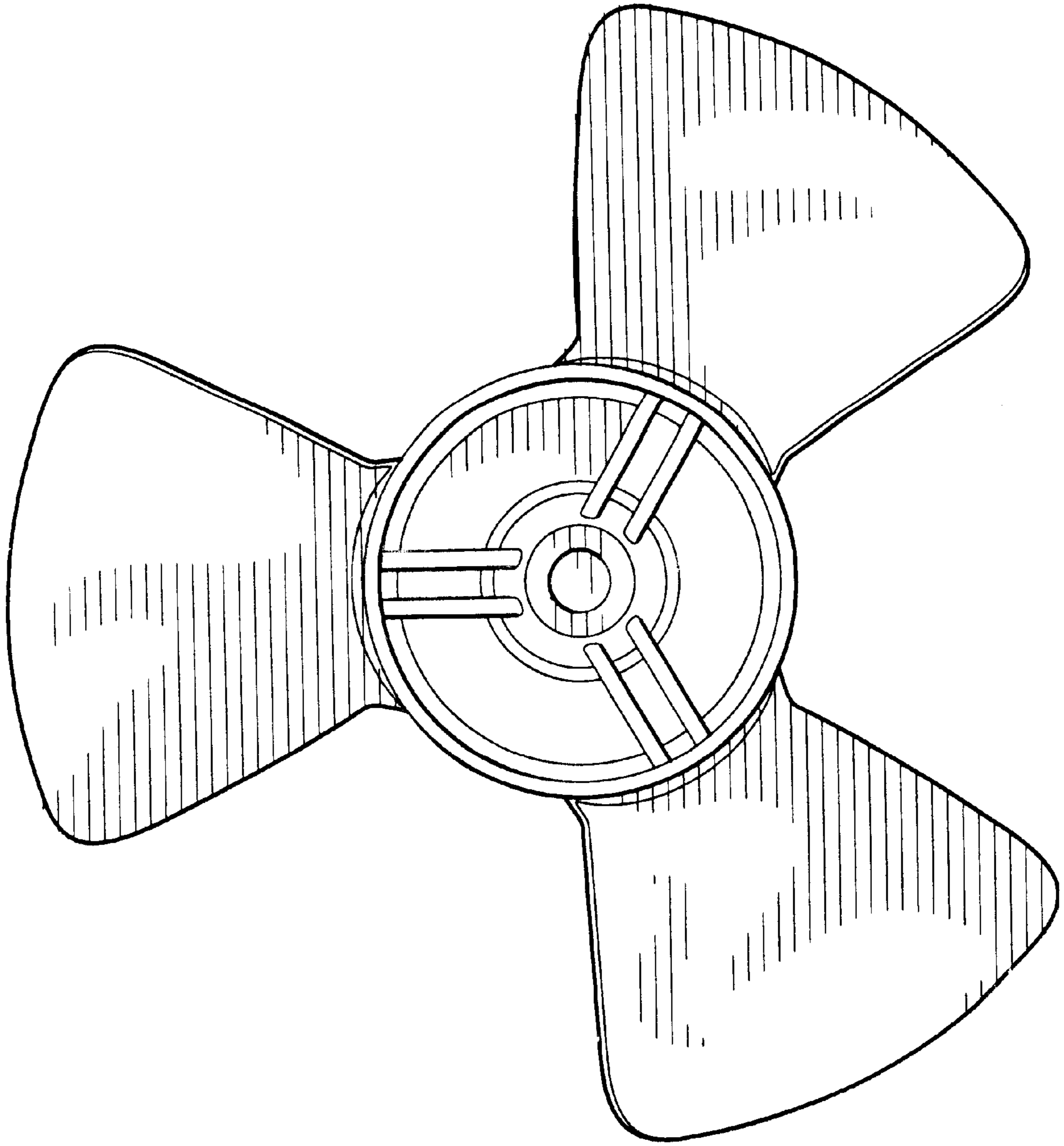

Fig. 2

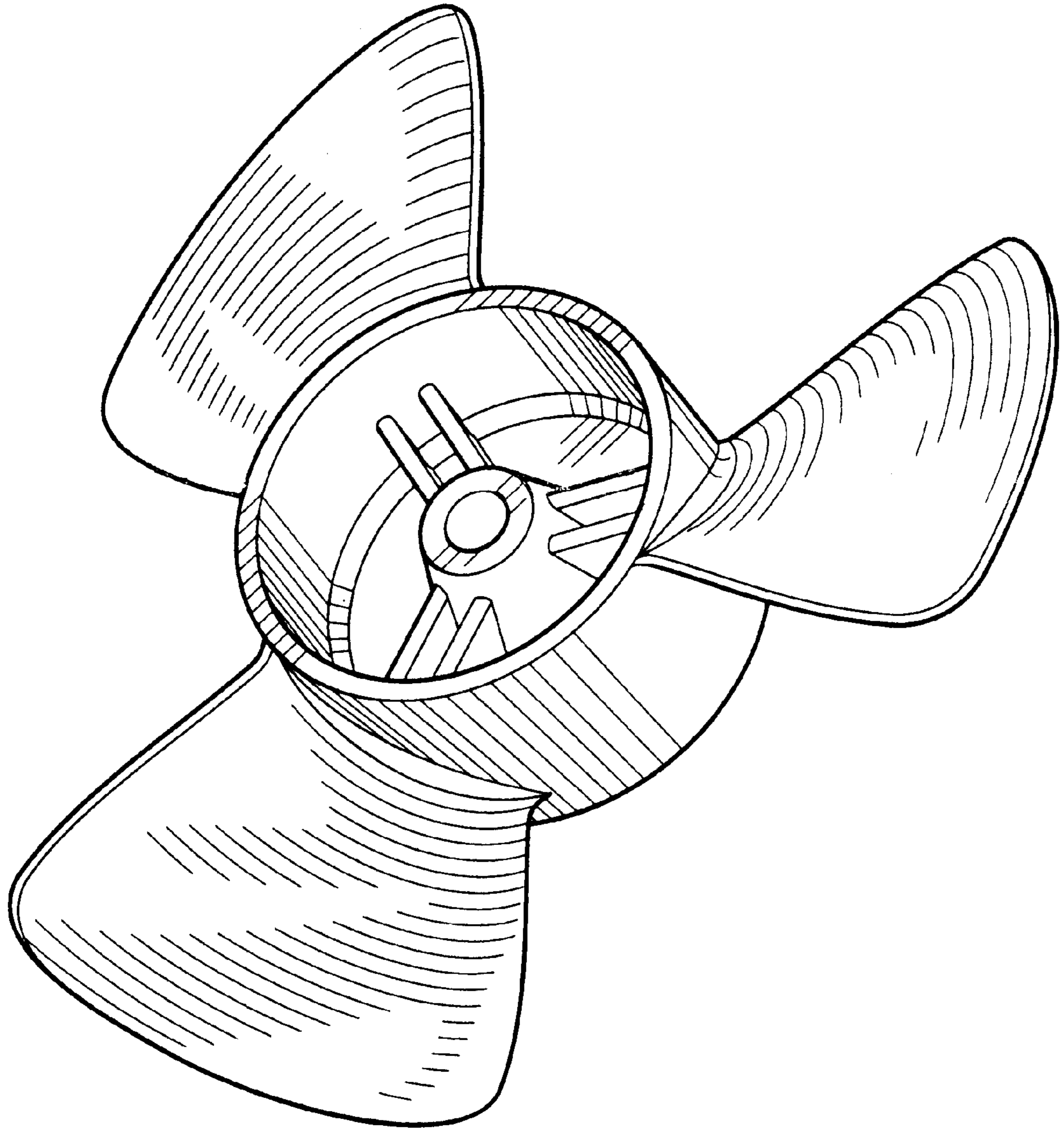

Fig. 3

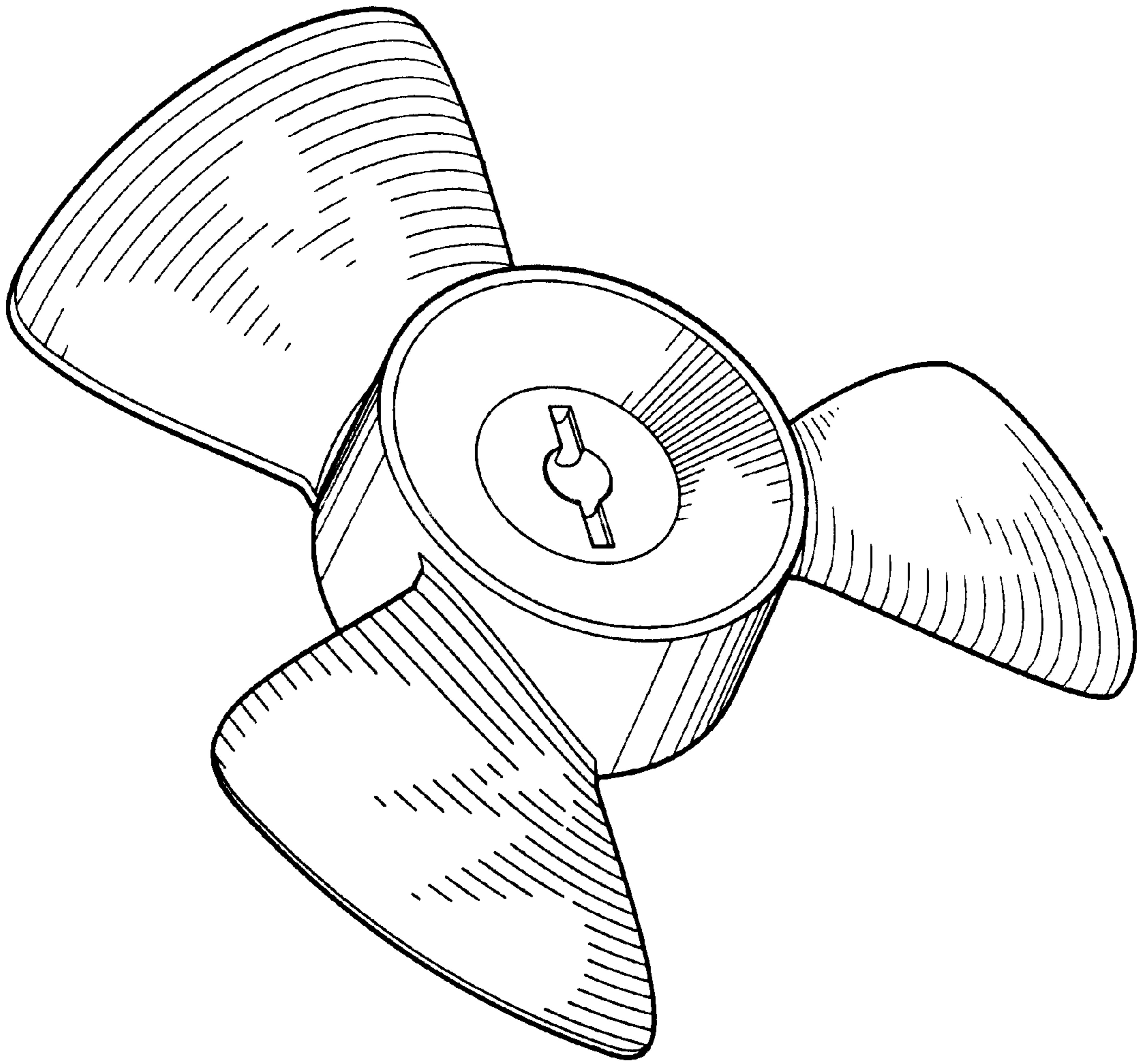

Fig. 4

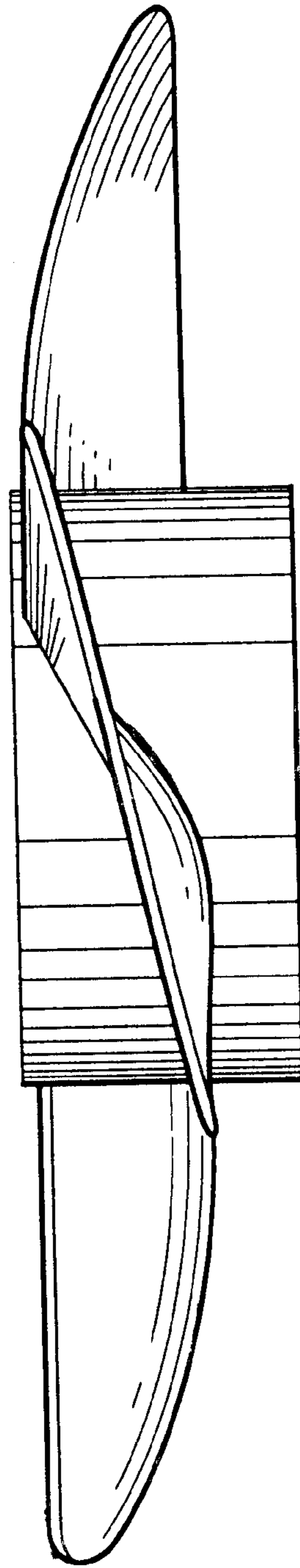

Fig. 5

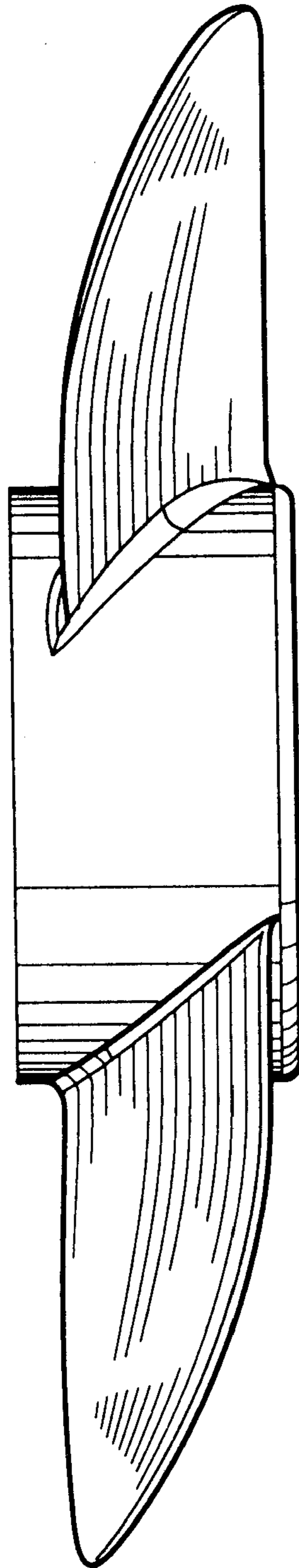

Fig. 6

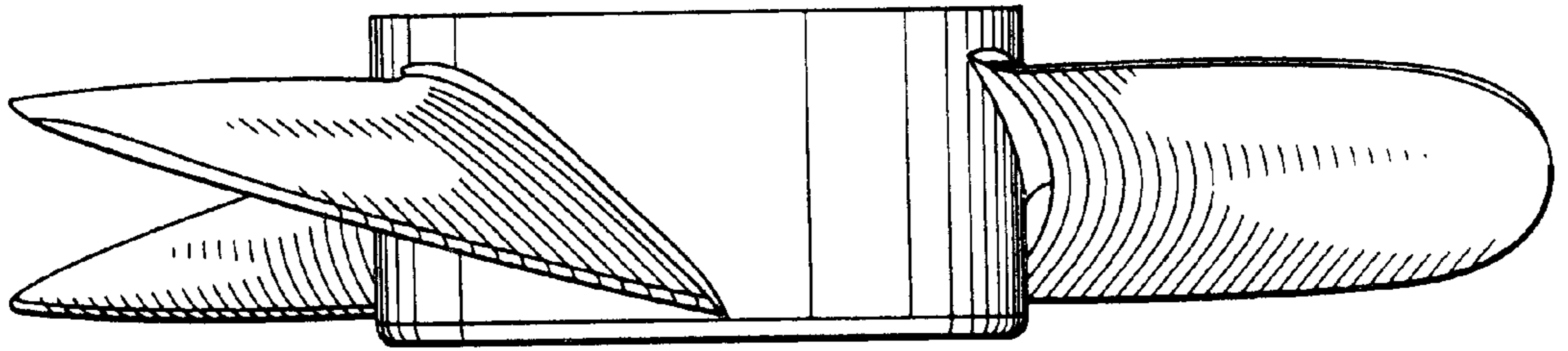

Fig. 7

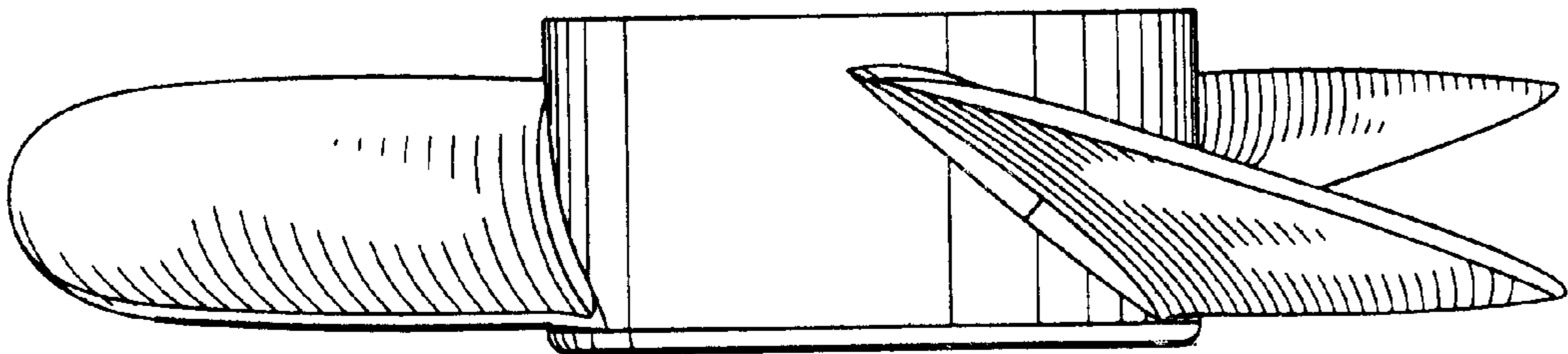

Fig. 8