



US00D473494S

(12) **United States Design Patent**
Lieberman

(10) **Patent No.:** **US D473,494 S**

(45) **Date of Patent:** **** Apr. 22, 2003**

(54) **LIQUID TRAILER**

(75) **Inventor:** **David Lieberman, Concord (CA)**

(73) **Assignee:** **Active Gear Co. of Canada Limited, Concord (CA)**

(**) **Term:** **14 Years**

(21) **Appl. No.:** **29/158,020**

(22) **Filed:** **Mar. 28, 2002**

(30) **Foreign Application Priority Data**

Mar. 11, 2002 (CA) 98863

(51) **LOC (7) Cl.** **12-08**

(52) **U.S. Cl.** **D12/95**

(58) **Field of Search** D12/95, 101; 280/63, 280/839, 789, 837, 482, 656; 296/171, 173

(56) **References Cited**

U.S. PATENT DOCUMENTS

D337,080 S * 7/1993 Schlake

D350,839 S * 9/1994 Ledesma D12/95 X
D375,921 S * 11/1996 Kunkle D12/101
D383,092 S * 9/1997 Garzancich D12/95
D434,701 S * 12/2000 Patmont D12/101

* cited by examiner

Primary Examiner—Melody N. Brown

(74) *Attorney, Agent, or Firm*—Riches, McKenzie & Herbert LLP

(57) **CLAIM**

The ornamental design for a liquid trailer, as shown.

DESCRIPTION

FIG. 1—is a side view of a liquid trailer showing my new design.

FIG. 2—is a side view showing the opposite side of FIG. 1.

FIG. 3—is a top view thereof.

FIG. 4—is a bottom view thereof.

FIG. 5—is a rear view thereof.

FIG. 6—is a front view thereof; and,

FIG. 7—is a perspective view thereof.

1 Claim, 3 Drawing Sheets

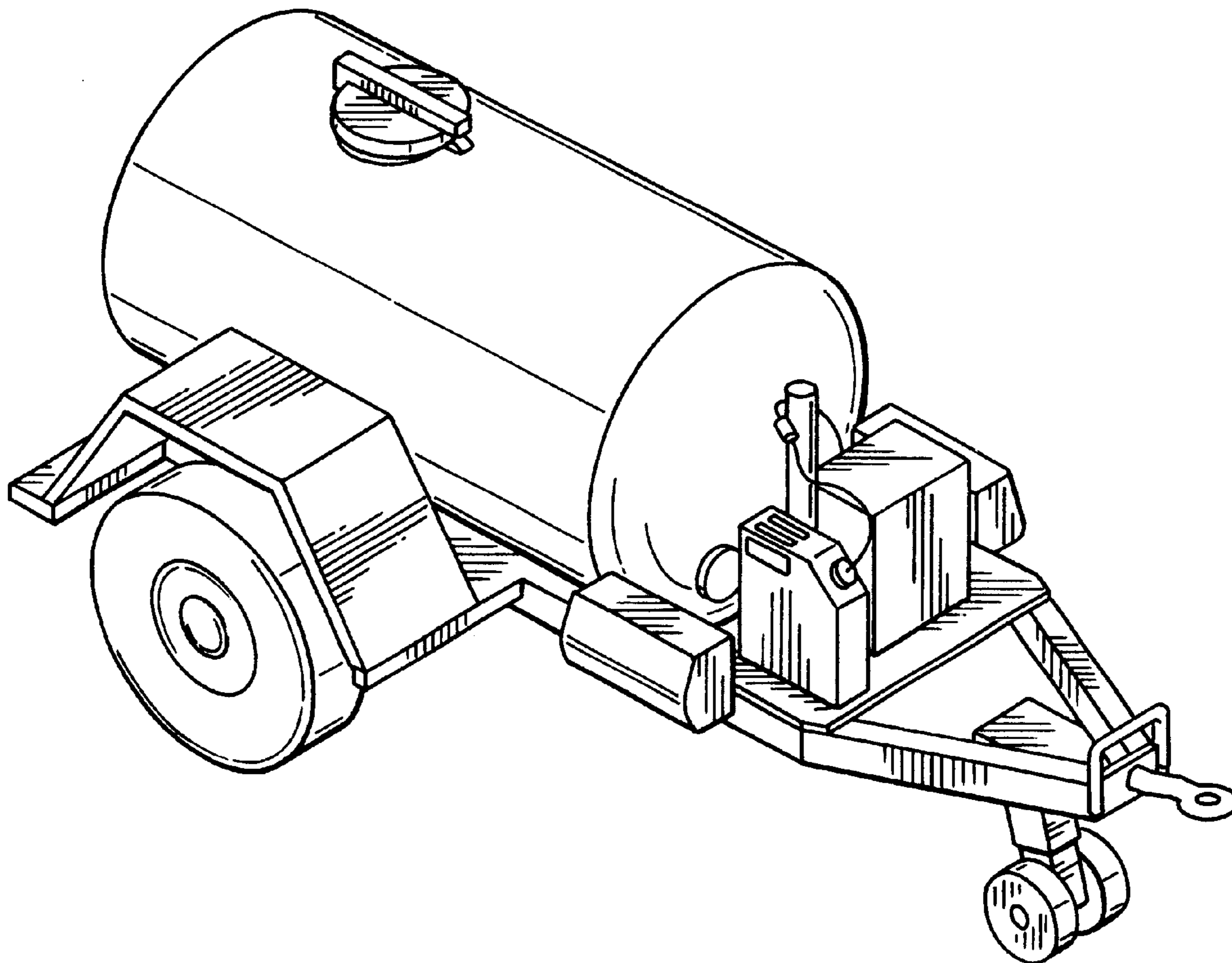

FIG. 1.

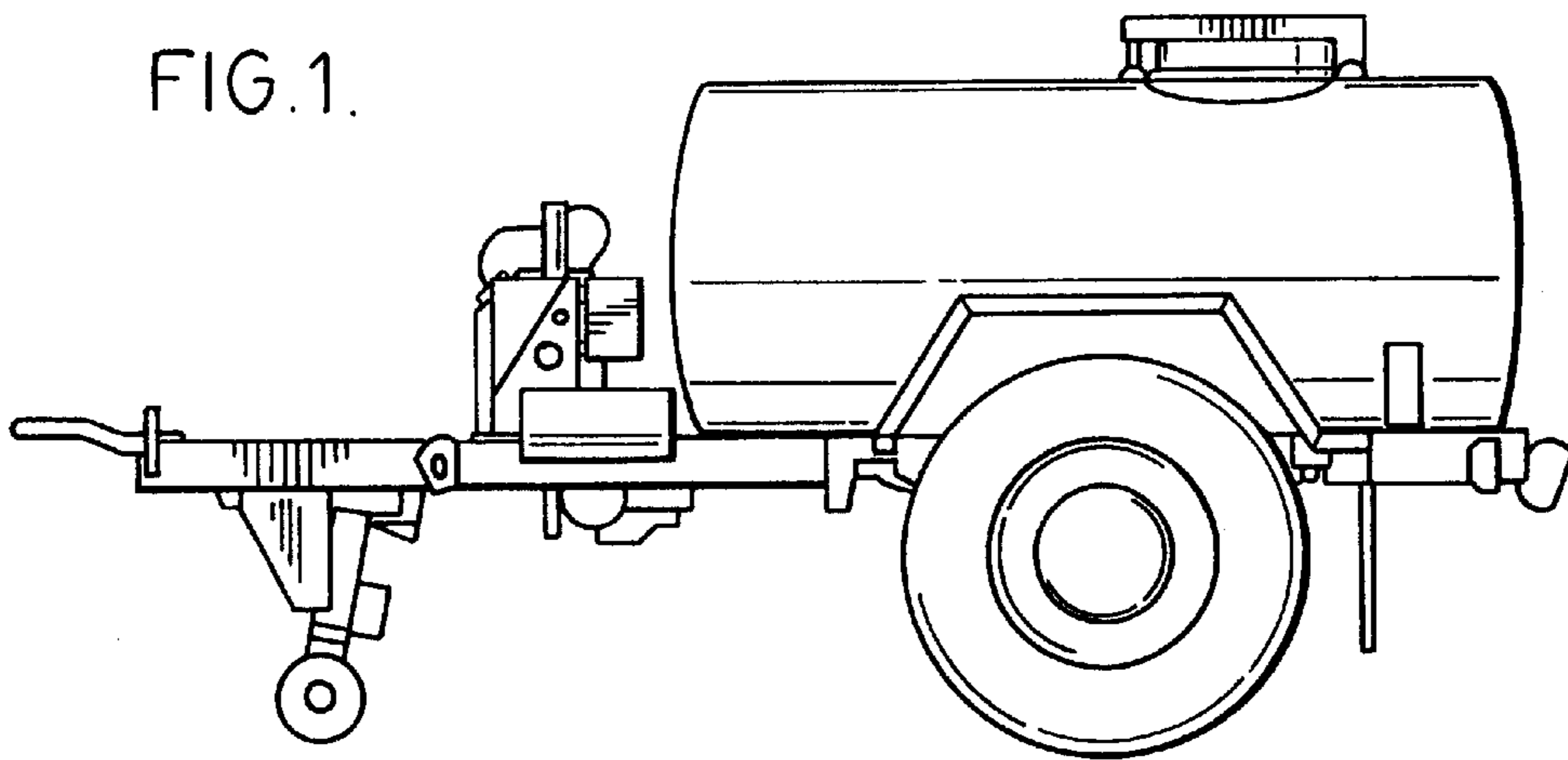

FIG. 2.

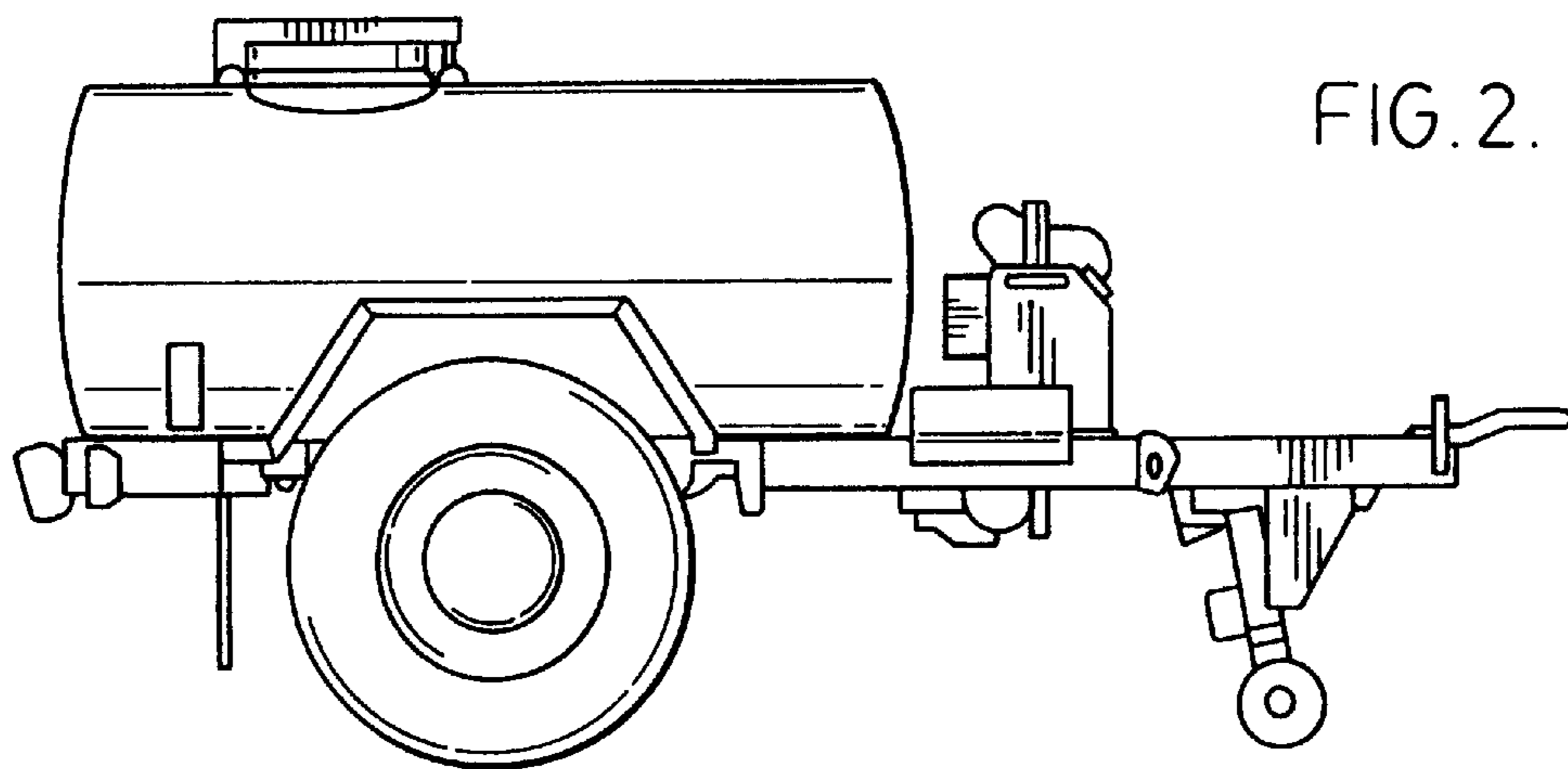

FIG. 3.

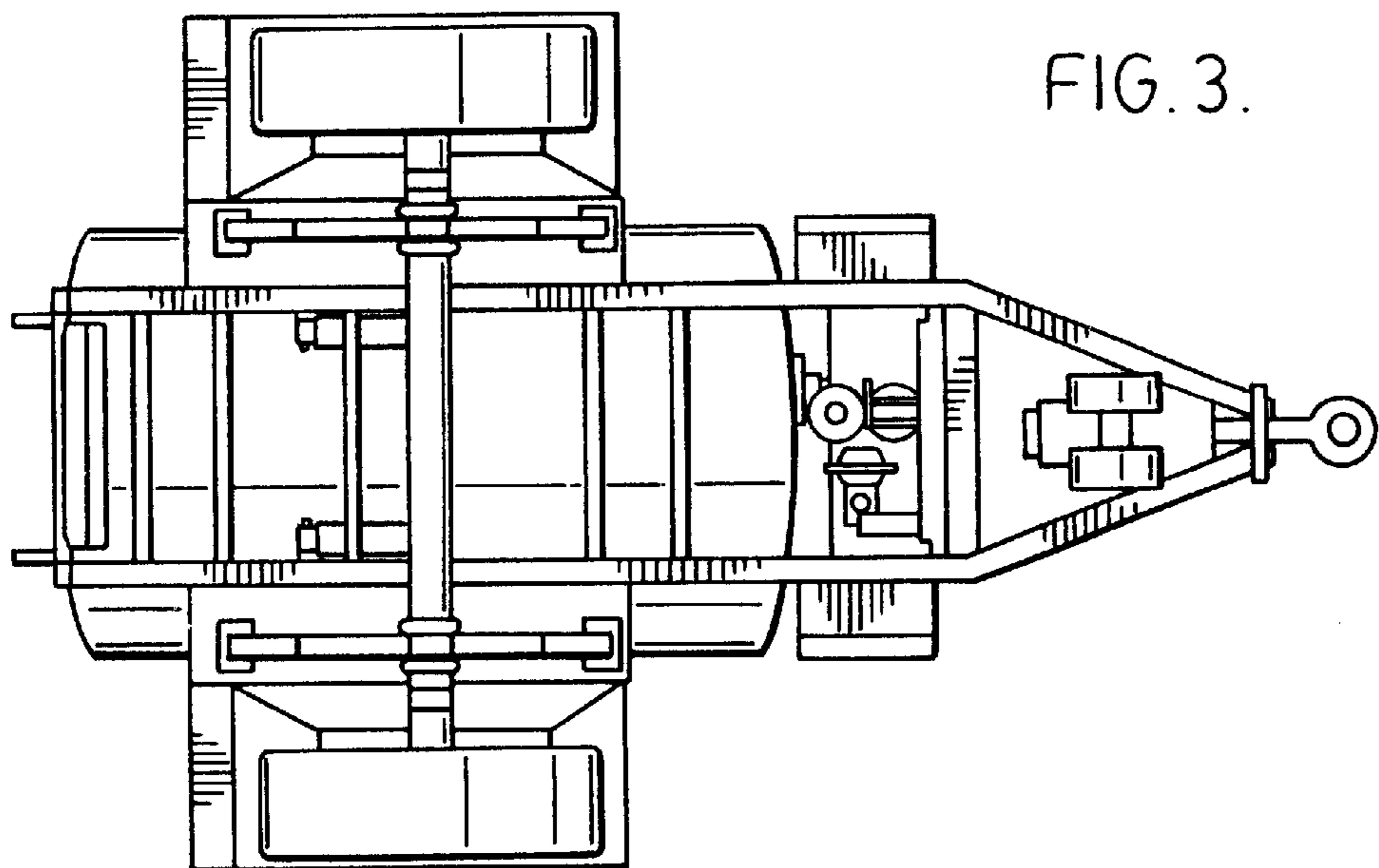

FIG. 4.

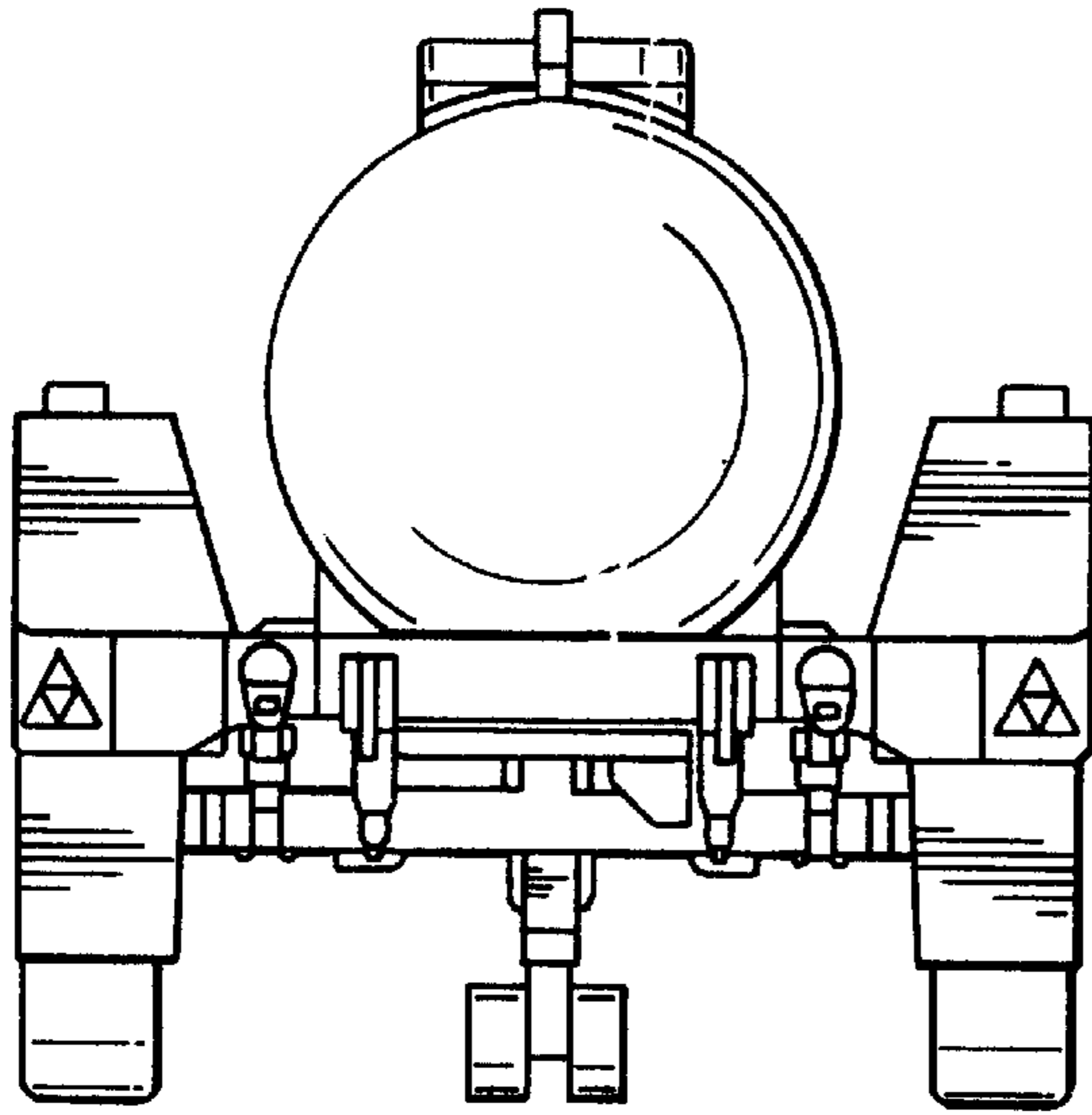
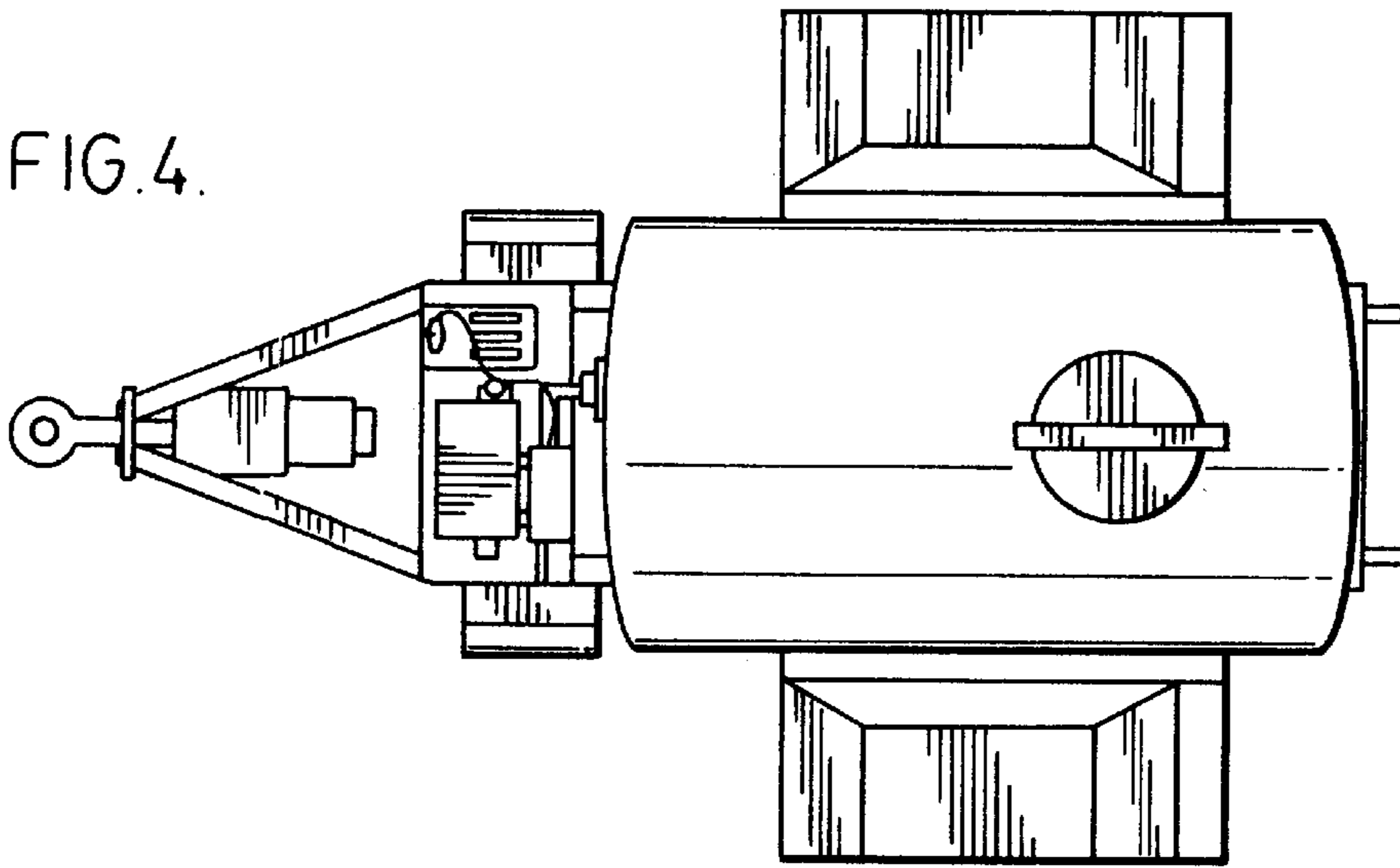
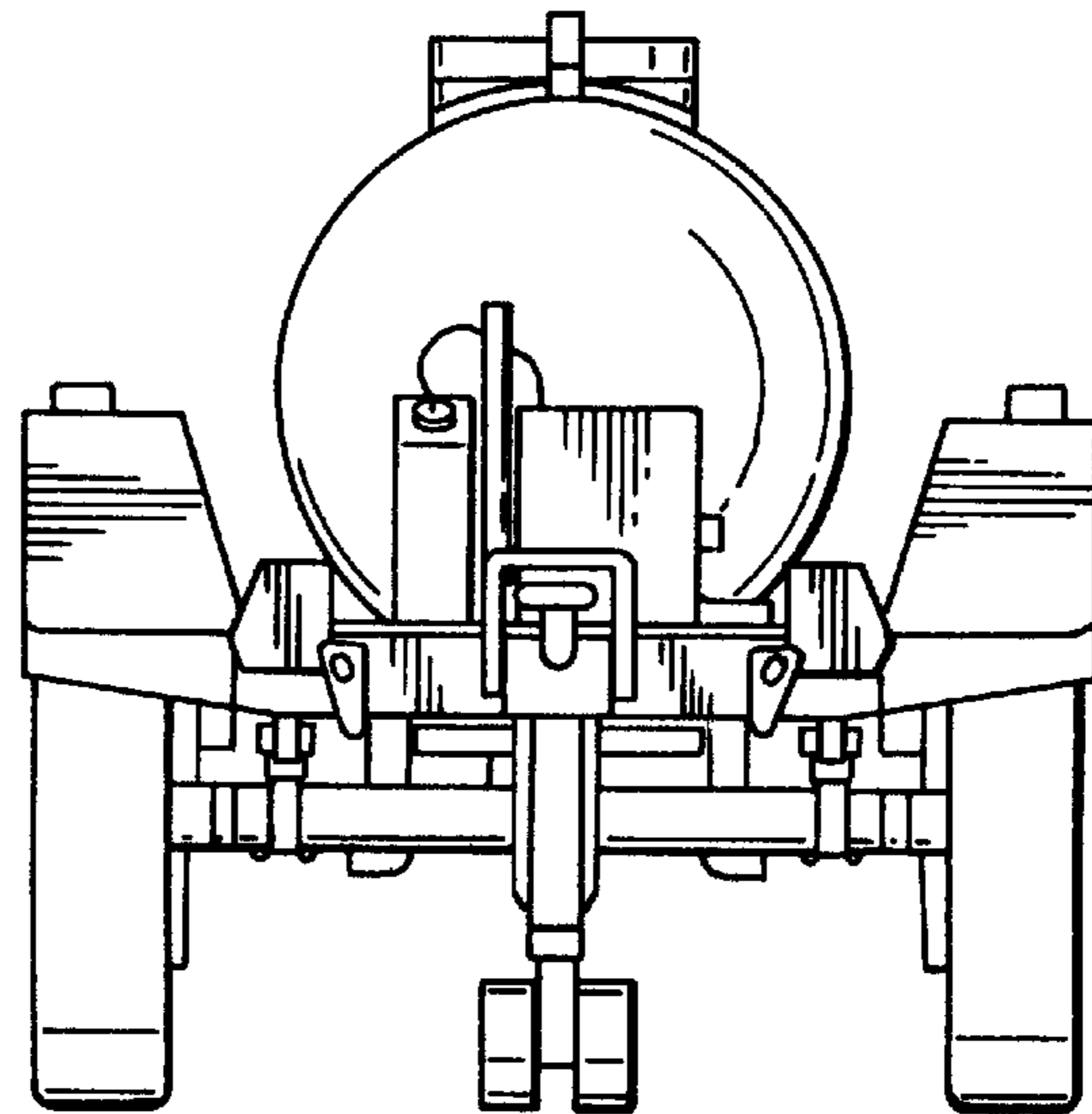

FIG. 5.

FIG. 6.



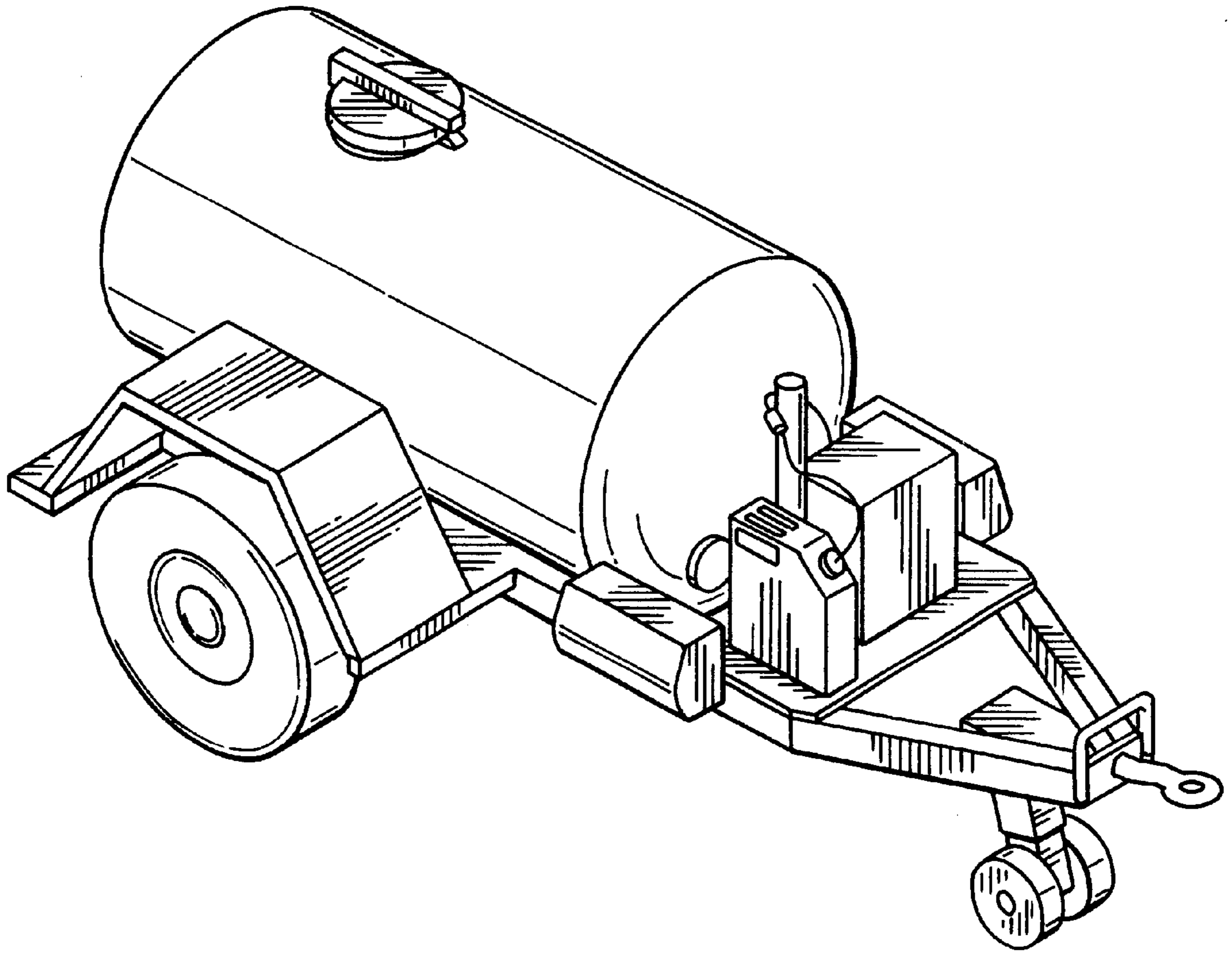

FIG. 7.