



US00D473269S

(12) **United States Design Patent**  
**Tsuda**

(10) **Patent No.:** **US D473,269 S**

(45) **Date of Patent:** **\*\* Apr. 15, 2003**

(54) **GAME MACHINE**

(75) **Inventor:** **Kimio Tsuda, Tokyo (JP)**

(73) **Assignee:** **Sega Corporation, Tokyo (JP)**

(\*\*) **Term:** **14 Years**

(21) **Appl. No.:** **29/160,079**

(22) **Filed:** **May 2, 2002**

(30) **Foreign Application Priority Data**

Nov. 9, 2001 (JP) ..... 2001-033061

(51) **LOC (7) Cl.** ..... **21-01**

(52) **U.S. Cl.** ..... **D21/329**

(58) **Field of Search** ..... D21/324-328,  
D21/333, 369; 273/148 B; 463/1, 10-17,  
29-35, 46, 47, 49, 26, 27, 28

(56) **References Cited**

**U.S. PATENT DOCUMENTS**

D280,836 S \* 10/1985 Ludzia et al. .... D21/325  
D312,666 S \* 12/1990 Lempke et al. .... D21/327  
5,456,468 A \* 10/1995 Stringfellow et al. .... 463/46

5,813,914 A \* 9/1998 McKay et al. .... 463/46  
5,851,147 A \* 12/1998 Stupak et al. .... 463/13  
D411,582 S \* 6/1999 Muraki et al. .... D21/325  
6,201,532 B1 \* 3/2001 Tode et al. .... 463/46  
D460,120 S \* 7/2002 Lynch ..... D21/325  
D460,496 S \* 7/2002 Cole ..... D21/325

\* cited by examiner

*Primary Examiner*—Prabhakar Deshmukh

(74) *Attorney, Agent, or Firm*—Ladas & Parry

(57) **CLAIM**

The ornamental design for a game machine, as shown and described.

**DESCRIPTION**

FIG. 1 is a perspective view of a game machine showing my new design;  
FIG. 2 is a front view thereof;  
FIG. 3 is a rear view thereof;  
FIG. 4 is a top view thereof;  
FIG. 5 is a bottom view thereof;  
FIG. 6 is a right side view thereof; and,  
FIG. 7 is a left side view thereof.

**1 Claim, 4 Drawing Sheets**

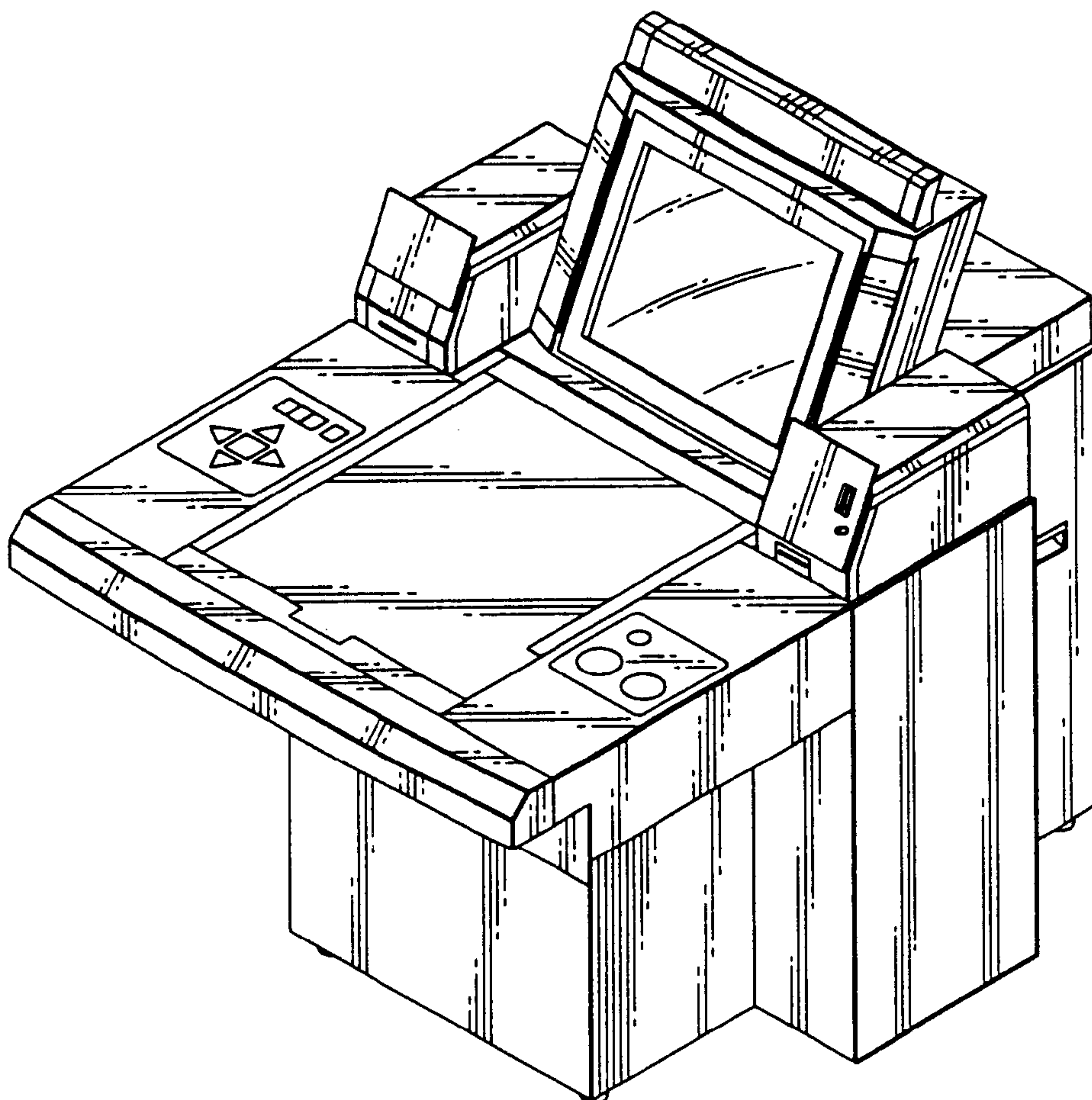

FIG. 1

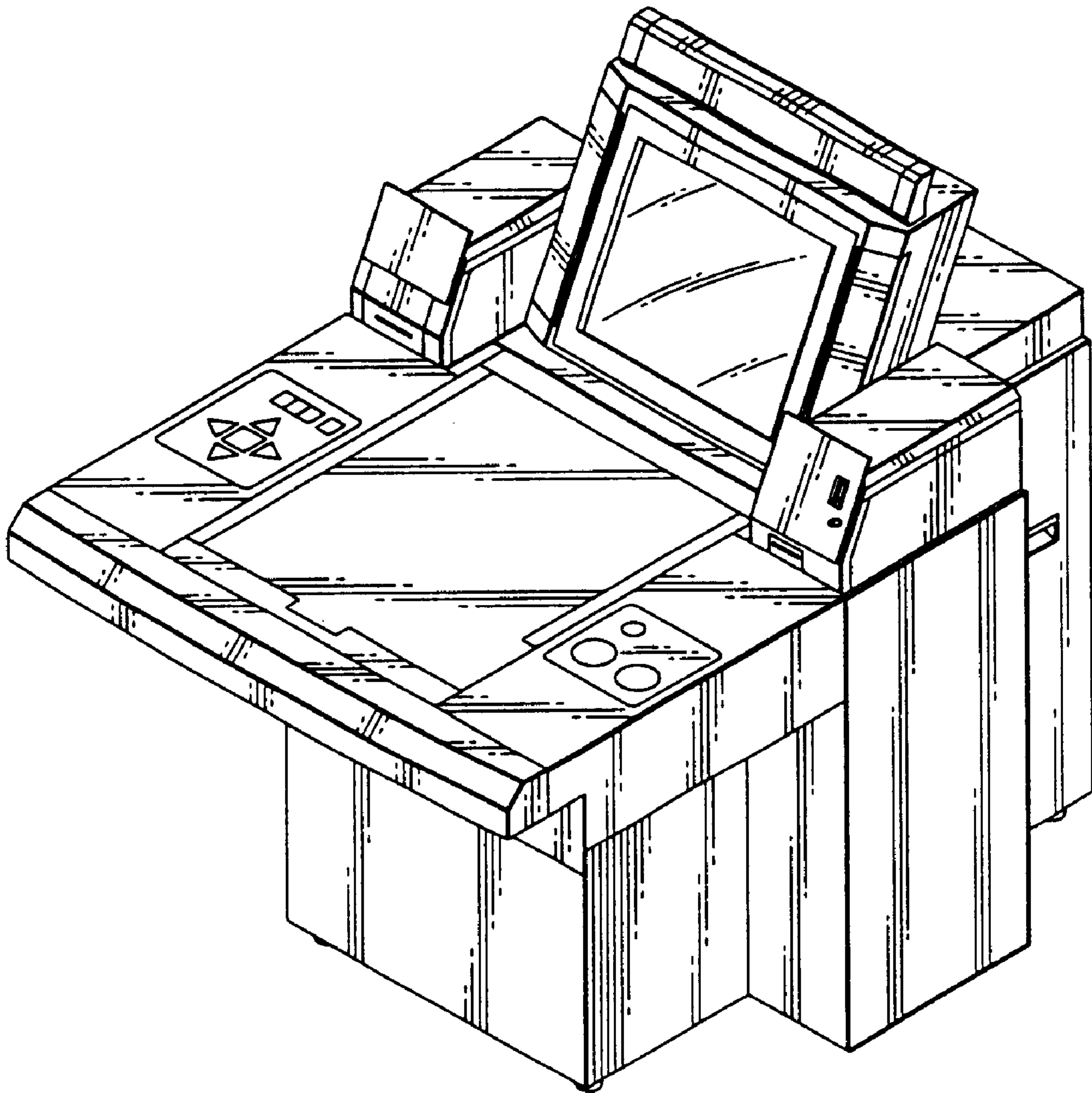

FIG.2

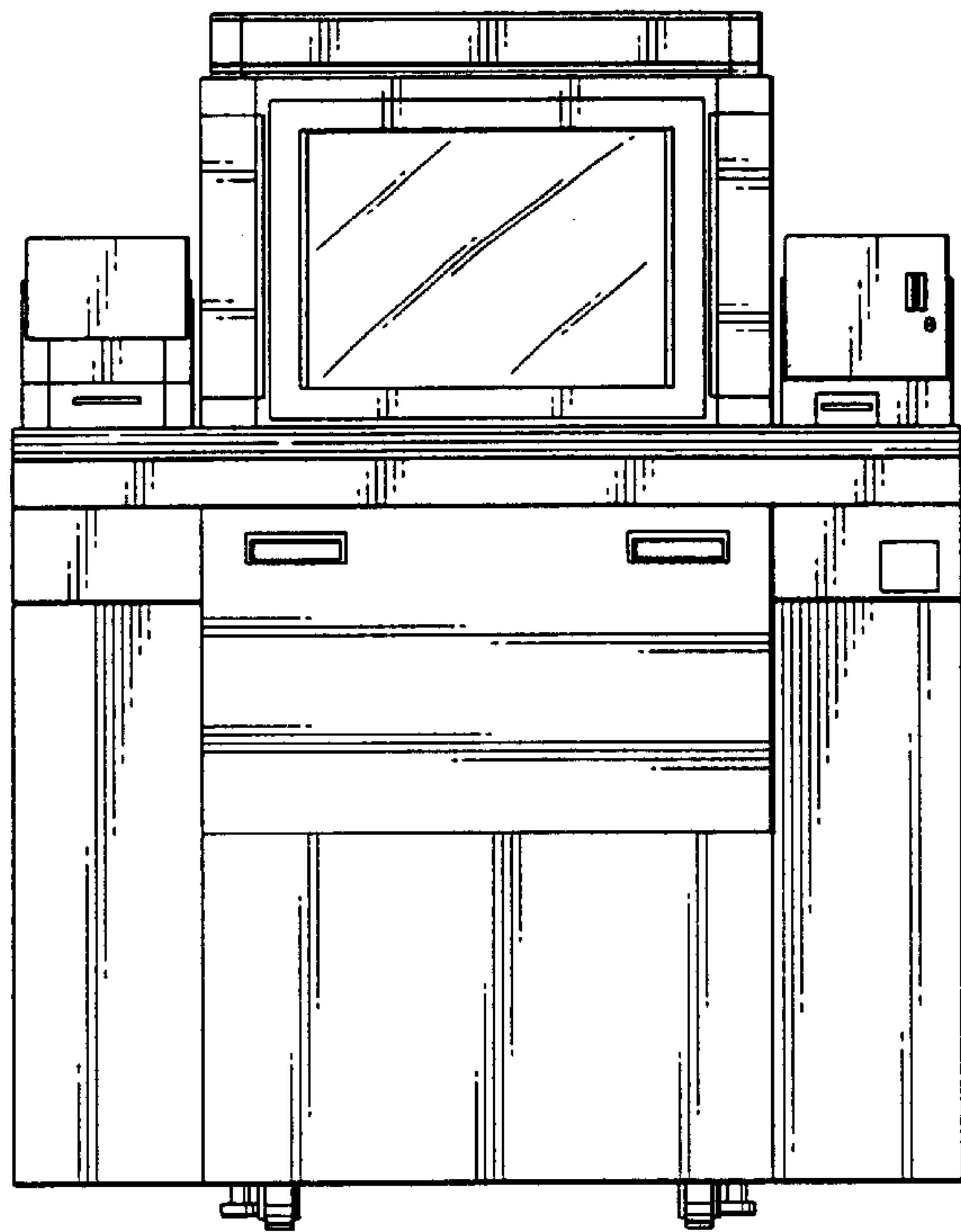

FIG.3

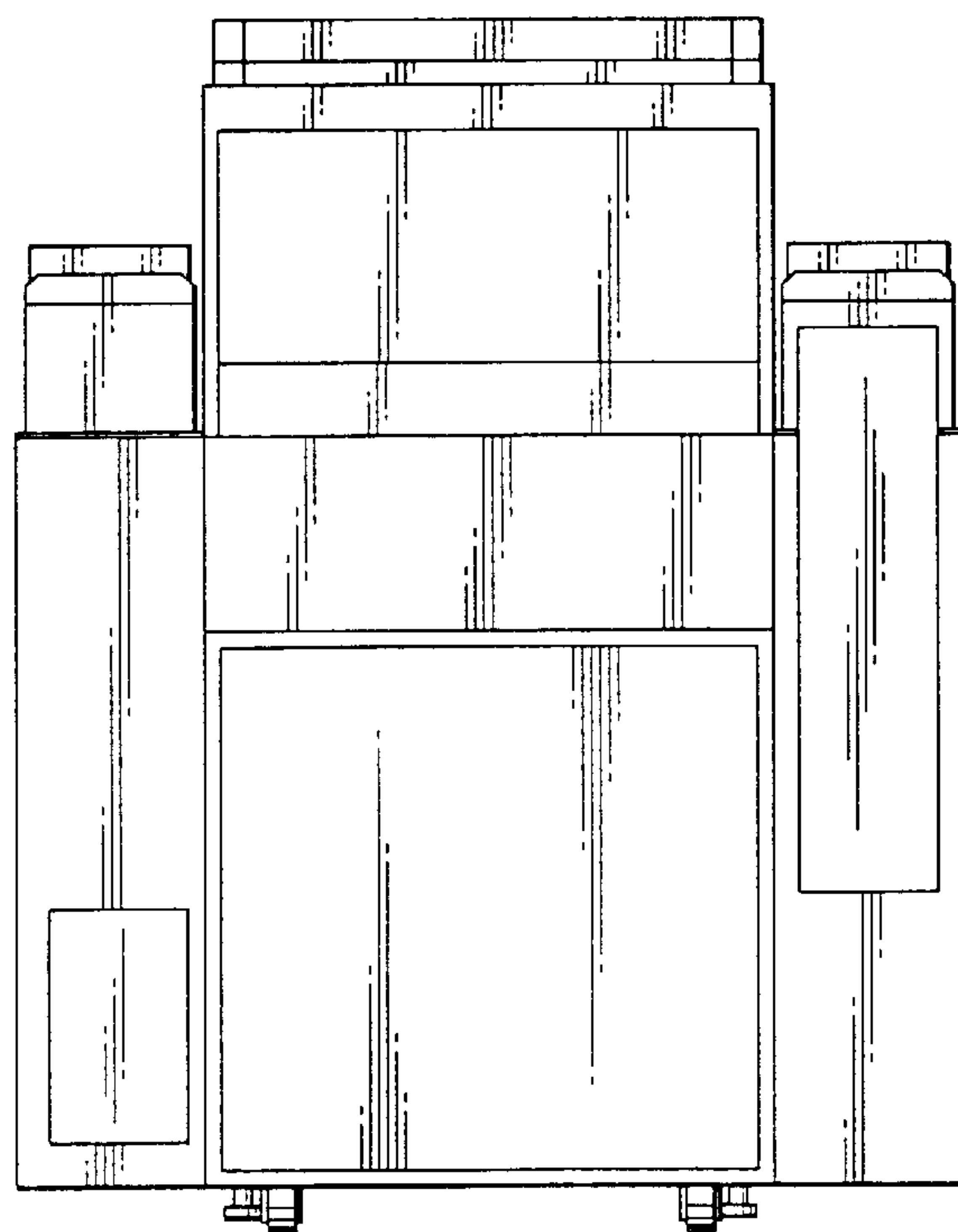

FIG. 4

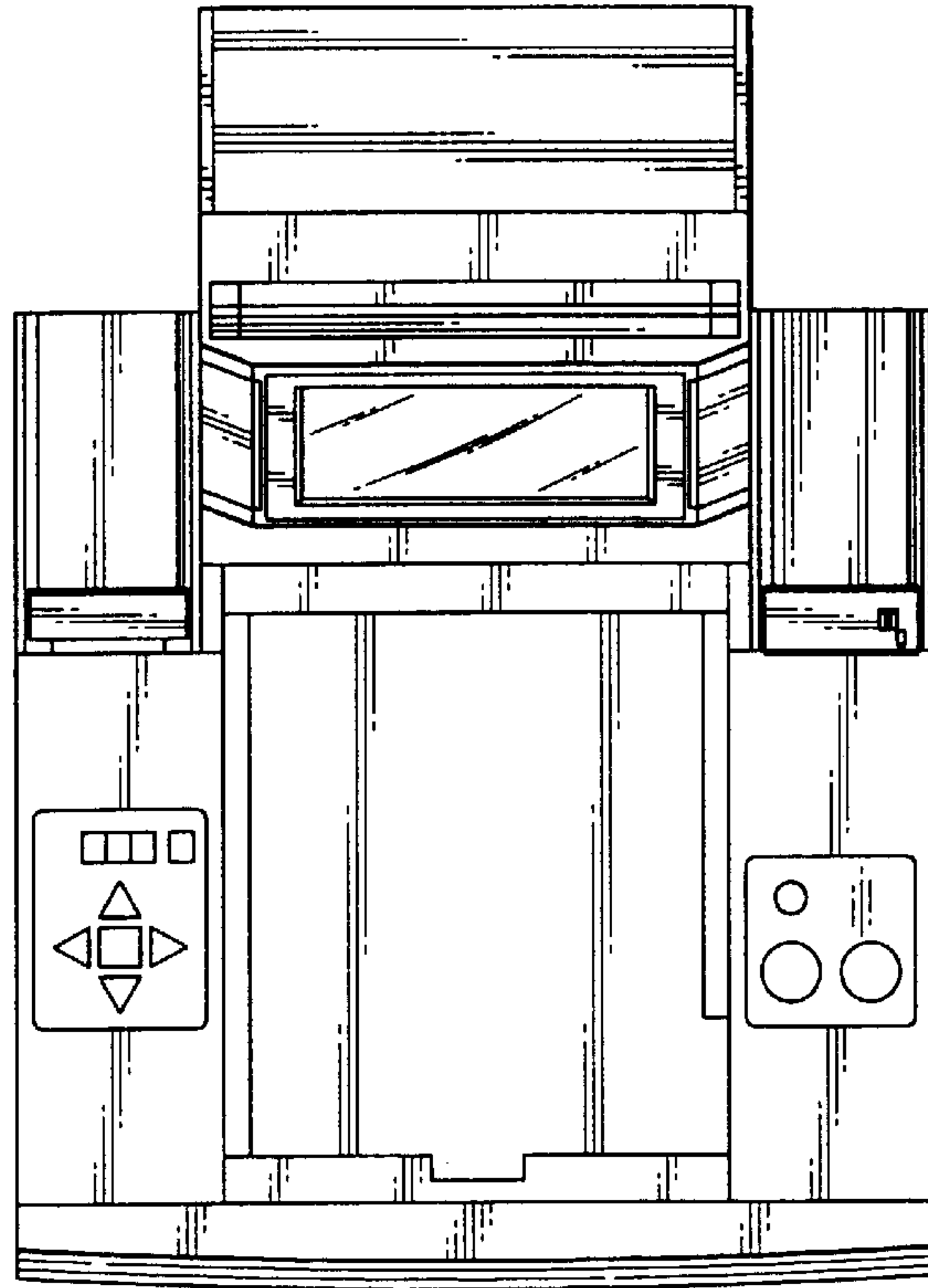

FIG. 5

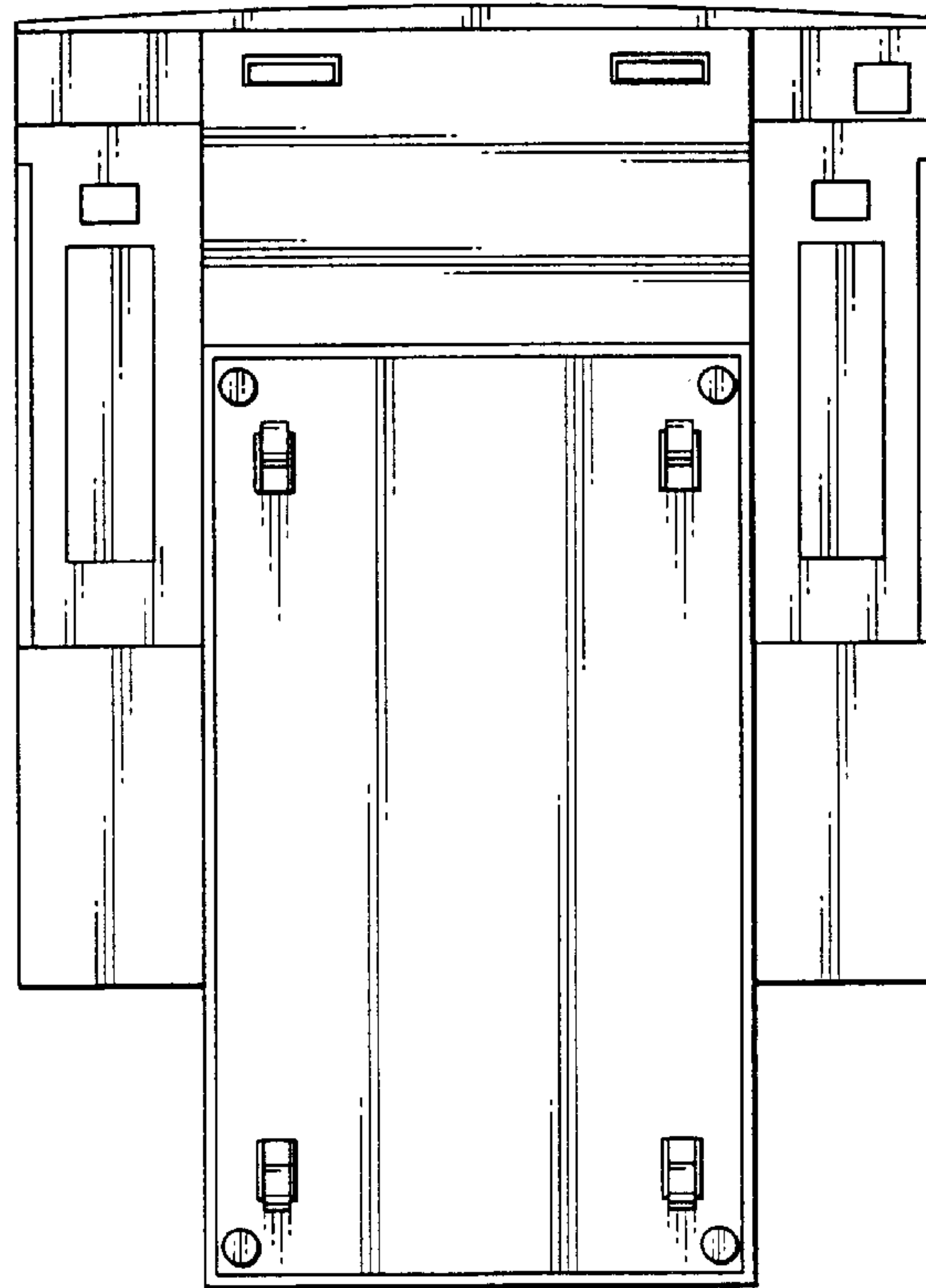

FIG.6

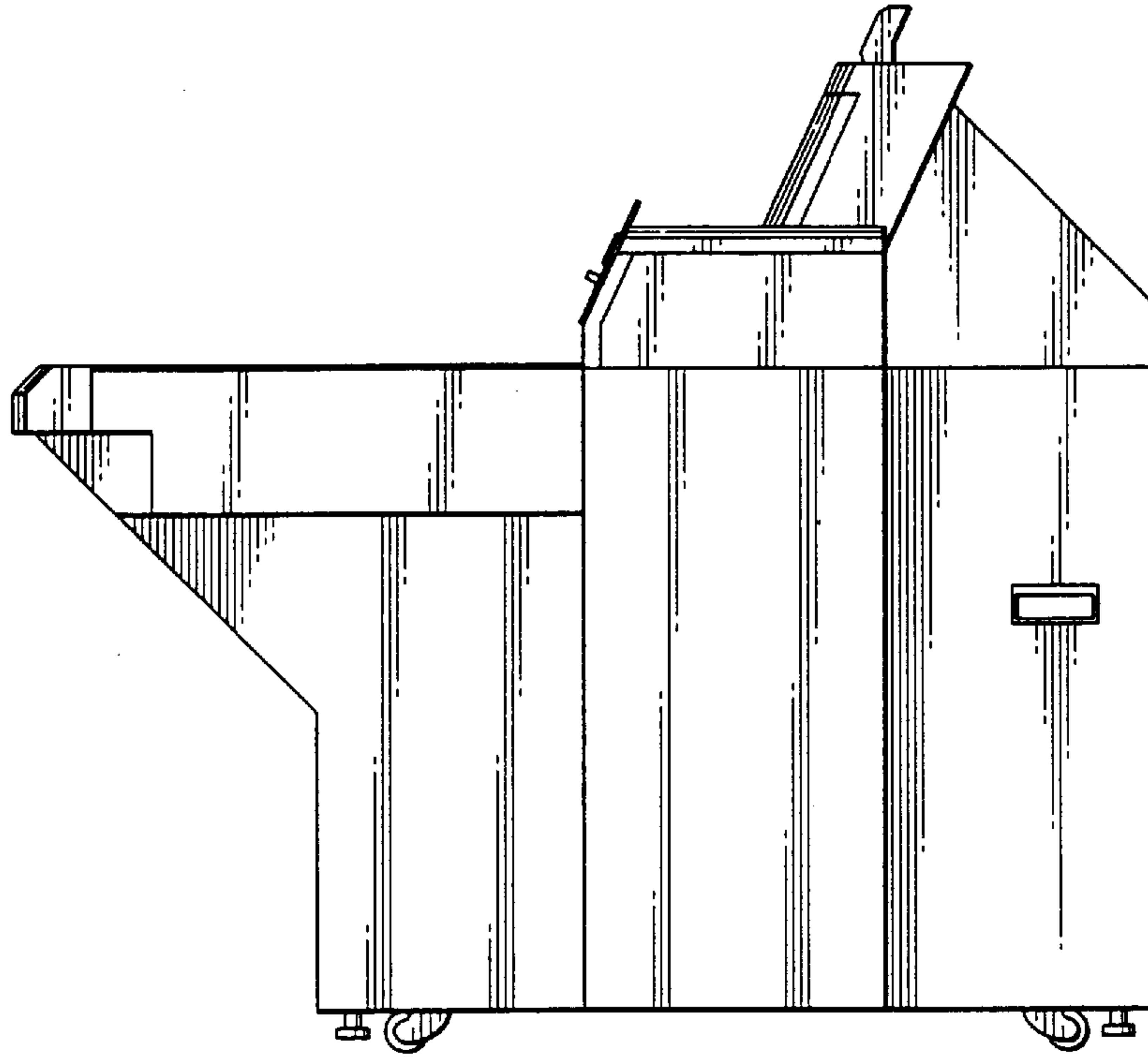

FIG.7

