



US00D473253S

(12) **United States Design Patent**  
**Shimamoto**

(10) **Patent No.:** **US D473,253 S**

(45) **Date of Patent:** **\*\* Apr. 15, 2003**

(54) **VIDEO PROJECTOR**

(75) Inventor: **Yasutaka Shimamoto**, Tochigi-ken (JP)

(73) Assignee: **Sharp Kabushiki Kaisha**, Osaka (JP)

(\*\*) Term: **14 Years**

(21) Appl. No.: **29/169,040**

(22) Filed: **Oct. 15, 2002**

(30) **Foreign Application Priority Data**

Apr. 18, 2002 (JP) ..... 2002-010488

(51) **LOC (7) Cl.** ..... **16-02**

(52) **U.S. Cl.** ..... **D16/231; D16/225**

(58) **Field of Search** ..... D16/205, 208,  
D16/221, 225, 230, 231, 234; D21/514;  
352/242, 243; 353/115, 119, 122

(56) **References Cited**

**U.S. PATENT DOCUMENTS**

- D343,850 S 2/1994 Saeki et al.
- D356,103 S 3/1995 Saeki et al.
- D364,416 S 11/1995 Saeki et al.
- D365,587 S 12/1995 Saeki et al.
- D387,795 S 12/1997 Sakamoto
- D388,111 S 12/1997 Iida
- D391,592 S 3/1998 Sakamoto et al.
- D398,321 S 9/1998 Iida
- D398,622 S 9/1998 Saeki et al.
- D412,926 S 8/1999 Saeki et al.
- D419,172 S 1/2000 Saeki et al.
- D420,031 S \* 2/2000 Yamano ..... D16/230
- D424,090 S \* 5/2000 Ko et al. .... D16/231

- D428,619 S 7/2000 Saeki et al.
- D434,430 S 11/2000 Saeki et al.
- D437,337 S \* 2/2001 Kawasaki et al. .... D16/230
- D437,607 S \* 2/2001 Takahashi ..... D16/230
- D441,387 S 5/2001 Saeki et al.
- D449,060 S 10/2001 Saeki et al.
- D450,076 S \* 11/2001 Fujimaki ..... D16/230
- D454,360 S 3/2002 Shimizu et al.
- D457,179 S 5/2002 Saeki et al.
- 6,488,380 B1 \* 12/2002 Fujimori ..... 353/119

**OTHER PUBLICATIONS**

News and Information, Sony Press Release, Aug. 1999 (projector VPL-CX10).\*

\* cited by examiner

*Primary Examiner*—Adir Aronovich  
(74) *Attorney, Agent, or Firm*—Nixon & Vanderhye

(57) **CLAIM**

The ornamental design for a video projector, as shown and described.

**DESCRIPTION**

FIG. 1 is a top, front and right side perspective view of a video projector according to my design;  
FIG. 2 is a front elevational view thereof;  
FIG. 3 is a rear elevational view thereof;  
FIG. 4 is a top plan view thereof;  
FIG. 5 is a bottom plan view thereof;  
FIG. 6 is a right side elevational view thereof; and,  
FIG. 7 is a left side elevational view thereof.

**1 Claim, 5 Drawing Sheets**

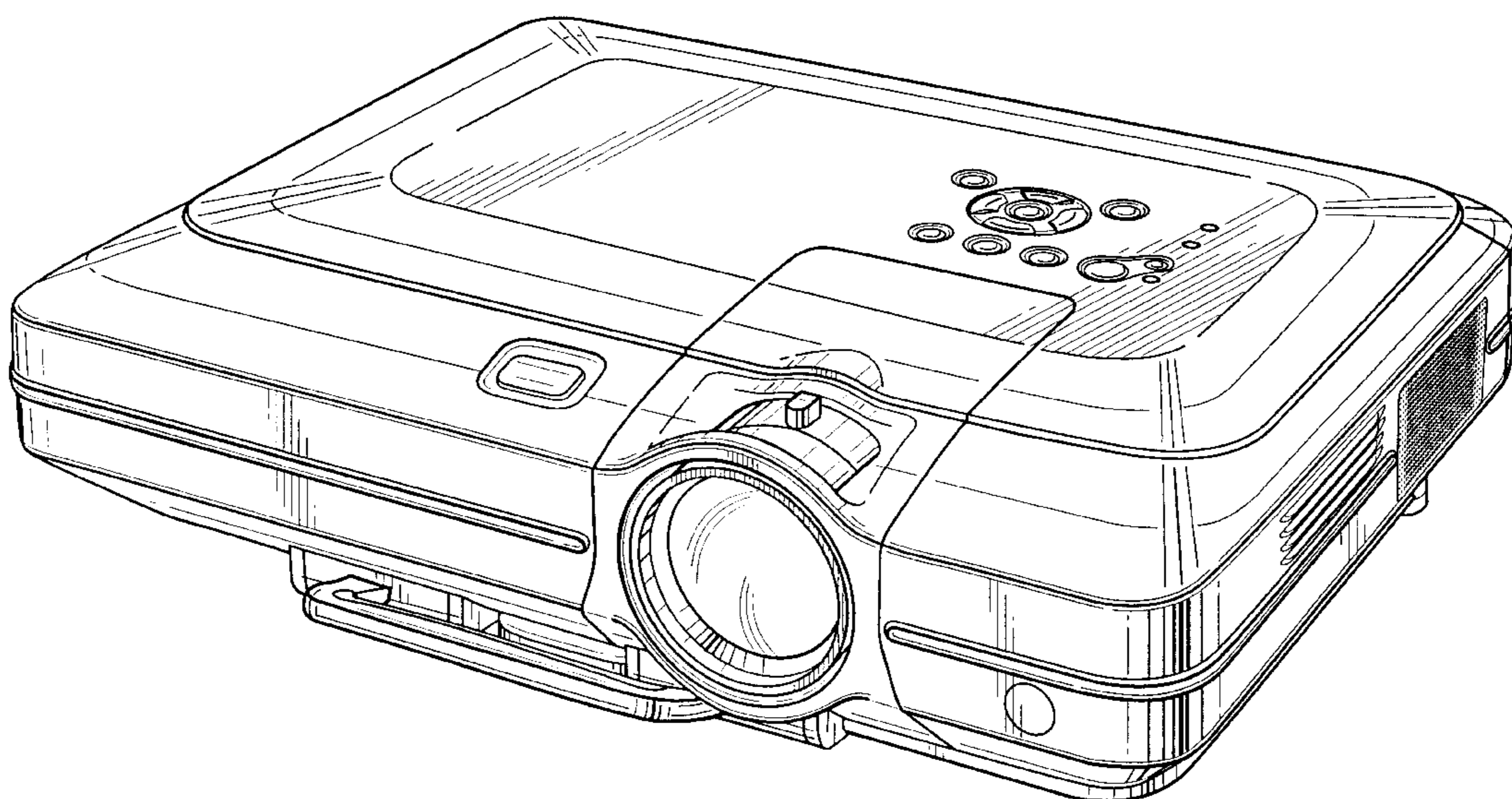

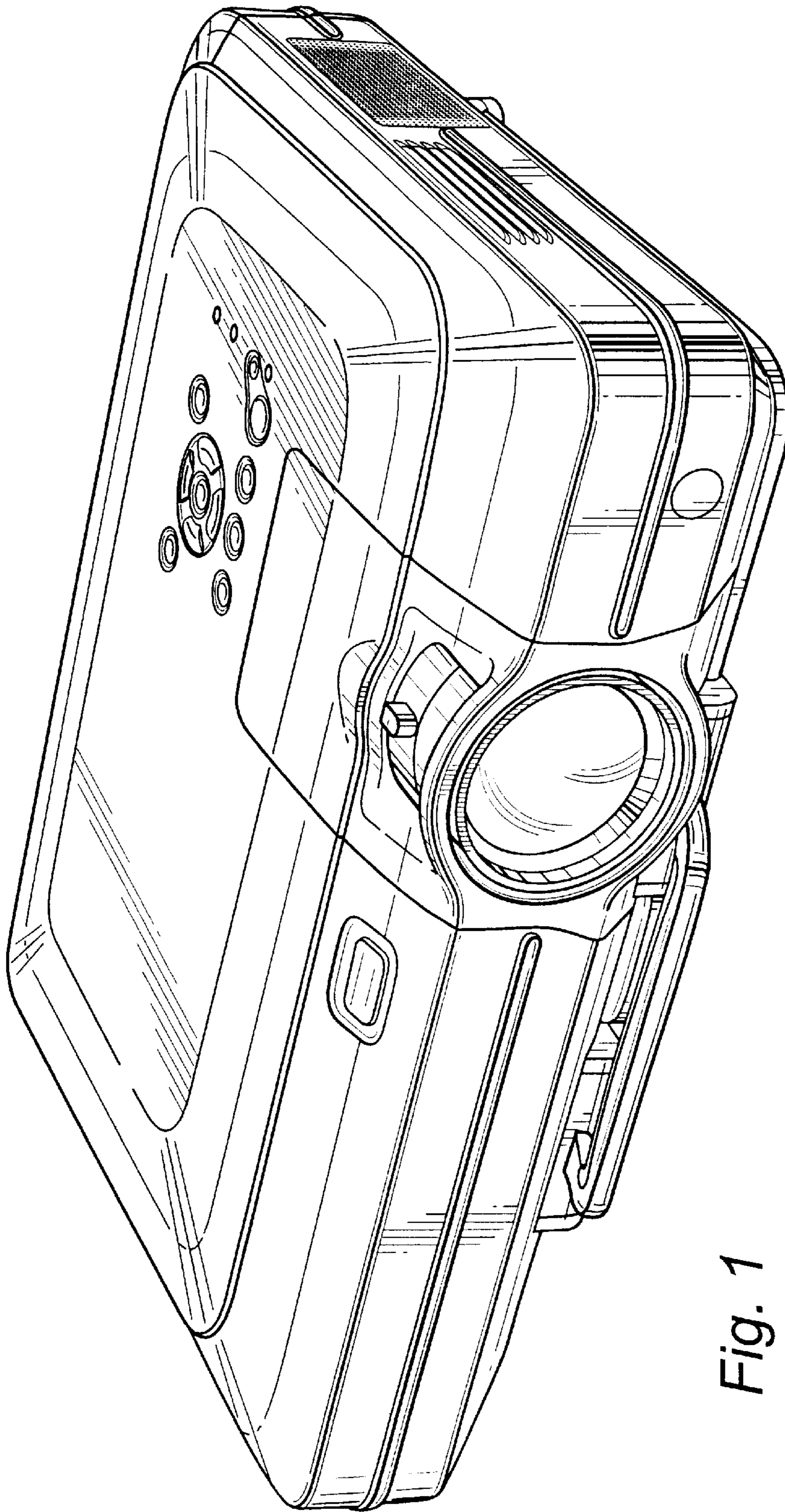
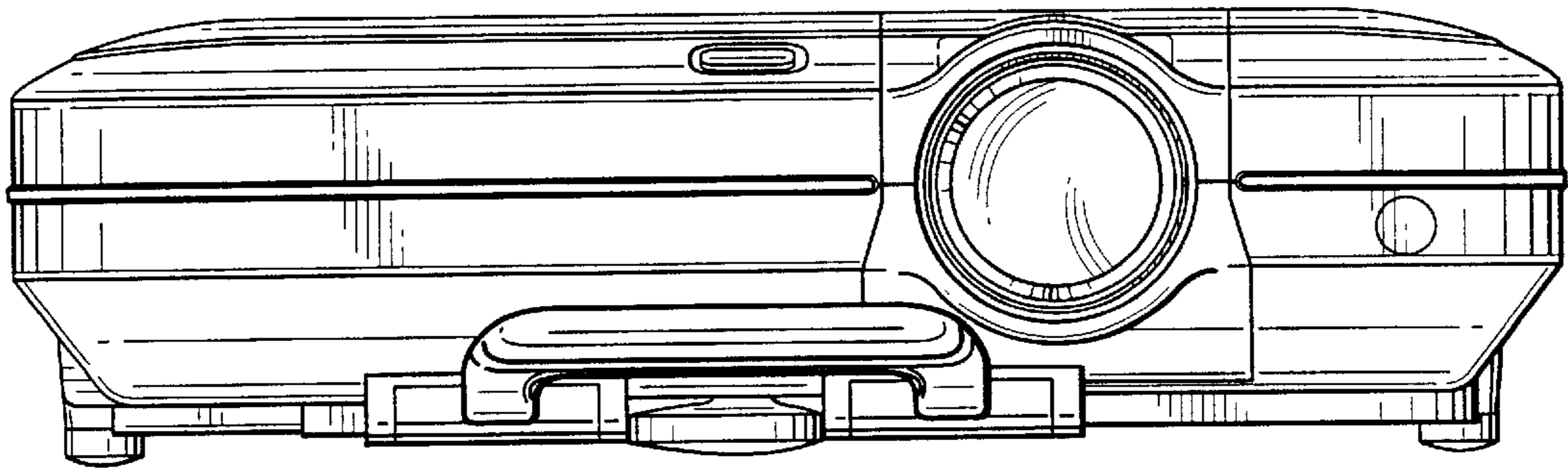
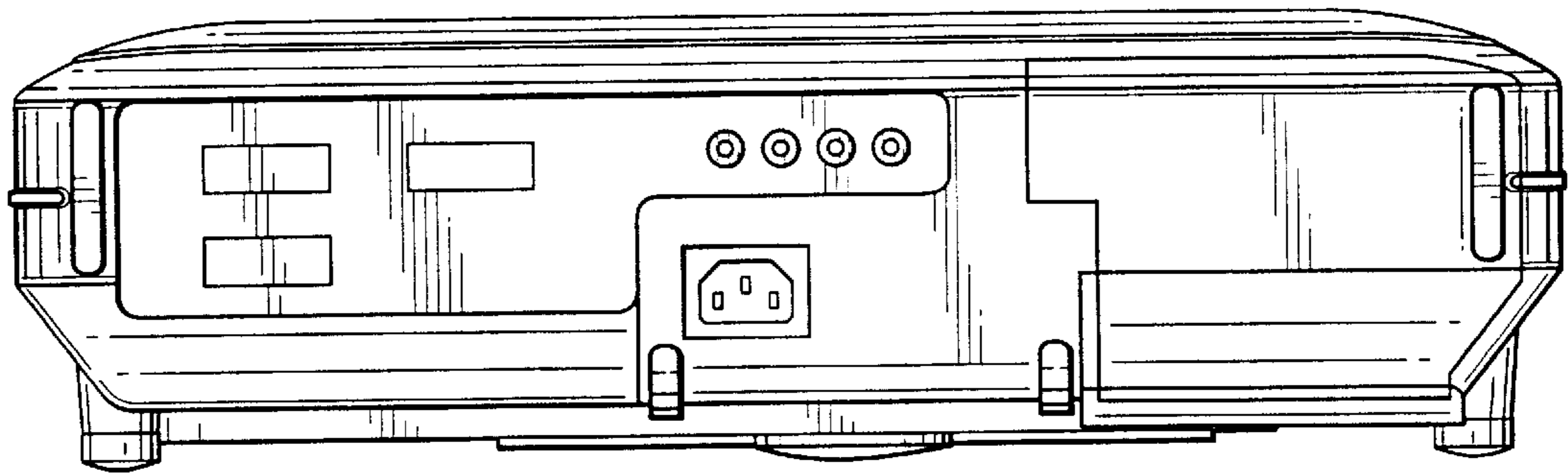

Fig. 1



*Fig. 2*



*Fig. 3*

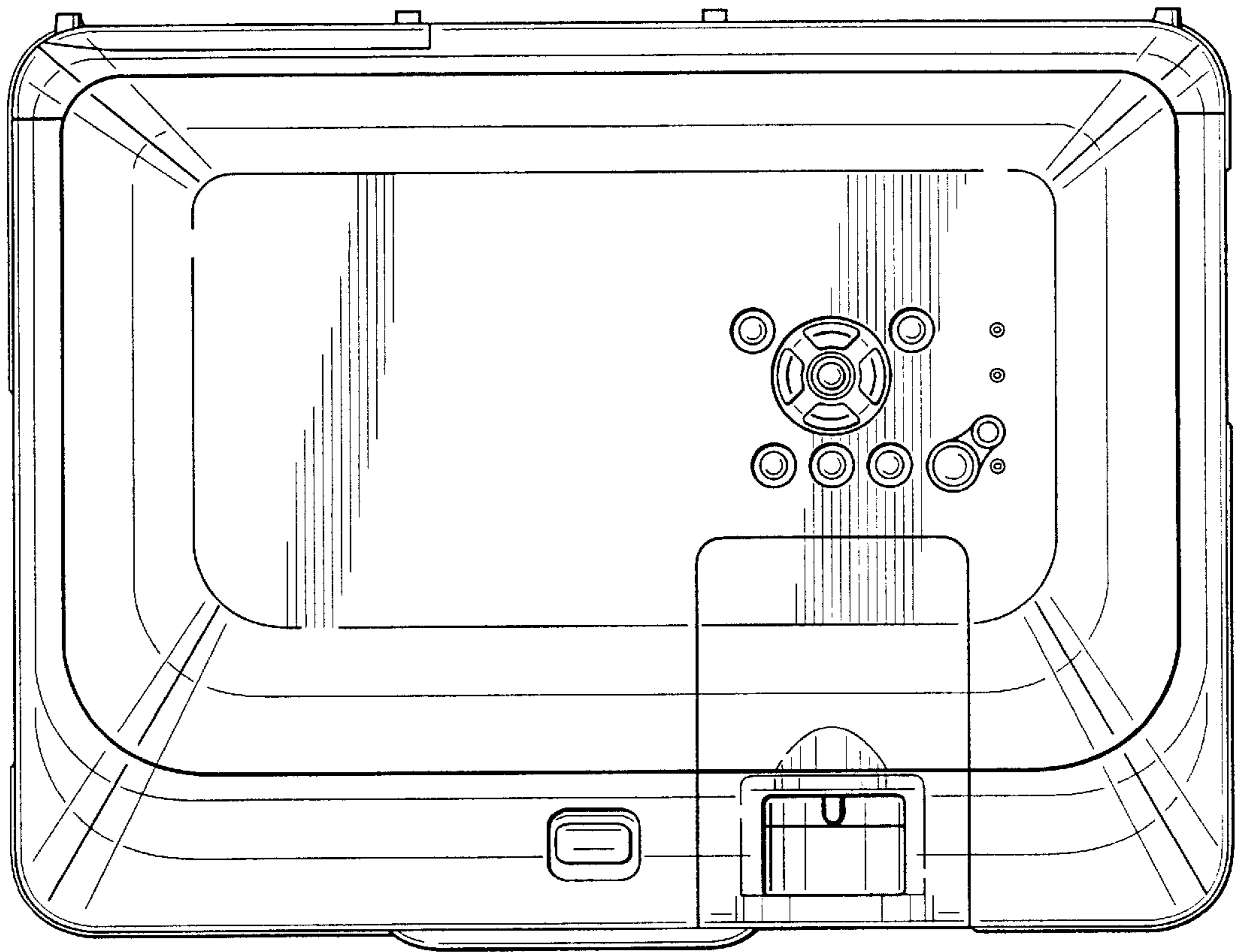

*Fig. 4*

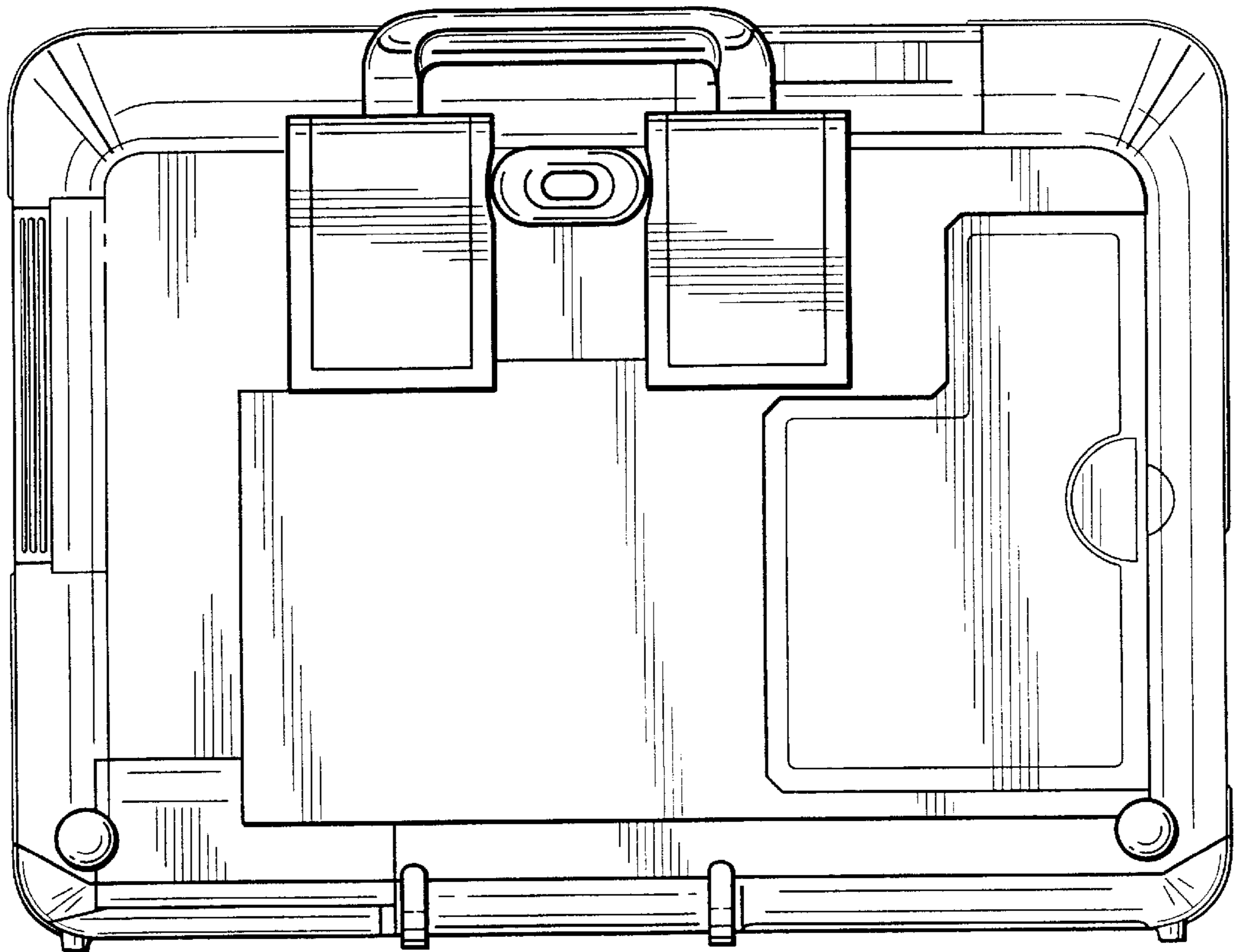

*Fig. 5*

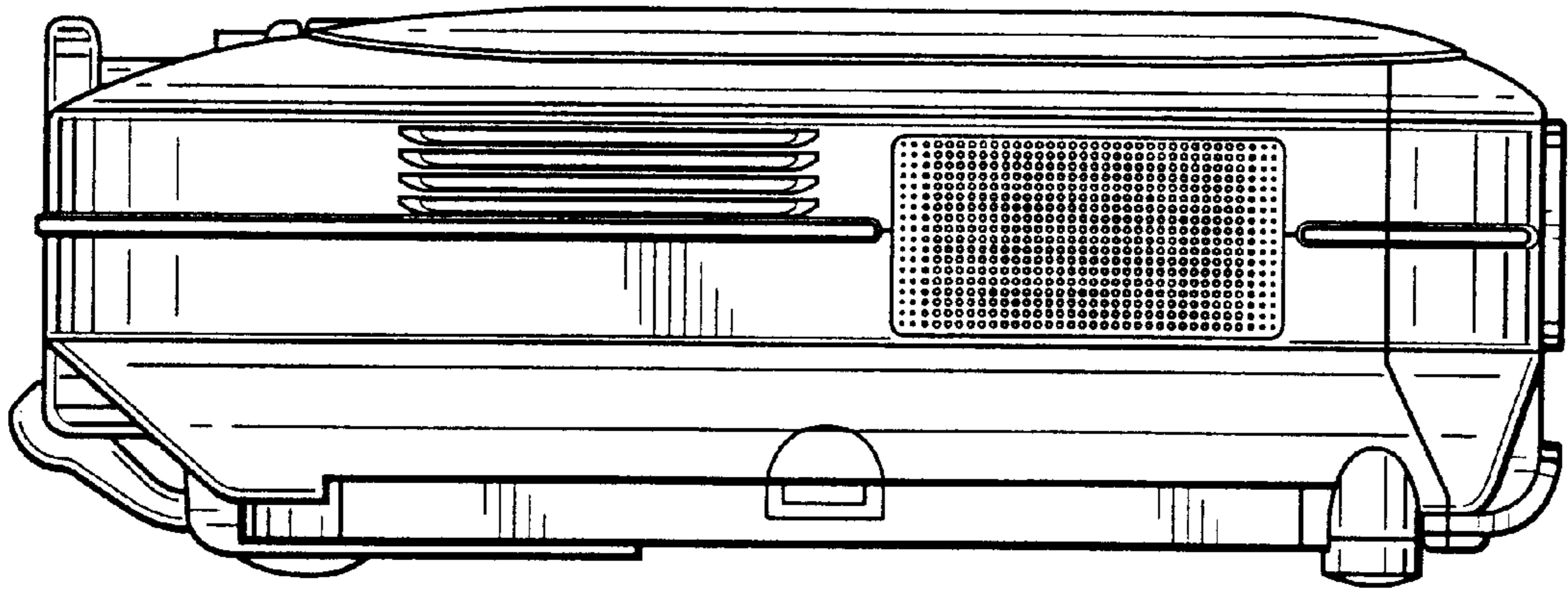

*Fig. 6*

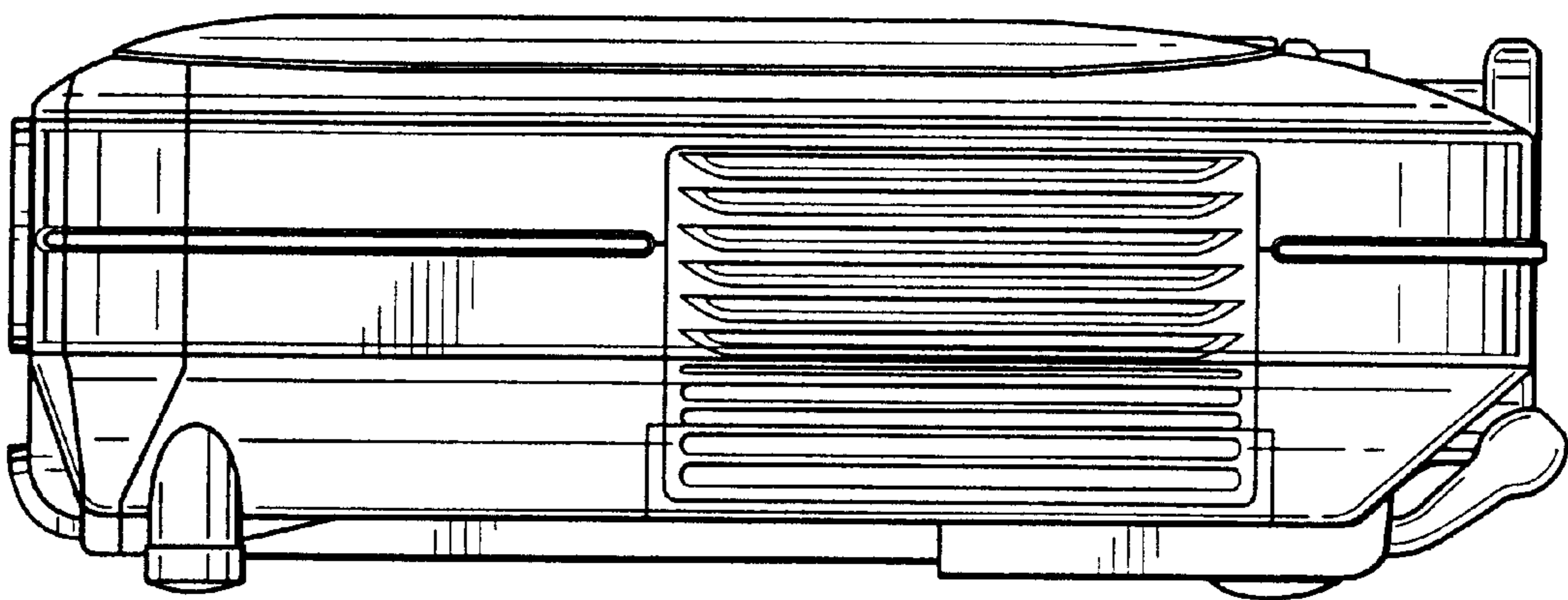

*Fig. 7*