



US00D472994S

(12) **United States Design Patent**
Horowitz

(10) **Patent No.:** **US D472,994 S**

(45) **Date of Patent:** **** Apr. 8, 2003**

(54) **TAIL LENS ASSEMBLY**

(75) Inventor: **Brian A. Horowitz**, Corona, CA (US)

(73) Assignee: **American Products Company, Inc.**,
Corona, CA (US)

(**) Term: **14 Years**

(21) Appl. No.: **29/162,735**

(22) Filed: **Jun. 19, 2002**

Related U.S. Application Data

(63) Continuation of application No. 29/155,850, filed on Feb. 14, 2002, now Pat. No. Des. 462,800.

(51) **LOC (7) Cl.** **26-04**

(52) **U.S. Cl.** **D26/28**

(58) **Field of Search** D26/28-36, 120,
D26/122; 362/61, 80, 81, 82, 83, 83.4,
267, 269, 275

(56) **References Cited**

U.S. PATENT DOCUMENTS

D382,659 S	8/1997	Kaloustian	
D388,200 S	12/1997	Tomforde et al.	
D439,995 S	4/2001	Nakazawa et al.	
D440,331 S	4/2001	Nakazawa et al.	
D442,713 S	5/2001	Janioka et al.	
6,243,008 B1	6/2001	Korabiak	
D448,098 S	9/2001	Horowitz	
D448,869 S	10/2001	Horowitz	
D449,123 S	10/2001	Horowitz	
D449,898 S	10/2001	Horowitz	
6,296,382 B1	10/2001	Hamelbeck	
D450,142 S	11/2001	Horowitz	
D450,403 S	11/2001	Sacco et al.	
D462,800 S	* 9/2002	Horowitz D26/28

OTHER PUBLICATIONS

Photograph of stock Ford Expedition ('97 -).
Photograph of stock Lincoln Navigator ('98 -).
American Products Company Y2K Catalog p. 8-9 (published Oct. 21, 1999).

American Products Company 2001 Catalog p. 10-13 (published Oct. 10, 2000).
Hiper Industries 2002 Catalog, p. 4 (prior to Jan. 1, 2002).
in.pro.carwear Catalog, p. 18 (prior to Jan. 1, 2002).
Legaparts Brochure, p. 4 (prior to Jan. 1, 2002).
Z2000 Brochure, p. 4 (prior to Jan. 1, 2002).
Promotional material from Sigma Polyurethane International (prior to Jul. 25, 2001).
Toucan Industries 2001 Catalog, p. 25 (prior to Oct. 30, 2000).
Stillen and from Sport Compact Car, vol. 13, No. 3, Mar. 2001.
CaliforniaStylin.com ad from Mini Trucking, Nov. 2001.

* cited by examiner

Primary Examiner—Marcus A. Jackson

(74) *Attorney, Agent, or Firm*—Knobbe, Martens, Olson & Bear, LLP

(57) **CLAIM**

The ornamental design for a tail lens assembly, as shown and described.

DESCRIPTION

FIG. 1 is a front-right perspective view of a preferred embodiment of the tail lens assembly according to the present invention;
FIG. 2 is a partially exploded front-right perspective view of the tail lens assembly of FIG. 1, illustrating the cover of the tail lens assembly removed;
FIG. 3 is a front elevational view of the tail lens assembly of FIG. 1;
FIG. 4 is a right-side elevational view of the tail lens assembly of FIG. 1;
FIG. 5 is a top plan view of the tail lens assembly of FIG. 1;
FIG. 6 is a front-right perspective view of the tail lens assembly of FIG. 1, illustrating the tail lens assembly installed on a vehicle;
FIG. 7 is a front-right perspective view of another preferred embodiment of the tail lens assembly according to the present invention;

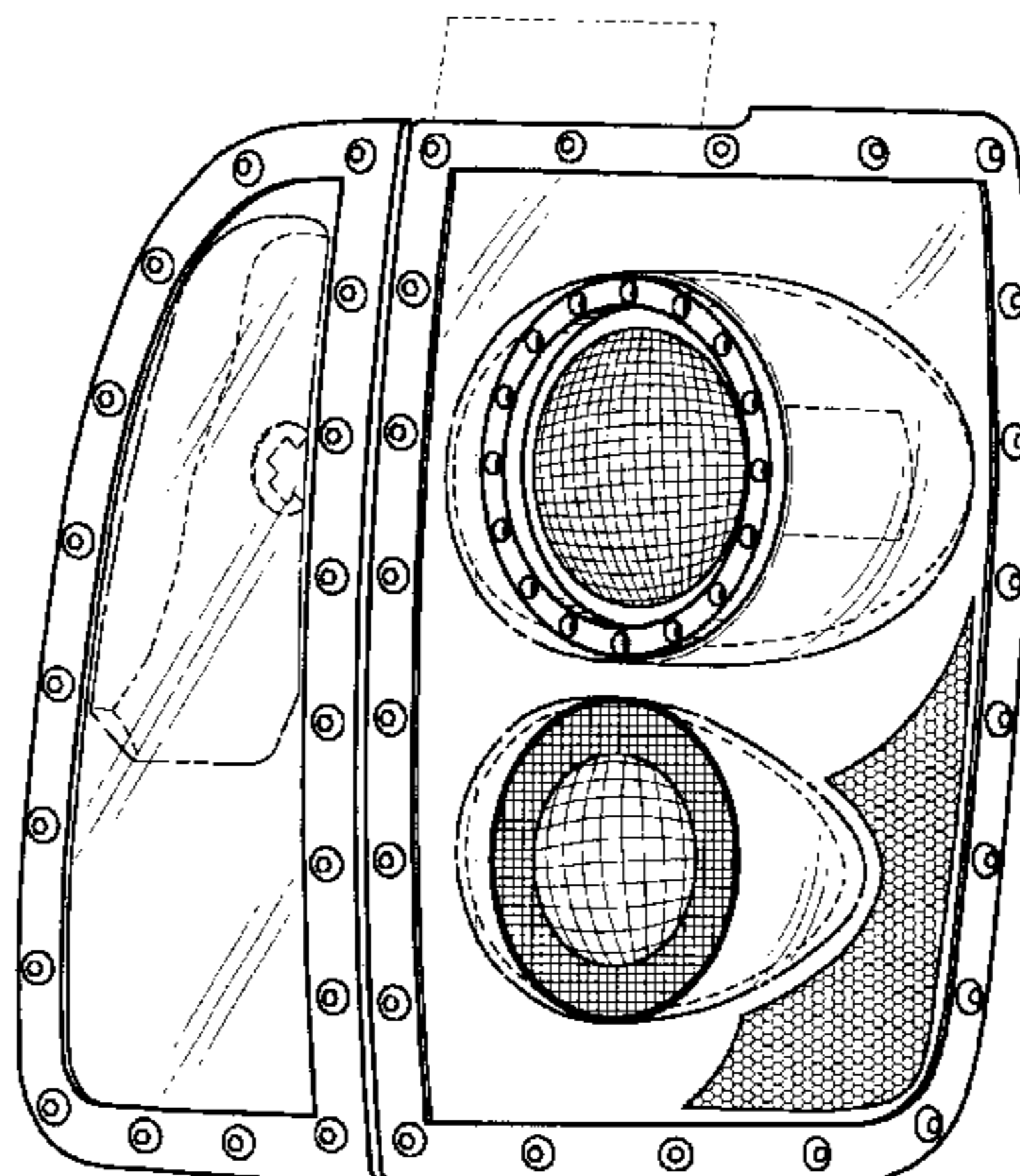

FIG. 8 is a partially exploded front-right perspective view of the tail lens assembly of FIG. 7, illustrating the cover of the tail lens assembly removed;

FIG. 9 is a front elevational view of the tail lens assembly of FIG. 7;

FIG. 10 is a right-side elevational view of the tail lens assembly of FIG. 7;

FIG. 11 is a top plan view of the tail lens assembly of FIG. 7;

FIG. 12 is a front-right perspective view of the tail lens assembly of FIG. 7, illustrating the tail lens assembly installed on a vehicle;

FIG. 13 is a front-right perspective view of another preferred embodiment of the tail lens assembly according to the present invention;

FIG. 14 is a partially exploded front-right perspective view of the tail lens assembly of FIG. 13, illustrating the cover of the tail lens assembly removed;

FIG. 15 is a front elevational view of the tail lens assembly of FIG. 13;

FIG. 16 is a right-side elevational view of the tail lens assembly of FIG. 13;

FIG. 17 is a top plan view of the tail lens assembly of FIG. 13;

FIG. 18 is a front-right perspective view of the tail lens assembly of FIG. 13, illustrating the tail lens assembly installed on a vehicle;

FIG. 19 is a front-right perspective view of another preferred embodiment of the tail lens assembly according to the present invention;

FIG. 20 is a partially exploded front-right perspective view of the tail lens assembly of FIG. 19, illustrating the cover of the tail lens assembly removed;

FIG. 21 is a front elevational view of the tail lens assembly of FIG. 19;

FIG. 22 is a right-side elevational view of the tail lens assembly of FIG. 19;

FIG. 23 is a top plan view of the tail lens assembly of FIG. 19; and,

FIG. 24 is a front-right perspective view of the tail lens assembly of FIG. 19, illustrating the tail lens assembly installed on a vehicle.

Phantom lining, where used, is for illustrative purposes only and is not intended to limit the claimed design to the features shown in phantom.

1 Claim, 16 Drawing Sheets

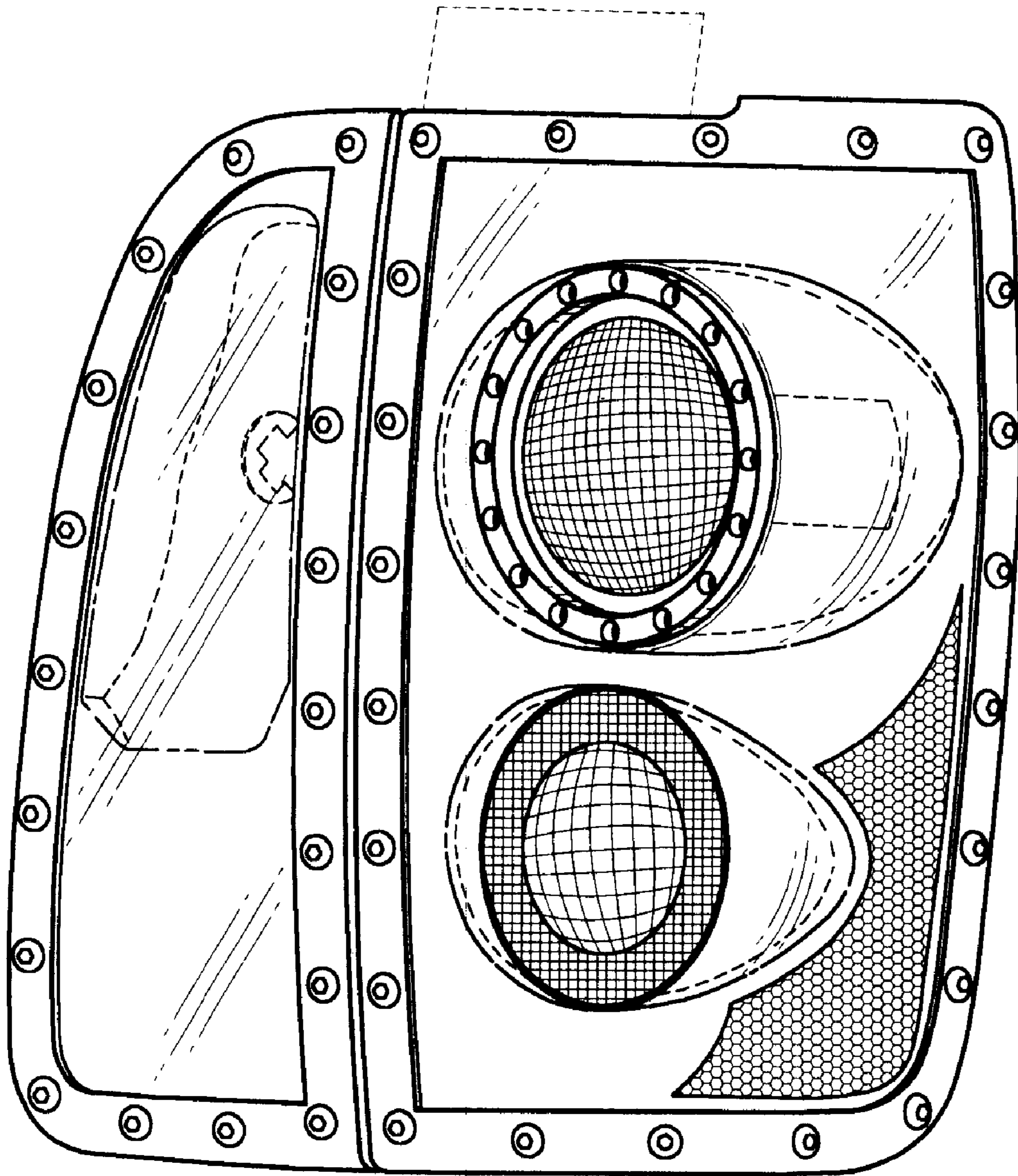

FIG. 1

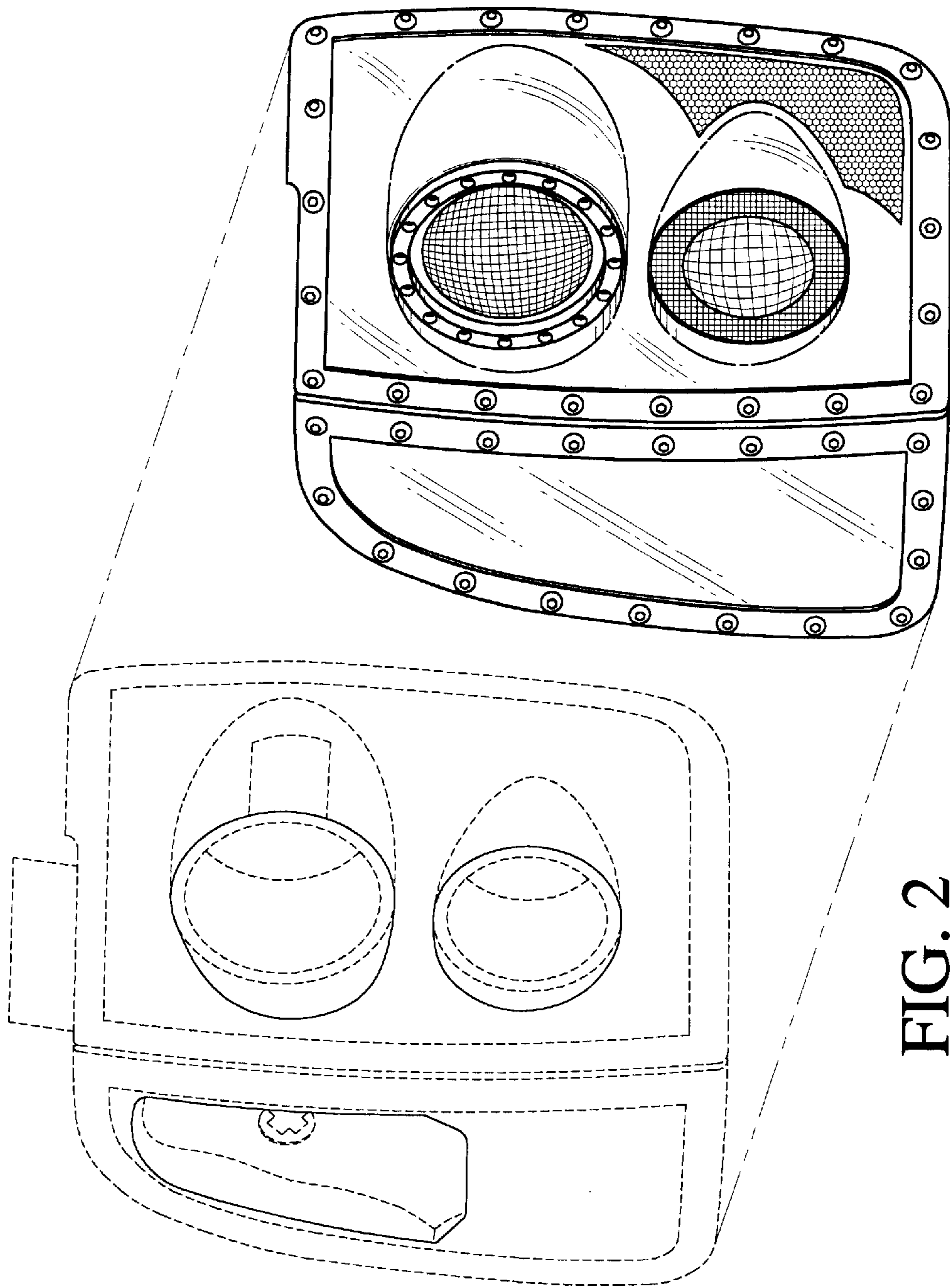

FIG. 2

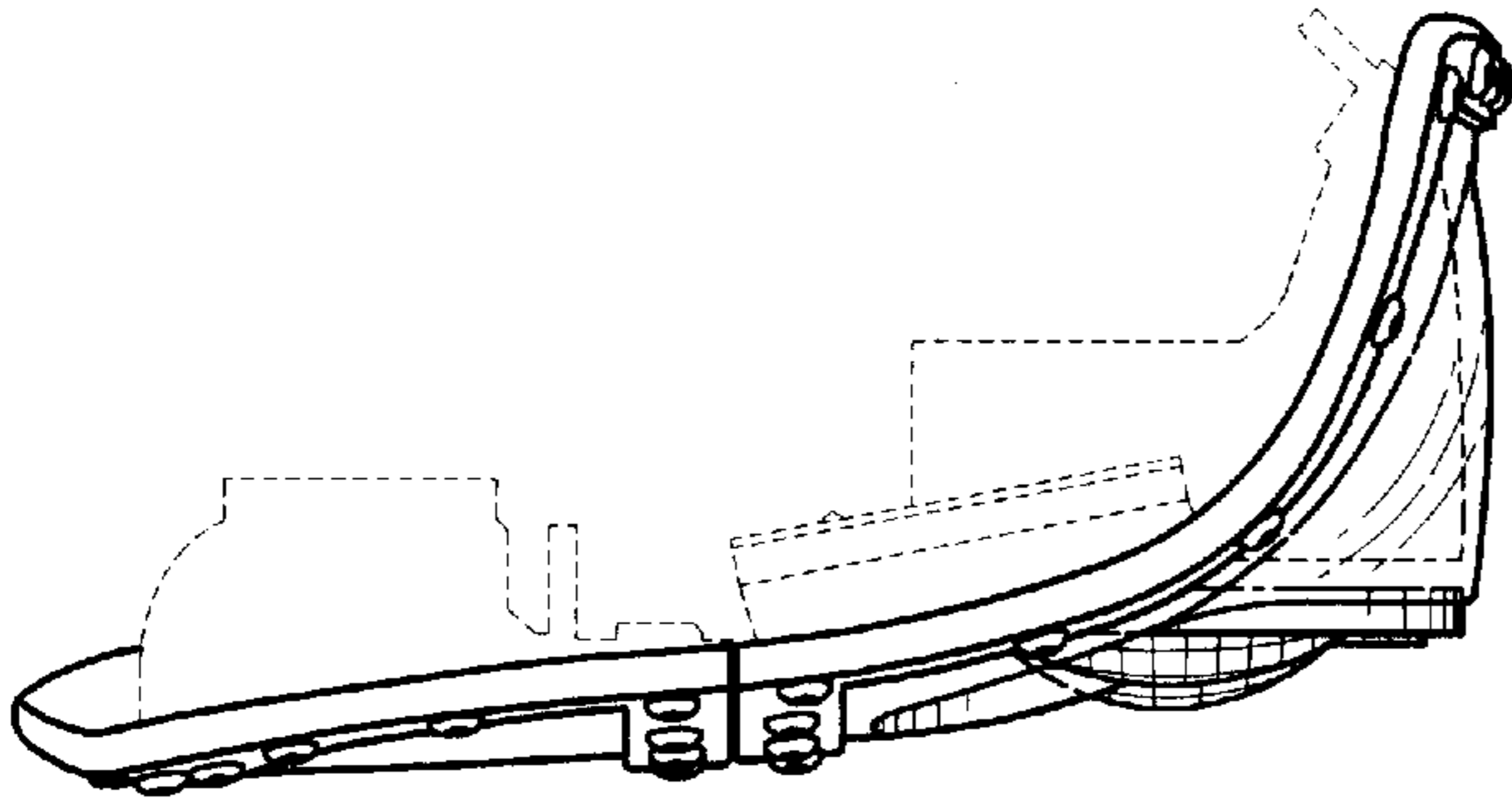

FIG. 5

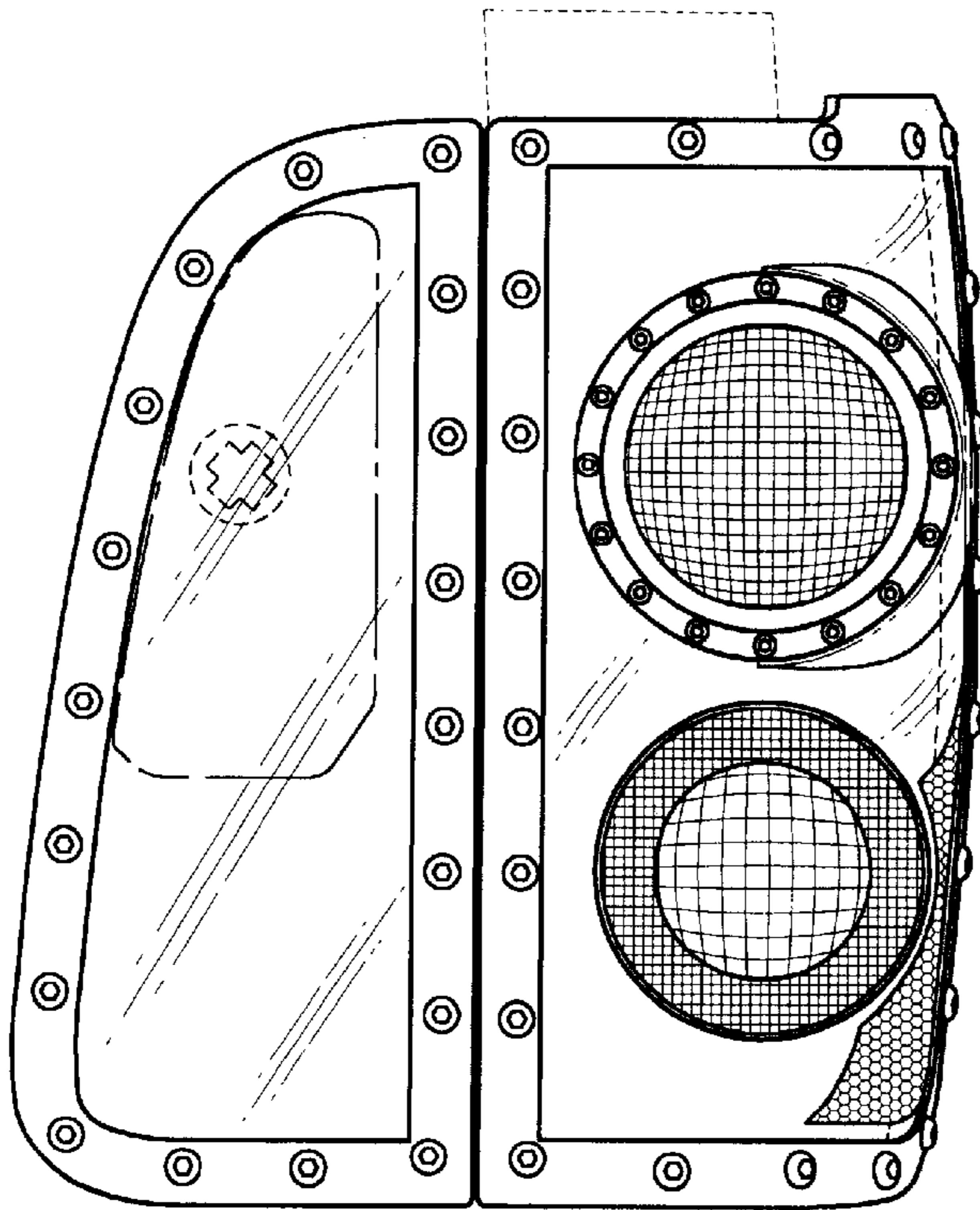

FIG. 3

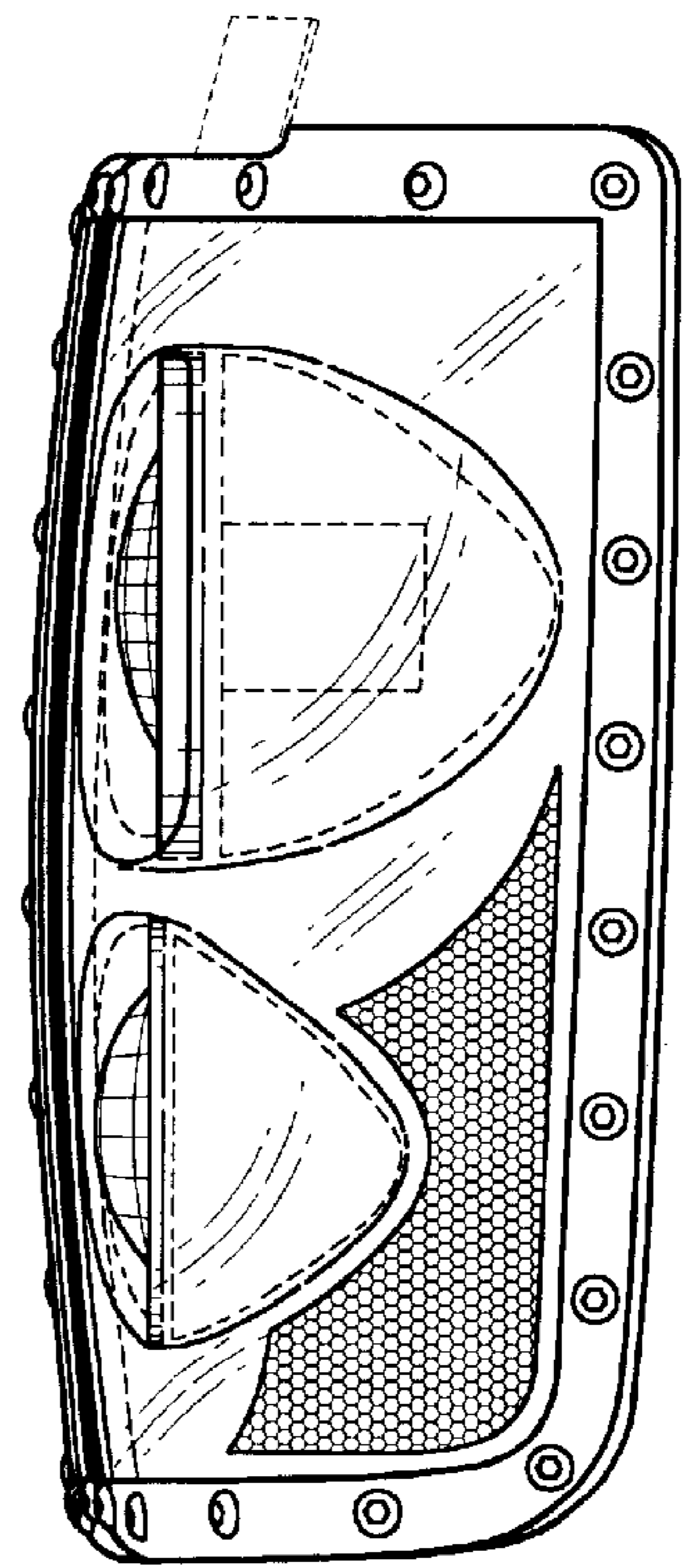

FIG. 4

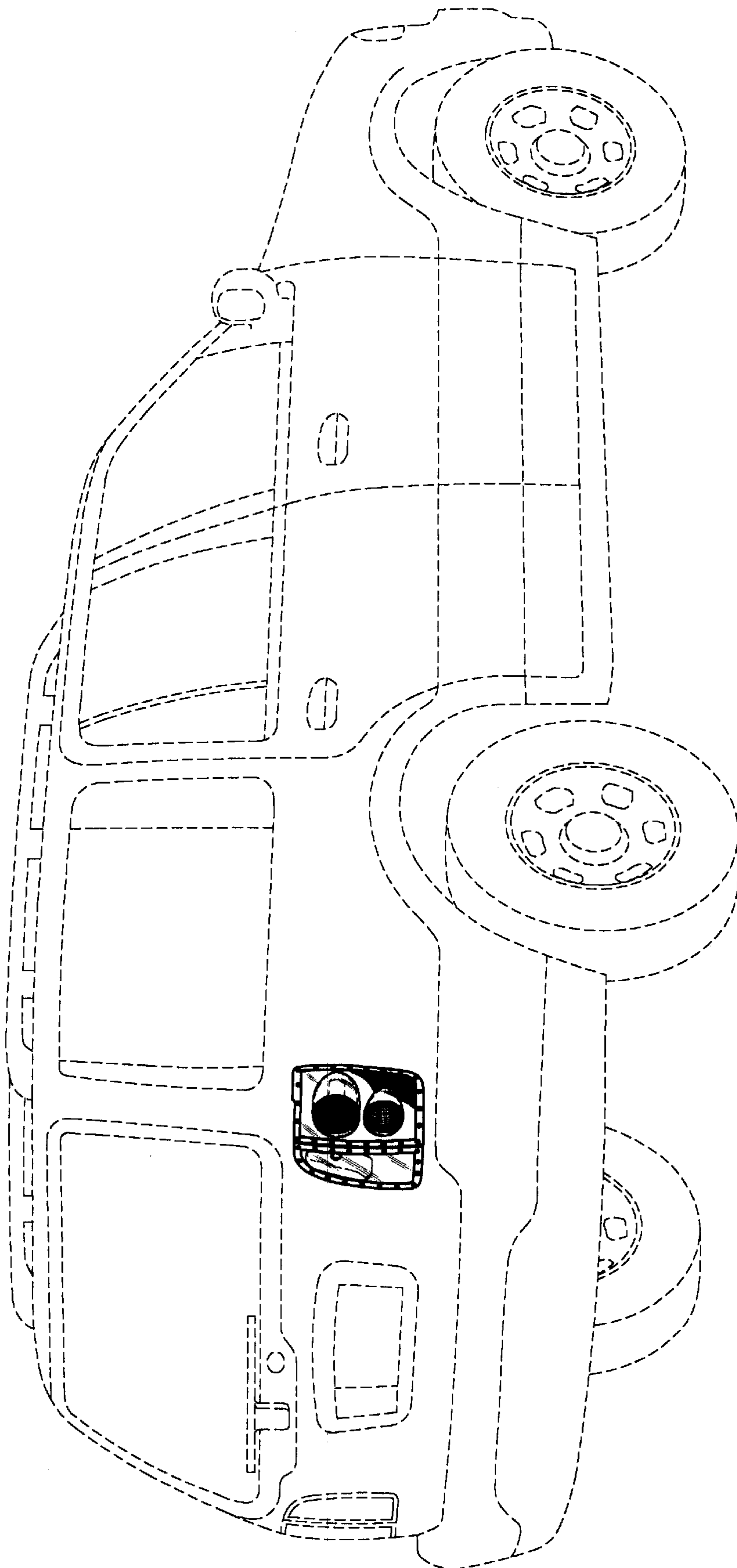

FIG. 6

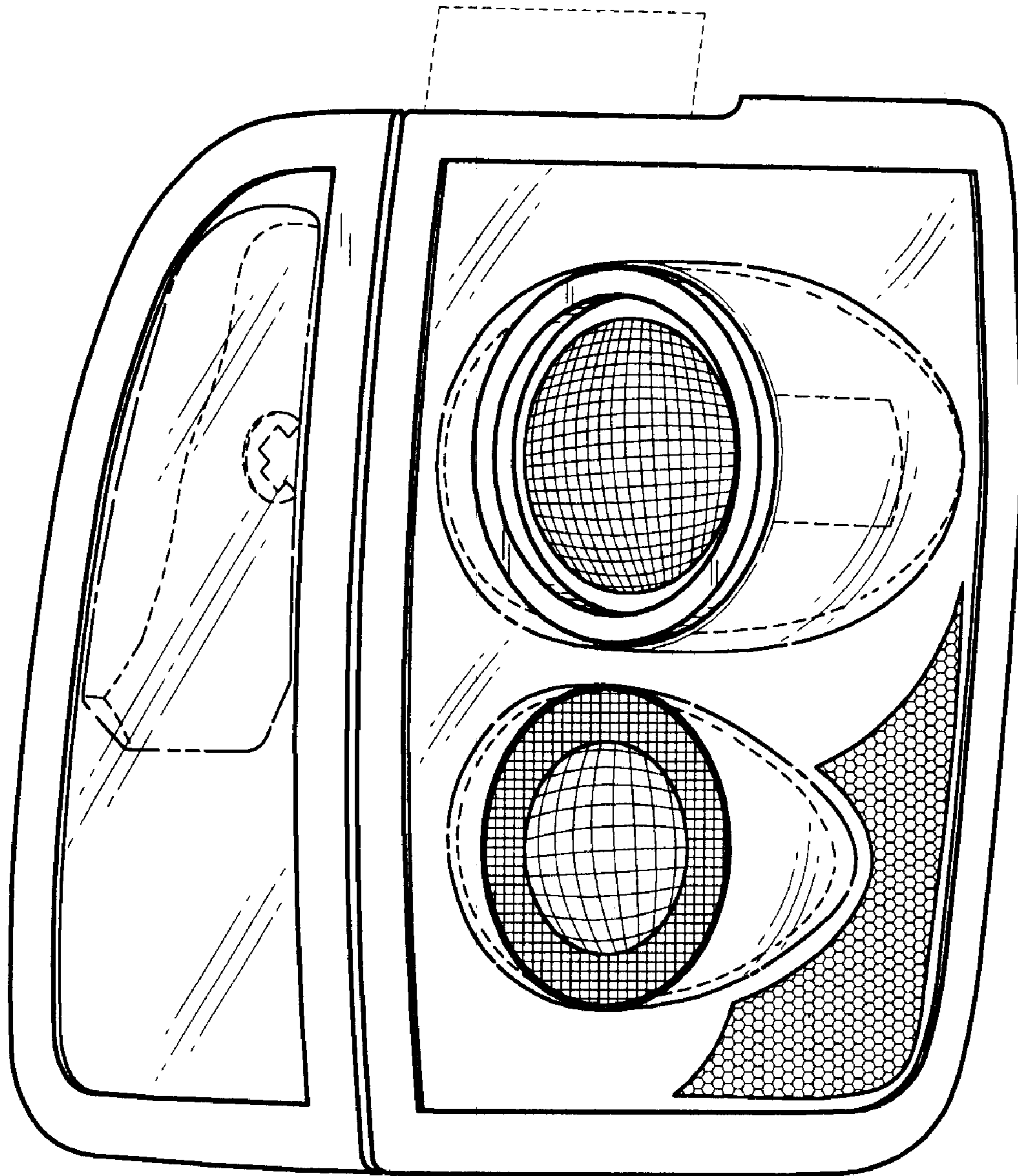

FIG. 7

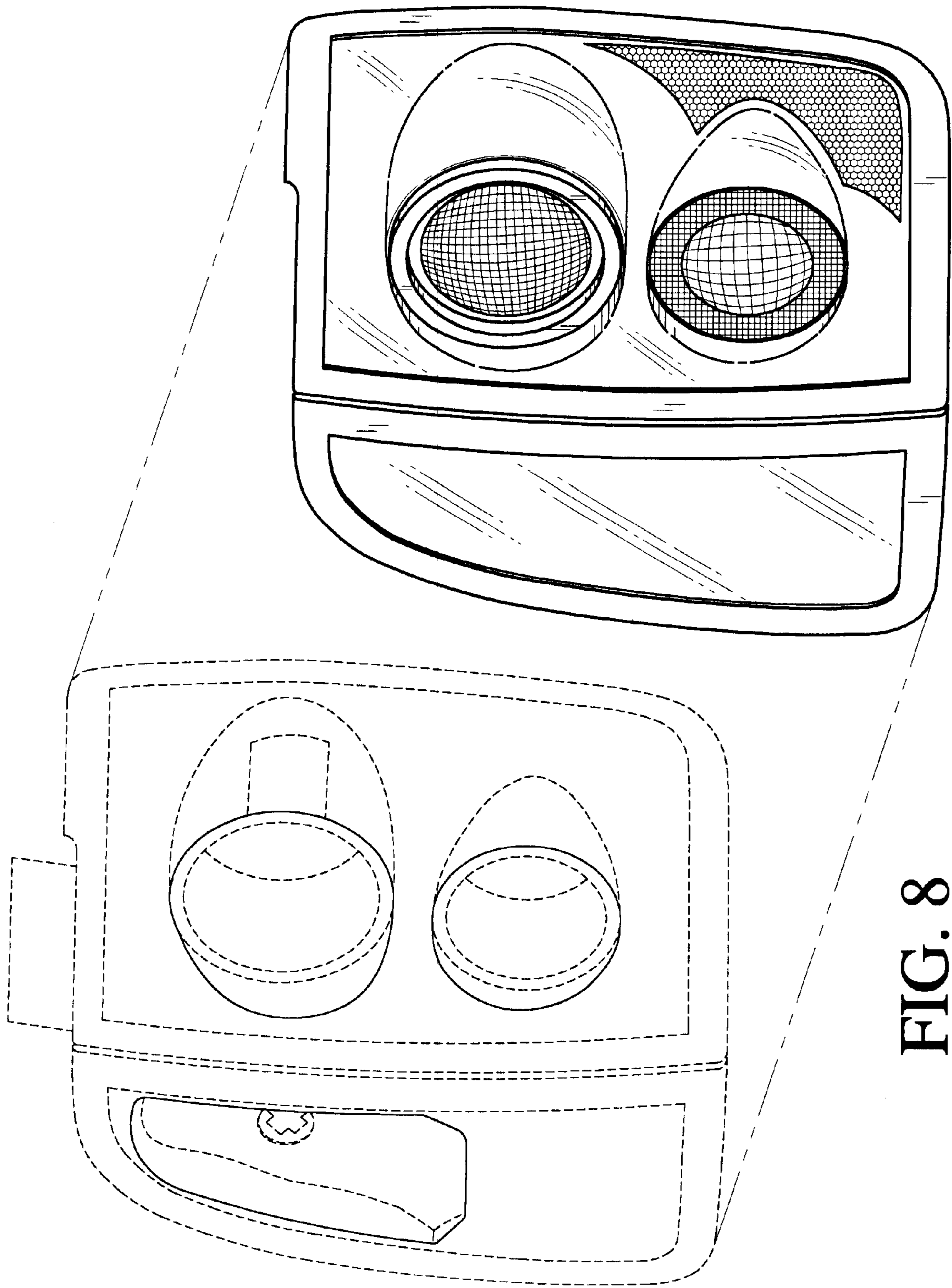

FIG. 8

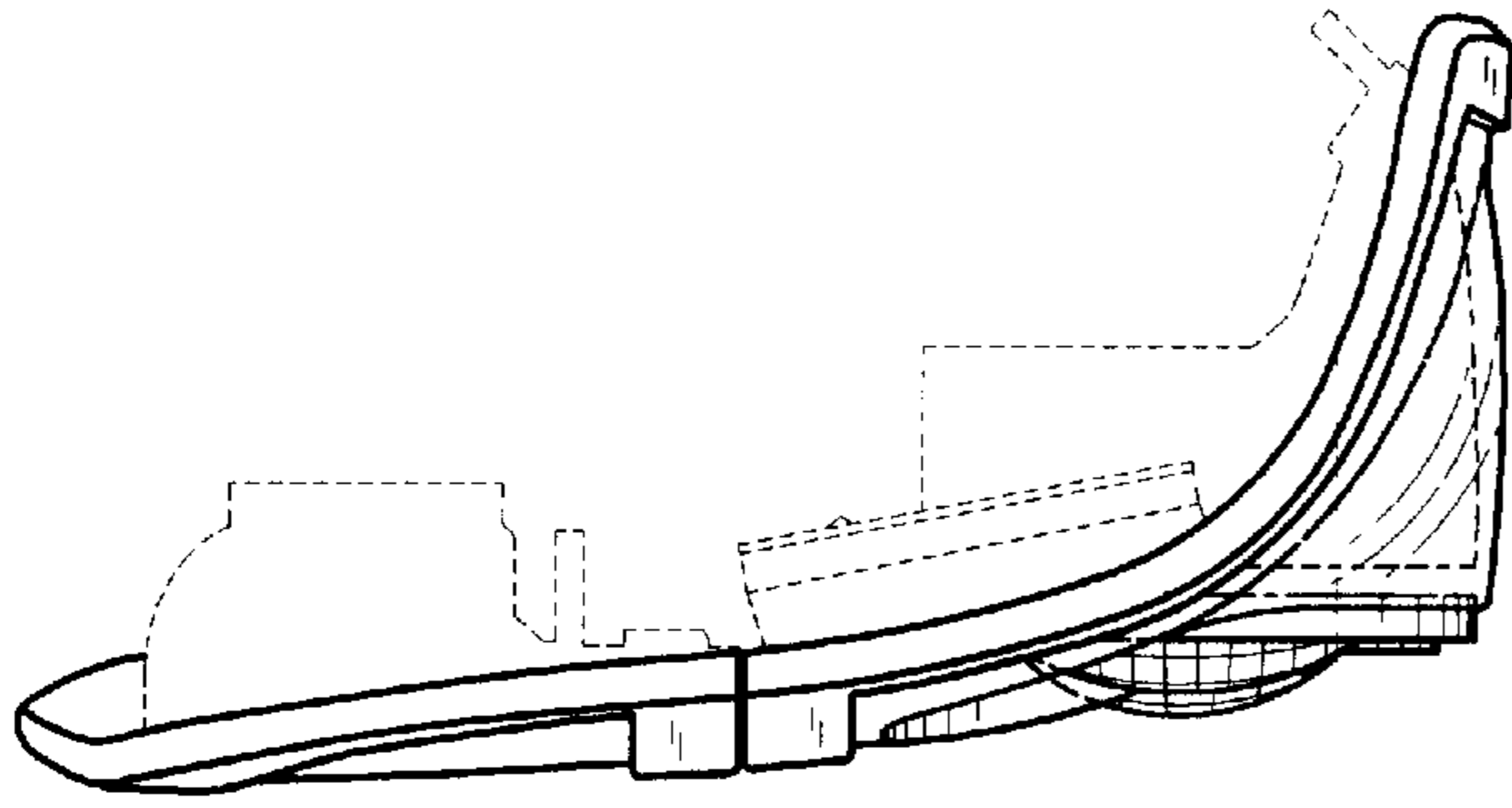

FIG. 11

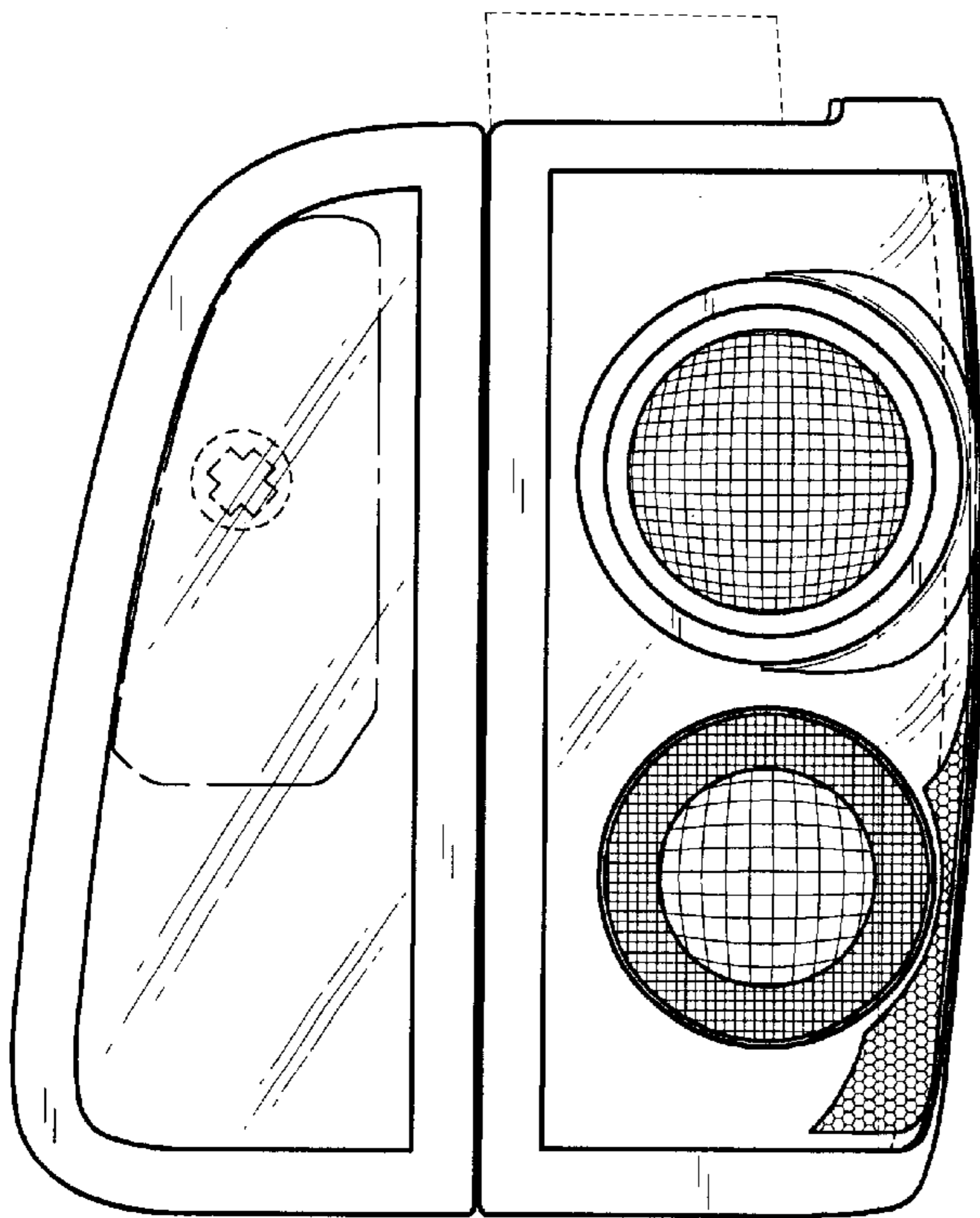

FIG. 9

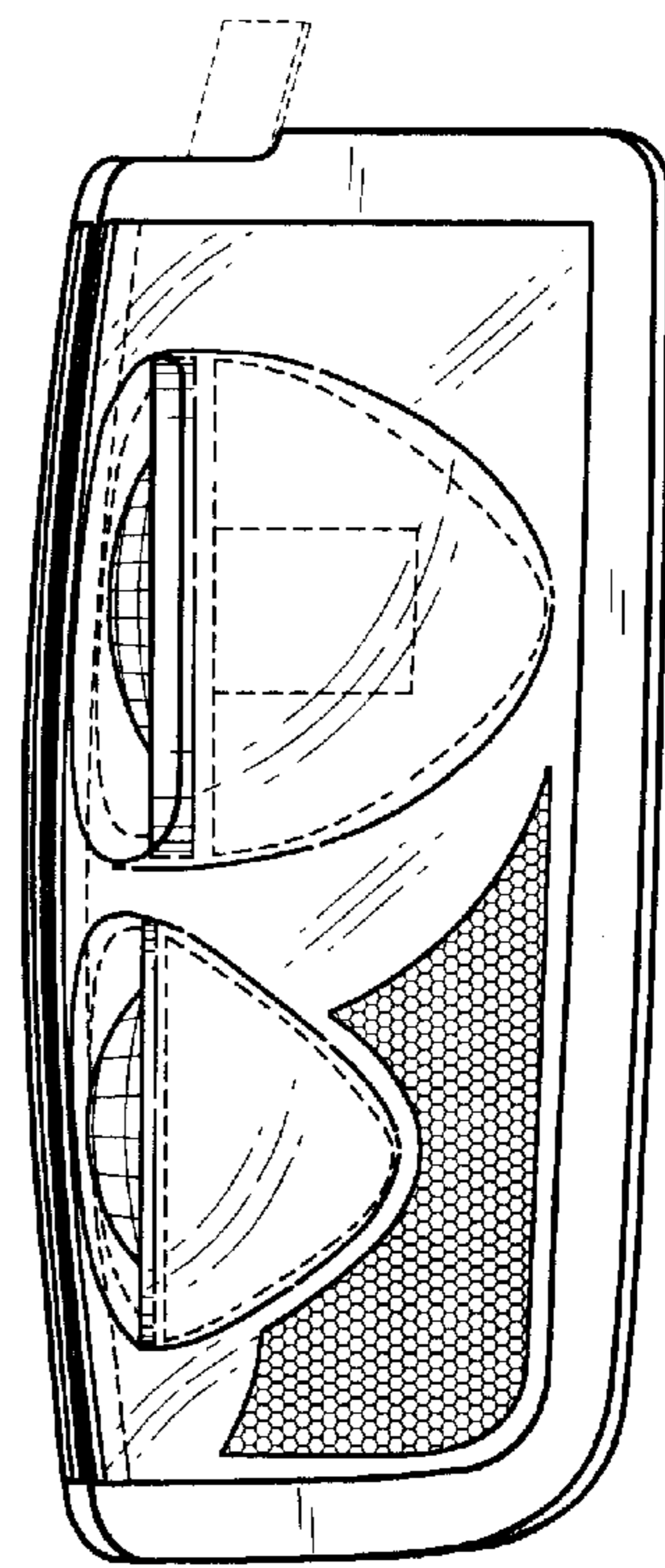

FIG. 10

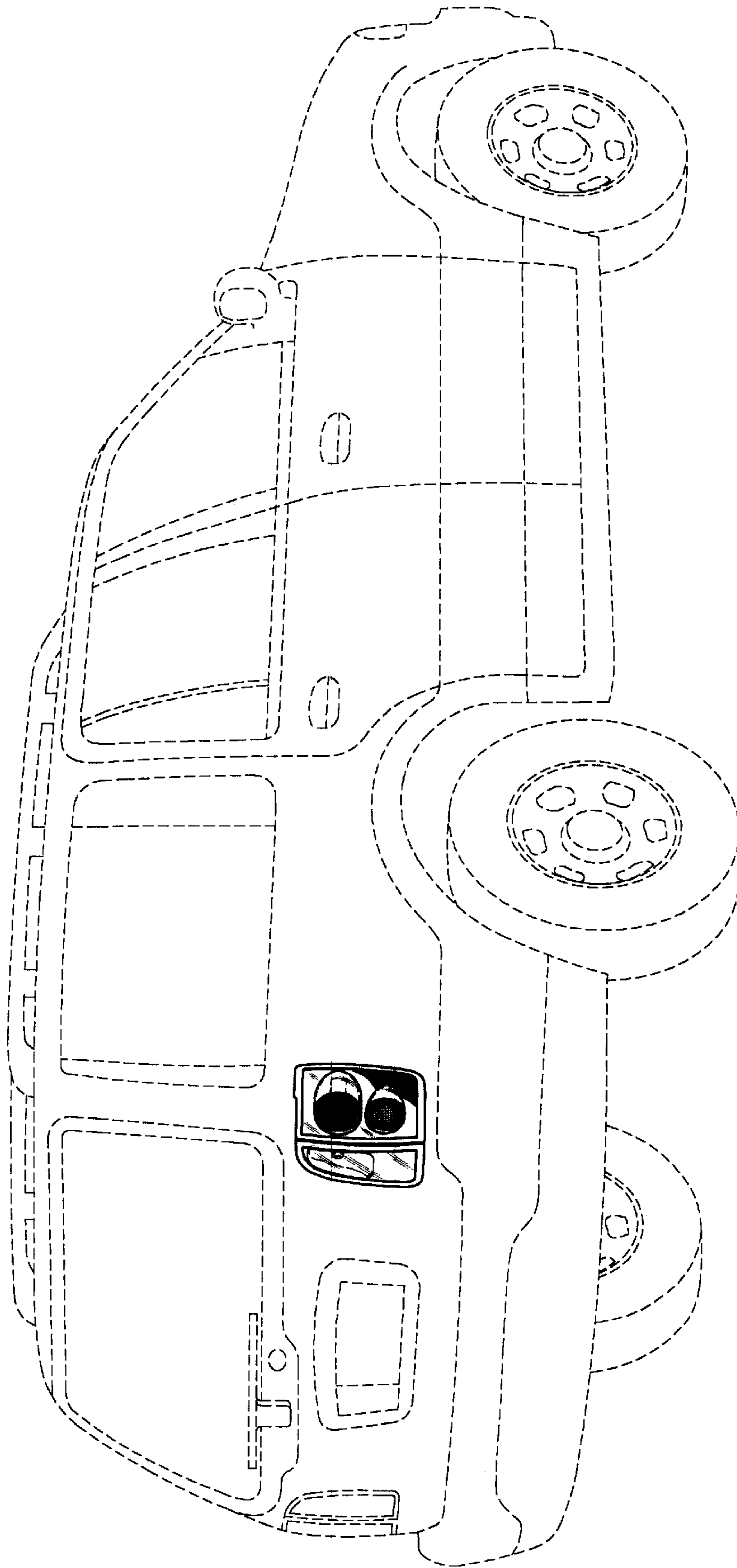

FIG. 12

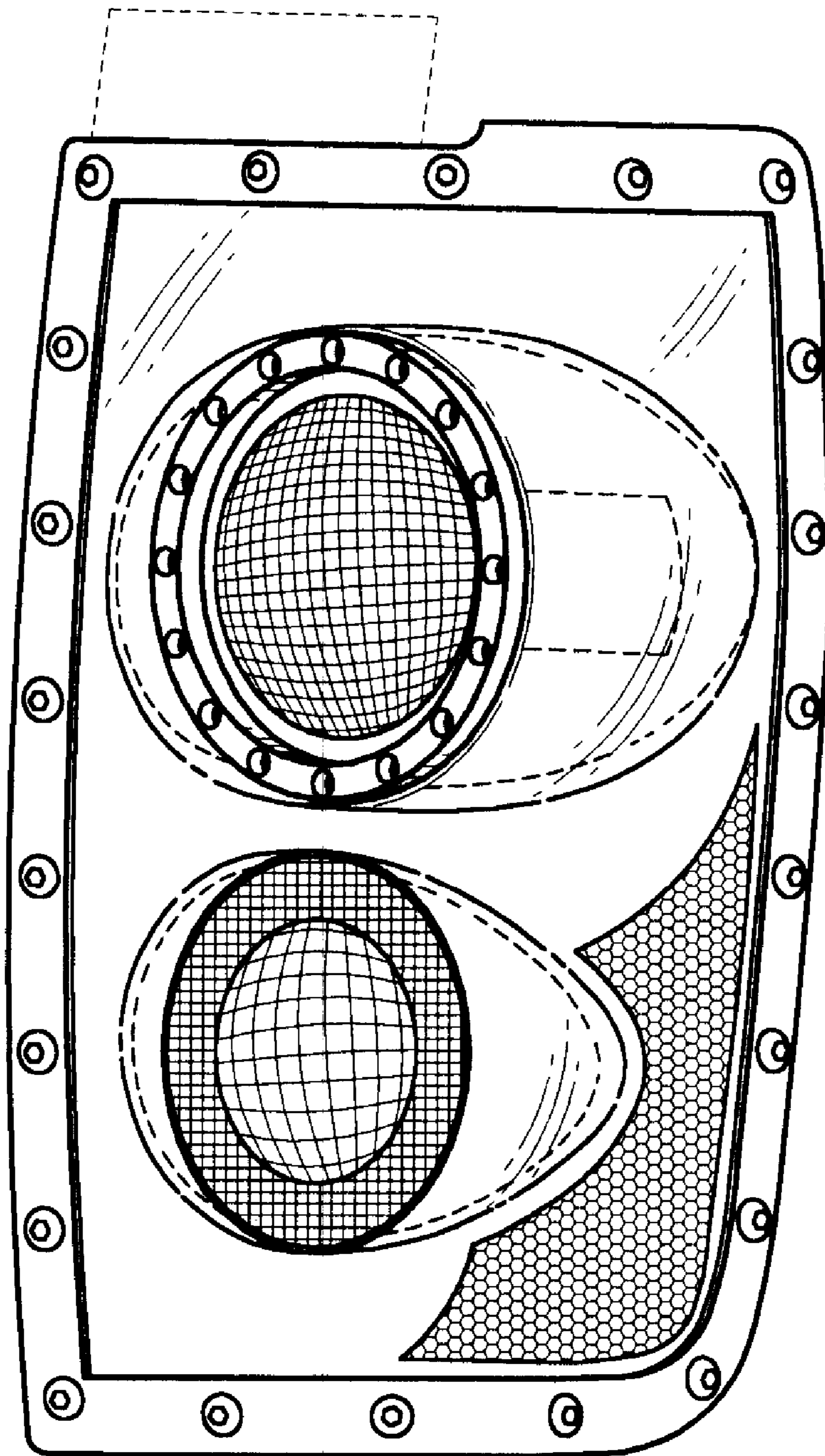

FIG. 13

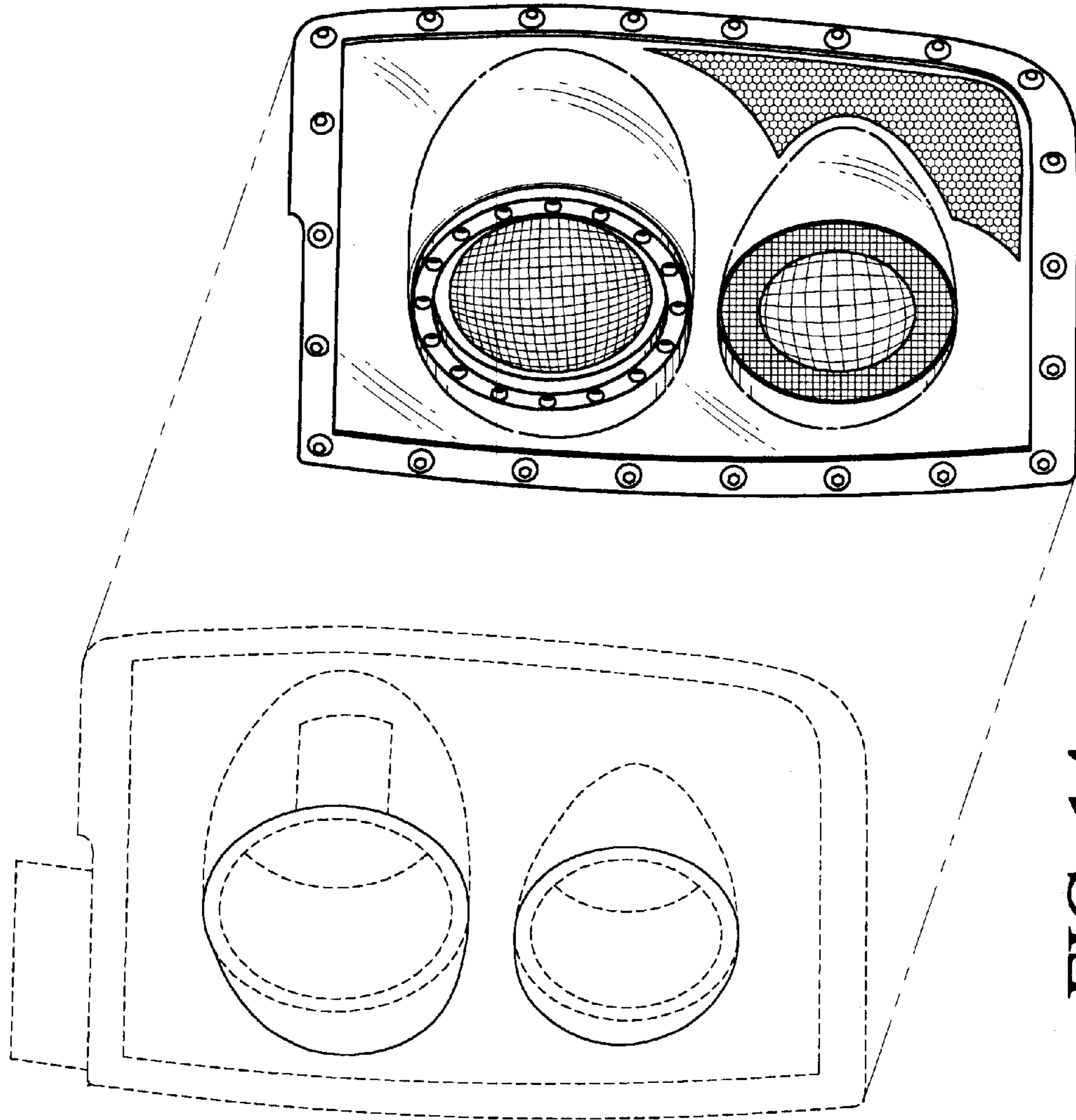

FIG. 14

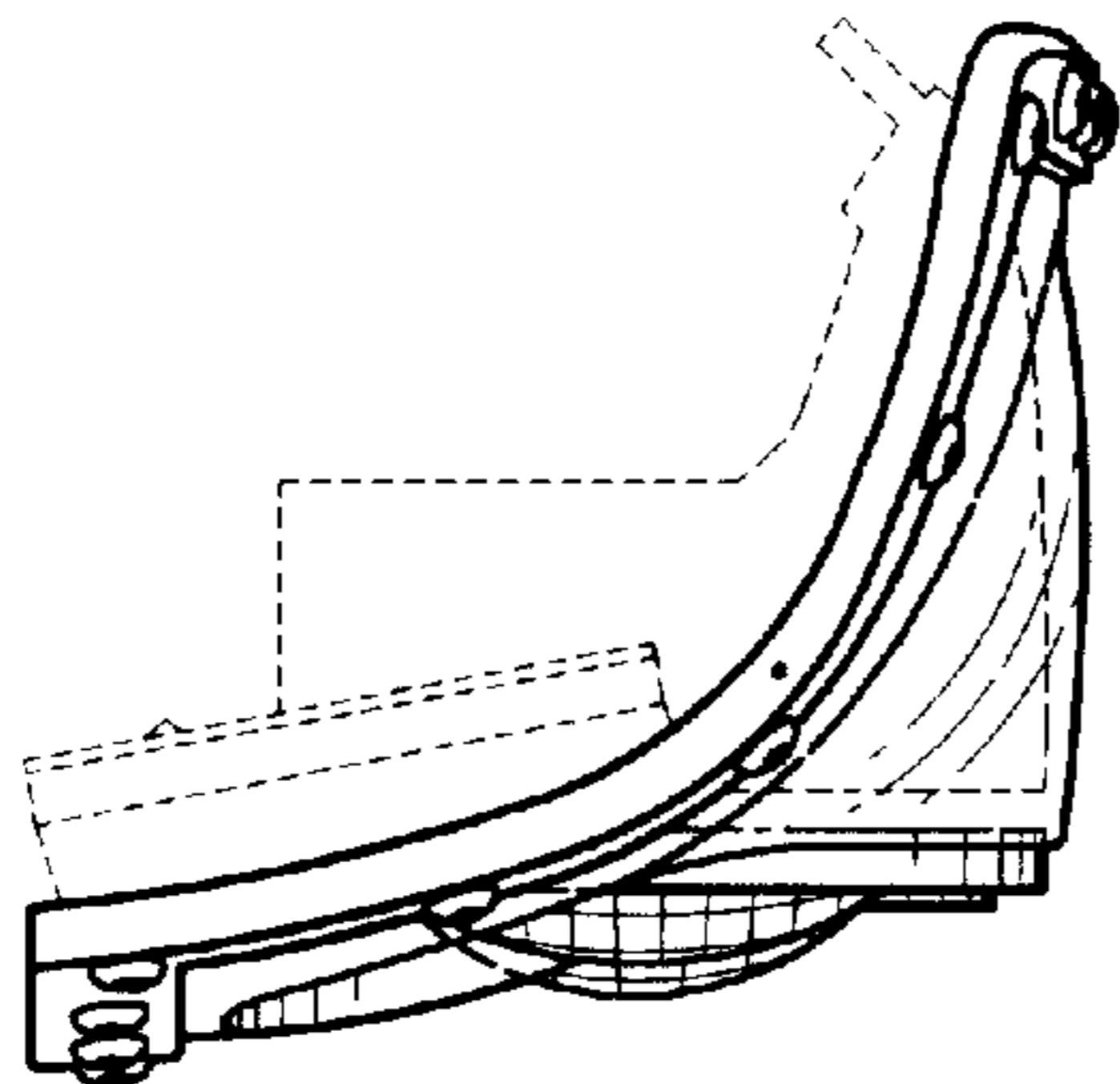

FIG. 17

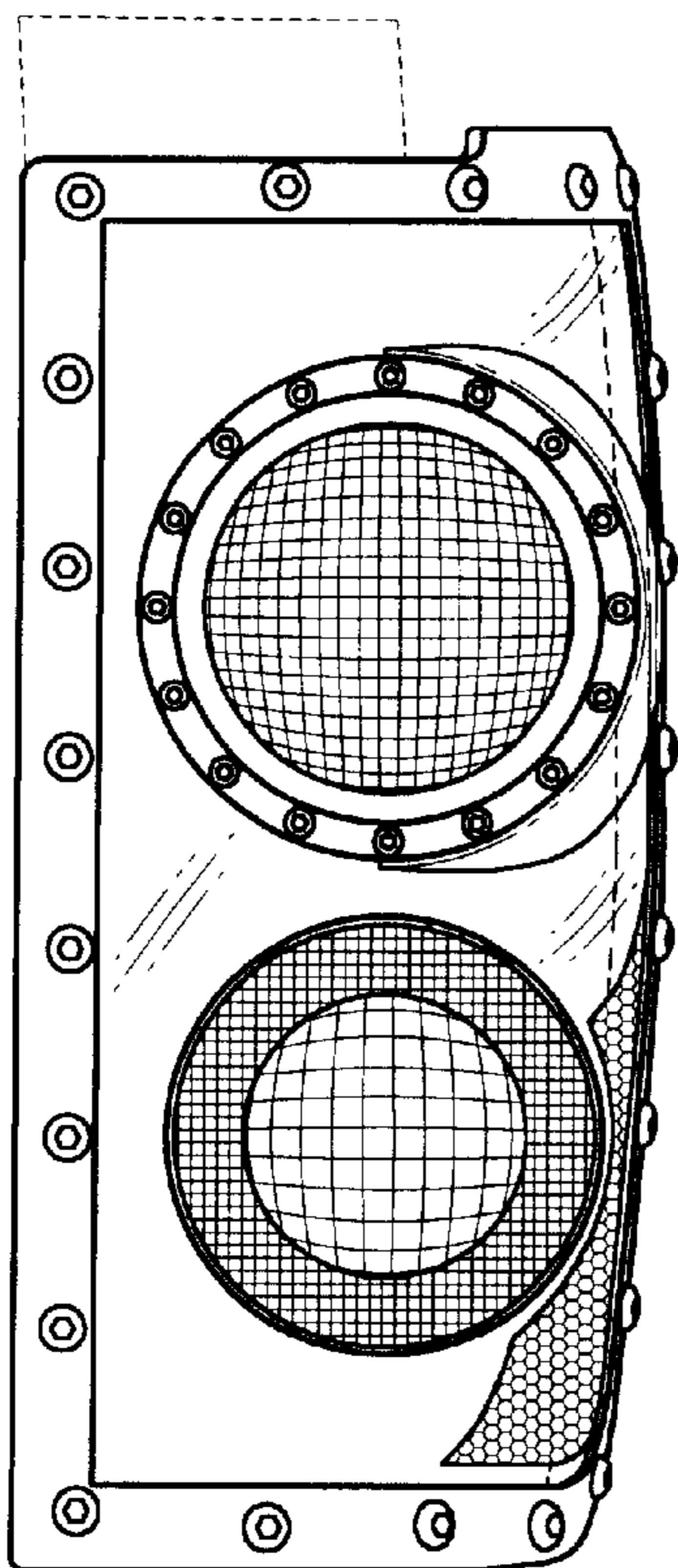

FIG. 15

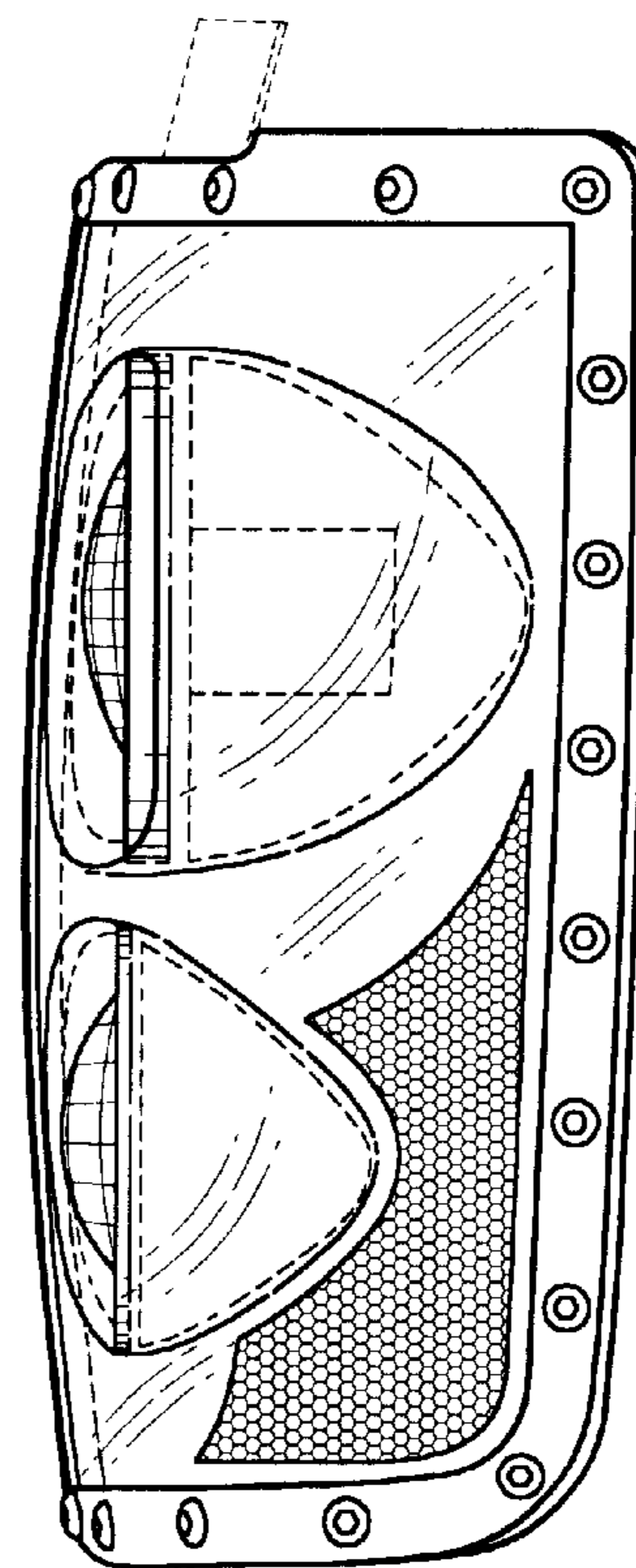

FIG. 16

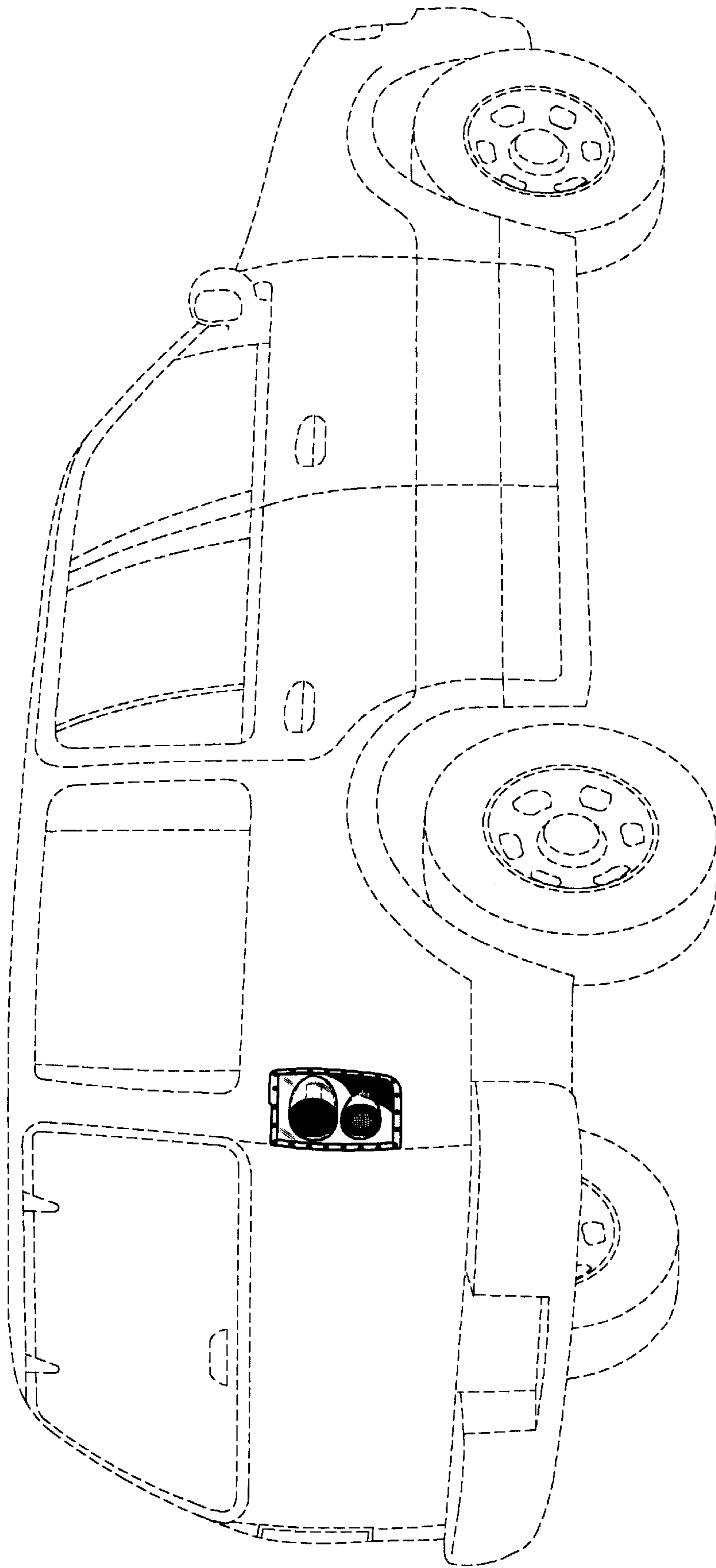

FIG. 18

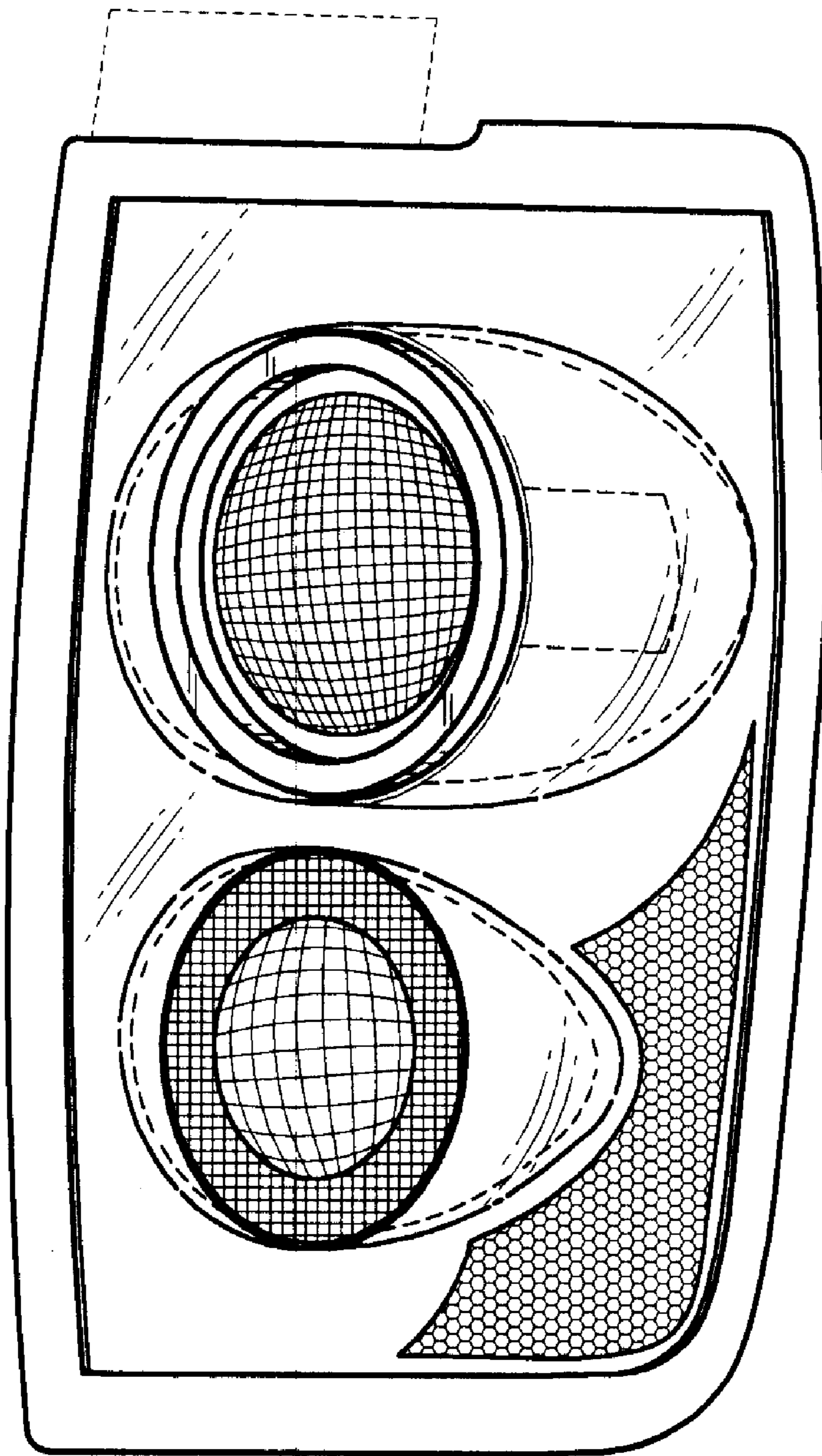

FIG. 19

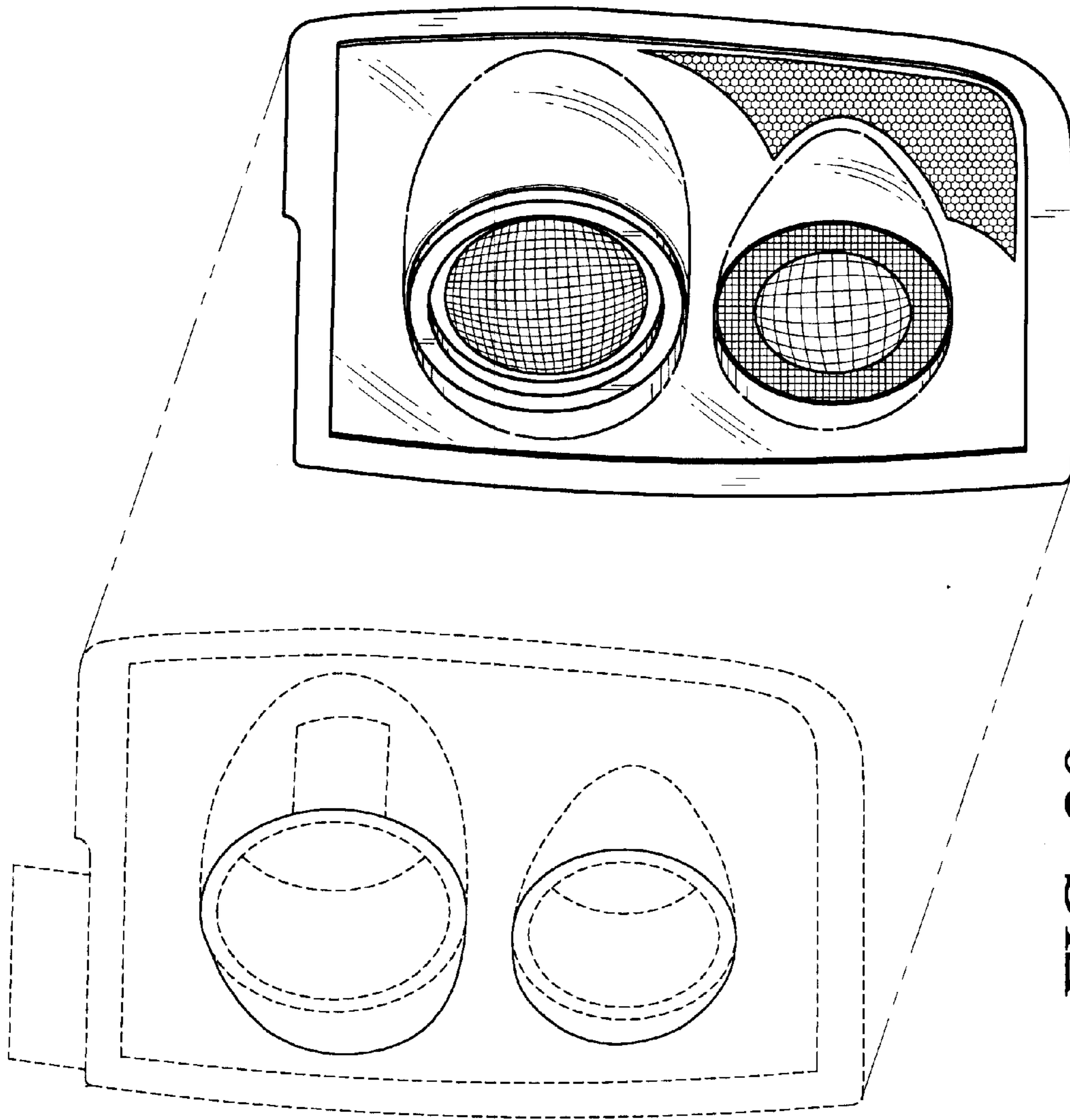

FIG. 20

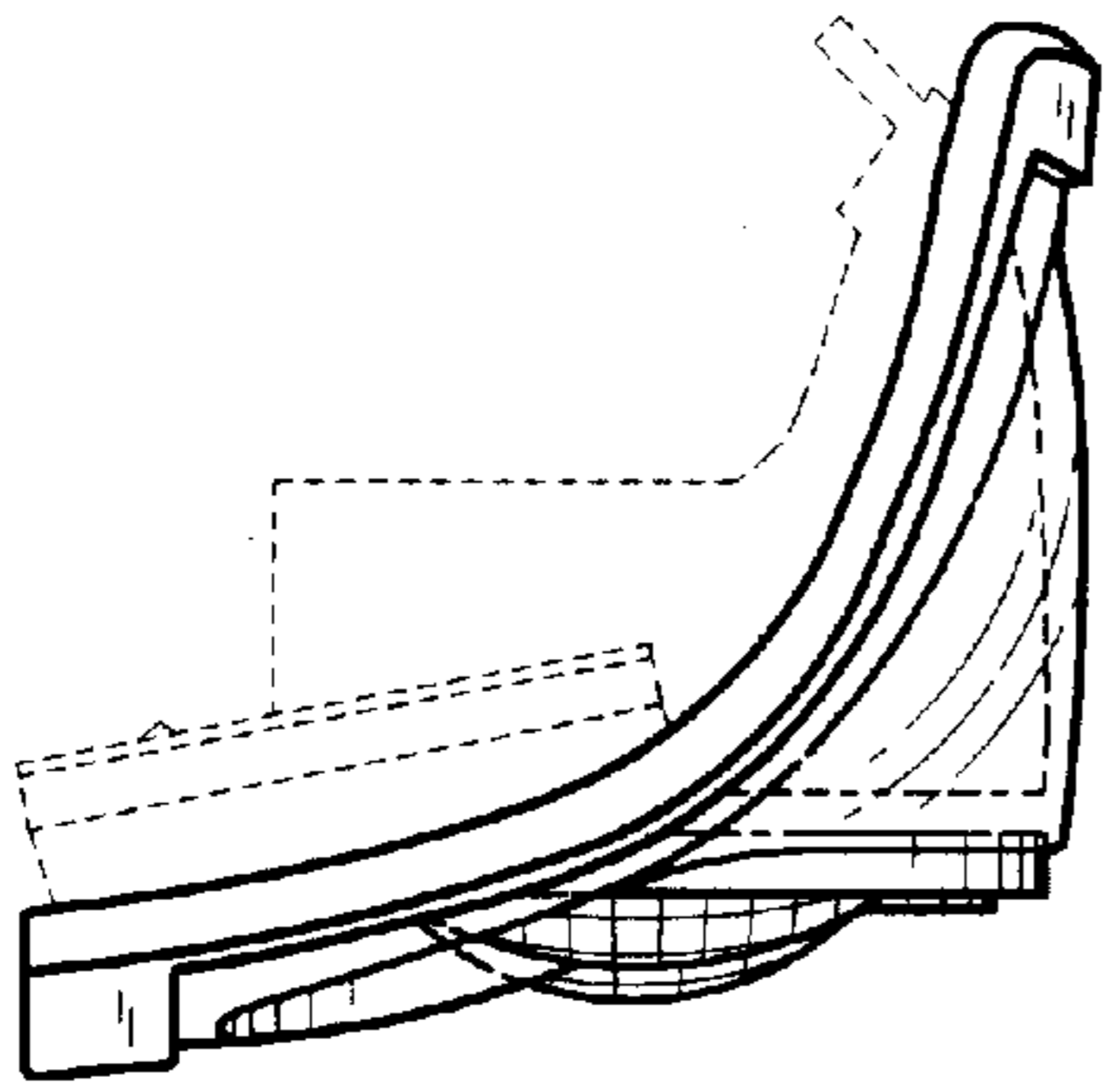

FIG. 23

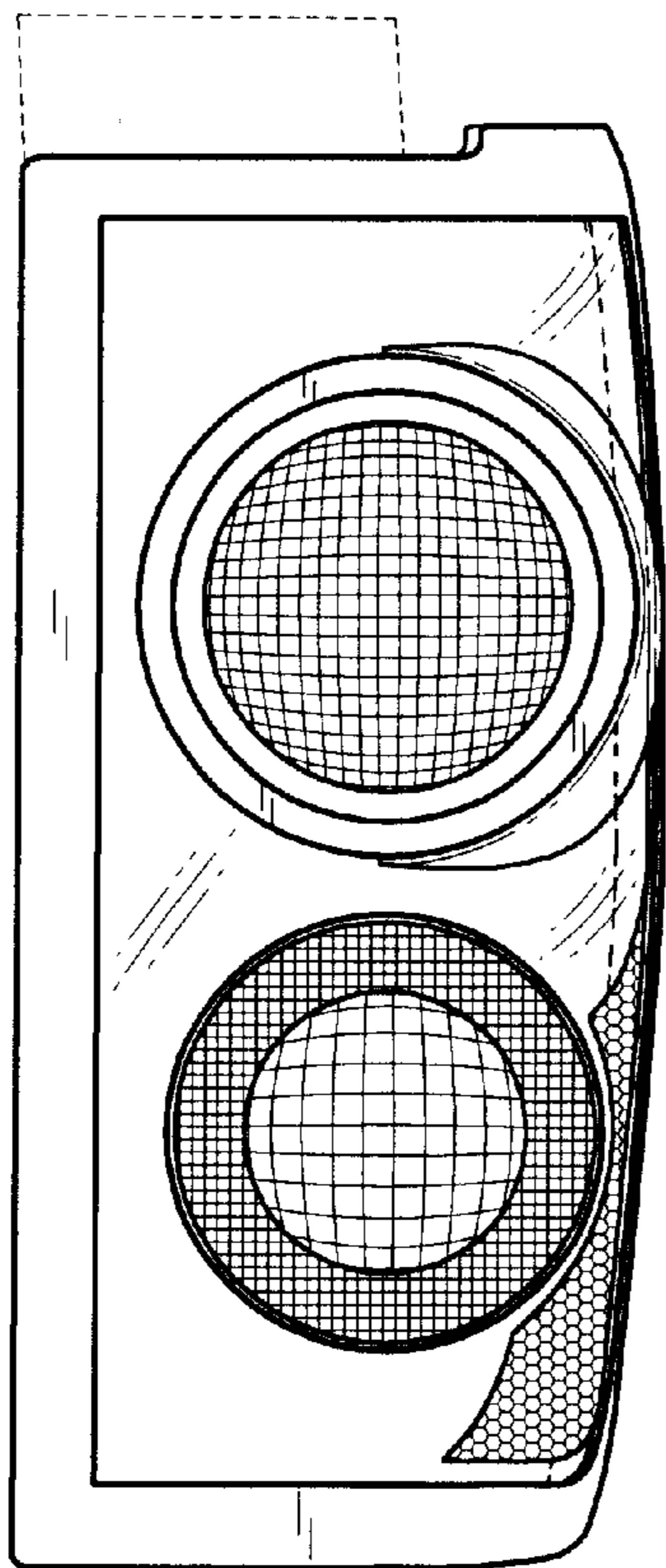

FIG. 21

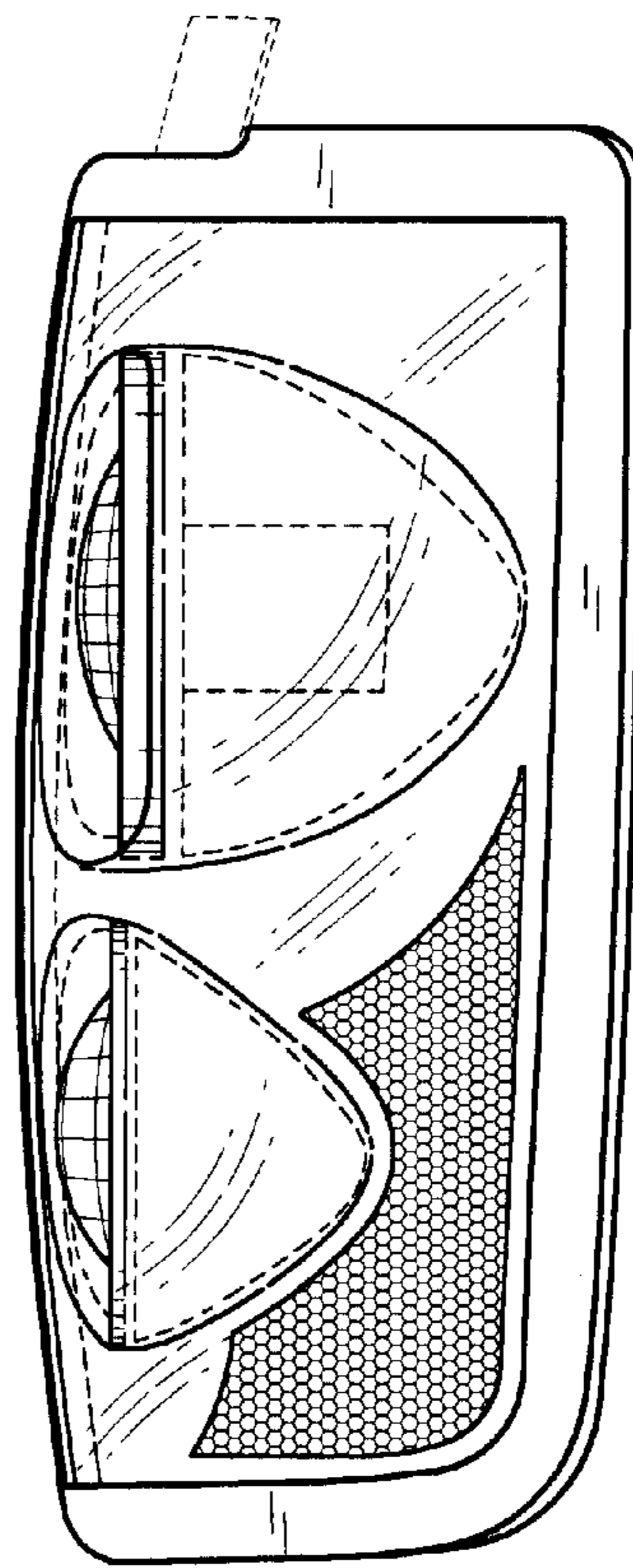

FIG. 22

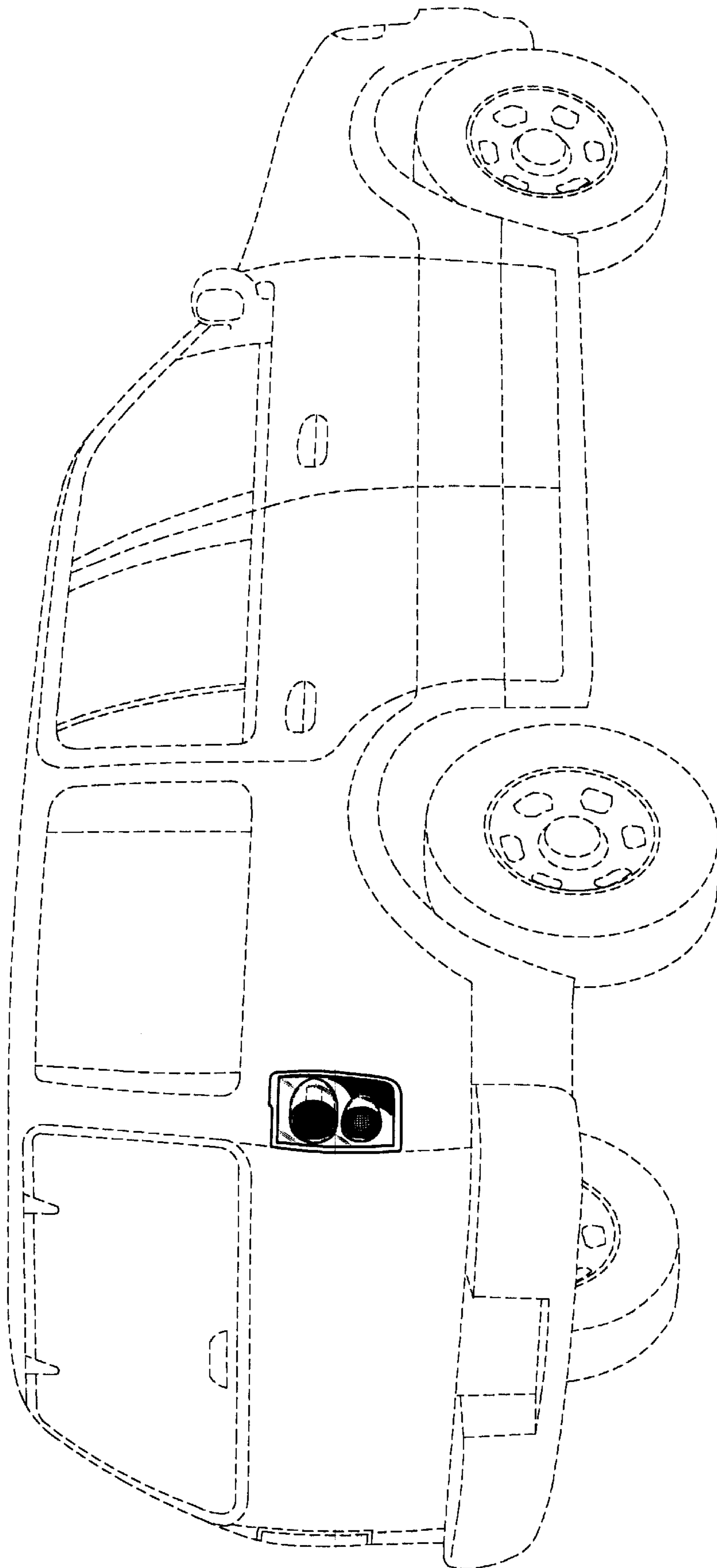

FIG. 24