



US00D472797S

(12) **United States Design Patent**
Ellis et al.

(10) **Patent No.: US D472,797 S**

(45) **Date of Patent: ** Apr. 8, 2003**

- (54) **CAPTIVE SCREW**
- (75) Inventors: **Thomas J. Ellis**, Wilmington, DE (US);
Edward A. McCormack, Chadds Ford, PA (US); **Harry L. Dickerson**,
Downingtown, PA (US); **William R. Frame**, Brookhaven, PA (US); **Steven M. Lubeck**, Aldan, PA (US)
- (73) Assignee: **Southco, Inc.**, Concordville, PA (US)
- (**) Term: **14 Years**
- (21) Appl. No.: **29/120,902**
- (22) Filed: **Mar. 28, 2000**

Related U.S. Application Data

- (63) Continuation-in-part of application No. 29/107,132, filed on Jun. 28, 1999, now abandoned, which is a continuation-in-part of application No. 29/089,913, filed on Jun. 25, 1998, now abandoned.
- (51) **LOC (7) Cl. 08-08**
- (52) **U.S. Cl. D8/387**
- (58) **Field of Search D8/310, 312, 347, D8/382, 387, 394, 397; 411/107, 108, 349, 350, 352, 353, 5, 103, 222, 366, 367, 500; 248/501; 16/110.1, 111.1, 412, 413, 414, 417, 422, 430**

(56) **References Cited**

U.S. PATENT DOCUMENTS

- 748,078 A 12/1903 Kaisling
- 1,166,345 A 12/1915 Gates
- 1,188,420 A 6/1916 Eadie
- 1,664,820 A 4/1928 Hughes
- 2,006,359 A 7/1935 Lackner
- 2,151,255 A 3/1939 Witchger
- 2,331,322 A 10/1943 Heinick
- D140,862 S 4/1945 Conlan
- D140,863 S 4/1945 Conlan
- 2,464,133 A 3/1949 Herbert
- 2,470,927 A 5/1949 Hale, Jr.
- 2,503,189 A 4/1950 Biba, Jr.

- 2,553,236 A 5/1951 Bratfisch
- 2,831,520 A 4/1958 Clarke
- 2,900,697 A 8/1959 Cuss
- 2,967,557 A 1/1961 Tait et al.
- 2,987,811 A 6/1961 Acres
- 3,033,260 A 5/1962 Snow
- 3,052,942 A 9/1962 Mulvaney
- 3,059,736 A 10/1962 Boyd
- 3,126,935 A 3/1964 Tuozzo
- 3,137,336 A 6/1964 Wing
- 3,180,389 A 4/1965 Frank
- 3,195,600 A 7/1965 Middleton, Jr.
- 3,204,680 A 9/1965 Barry
- 3,209,807 A 10/1965 Ryner
- 3,244,212 A 4/1966 Barry
- 3,245,450 A 4/1966 Sauter
- 3,250,559 A 5/1966 Sommerfeld
- 3,263,728 A 8/1966 Lynch
- 3,279,302 A 10/1966 Modrey
- 3,343,581 A 9/1967 Martin et al.
- 3,346,032 A 10/1967 Gulistan
- 3,385,341 A 5/1968 Garstkiewicz
- 3,437,119 A 4/1969 Dey
- 3,465,803 A 9/1969 Ernest et al.
- 3,502,130 A 3/1970 Gulistan
- 3,564,563 A 2/1971 Trotter et al.
- 3,718,950 A 3/1973 Engstrom
- 3,912,411 A 10/1975 Moffat
- 3,958,308 A 5/1976 Gooding
- 4,007,516 A 2/1977 Coules
- 4,047,266 A 9/1977 Bisbing
- 4,387,497 A 6/1983 Gulistan
- 4,398,322 A 8/1983 Ewen
- 4,472,098 A 9/1984 Kiefer
- 4,492,500 A 1/1985 Ewing
- D283,591 S 4/1986 Swanstrom
- 4,594,040 A 6/1986 Molina
- 4,602,903 A 7/1986 Wilburn
- 4,692,075 A 9/1987 Metz
- 4,915,557 A 4/1990 Stafford
- 4,952,107 A 8/1990 Dupree
- 5,042,880 A 8/1991 Garuti et al.
- 5,056,974 A 10/1991 Dolin
- D324,479 S 3/1992 Tinz
- 5,094,579 A 3/1992 Johnson
- 5,120,168 A 6/1992 Padula
- 5,209,018 A 5/1993 Heinrich
- 5,336,028 A 8/1994 Yamamoto
- 5,338,139 A 8/1994 Swanstrom

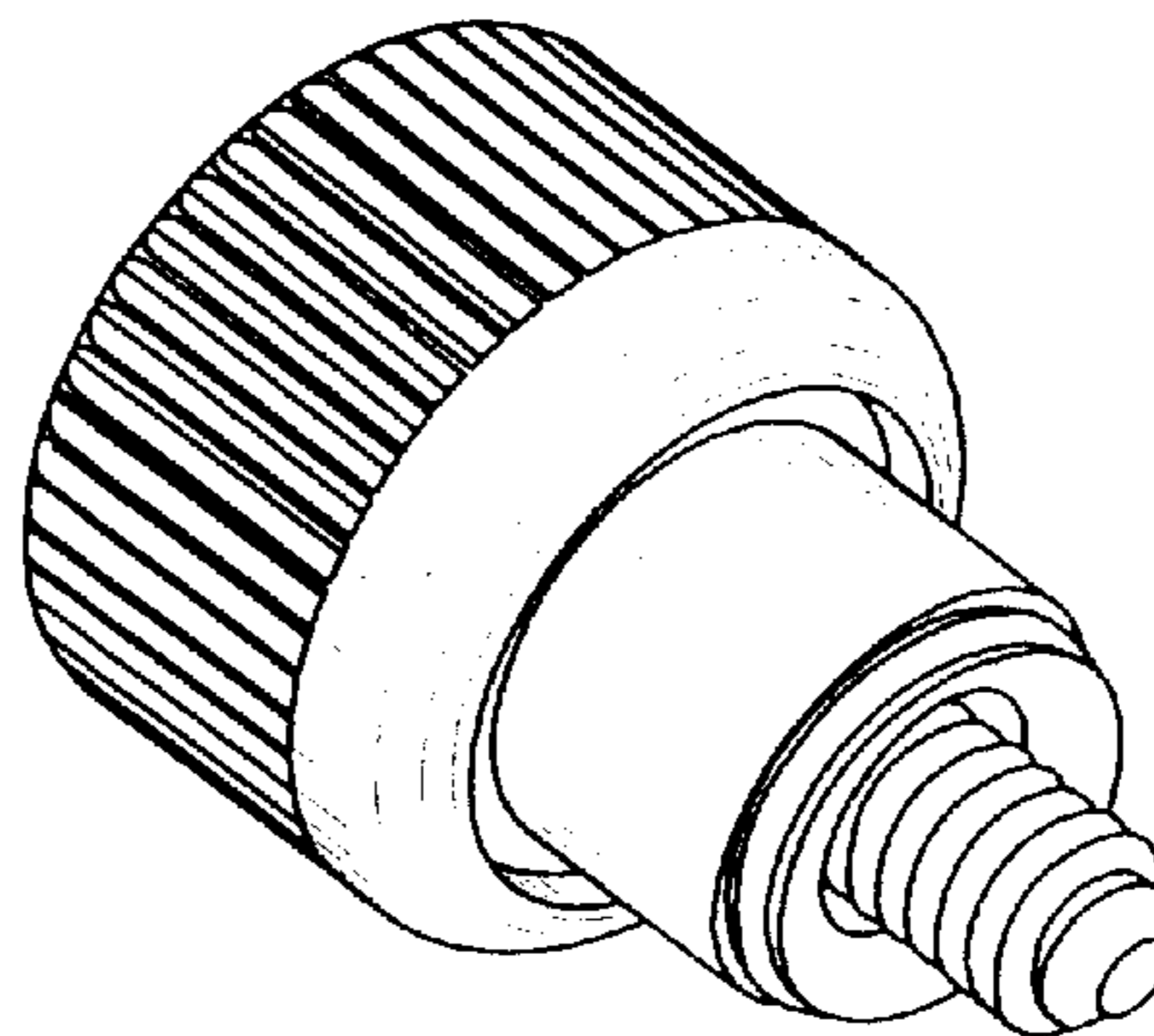
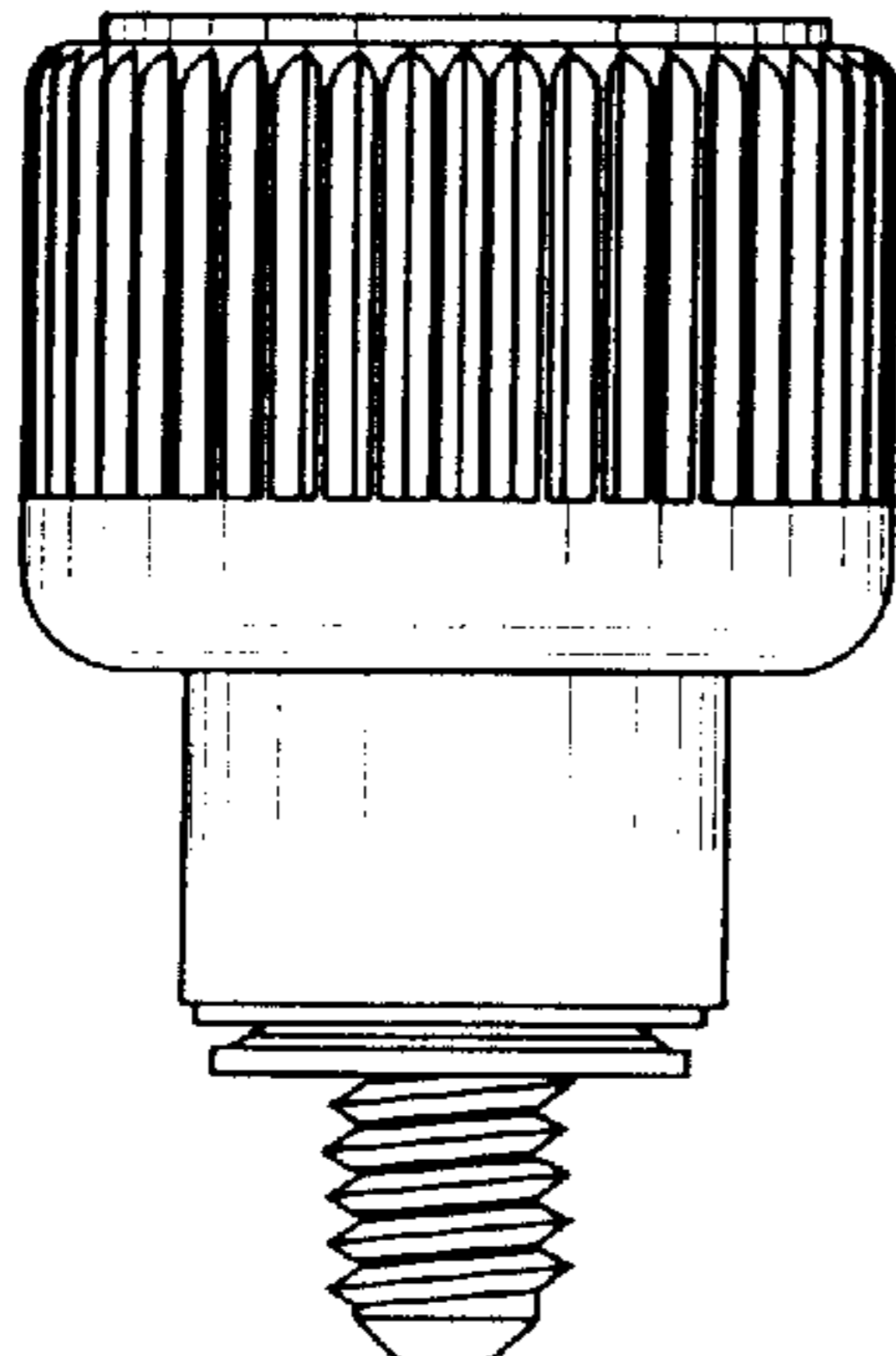

5,382,124	A	1/1995	Frattarola
D357,176	S	4/1995	Ernest et al.
5,429,467	A	7/1995	Gugle et al.
5,537,262	A	7/1996	Aoki et al.
5,544,992	A	8/1996	Ciobanu et al.
5,611,654	A	3/1997	Frattarola et al.
5,642,972	A	7/1997	Ellis et al.
5,667,346	A	9/1997	Sharp
D388,316	S	12/1997	McDonough et al.
5,741,101	A	4/1998	Gulistan
D400,430	S	11/1998	McDonough et al.
D402,522	S	12/1998	Gillman
5,851,095	A	12/1998	Ellis et al.
5,865,582	A	2/1999	Ellis et al.
D411,952	S	7/1999	Alderisio, Jr.
D417,827	S	12/1999	Gillman
6,033,168	A	3/2000	Creely, III et al.

FOREIGN PATENT DOCUMENTS

CA	558456	6/1958
CA	766082	8/1967
FR	3245450	11/1962
FR	2268977	4/1975
FR	2578009	2/1986
FR	2636384	9/1988
GB	626013	9/1949
GB	825877	12/1959
GB	1579730	11/1980

OTHER PUBLICATIONS

Southco Latches and Access Hardware Handbook 45 NA, pp. B19–B22 and C1–C44.
 Southco Latches and Access Hardware Handbook n—47 NA, pp. C1–C3.
 Penn Engineering & Manufacturing Corp., Snap–Top Stand-offs, Pem Bulletin SSA–988, (Danboro, PA).
 Penn Engineering & Manufacturing Corp., Fasteners for Use In or With PC Boards, Pem Bulletin K–488, (Danboro, PA).
 Penn Engineering & Manufacturing Corp., “Type PF 11 Self–Clinching Panel Fastener Assembly,” Pem Bulletin PF11–297, (Danboro, PA).
 Penn Engineering & Manufacturing Corp., Fastener Guide–Pem’s 1996 Catalog, (Danboro, PA).
 Camloc Fasteners, 1993 Catalog, pp. C8–C12 (Hasbrouck Heights, NJ).
 Huck International, Inc., “Captive Fasteners and Rivetless Nut Plates,” Huck 1996 Catalog (California, 90712).
 Huck International, Inc., Deutschert, Press–in Captive Screw, Floating, Retractable, 1 pg., Lakewood, CA 1994.
 Matdan American Corp., Brochure, (Cincinnati, Ohio).
 Kanebridge Corp., 1994 Catalog, pp. I, III, 211–214, 245–246 (New Jersey).

Primary Examiner—Alan P. Douglas
Assistant Examiner—Clare E. Hefflin
 (74) *Attorney, Agent, or Firm*—Paul & Paul

(57) CLAIM

The ornamental design for a captive screw, as shown and described.

DESCRIPTION

FIG. 1 is a side elevation of a captive screw showing our new design, all remaining sides being identical;
 FIG. 2 is a perspective view thereof;
 FIG. 3 is a bottom plan view thereof;

FIG. 4 is a top plan view thereof showing a six lobed driver recess;
 FIG. 5 is an alternate top plan view thereof showing a combined six lobed/slotted driver recess;
 FIG. 6 is an alternate top plan view thereof showing a slotted driver recess;
 FIG. 7 is an alternate top plan view thereof showing a Phillips driver recess;
 FIG. 8 is an alternate top plan view thereof showing a combined slotted/Phillips driver recess;
 FIG. 9 is a side elevation of a captive screw showing a second embodiment of our new design, all remaining sides being identical;
 FIG. 10 is a perspective view thereof;
 FIG. 11 is a bottom plan view thereof;
 FIG. 12 is a top plan view thereof showing a six lobed driver recess;
 FIG. 13 is an alternate top plan view thereof showing a combined six lobed/slotted driver recess;
 FIG. 14 is an alternate top plan view thereof showing a slotted driver recess;
 FIG. 15 is an alternate top plan view thereof showing a Phillips driver recess;
 FIG. 16 is an alternate top plan view thereof showing a combined slotted/Phillips driver recess;
 FIG. 17 is a side elevation of a captive screw showing a third embodiment of our new design, all remaining sides being identical;
 FIG. 18 is a perspective view thereof;
 FIG. 19 is a bottom plan view thereof;
 FIG. 20 is a top plan view thereof showing a six lobed driver recess;
 FIG. 21 is an alternate top plan view thereof showing a combined six lobed/slotted driver recess;
 FIG. 22 is an alternate top plan view thereof showing a slotted driver recess;
 FIG. 23 is an alternate top plan view thereof showing a Phillips driver recess;
 FIG. 24 is an alternate top plan view thereof showing a combined slotted/Phillips driver recess;
 FIG. 25 is a side elevation of a captive screw showing a fourth embodiment of our new design, all remaining sides being identical;
 FIG. 26 is a perspective view thereof;
 FIG. 27 is a bottom plan view thereof;
 FIG. 28 is a top plan view thereof showing a six lobed driver recess;
 FIG. 29 is an alternate top plan view thereof showing a combined six lobed/slotted driver recess;
 FIG. 30 is an alternate top plan view thereof showing a slotted driver recess;
 FIG. 31 is an alternate top plan view thereof showing a Phillips driver recess;
 FIG. 32 is an alternate top plan view thereof showing a combined slotted/Phillips driver recess;
 FIG. 33 is a side elevation of a captive screw showing a fifth embodiment of our new design, all remaining sides being identical;
 FIG. 34 is a perspective view thereof;
 FIG. 35 is a bottom plan view thereof;
 FIG. 36 is a top plan view thereof showing a six lobed driver recess;
 FIG. 37 is an alternate top plan view thereof showing a combined six lobed/slotted driver recess;

FIG. 38 is an alternate top plan view thereof showing a slotted driver recess;

FIG. 39 is an alternate top plan view thereof showing a Phillips driver recess;

FIG. 40 is an alternate top plan view thereof showing a combined slotted/Phillips driver recess;

FIG. 41 is a side elevation of a captive screw showing a sixth embodiment of our new design, all remaining sides being identical;

FIG. 42 is a perspective view thereof;

FIG. 43 is a bottom plan view thereof;

FIG. 44 is a top plan view thereof showing a six lobed driver recess;

FIG. 45 is an alternate top plan view thereof showing a combined six lobed/slotted driver recess;

FIG. 46 is an alternate top plan view thereof showing a slotted driver recess;

FIG. 47 is an alternate top plan view thereof showing a Phillips driver recess;

FIG. 48 is an alternate top plan view thereof showing a combined slotted/Phillips driver recess;

FIG. 49 is a side elevation of a captive screw showing a seventh embodiment of our new design, all remaining sides being identical;

FIG. 50 is a perspective view thereof;

FIG. 51 is a bottom plan view thereof;

FIG. 52 is a top plan view thereof showing a six lobed driver recess;

FIG. 53 is an alternate top plan view thereof showing a combined six lobed/slotted driver recess;

FIG. 54 is an alternate top plan view thereof showing a slotted driver recess;

FIG. 55 is an alternate top plan view thereof showing a Phillips driver recess;

FIG. 56 is an alternate top plan view thereof showing a combined slotted/Phillips driver recess;

FIG. 57 is a side elevation of a captive screw showing an eighth embodiment of our new design, all remaining sides being identical;

FIG. 58 is a perspective view thereof;

FIG. 59 is a bottom plan view thereof;

FIG. 60 is a top plan view thereof showing a six lobed driver recess;

FIG. 61 is an alternate top plan view thereof showing a combined six lobed/ slotted driver recess;

FIG. 62 is an alternate top plan view thereof showing a slotted driver recess;

FIG. 63 is an alternate top plan view thereof showing a Phillips driver recess;

FIG. 64 is an alternate top plan view thereof showing a combined slotted/Phillips driver recess;

FIG. 65 is a side elevation of a captive screw showing a ninth embodiment of our new design, all remaining sides being identical;

FIG. 66 is a perspective view thereof;

FIG. 67 is a bottom plan view thereof;

FIG. 68 is a top plan view thereof showing a six lobed driver recess;

FIG. 69 is an alternate top plan view thereof showing a combined six lobed/slotted driver recess;

FIG. 70 is an alternate top plan view thereof showing a slotted driver recess;

FIG. 71 is an alternate top plan view thereof showing a Phillips driver recess;

FIG. 72 is an alternate top plan view thereof showing a combined slotted/Phillips driver recess;

FIG. 73 is a side elevation of a captive screw showing a tenth embodiment of our new design, all remaining sides being identical;

FIG. 74 is a perspective view thereof;

FIG. 75 is a bottom plan view thereof;

FIG. 76 is a top plan view thereof showing a six lobed driver recess;

FIG. 77 is an alternate top plan view thereof showing a combined six lobed/slotted driver recess;

FIG. 78 is an alternate top plan view thereof showing a slotted driver recess;

FIG. 79 is an alternate top plan view thereof showing a Phillips driver recess;

FIG. 80 is an alternate top plan view thereof showing a combined slotted/Phillips driver recess;

FIG. 81 is a side elevation of a captive screw showing an eleventh embodiment of our new design, all remaining sides being identical;

FIG. 82 is a perspective view thereof;

FIG. 83 is a bottom plan view thereof;

FIG. 84 is a top plan view thereof showing a six lobed driver recess;

FIG. 85 is an alternate top plan view thereof showing a combined six lobed/slotted driver recess;

FIG. 86 is an alternate top plan view thereof showing a slotted driver recess;

FIG. 87 is an alternate top plan view thereof showing a Phillips driver recess; and,

FIG. 88 is an alternate top plan view thereof showing a combined slotted/Phillips driver recess.

It is understood that for each alternate top plan view in each embodiment in the drawings, the bottom plan, perspective and side elevations are identical to those shown.

1 Claim, 11 Drawing Sheets

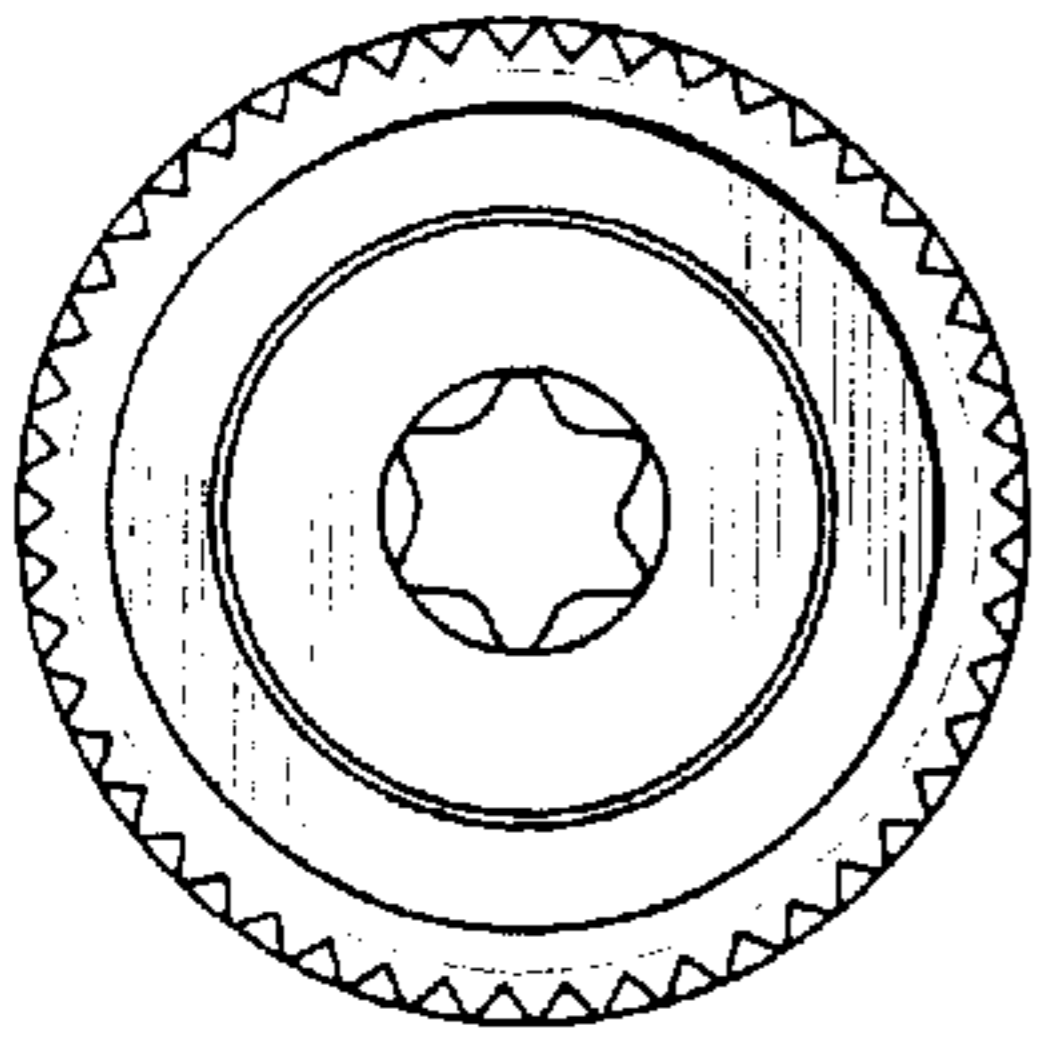

FIG. 4

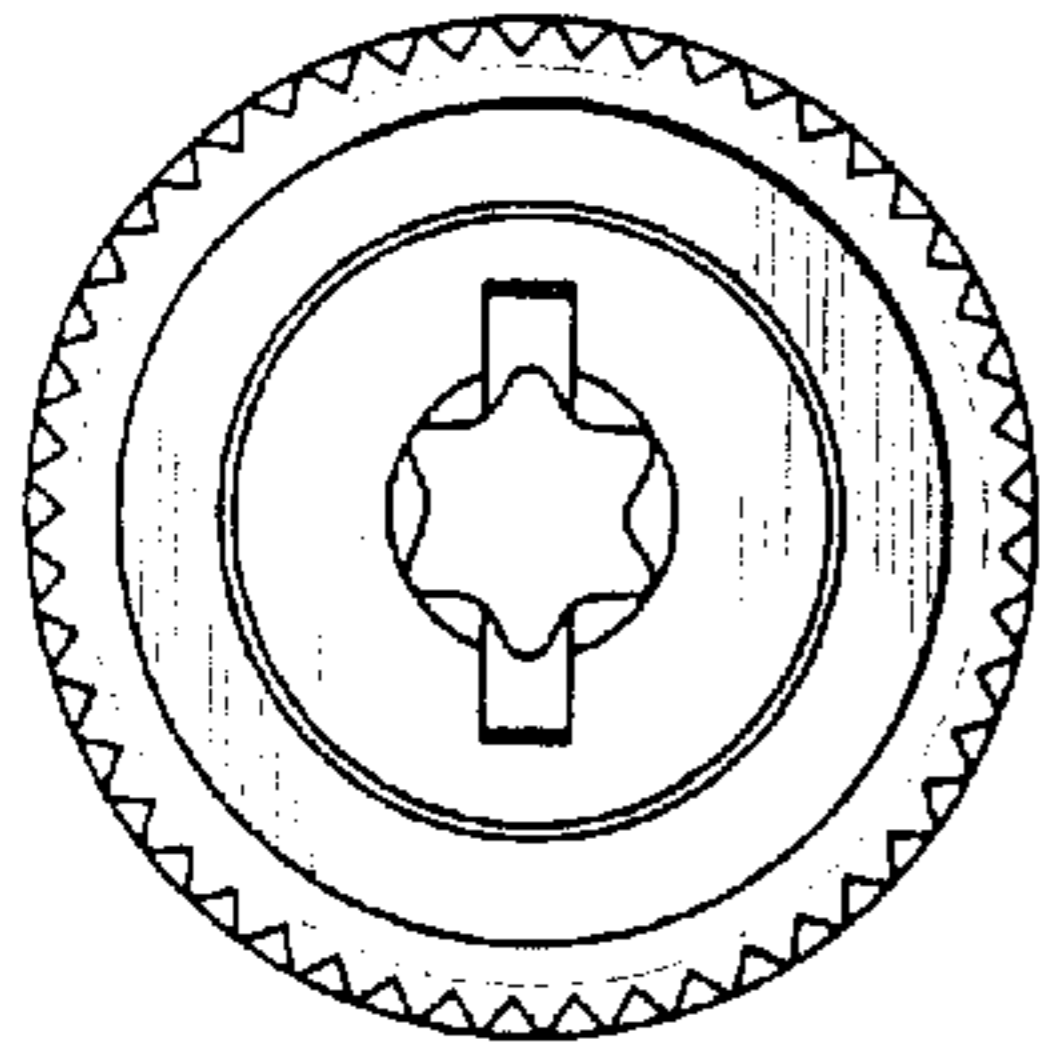

FIG. 5

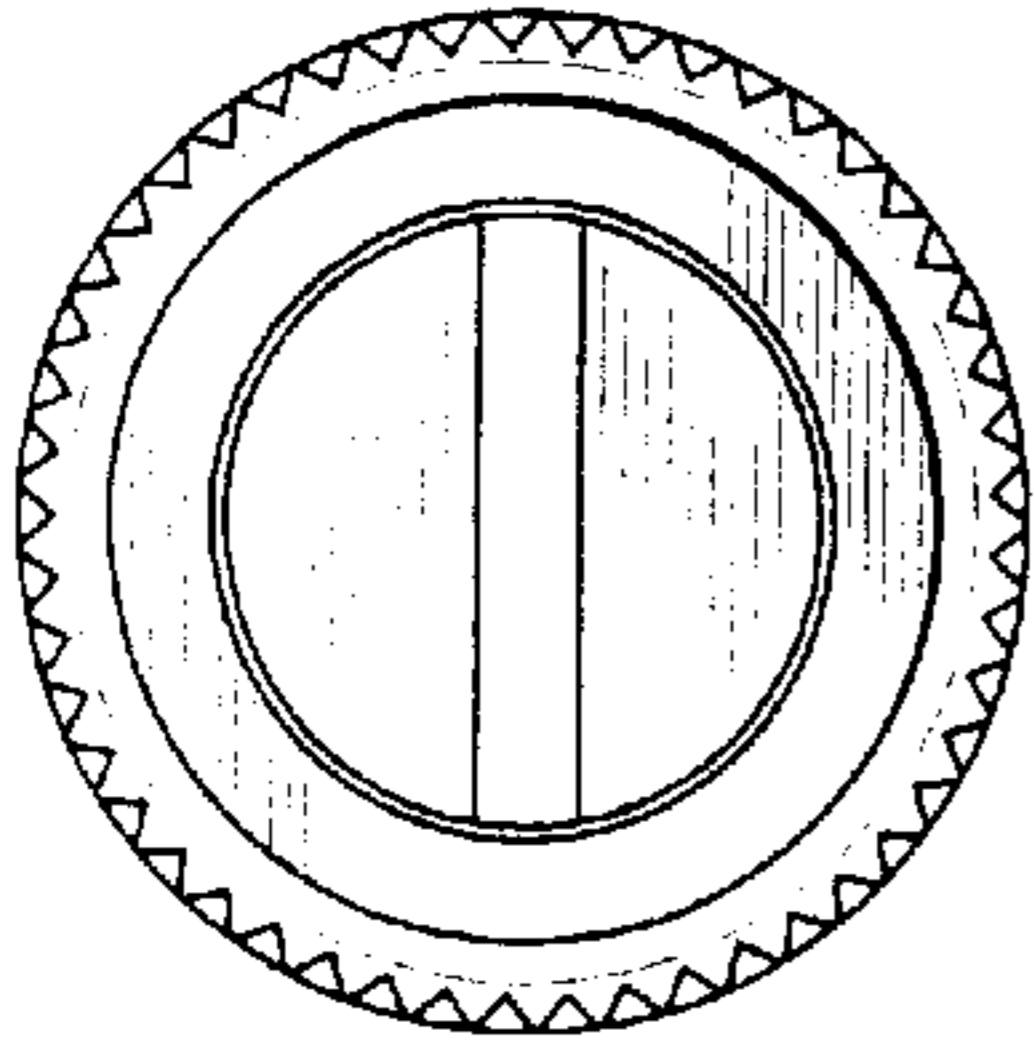

FIG. 6

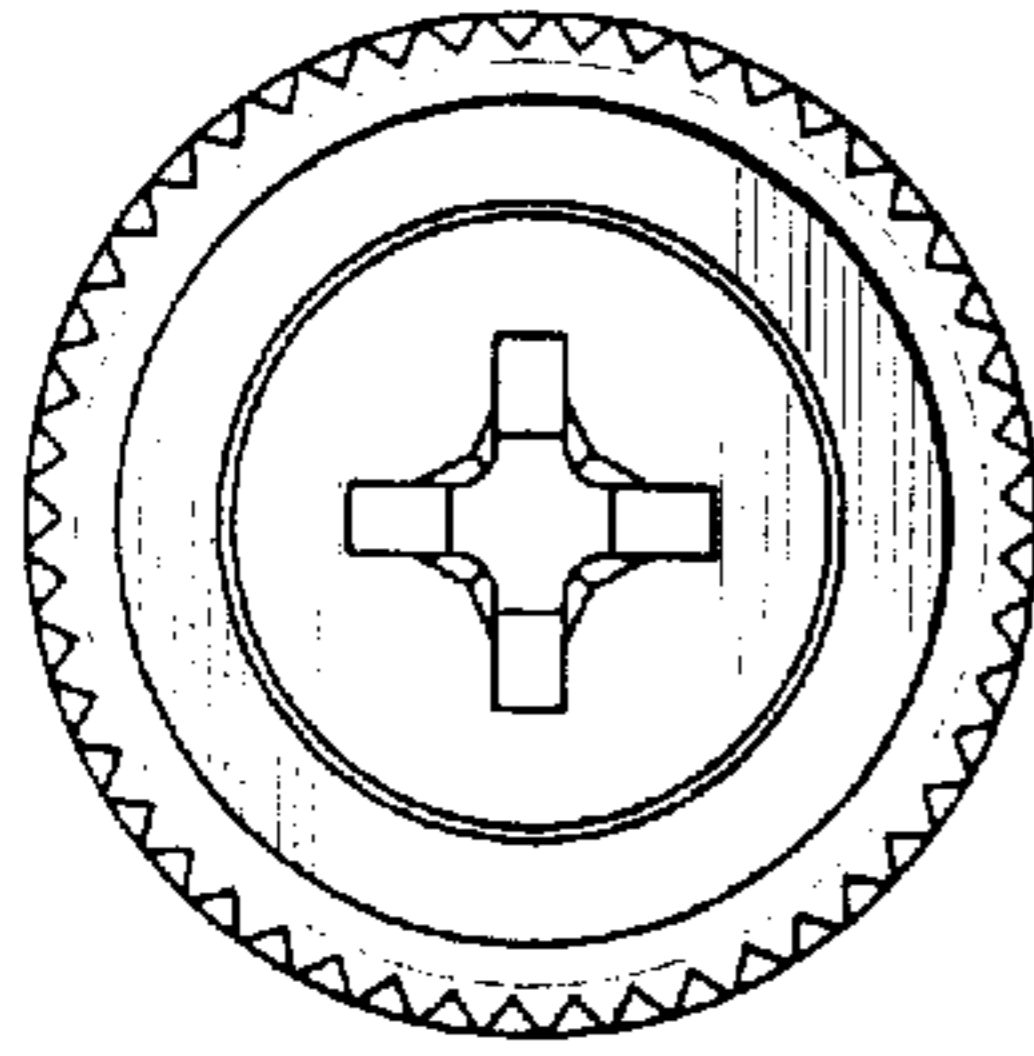

FIG. 7

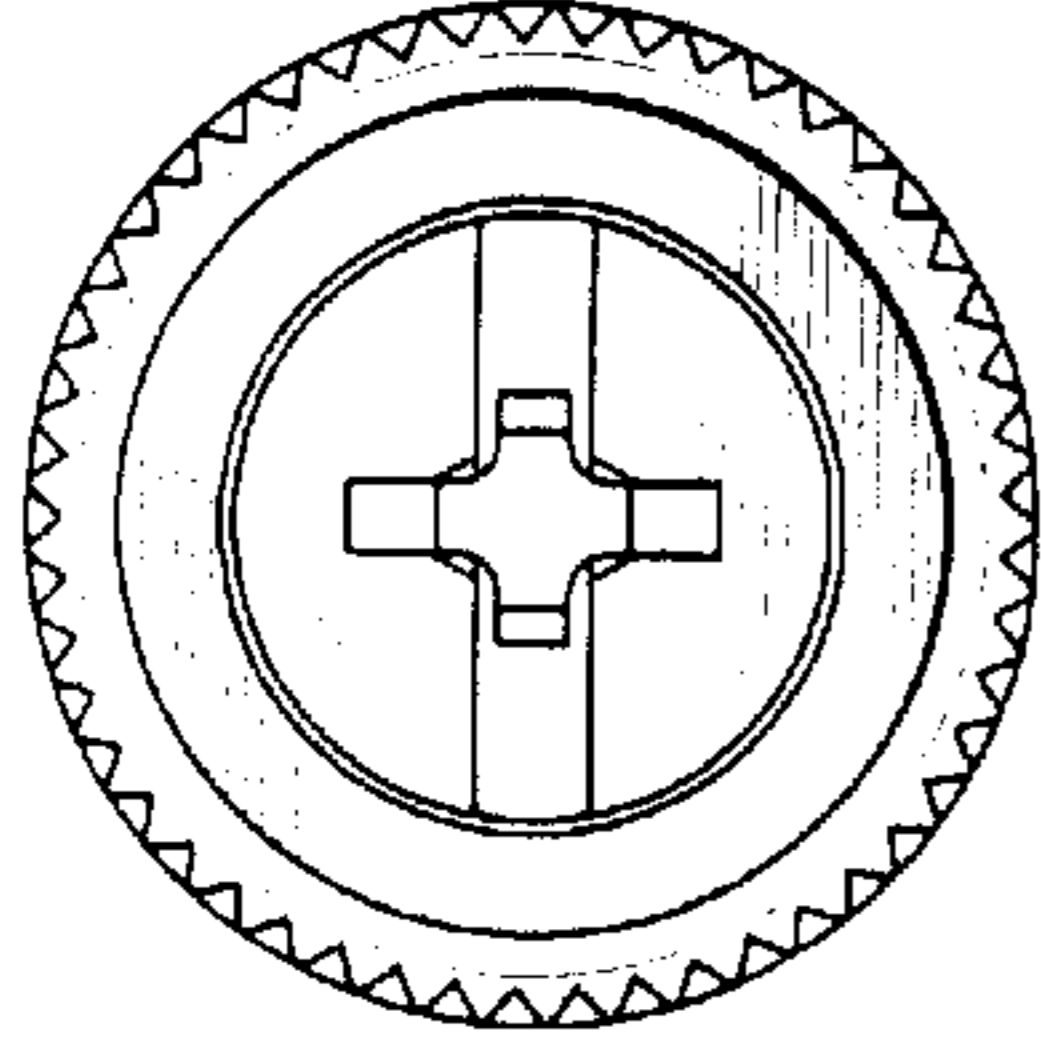

FIG. 8

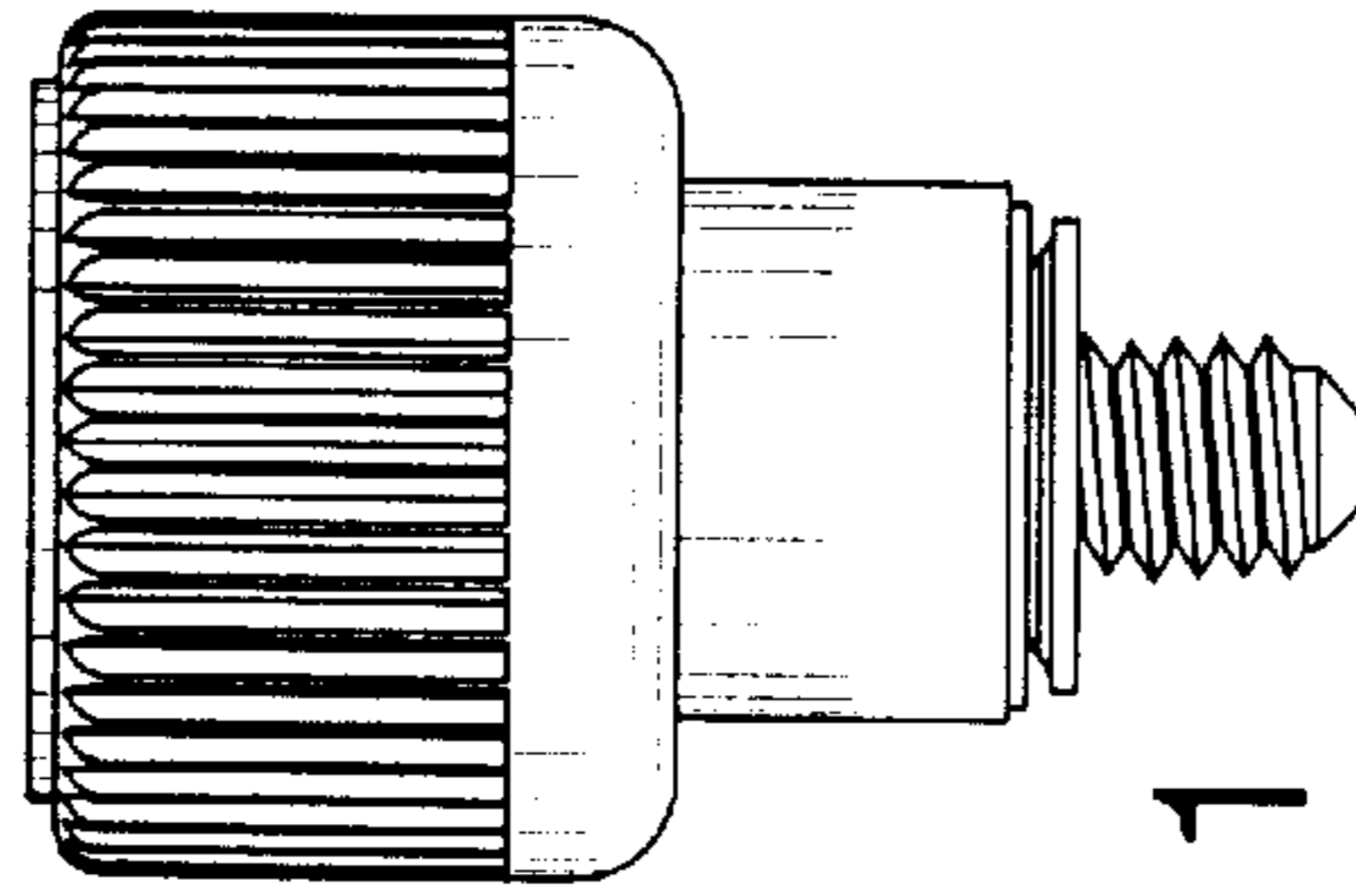

FIG. 1

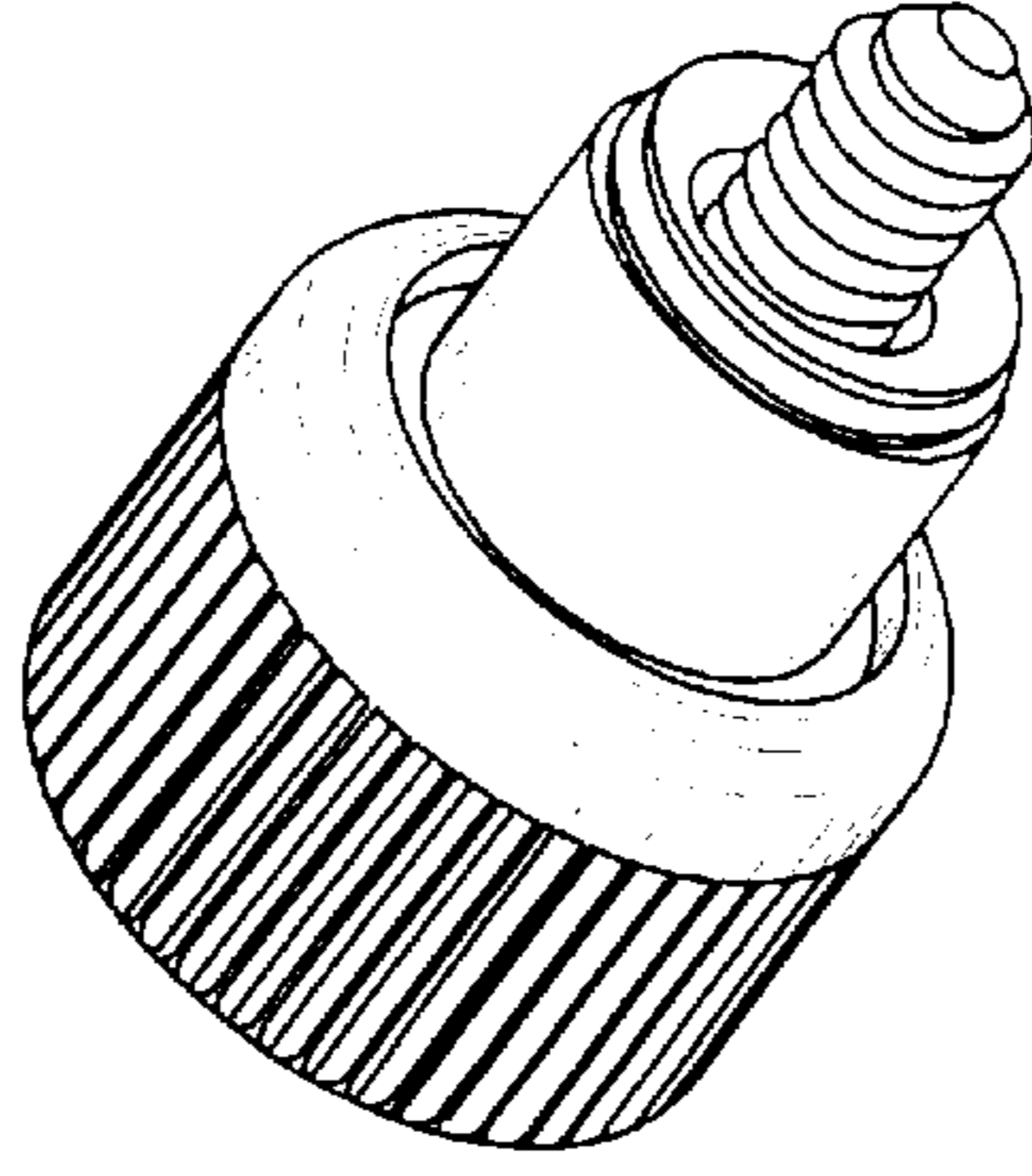

FIG. 2

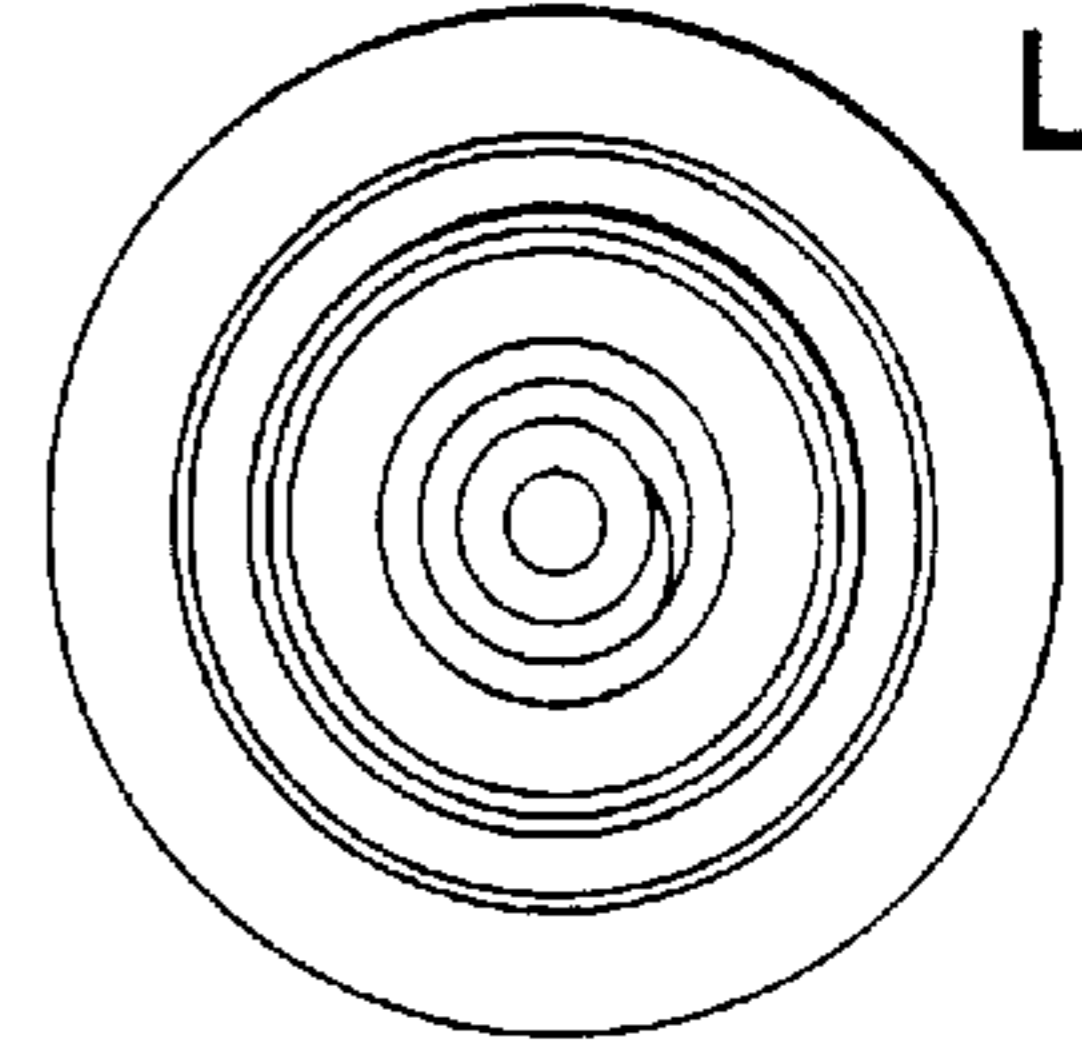

FIG. 3

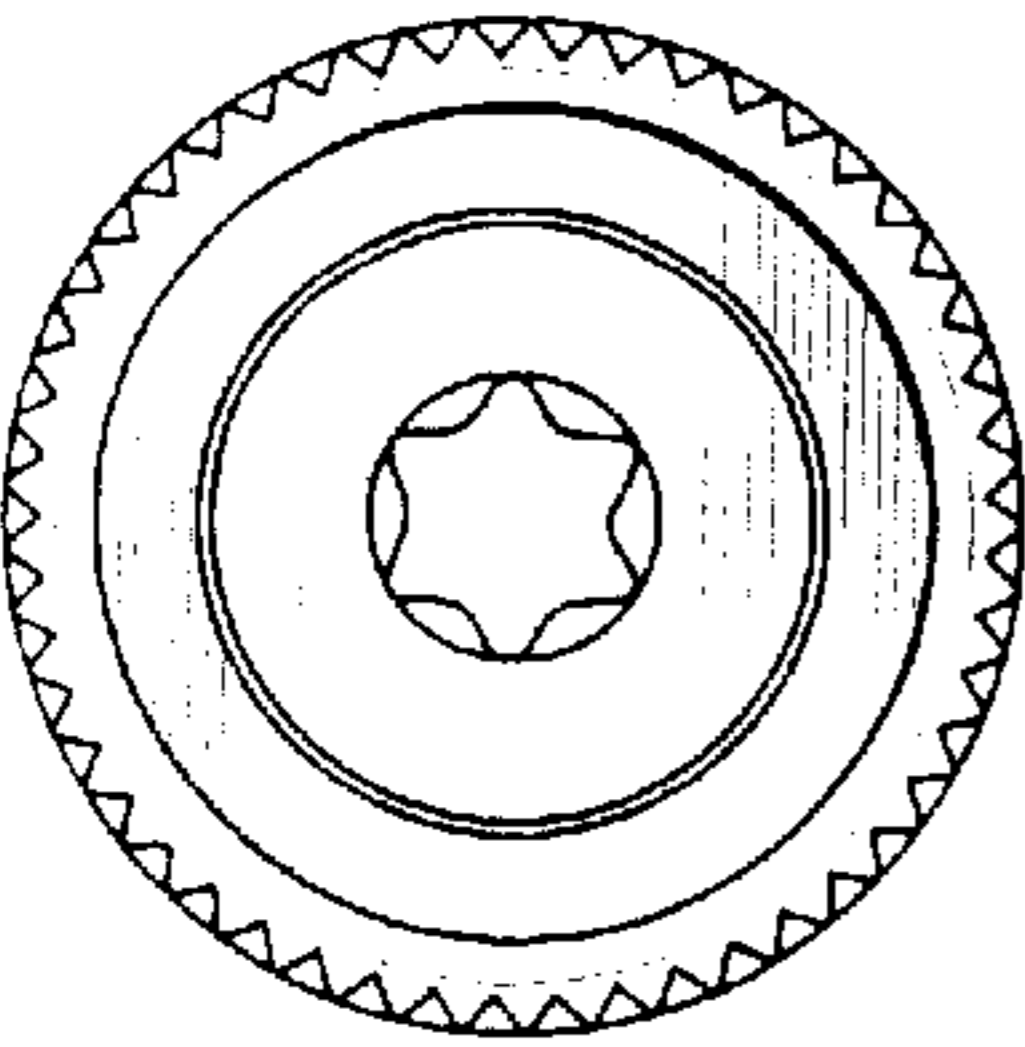

FIG. 12

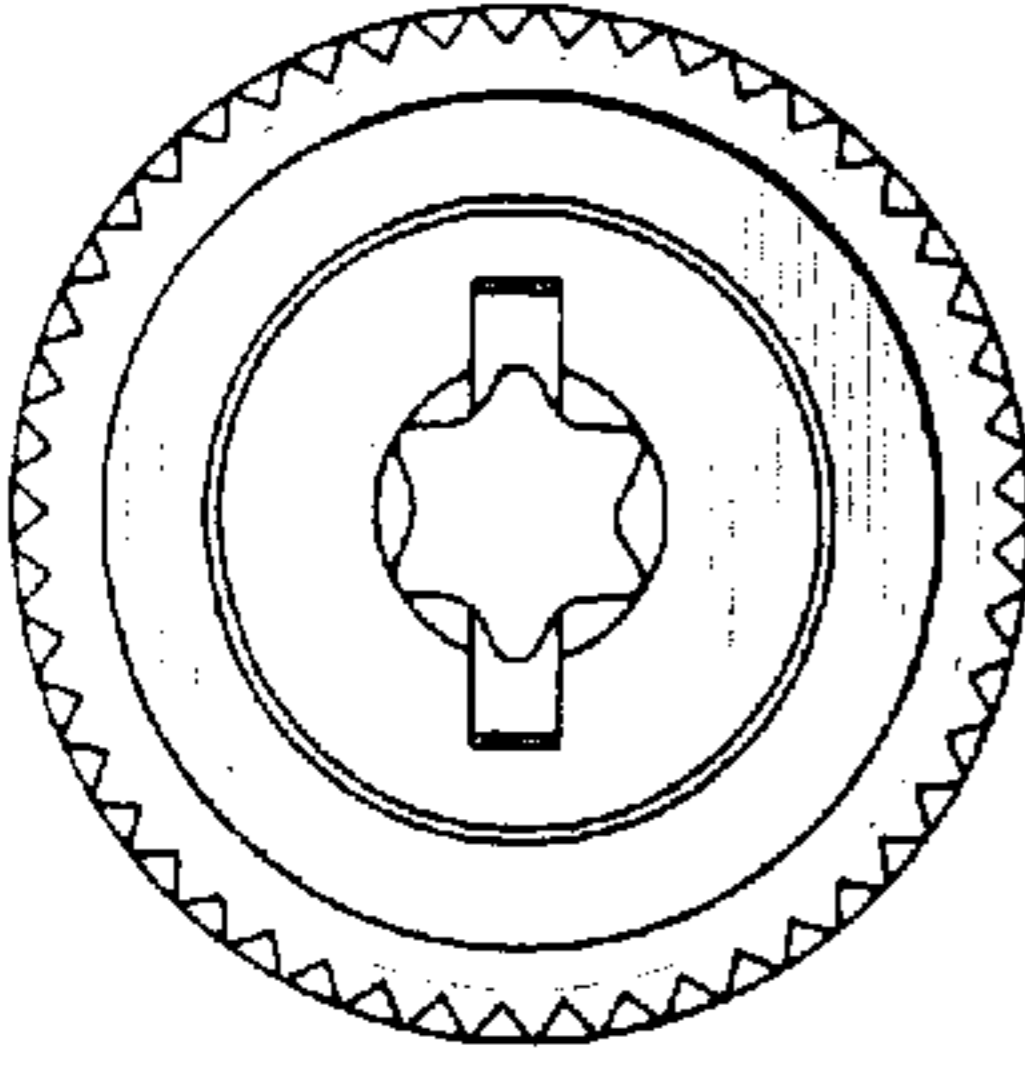

FIG. 13

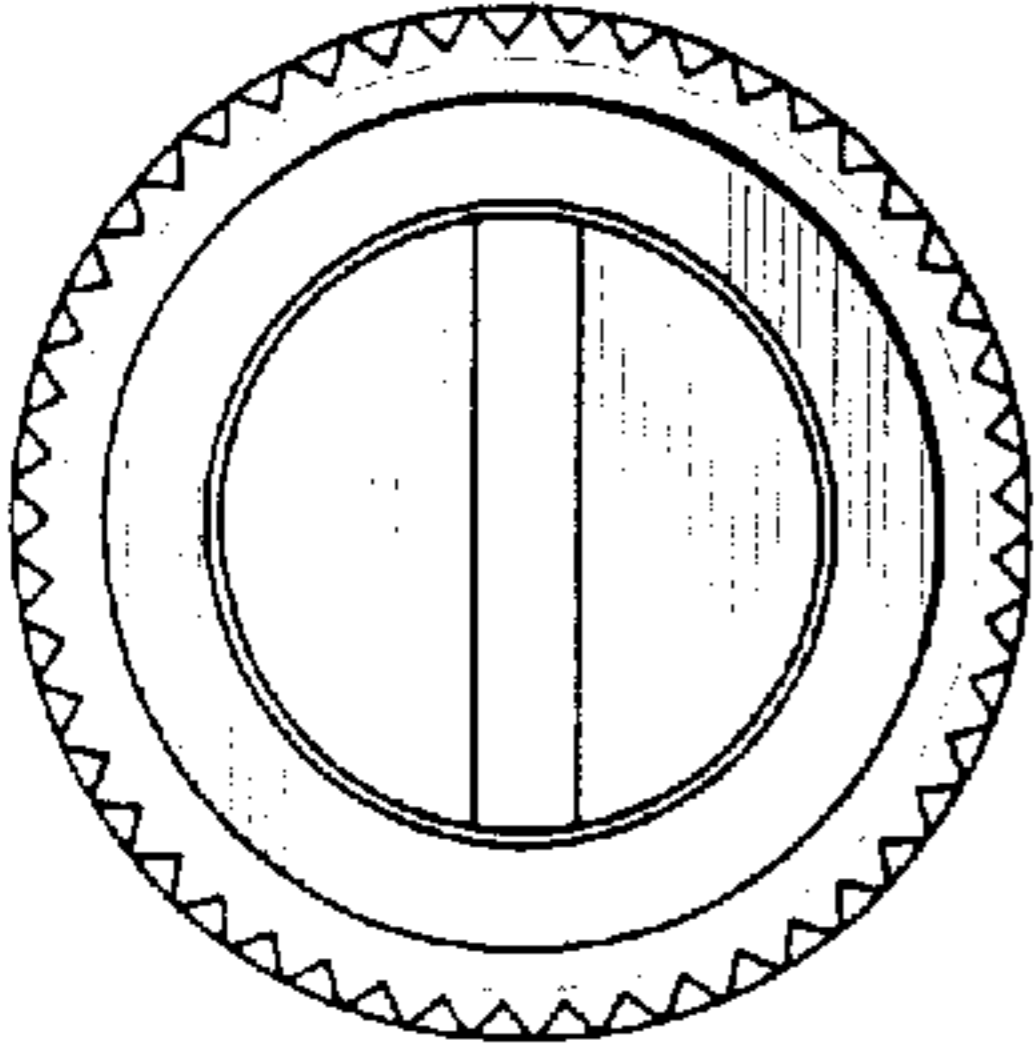

FIG. 14

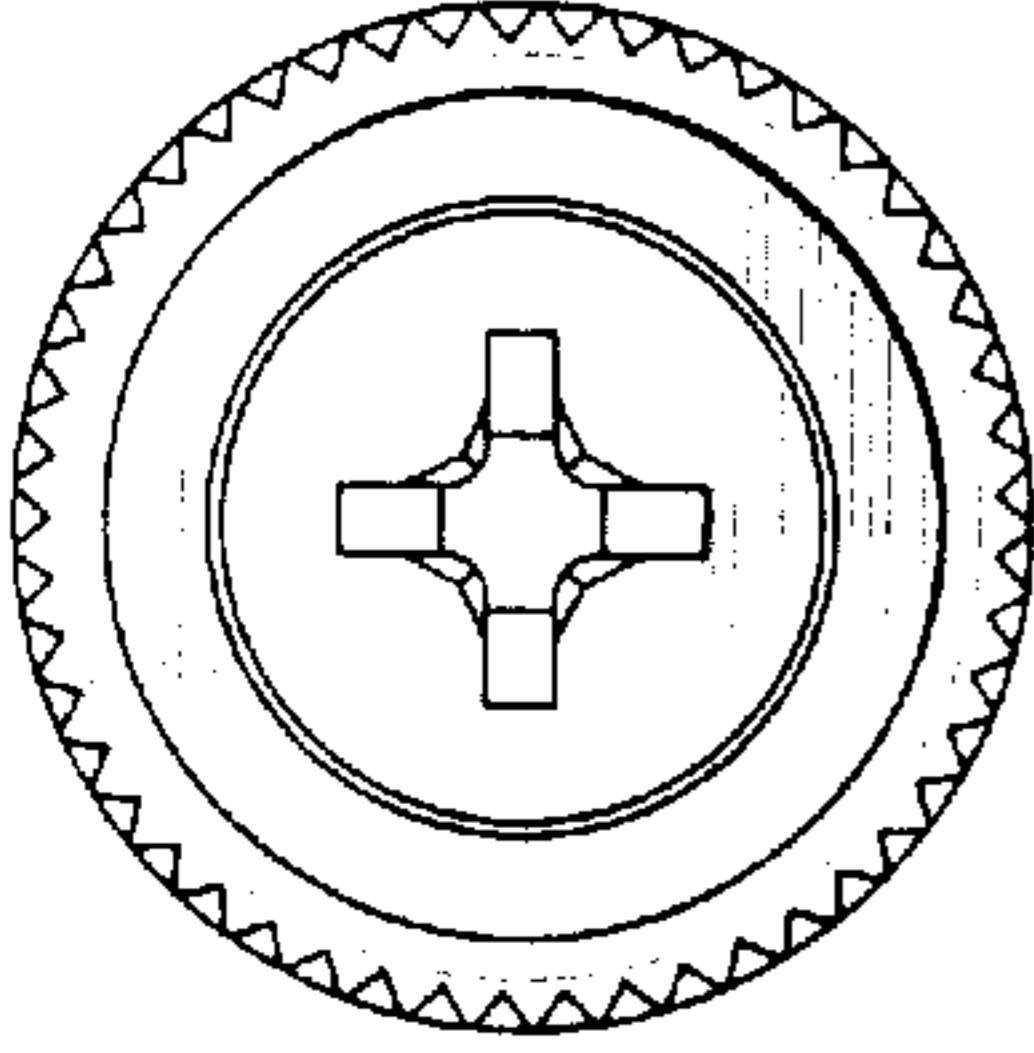

FIG. 15

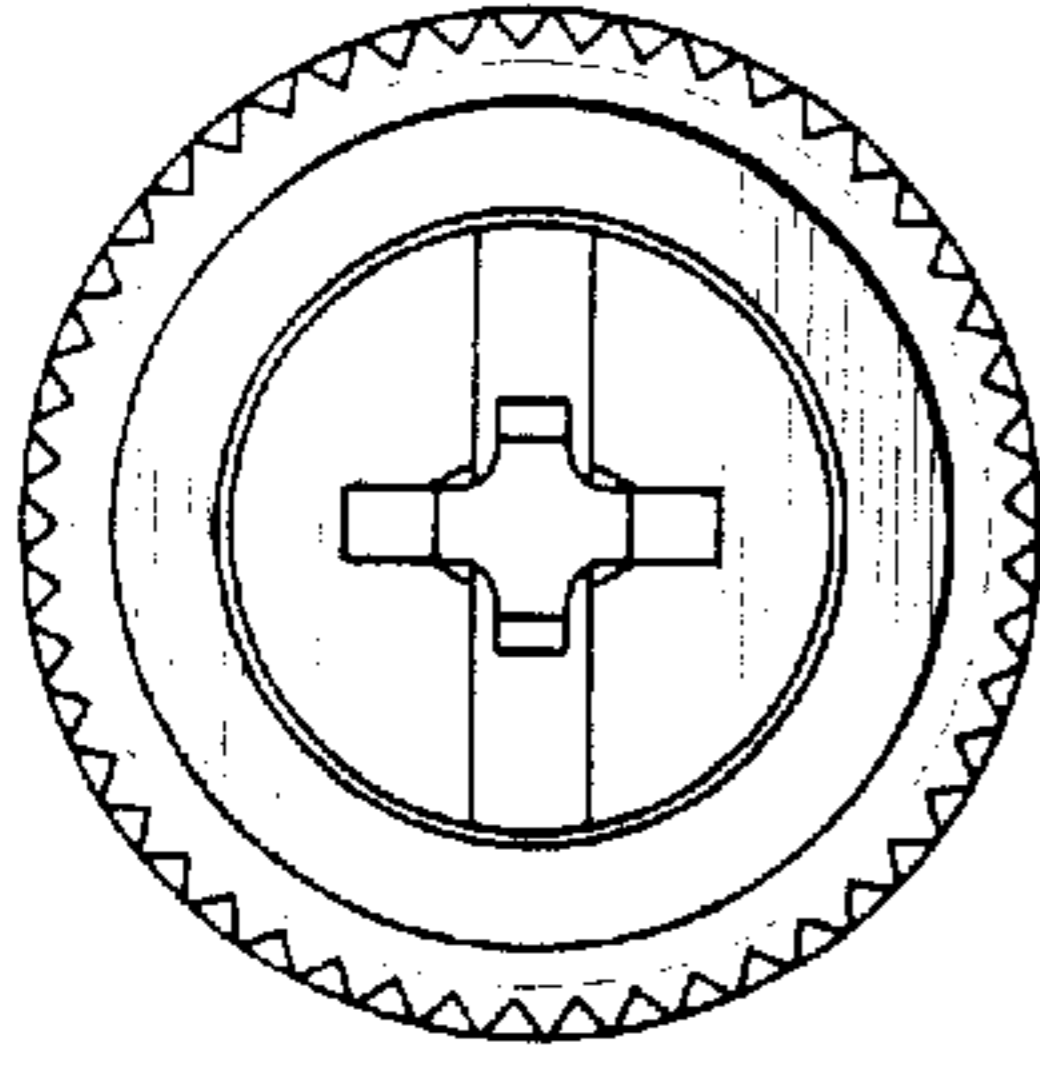

FIG. 16

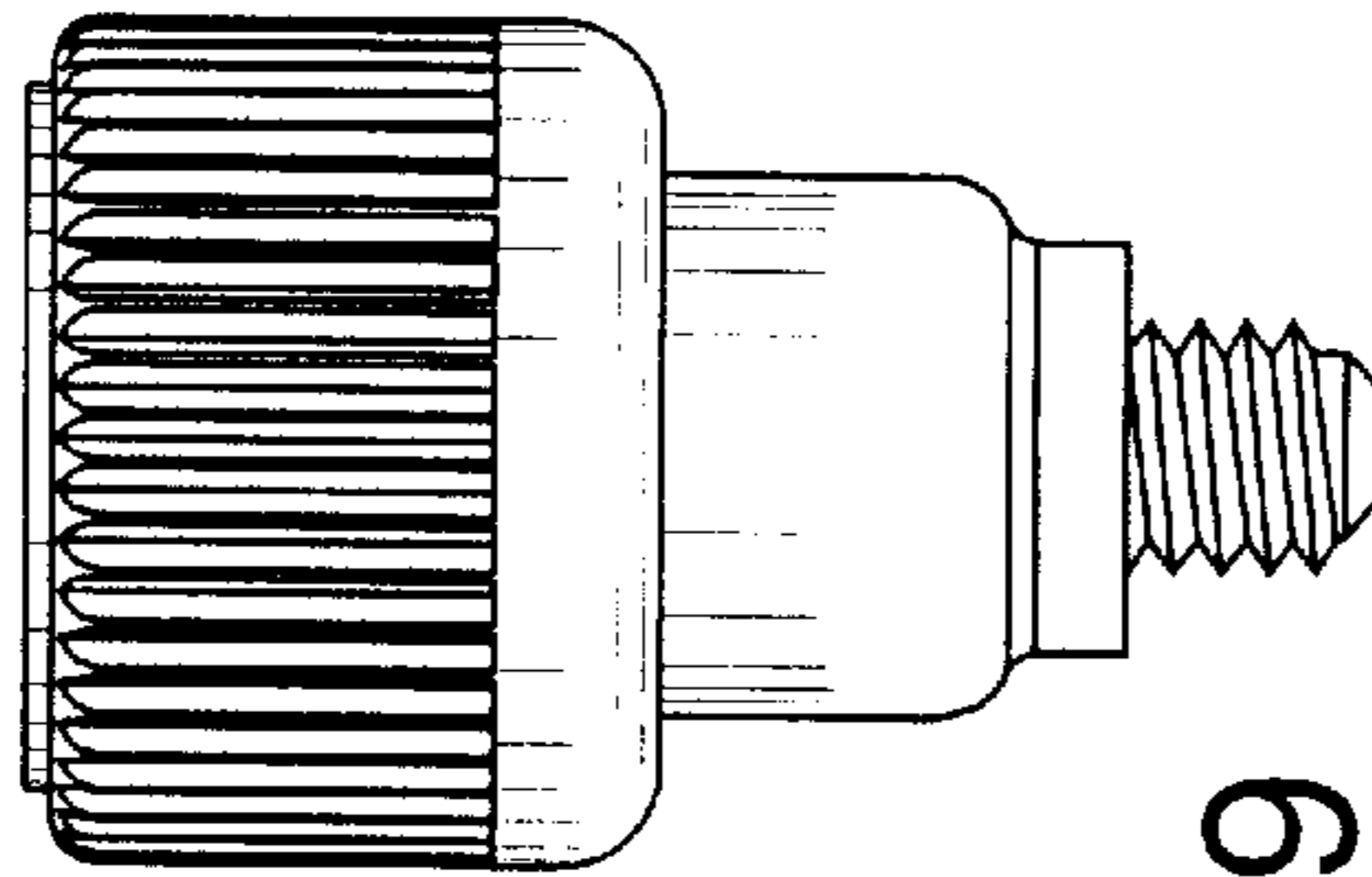

FIG. 9

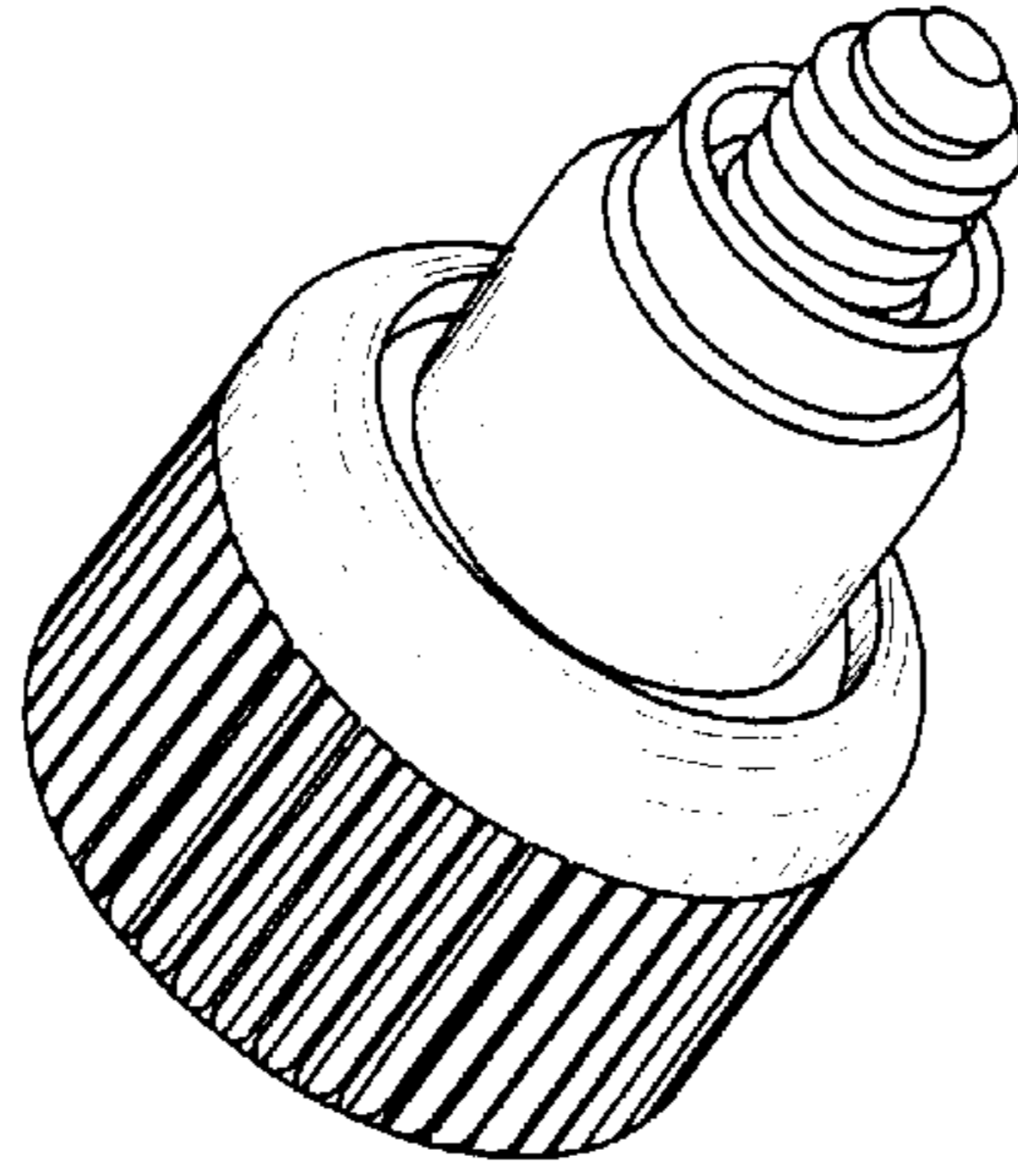

FIG. 10

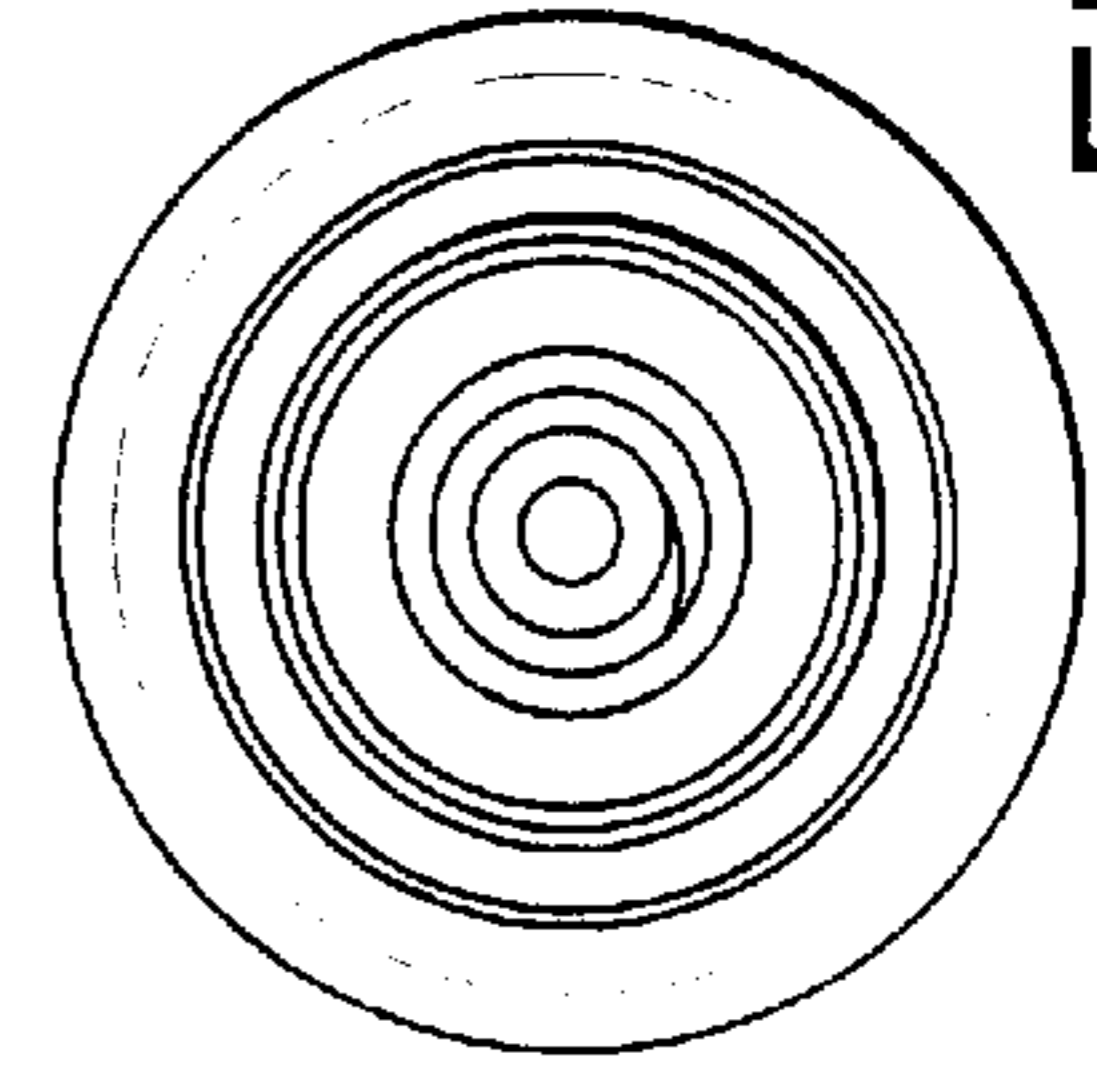

FIG. 11

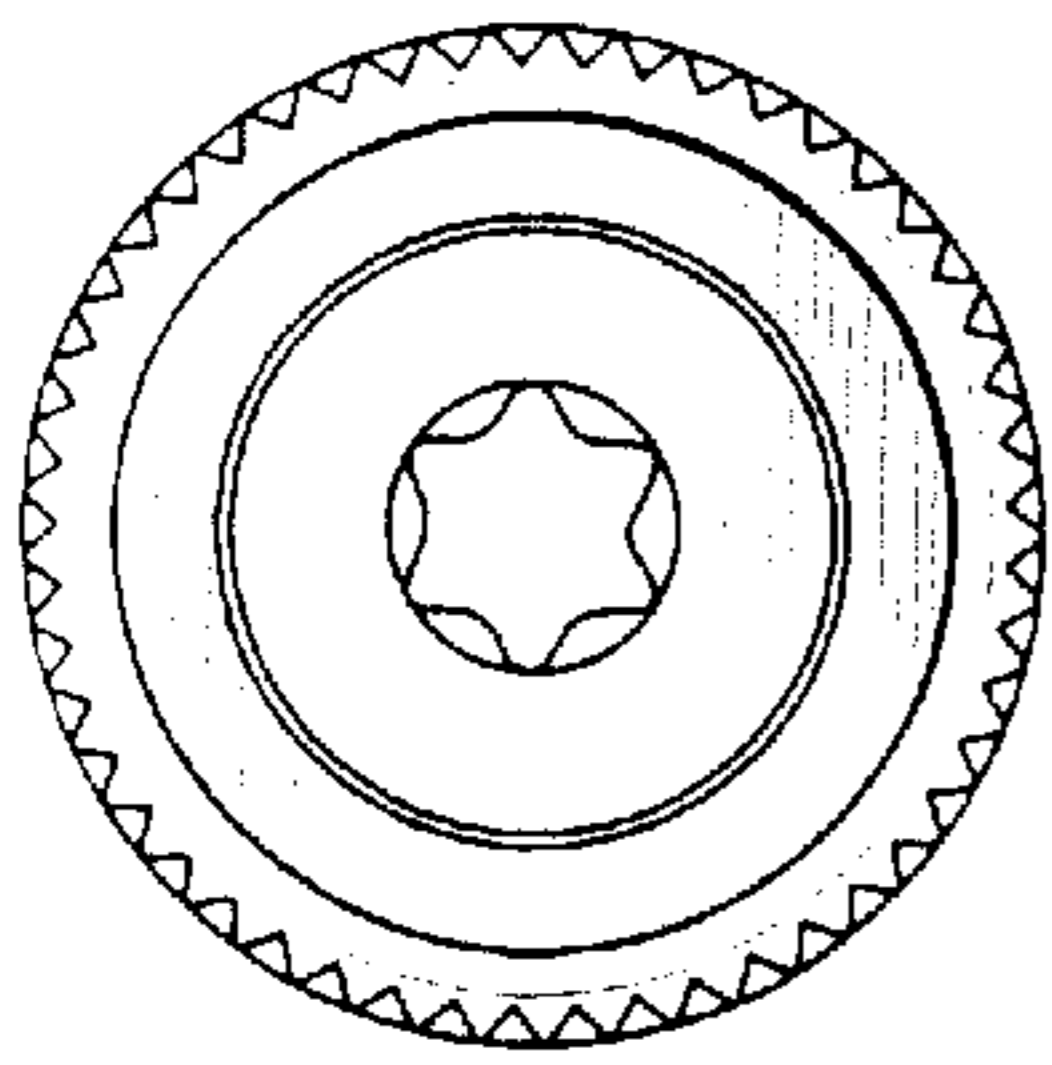

FIG. 20

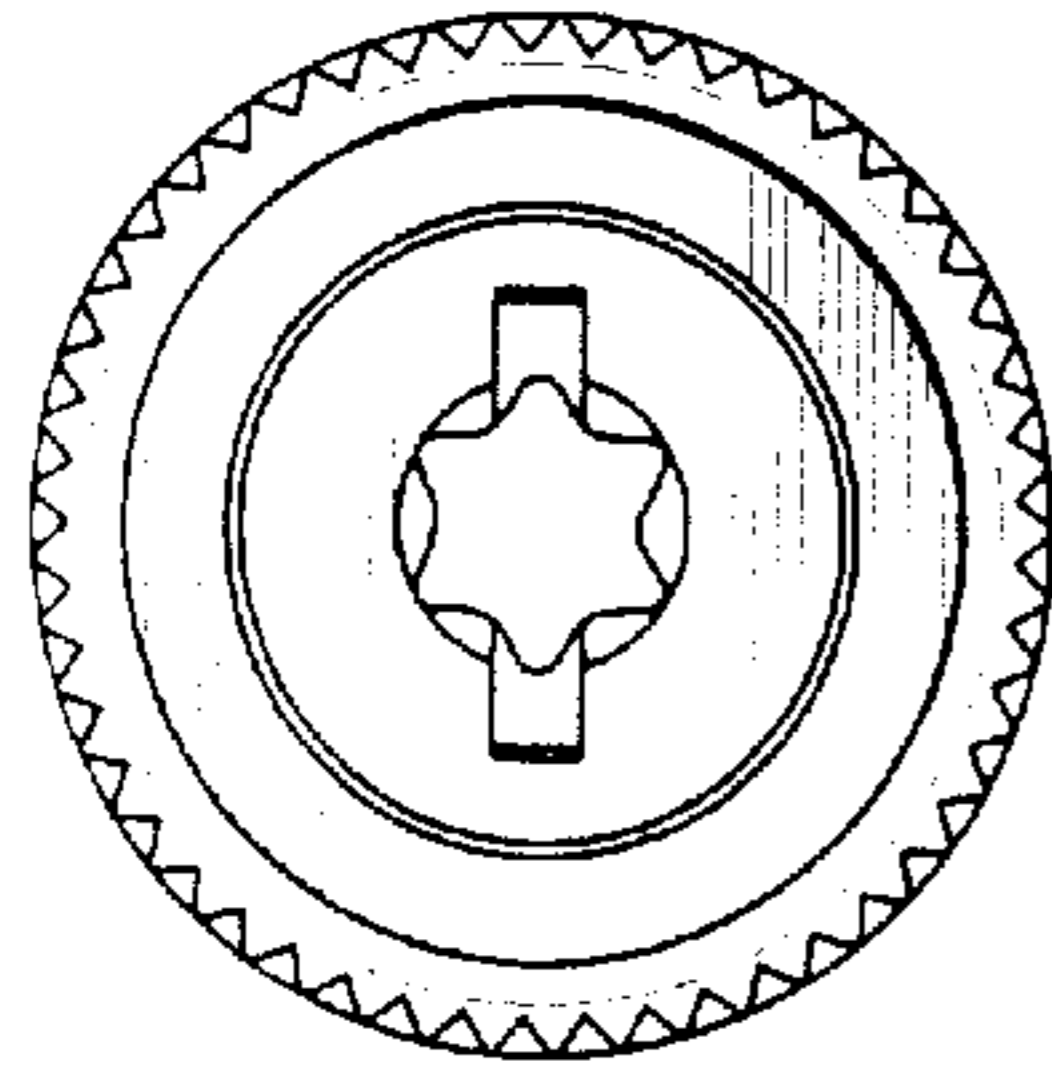

FIG. 21

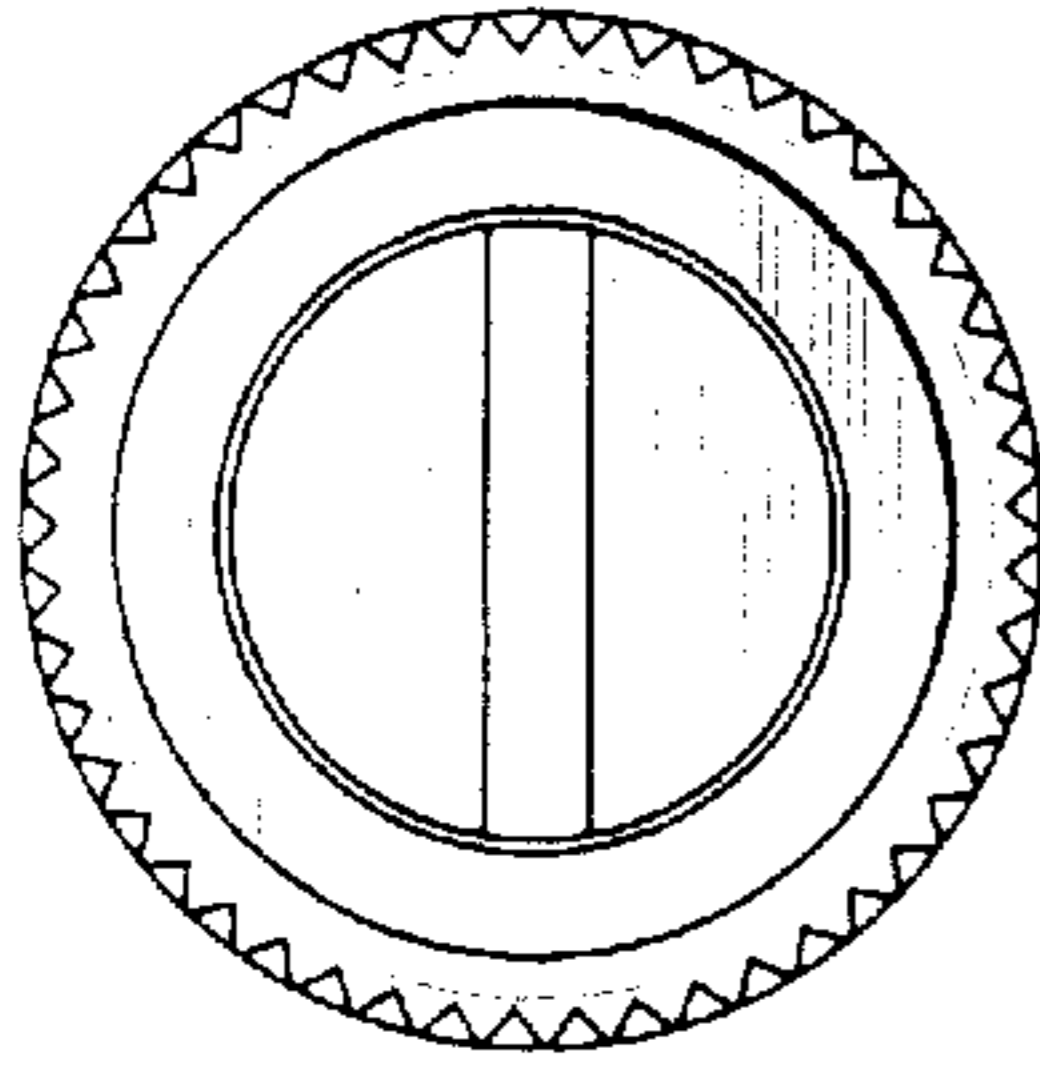

FIG. 22

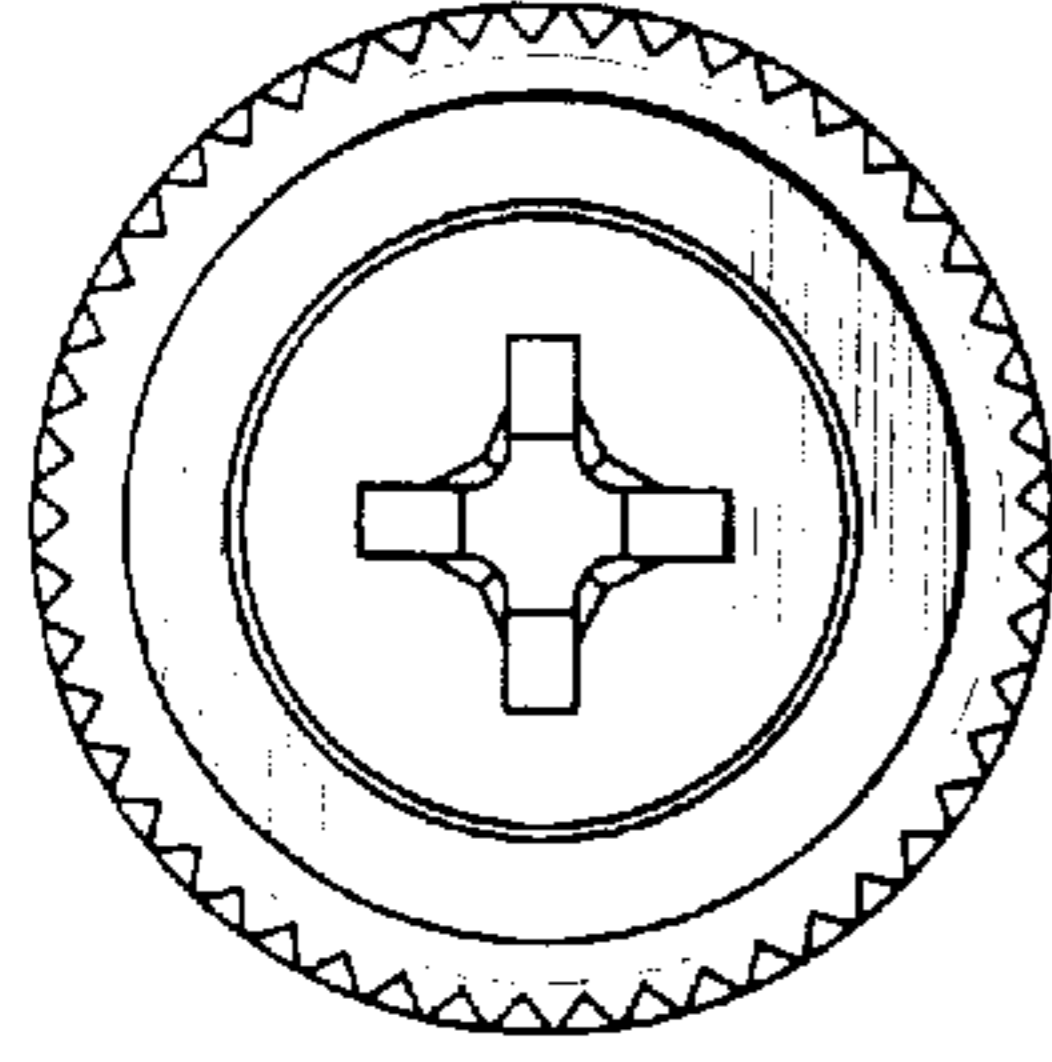

FIG. 23

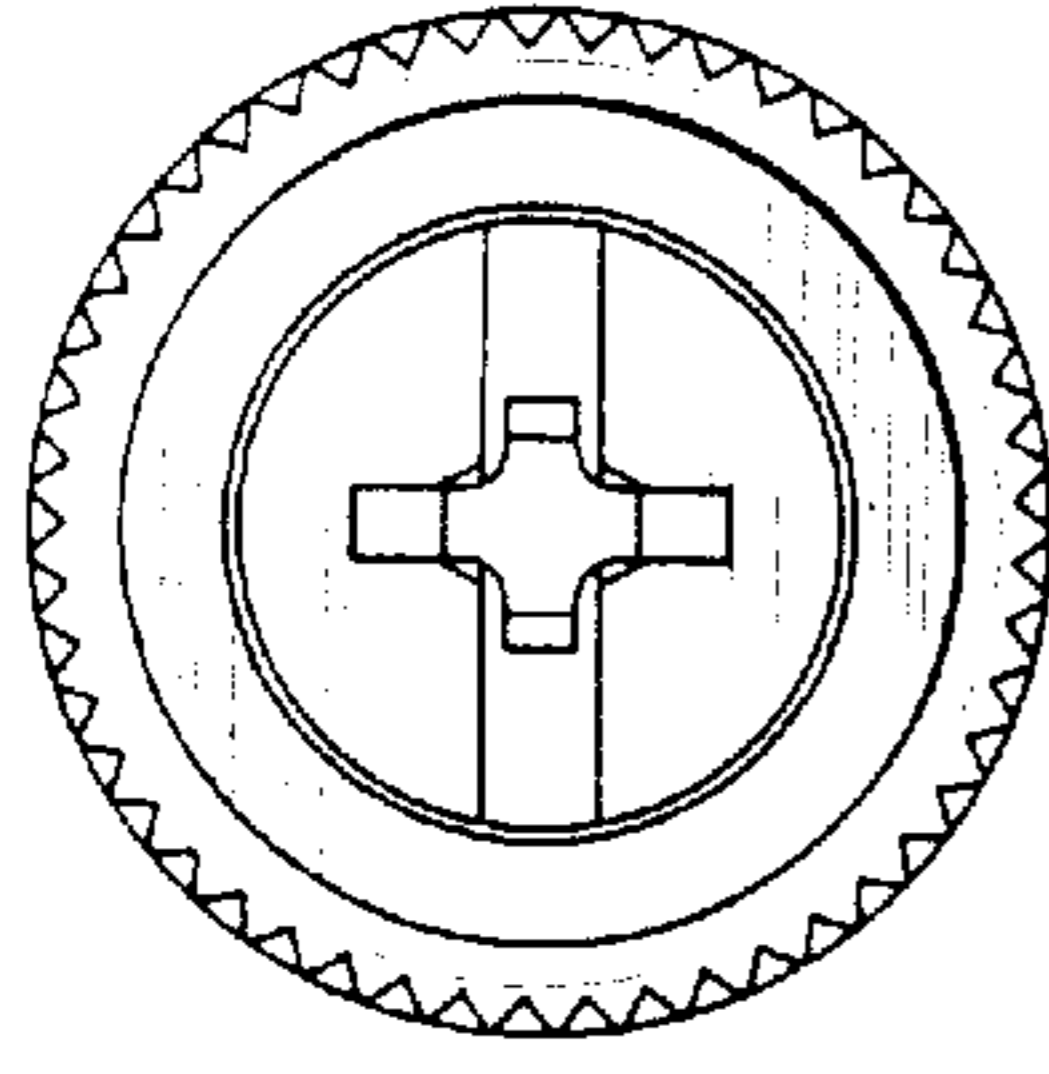

FIG. 24

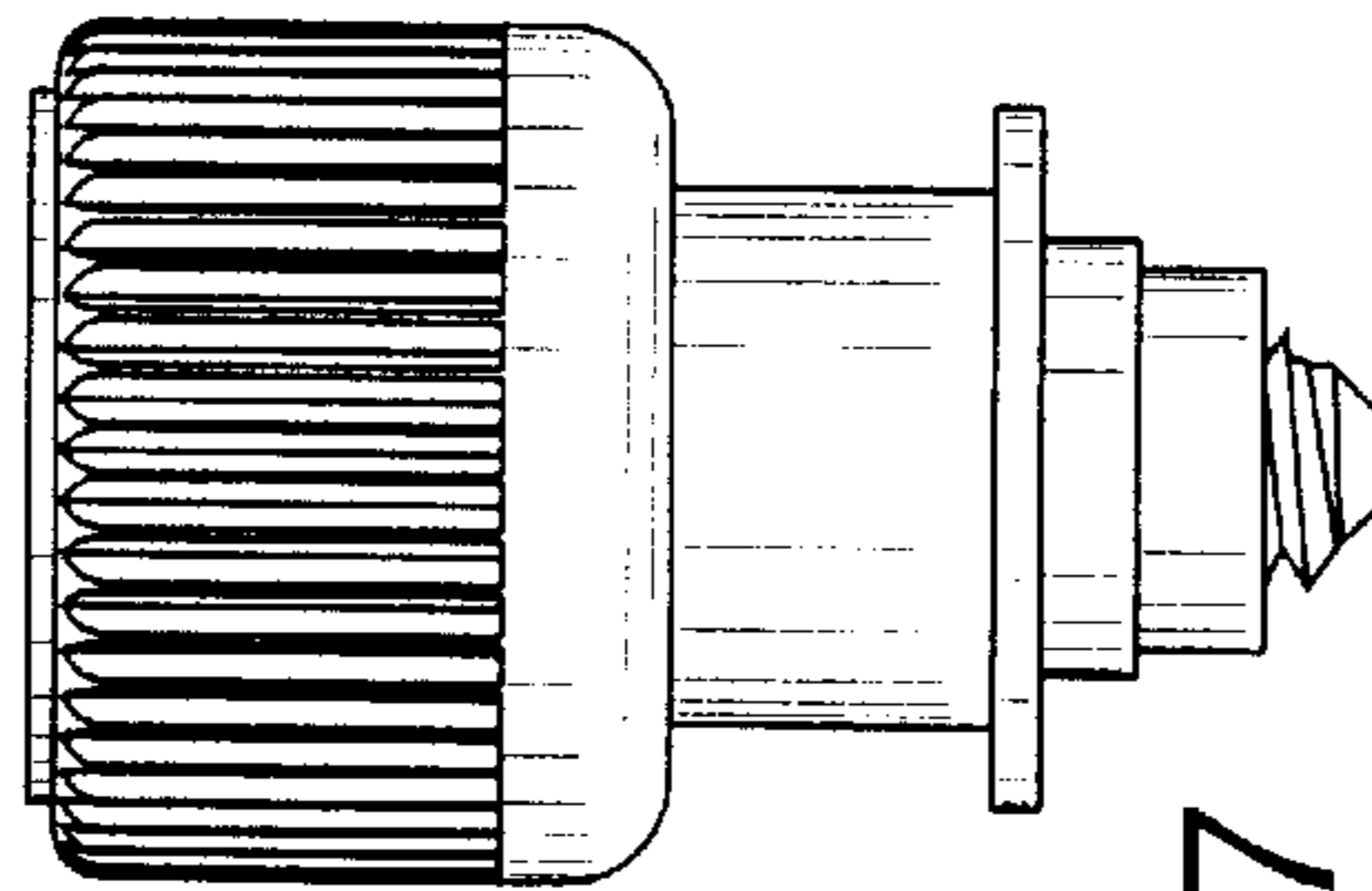

FIG. 17

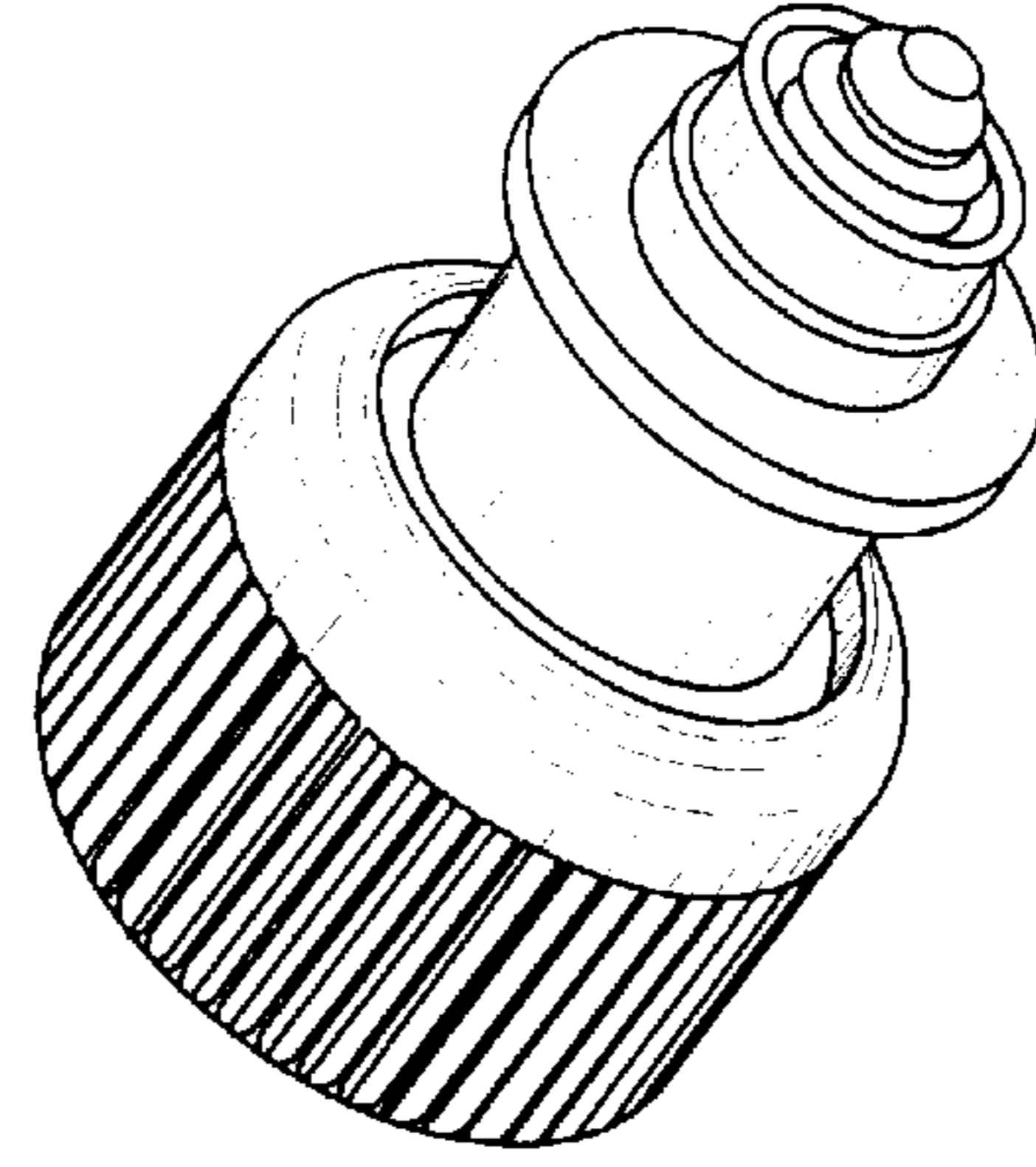

FIG. 18

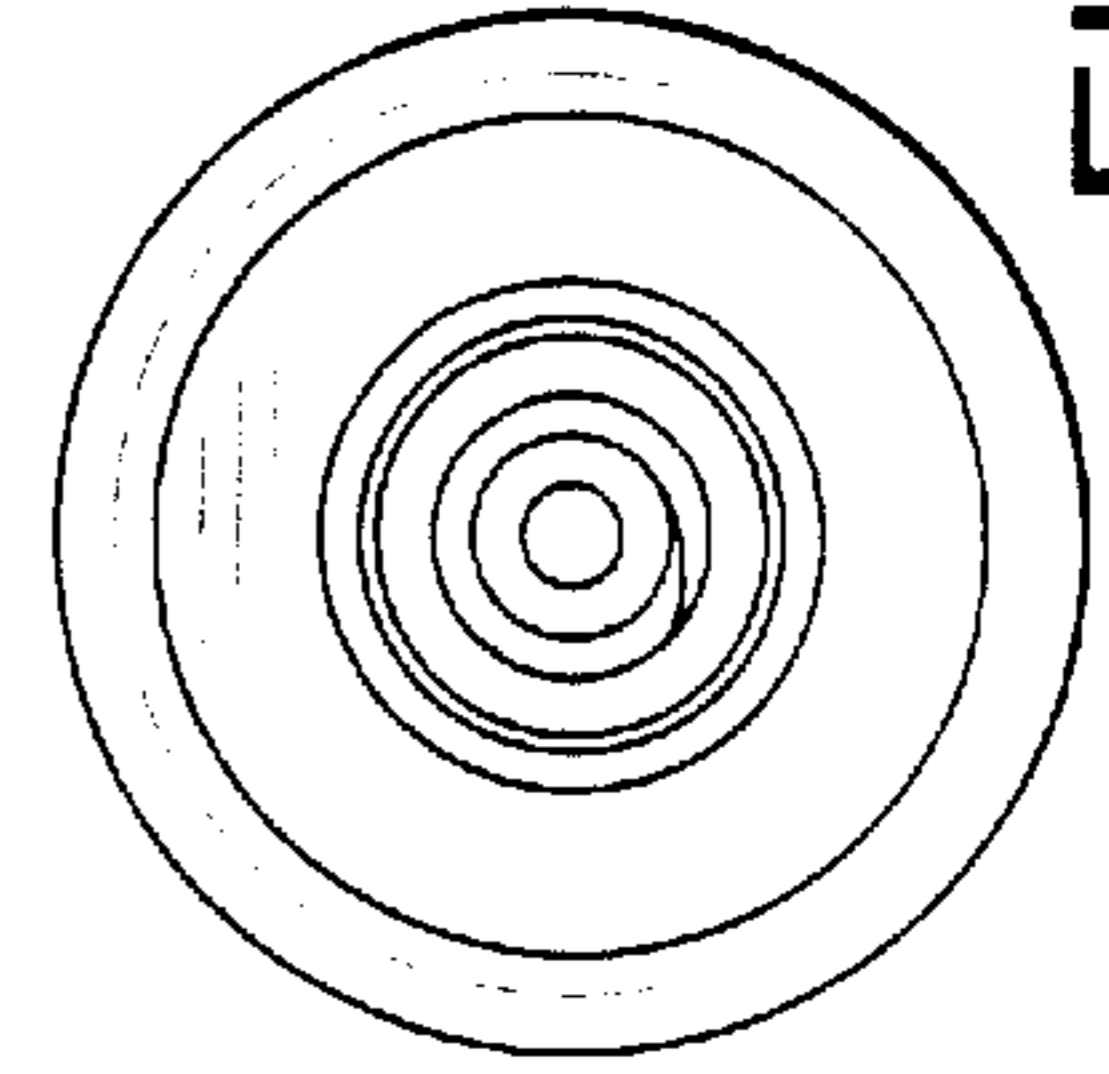

FIG. 19

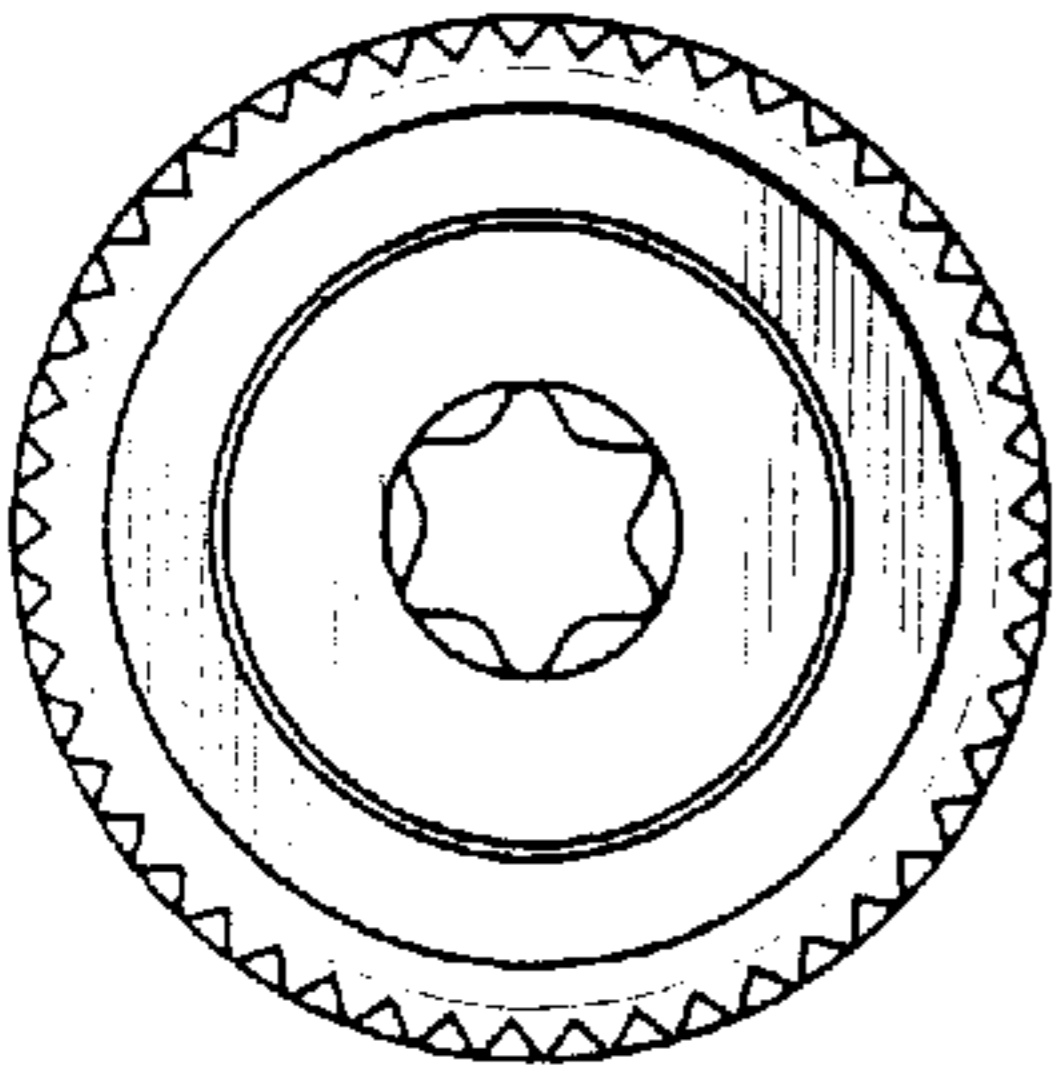

FIG. 28

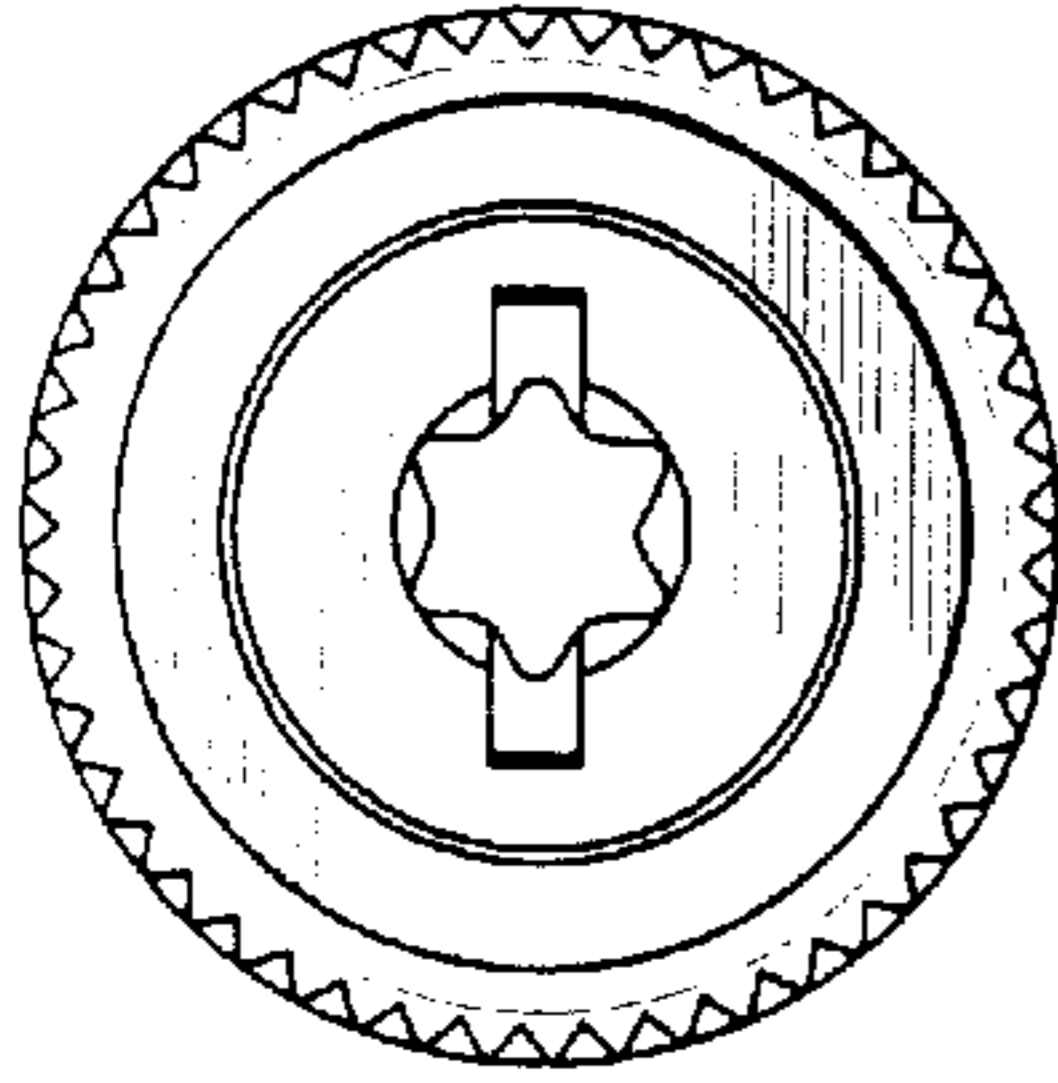

FIG. 29

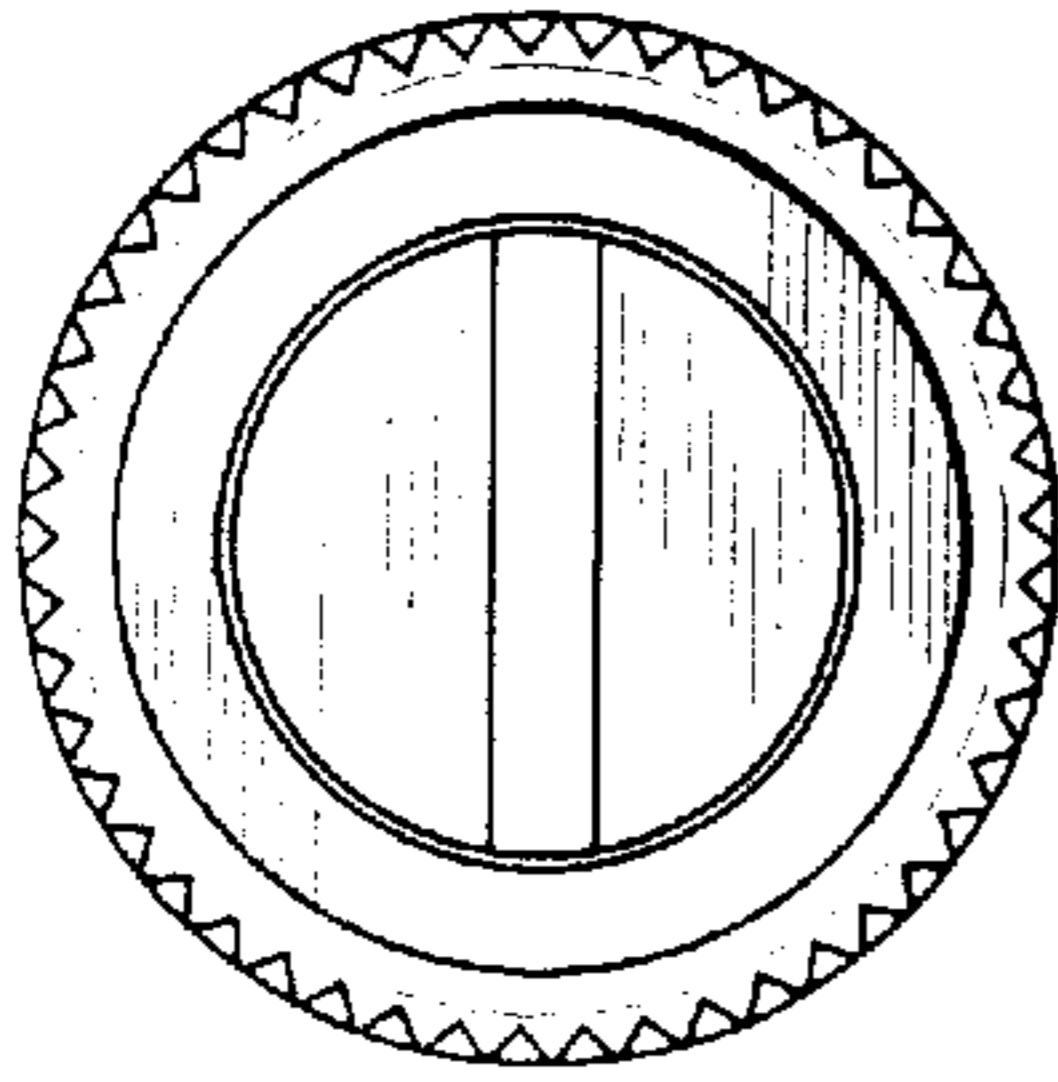

FIG. 30

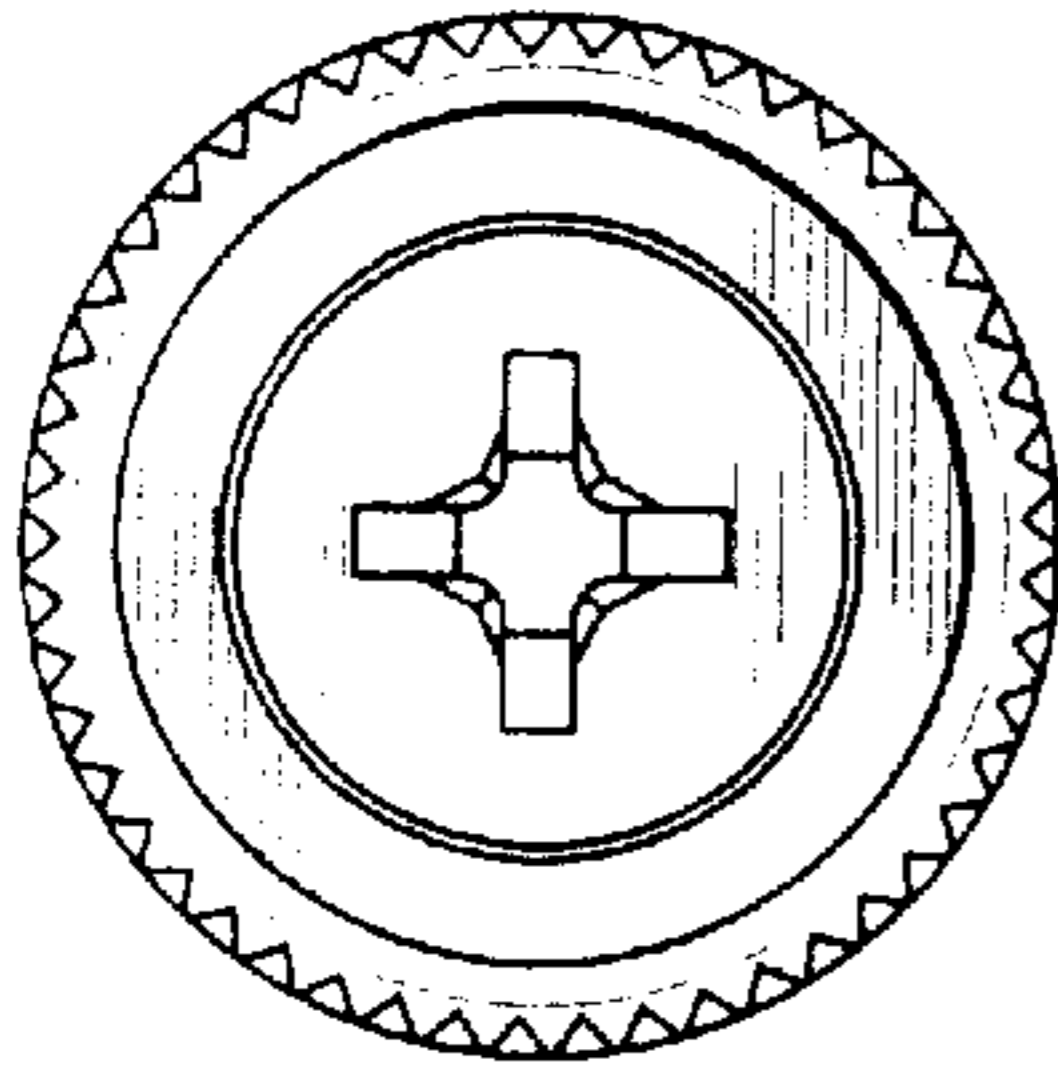

FIG. 31

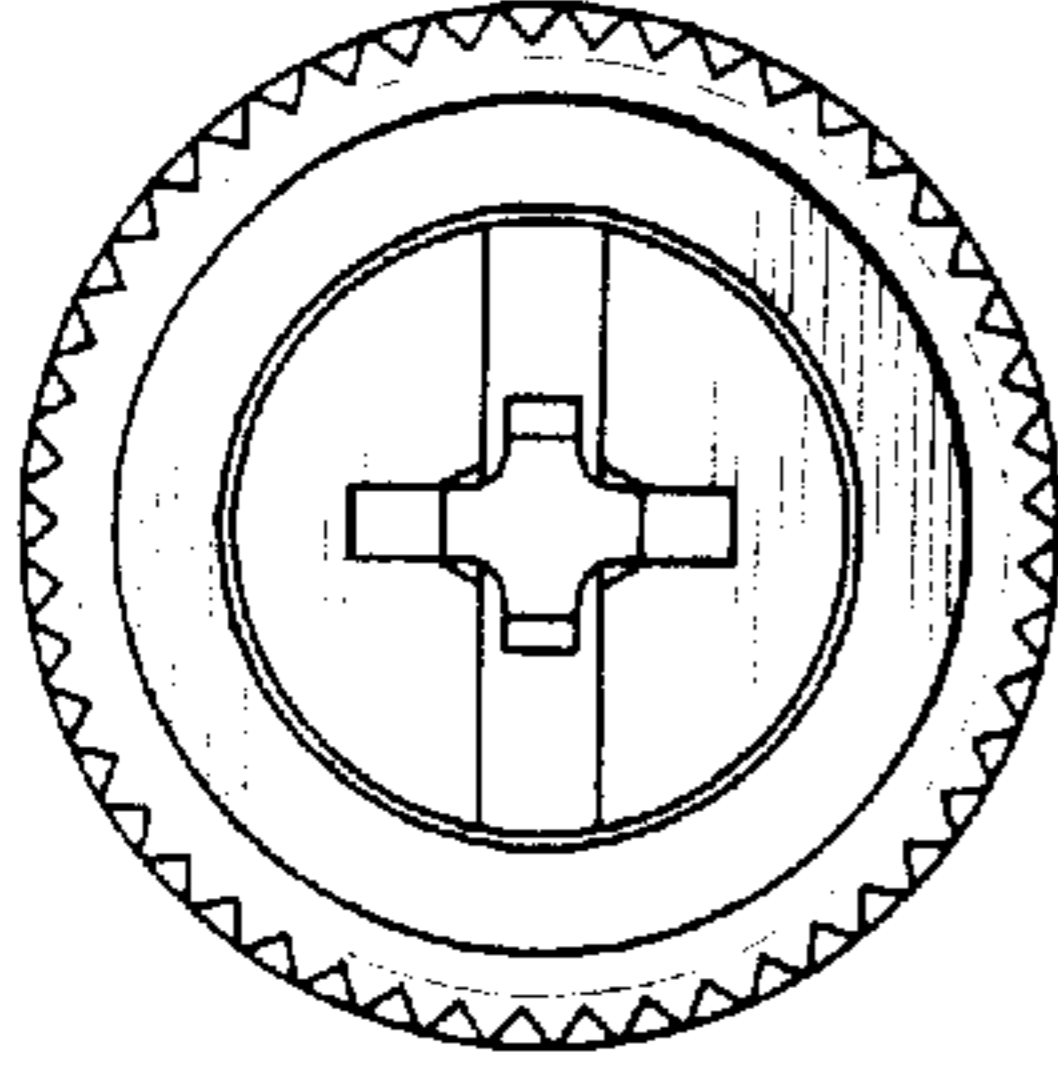

FIG. 32

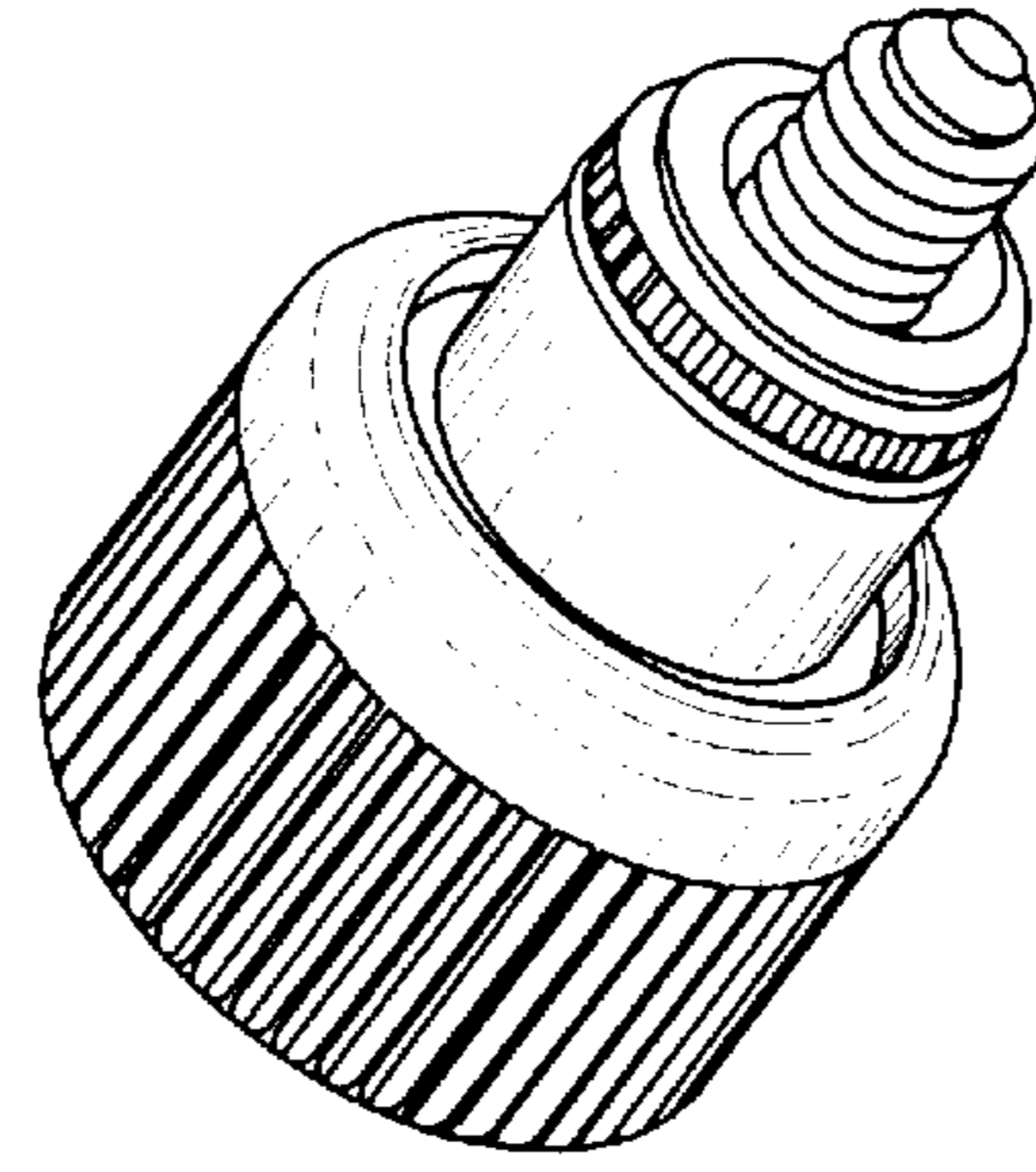

FIG. 26

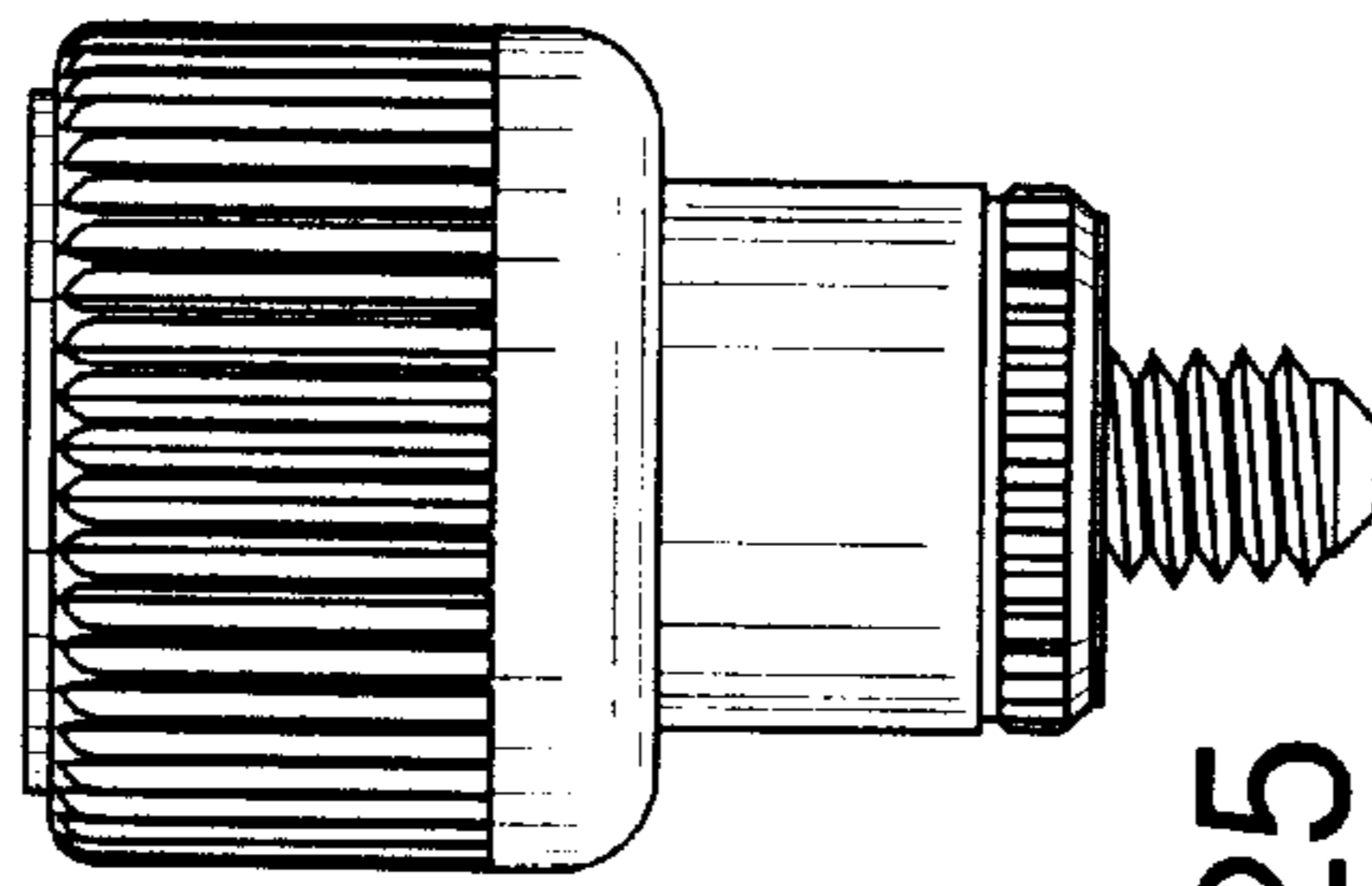

FIG. 25

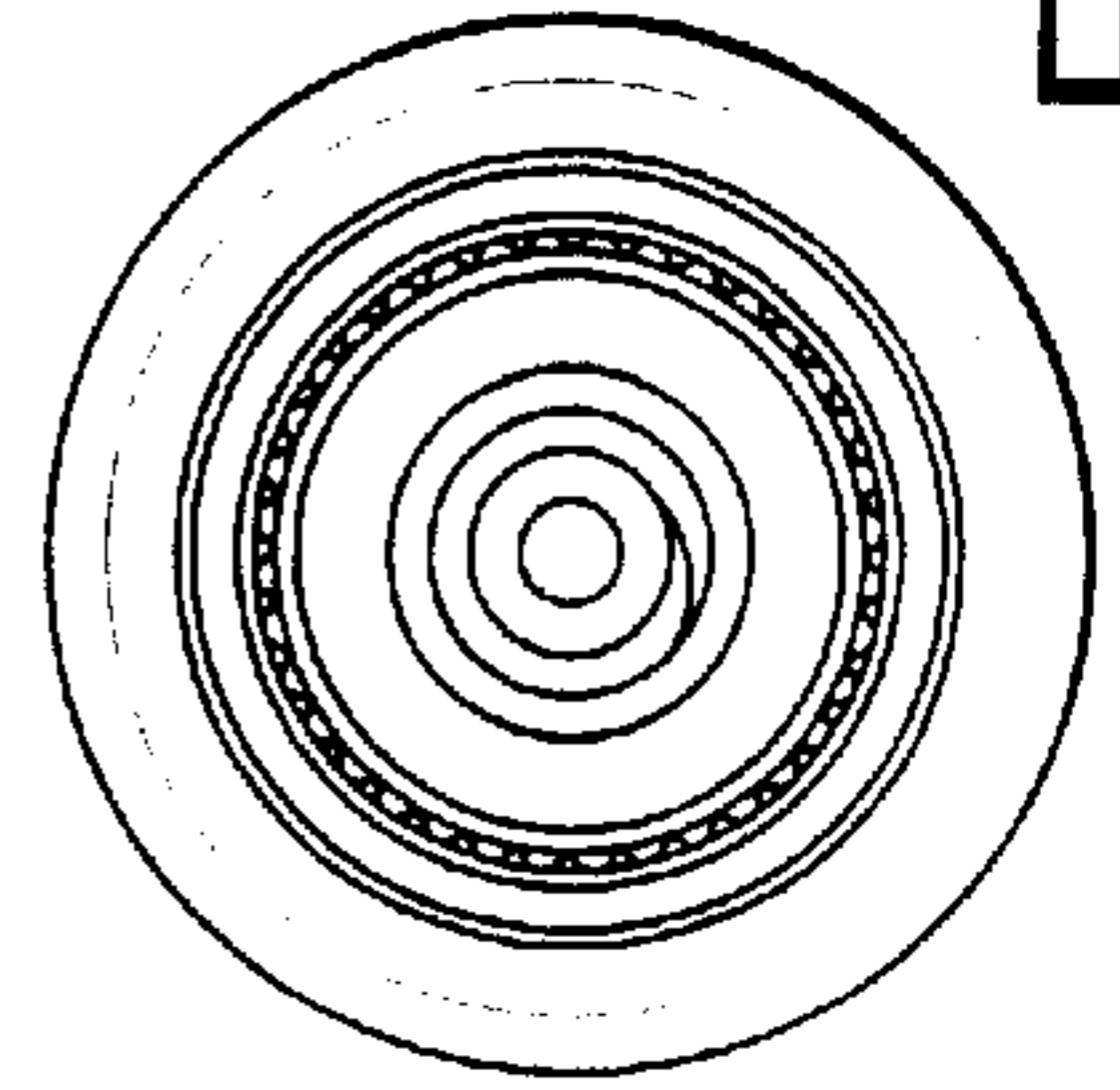

FIG. 27

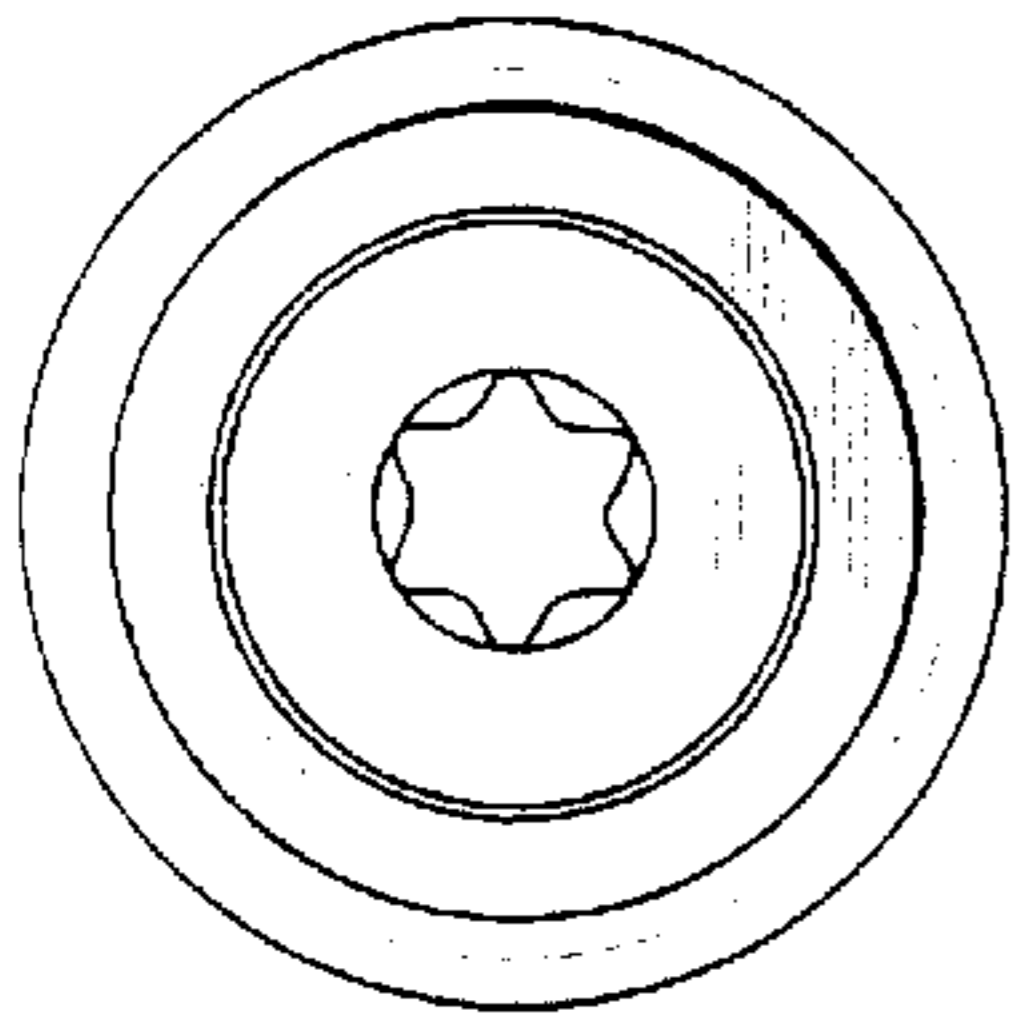

FIG. 36

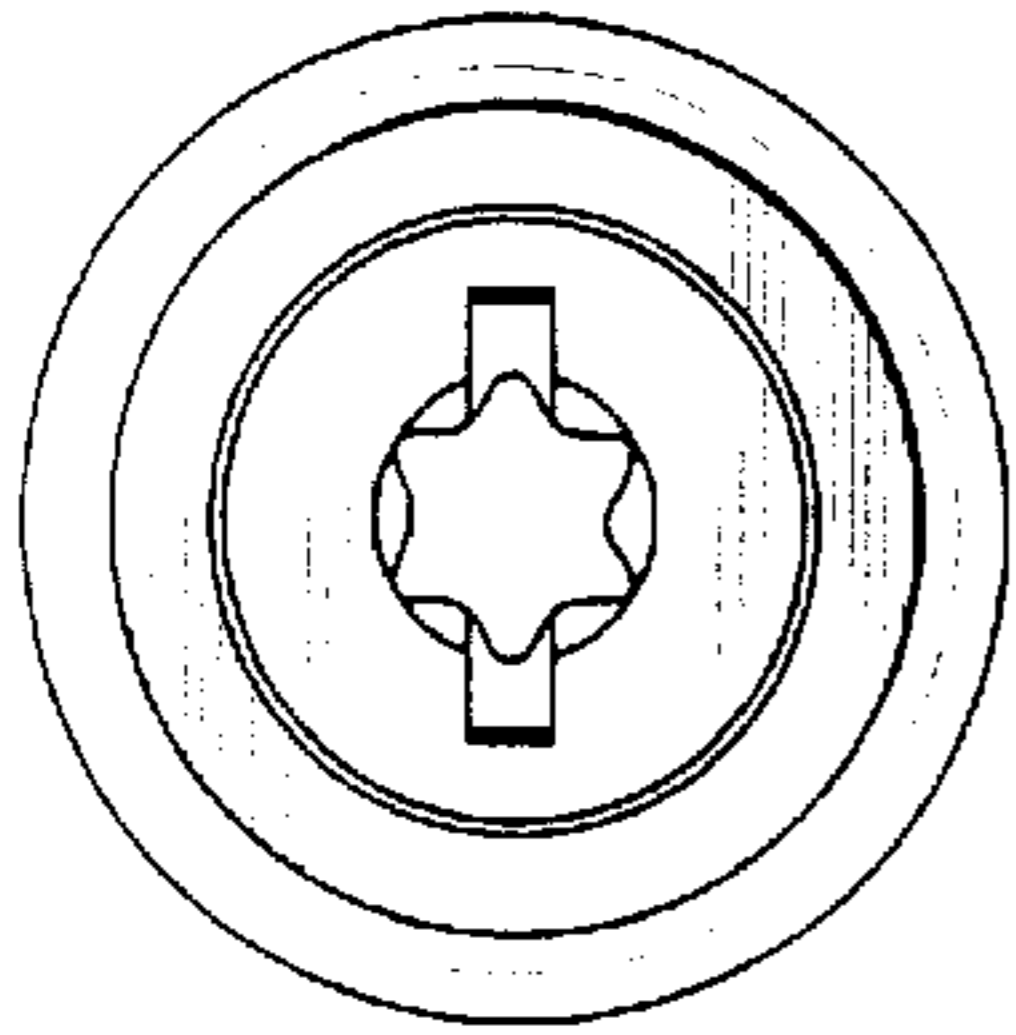

FIG. 37

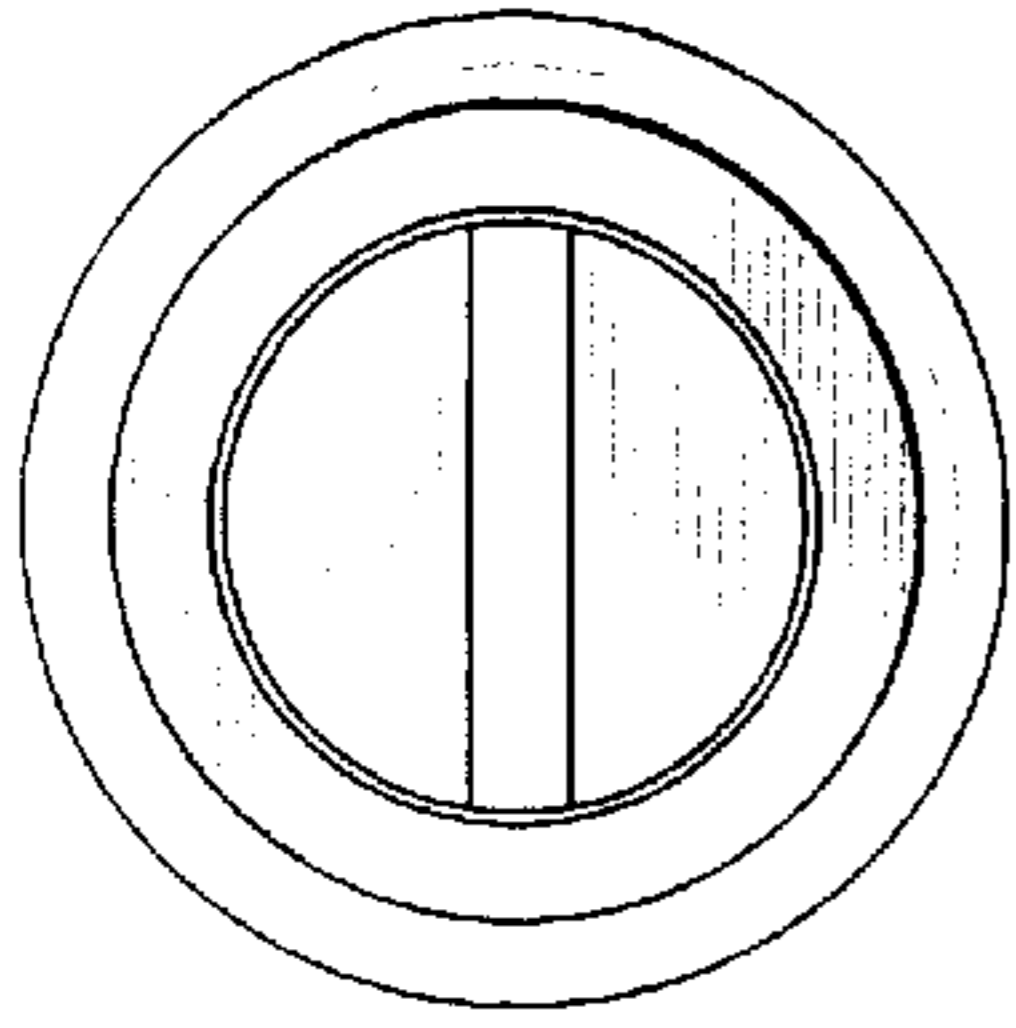

FIG. 38

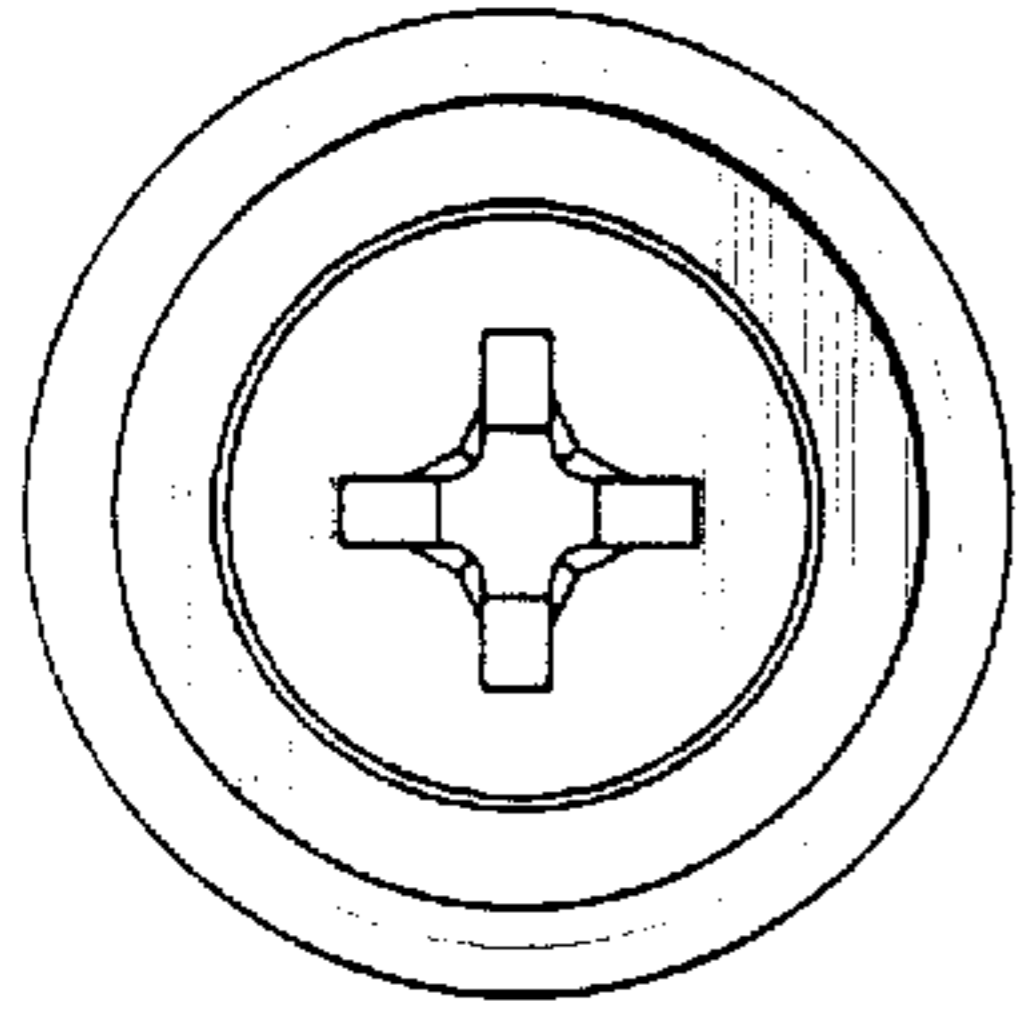

FIG. 39

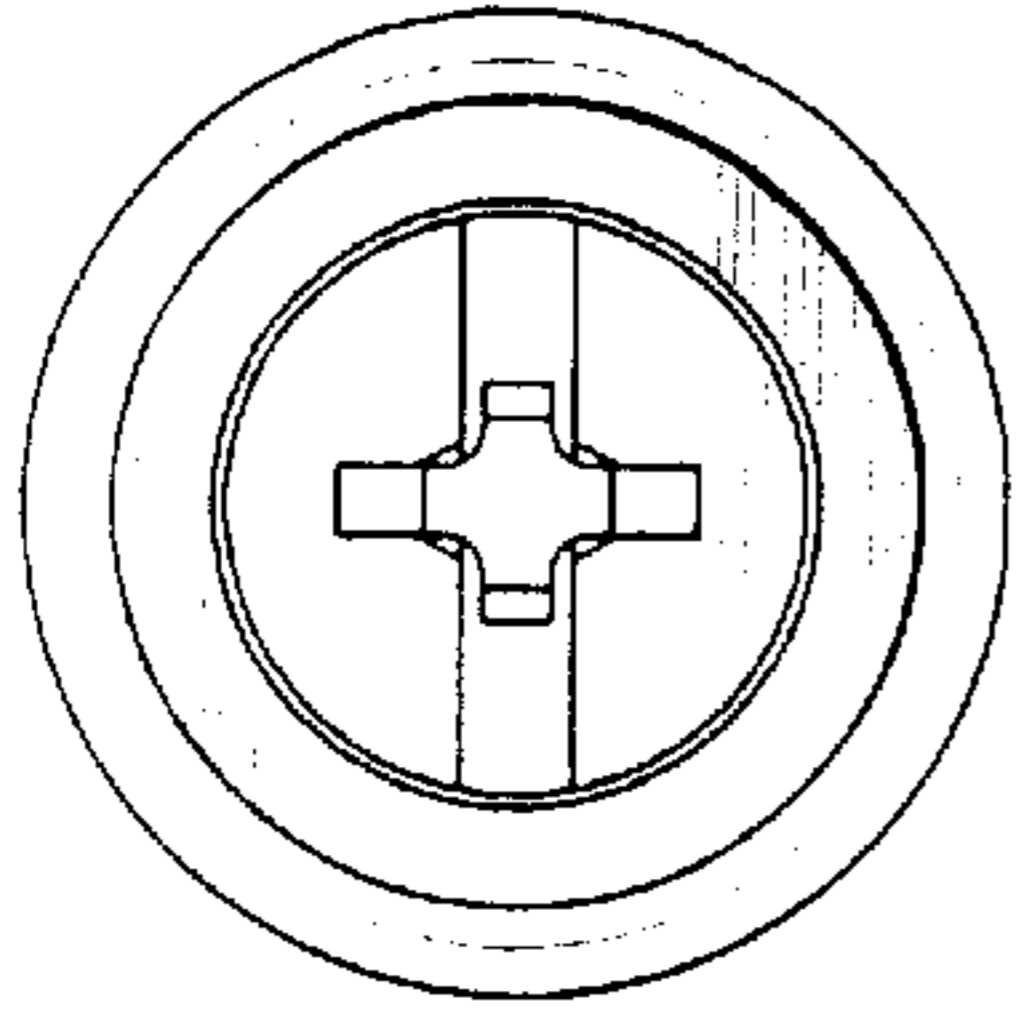

FIG. 40

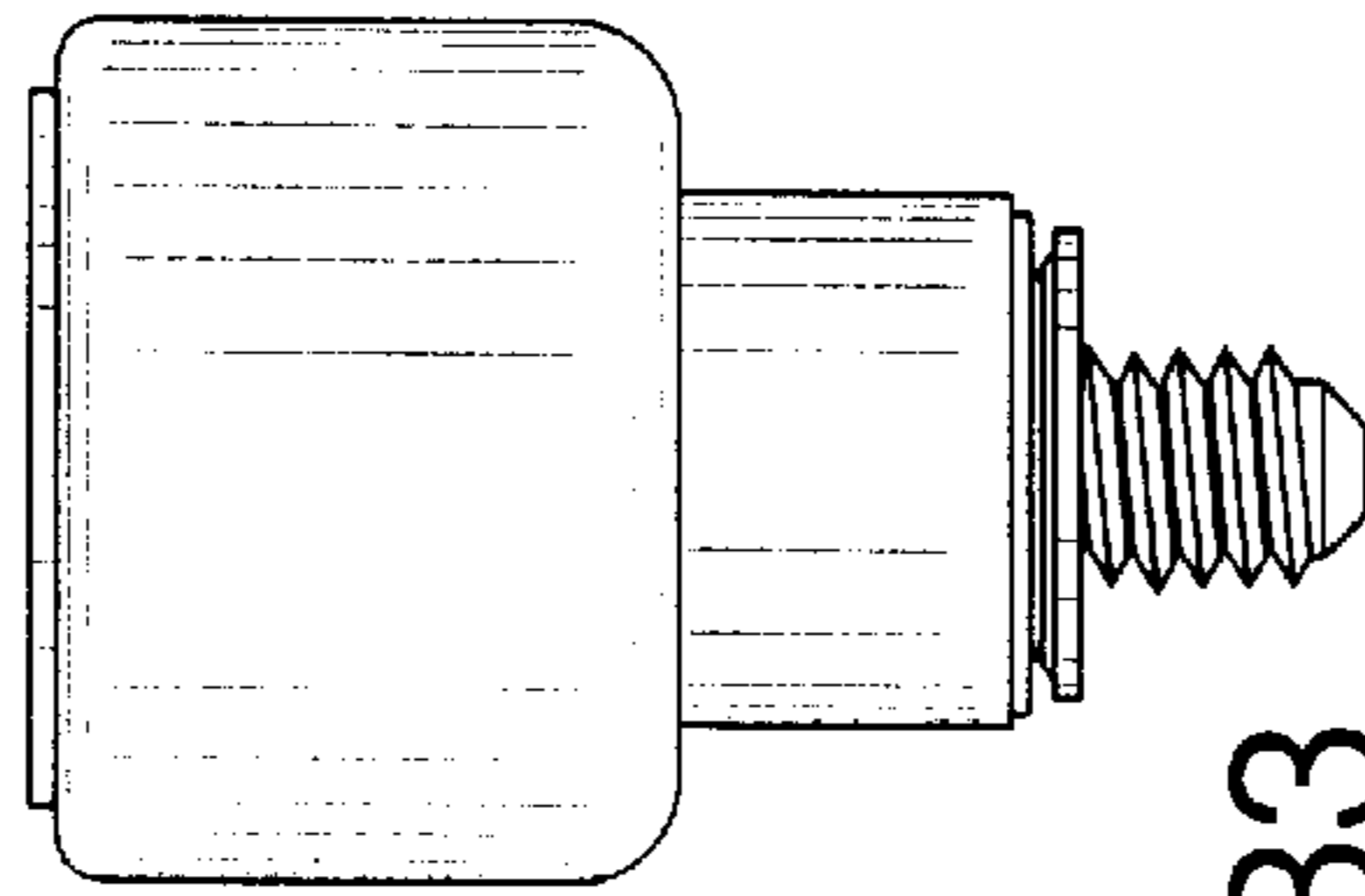

FIG. 33

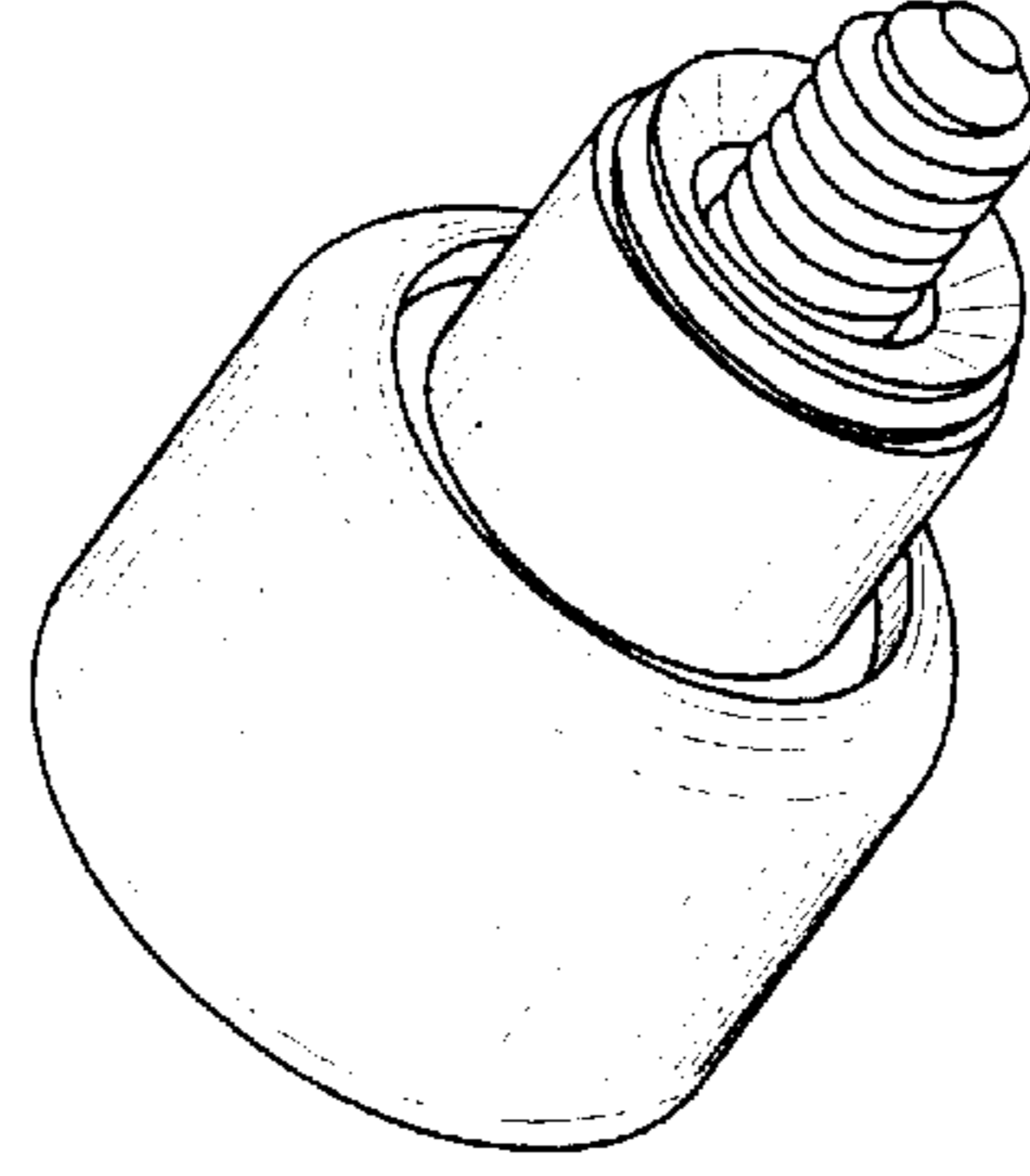

FIG. 34

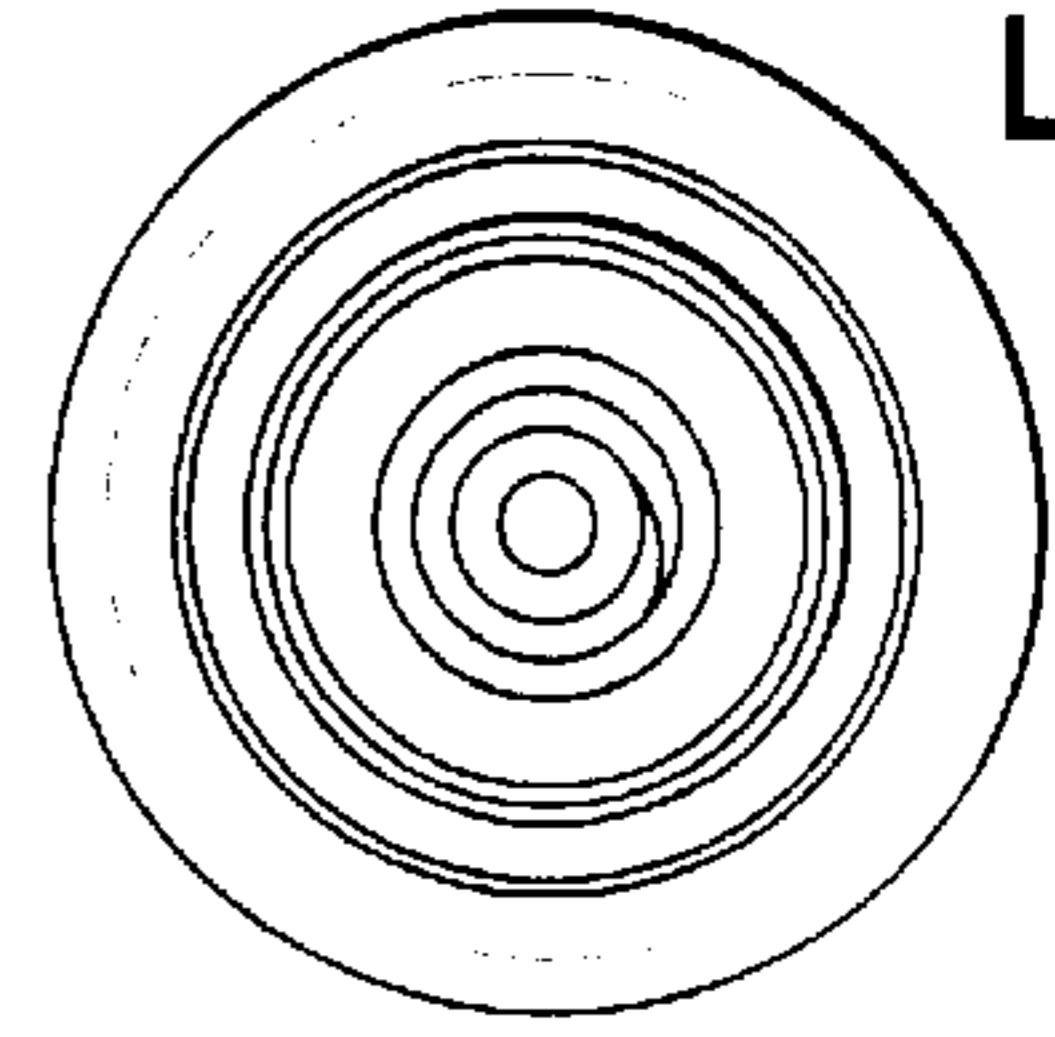

FIG. 35

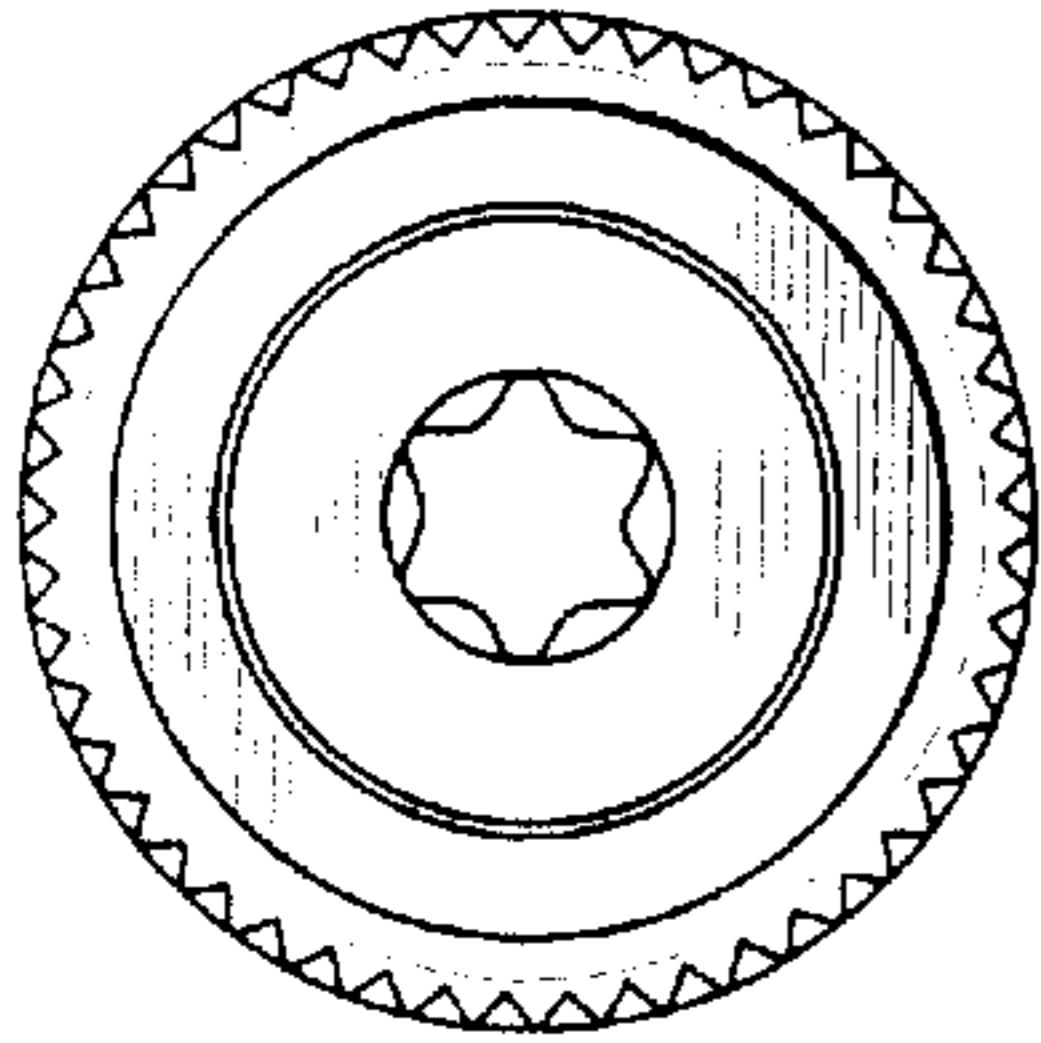

FIG. 44

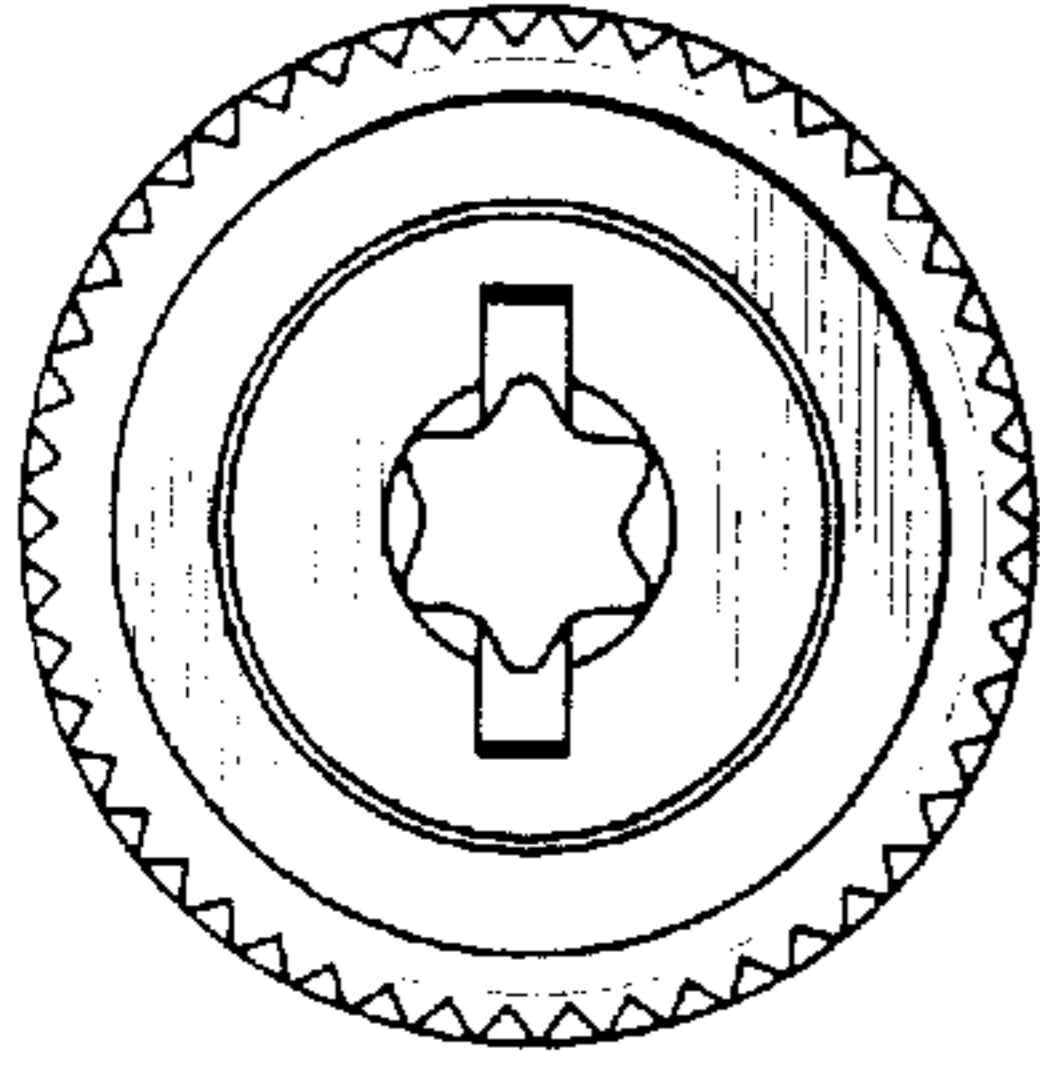

FIG. 45

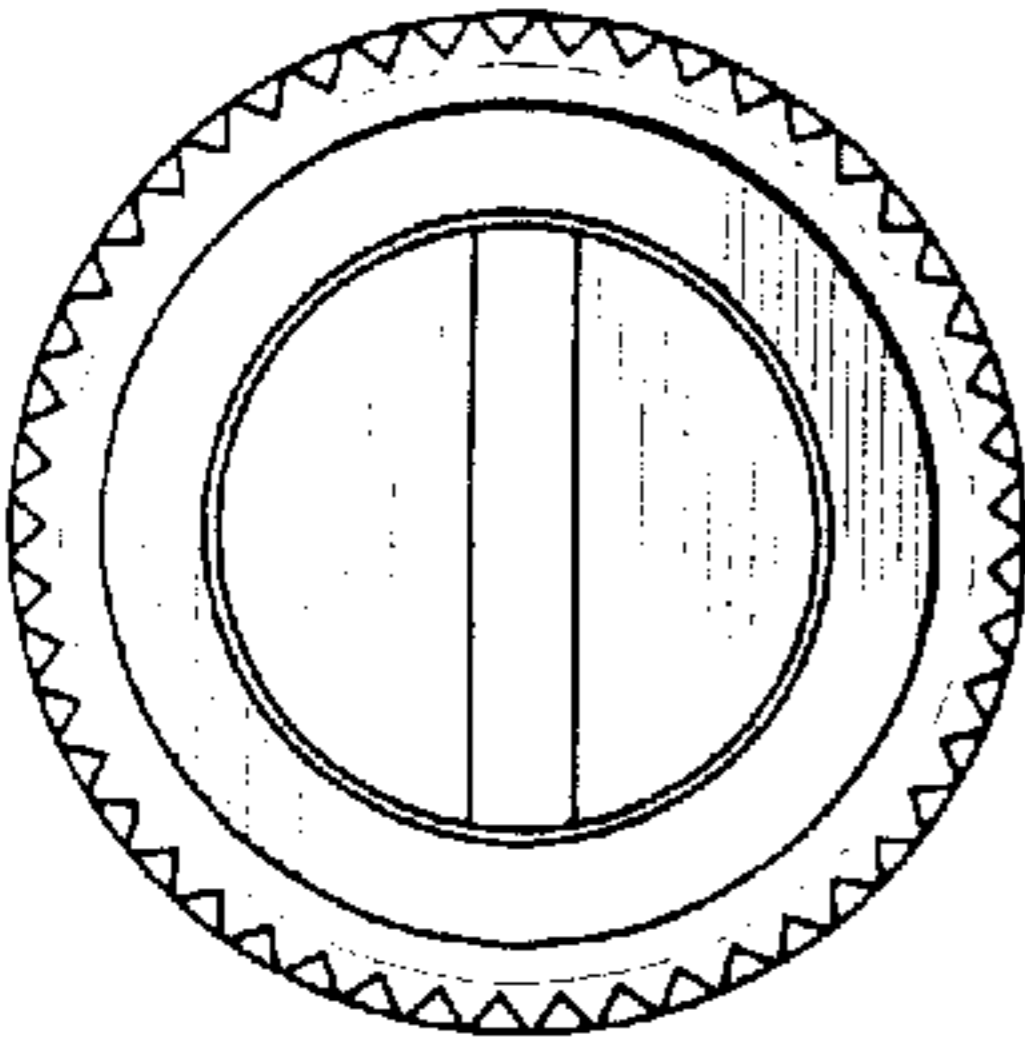

FIG. 46

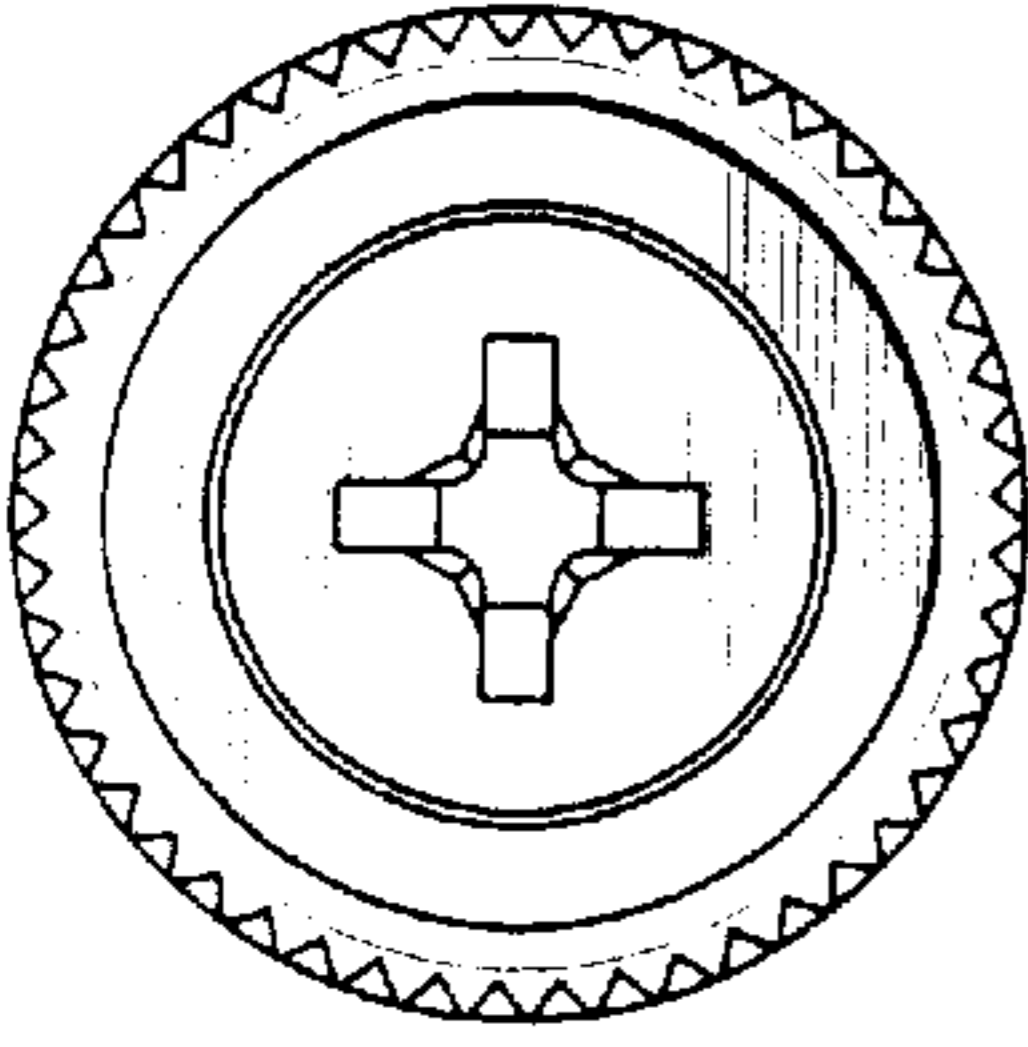

FIG. 47

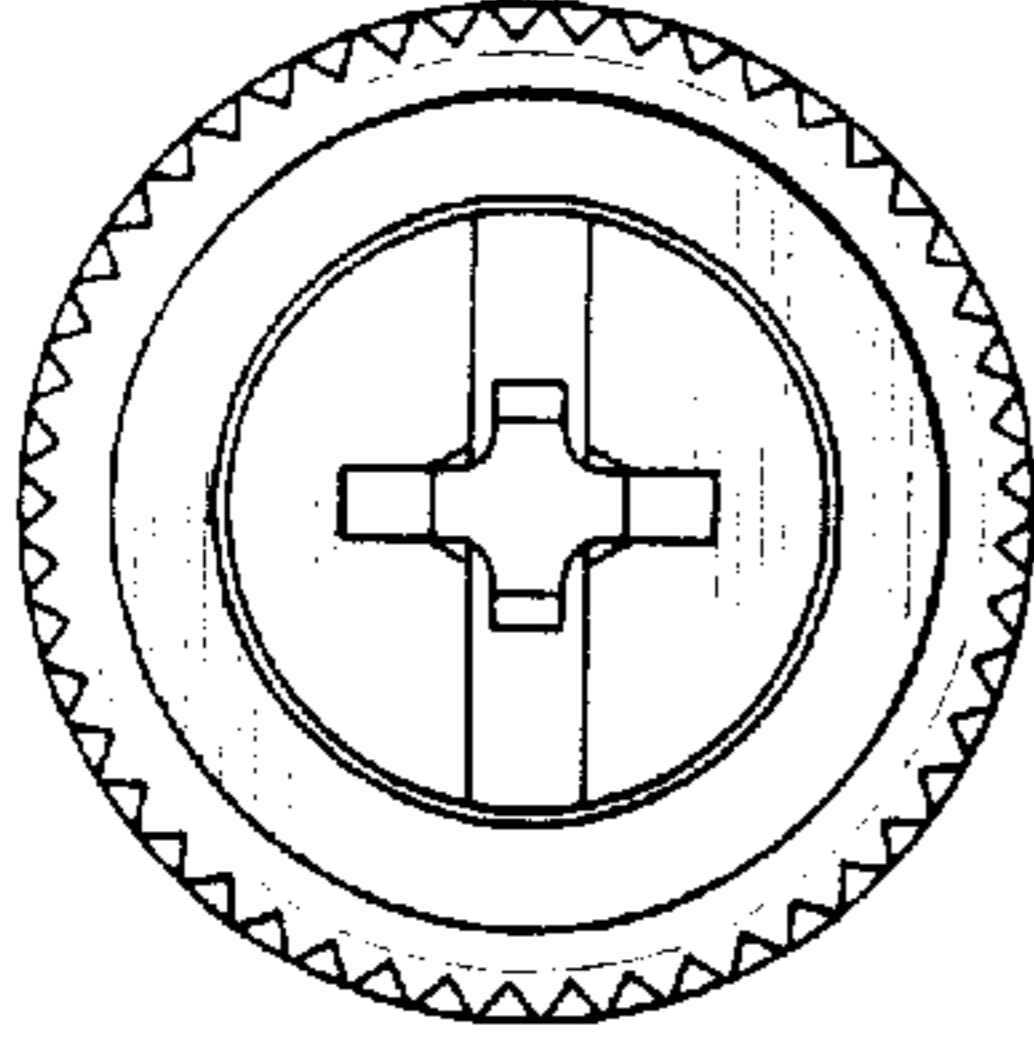

FIG. 48

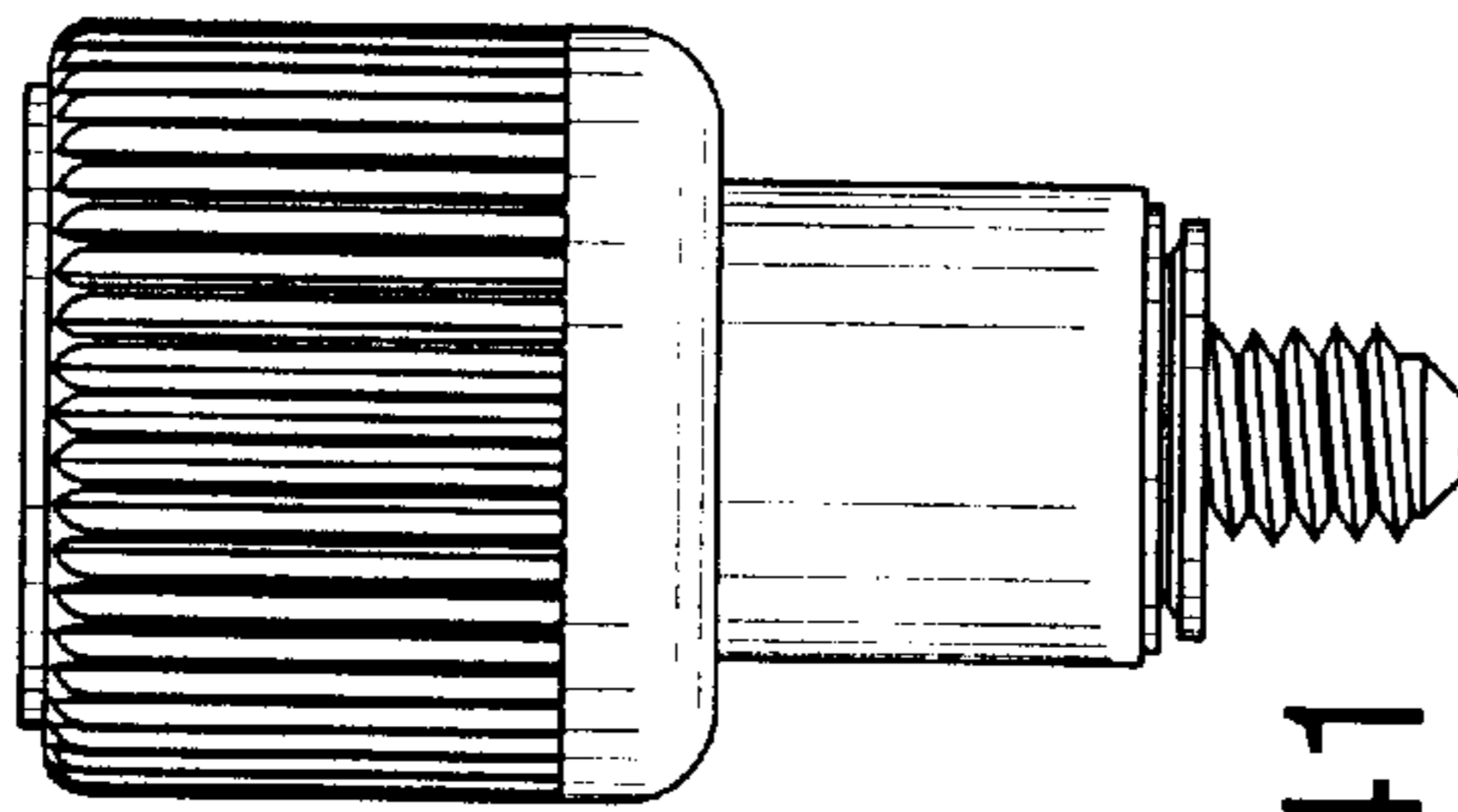

FIG. 41

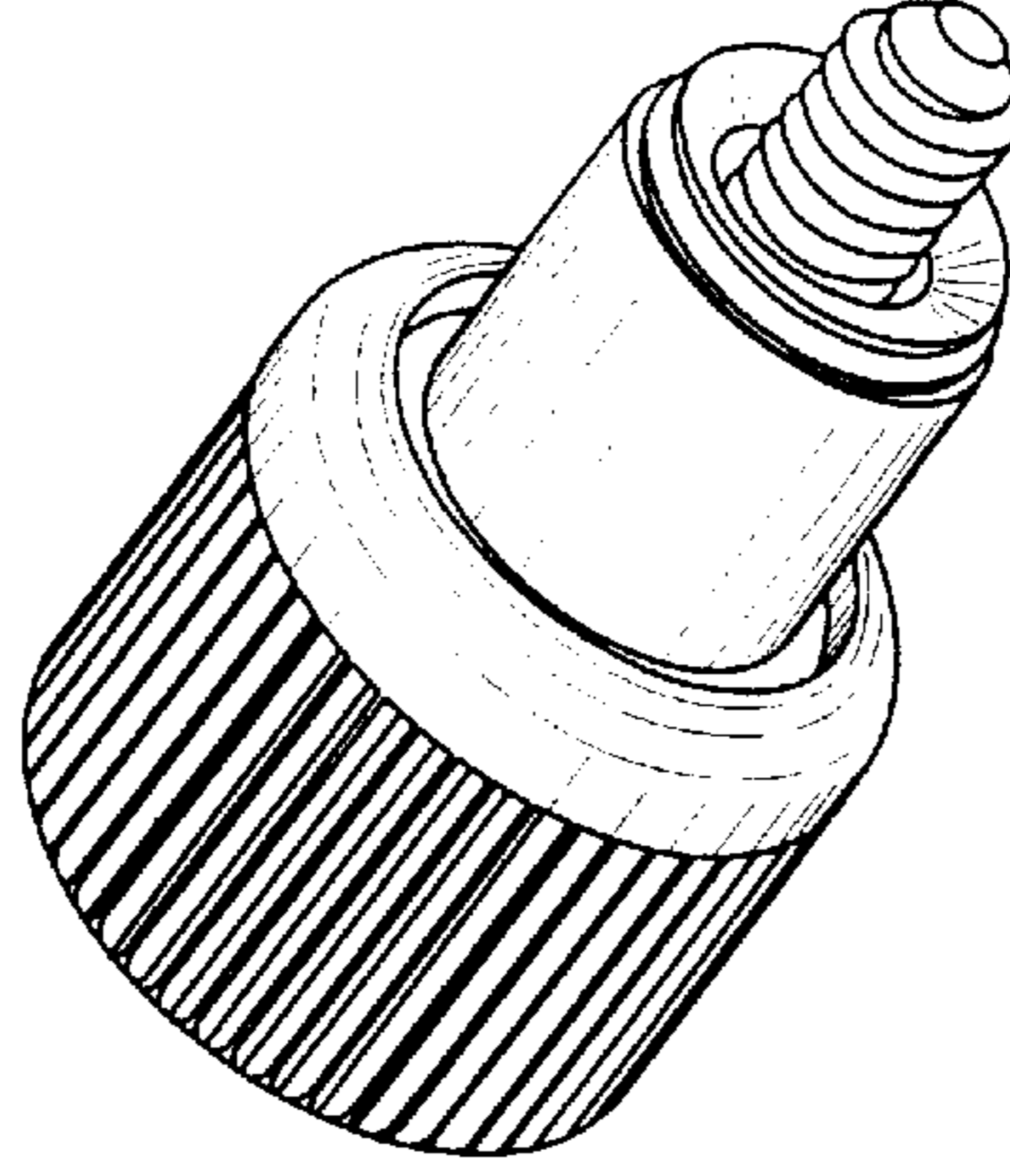

FIG. 42

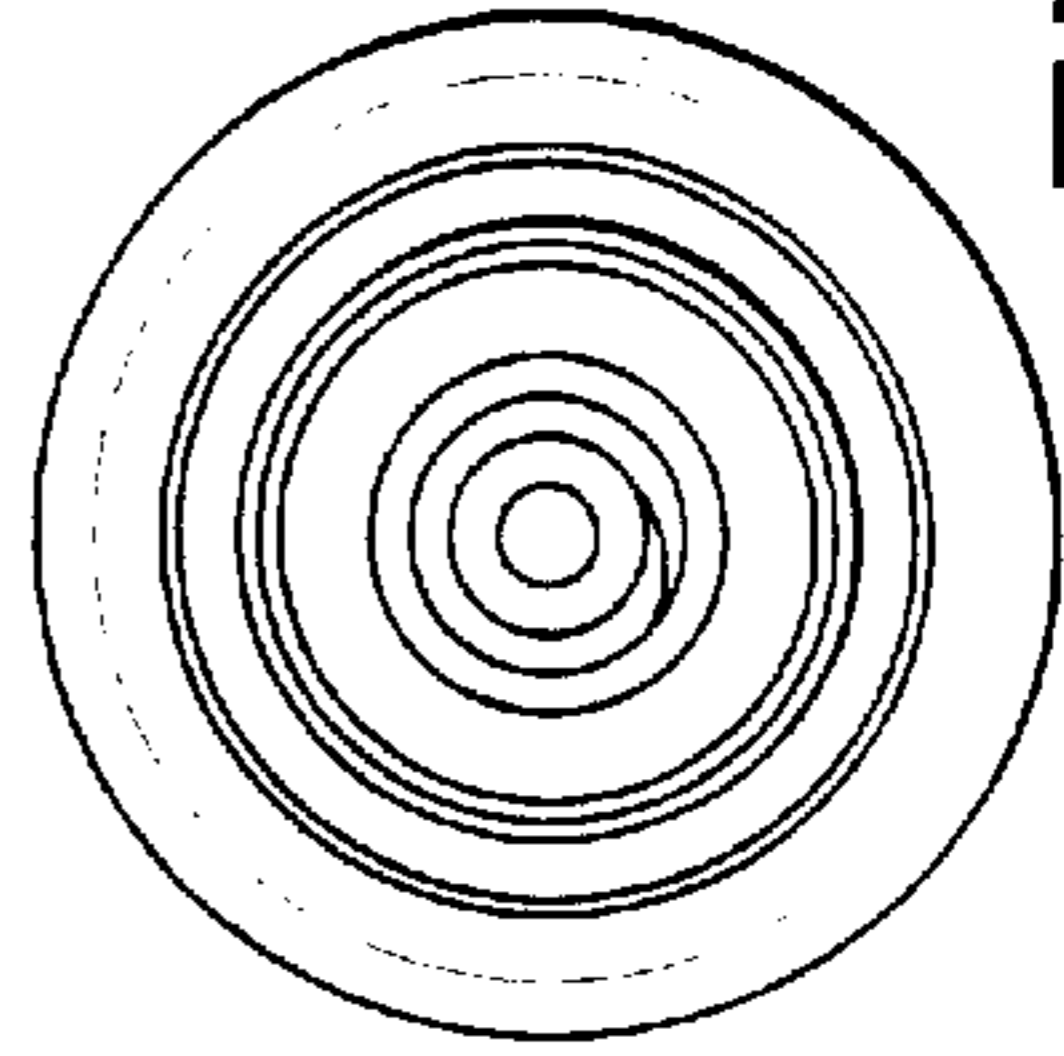

FIG. 43

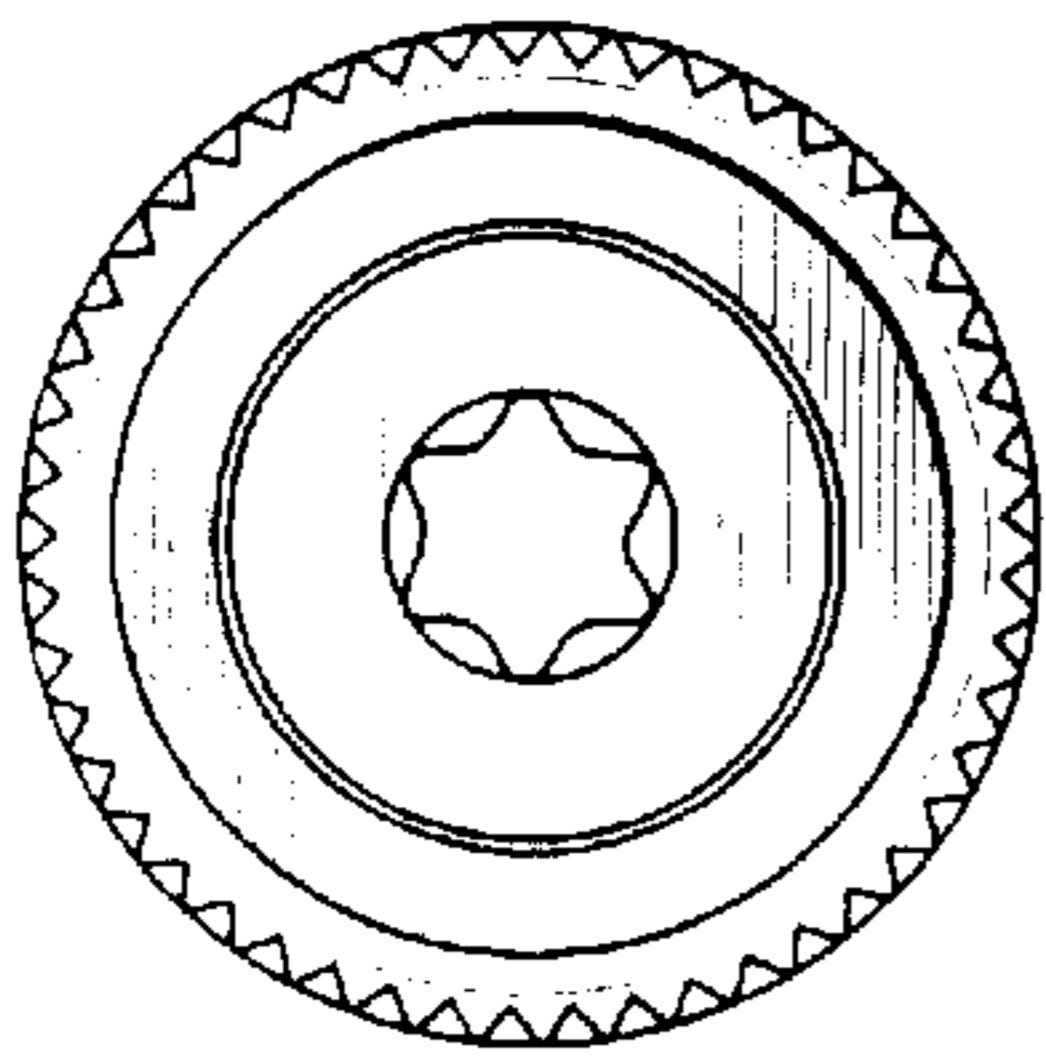

FIG. 52

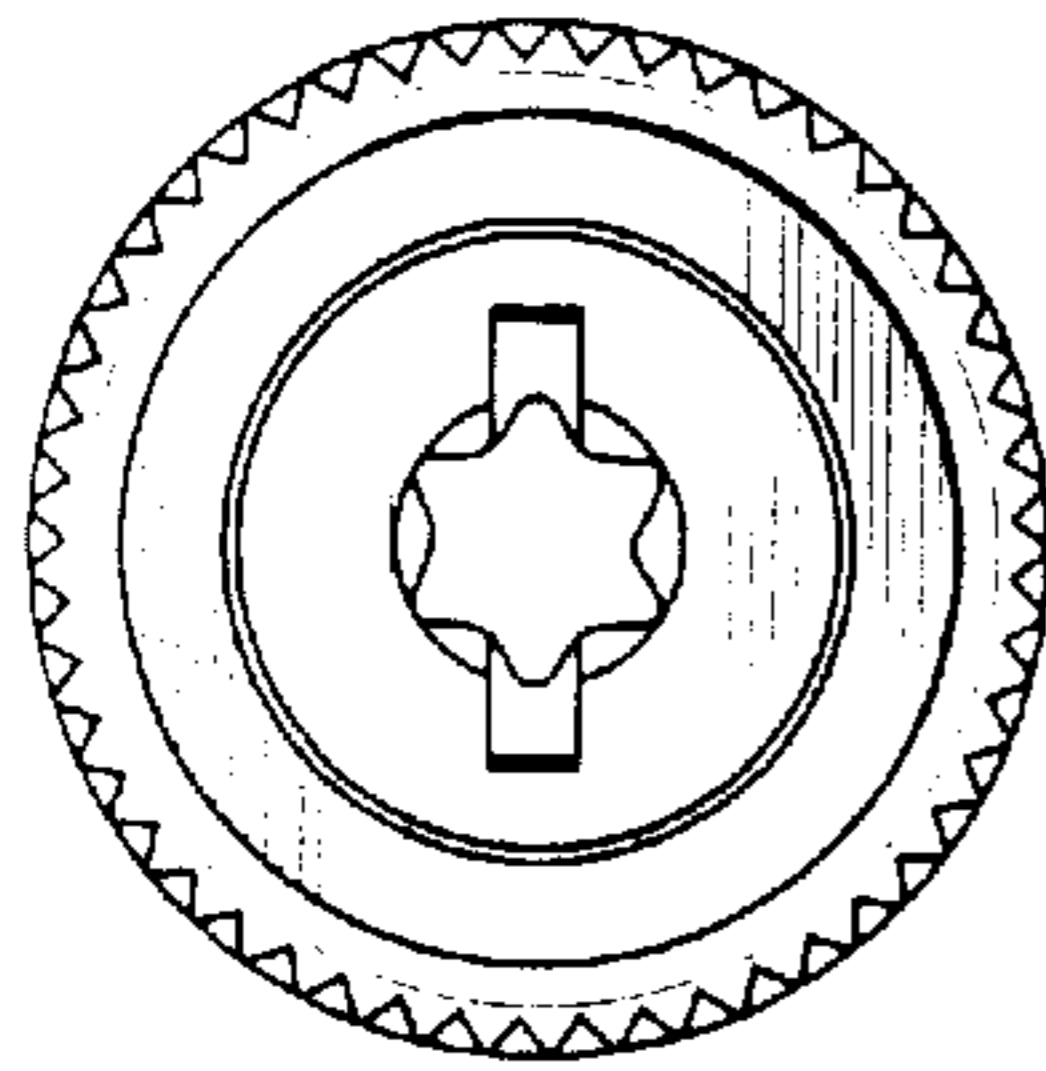

FIG. 53

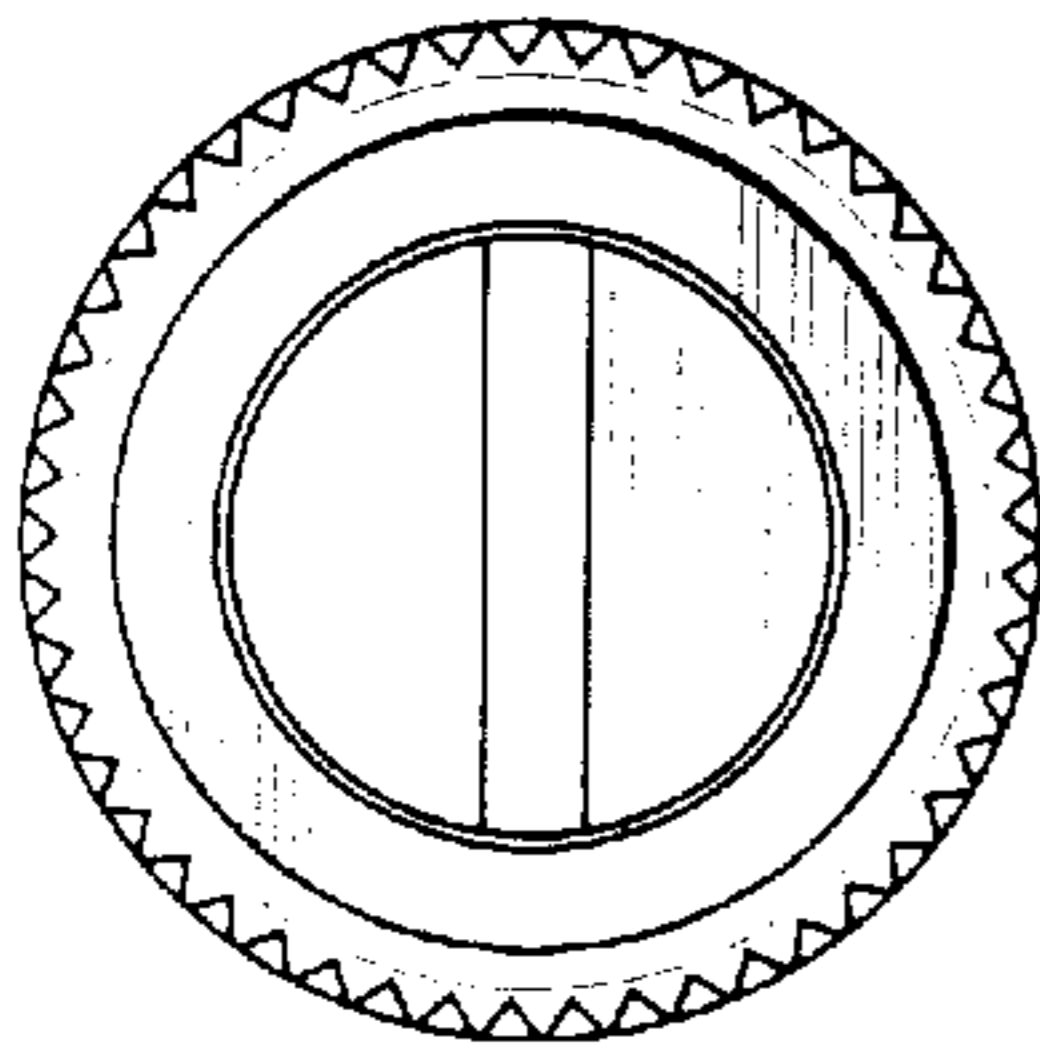

FIG. 54

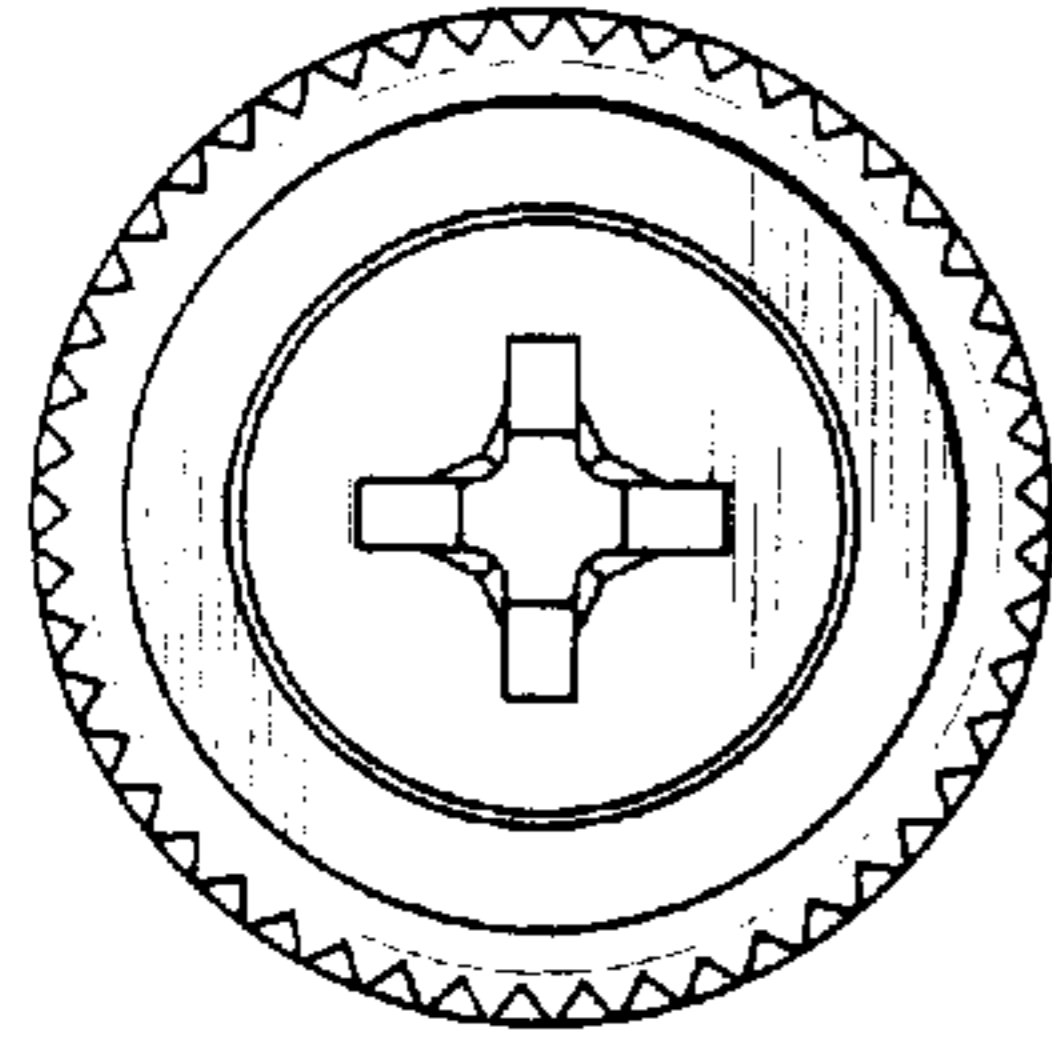

FIG. 55

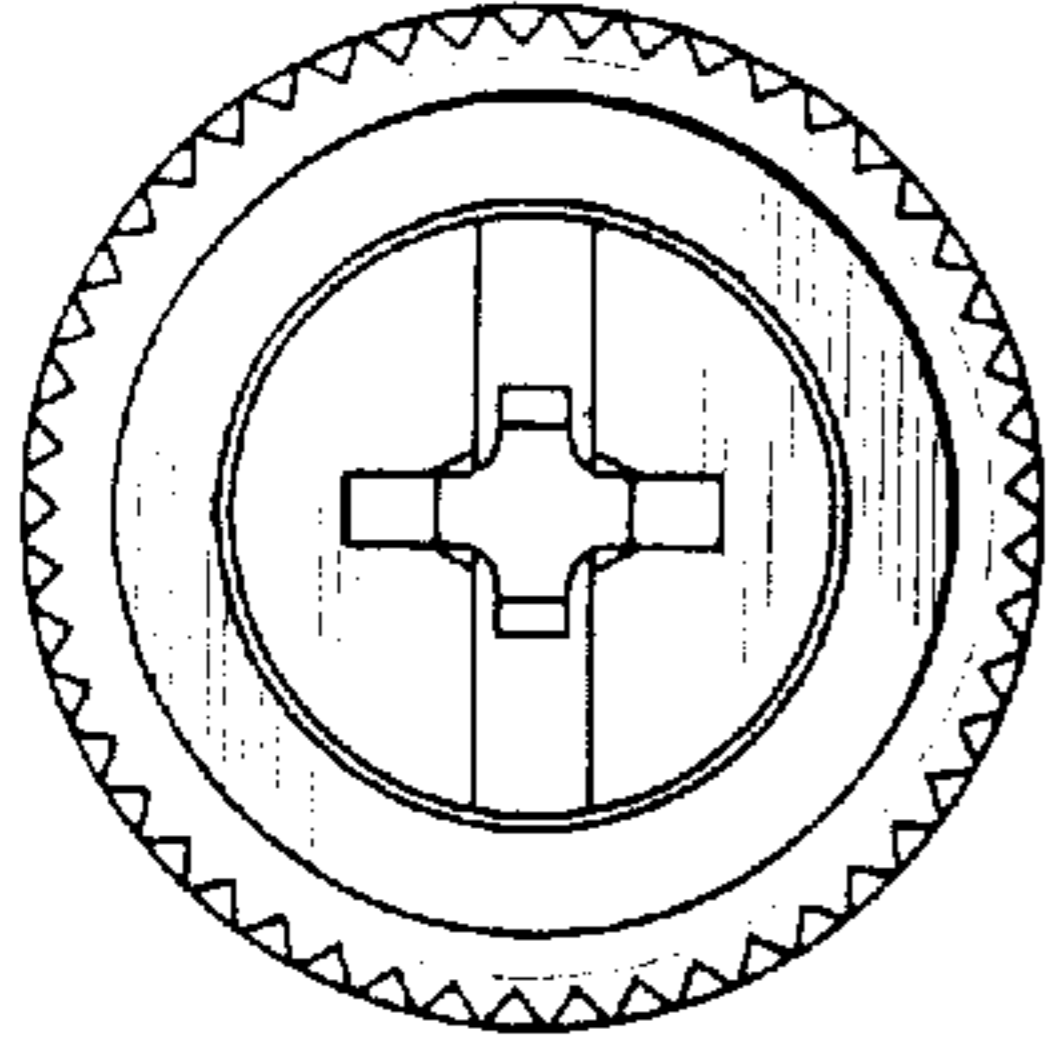

FIG. 56

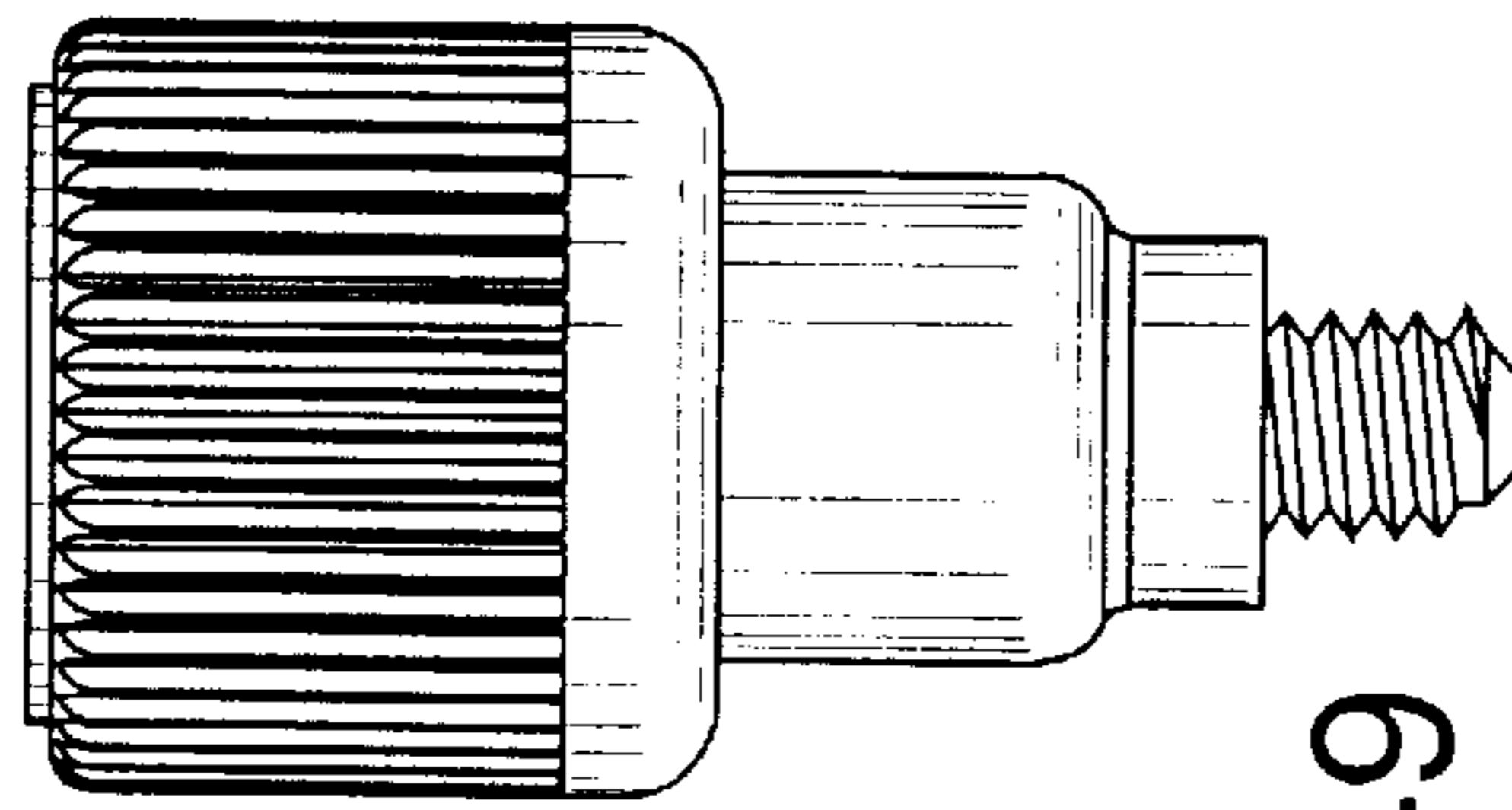

FIG. 49

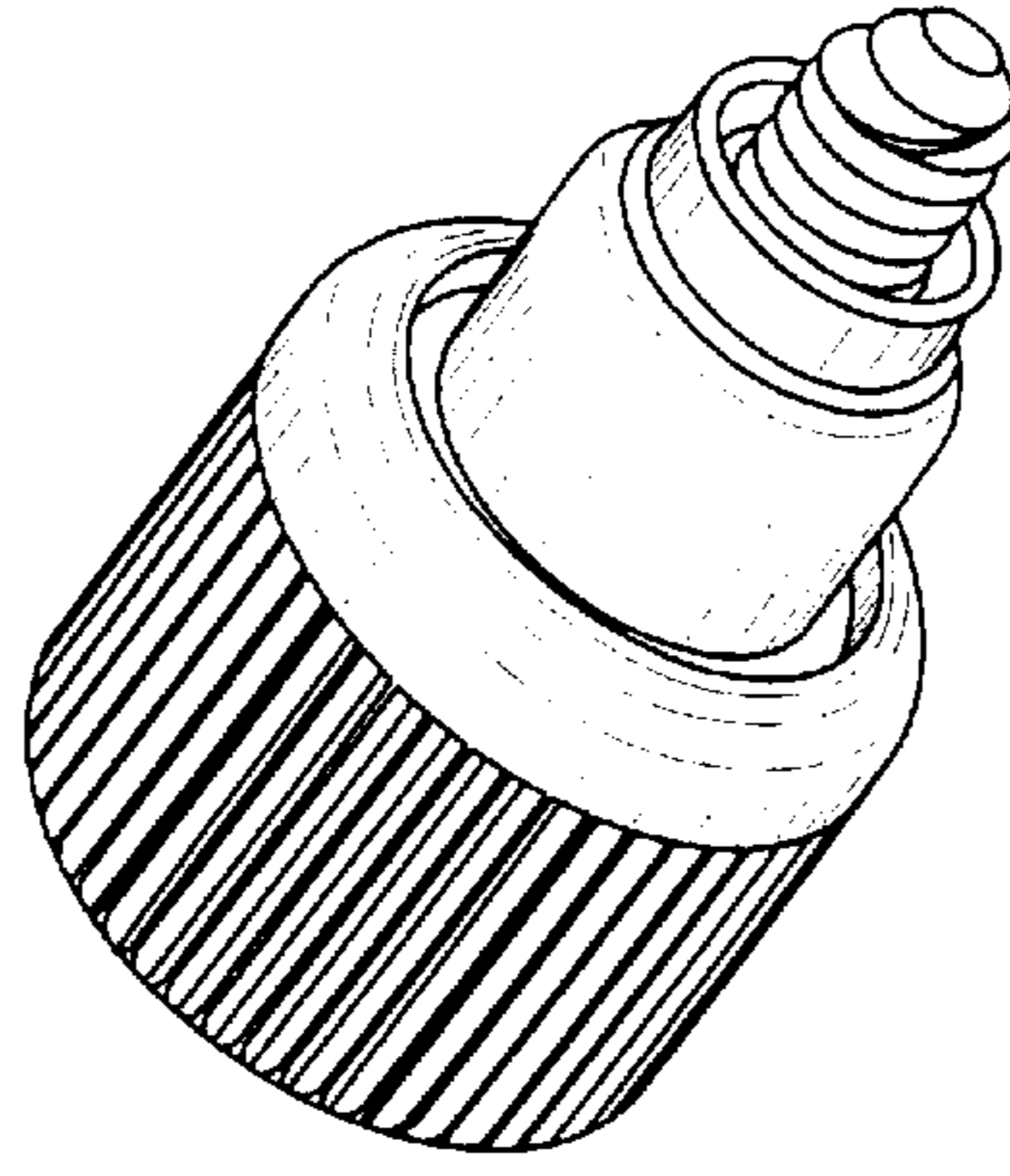

FIG. 50

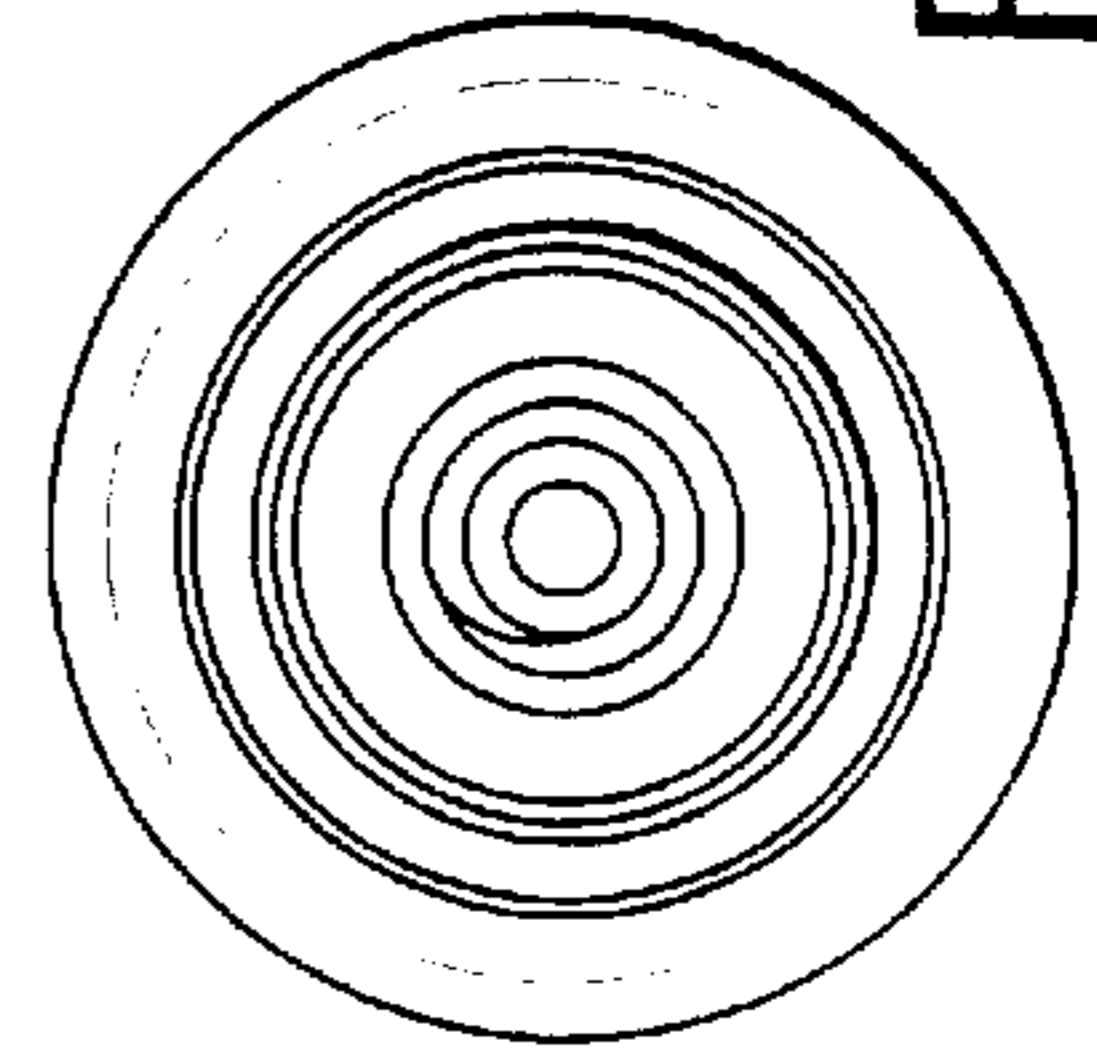

FIG. 51

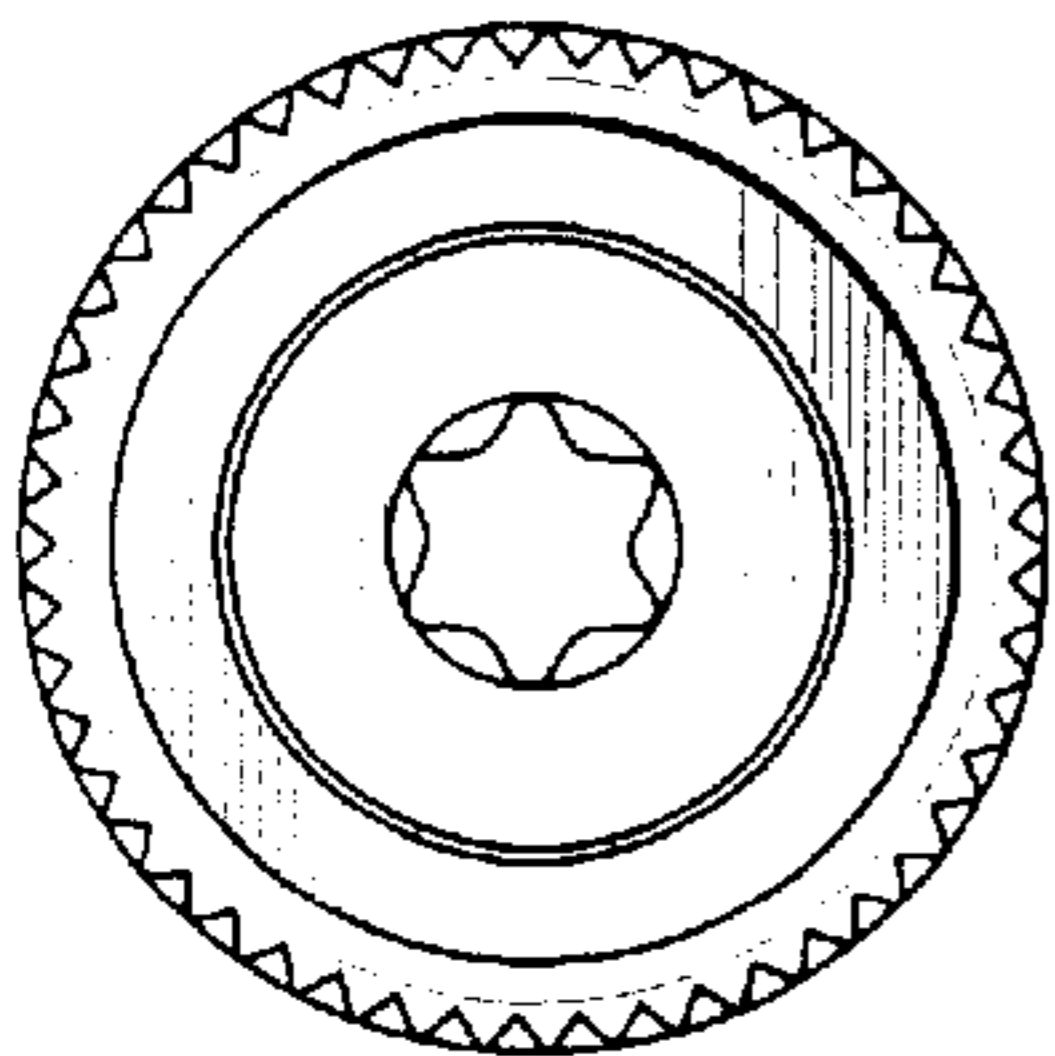

FIG. 60

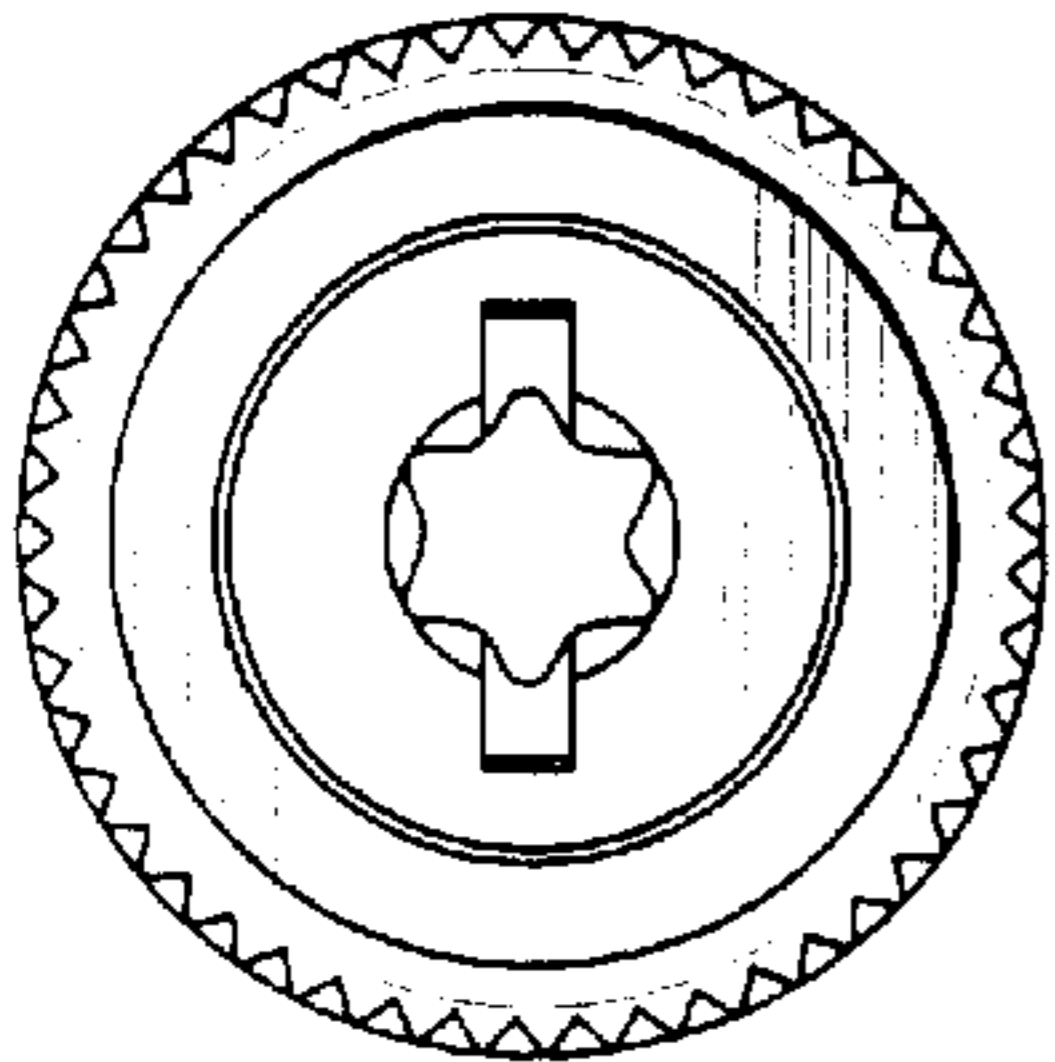

FIG. 61

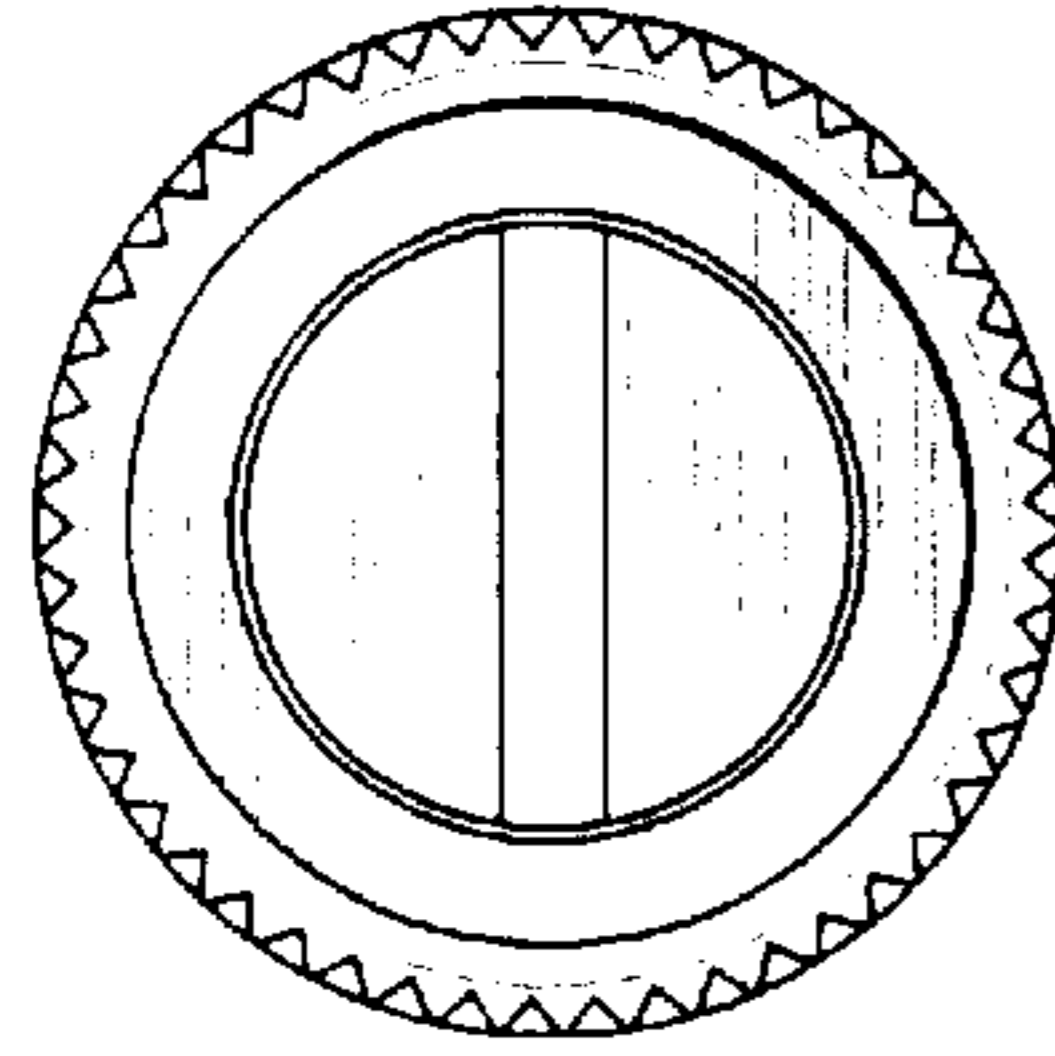

FIG. 62

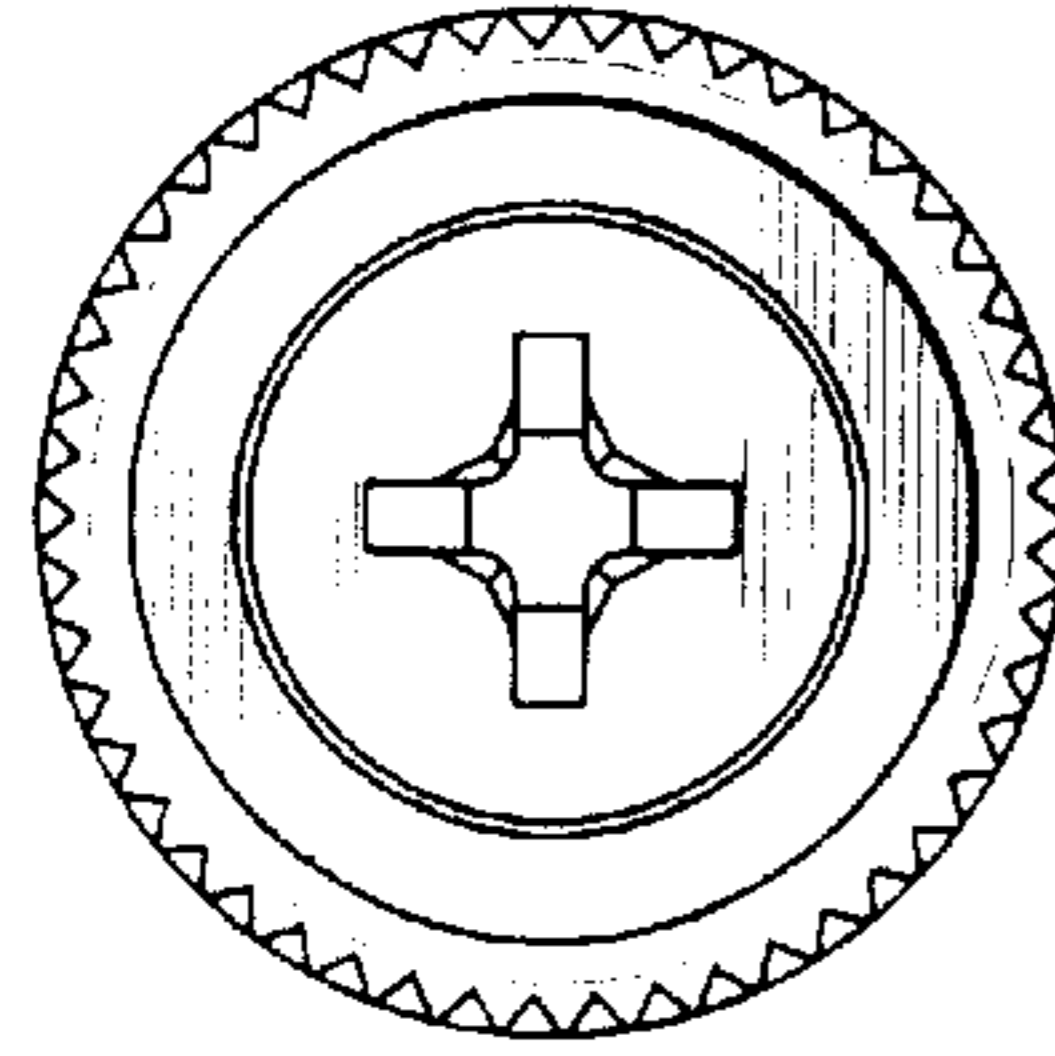

FIG. 63

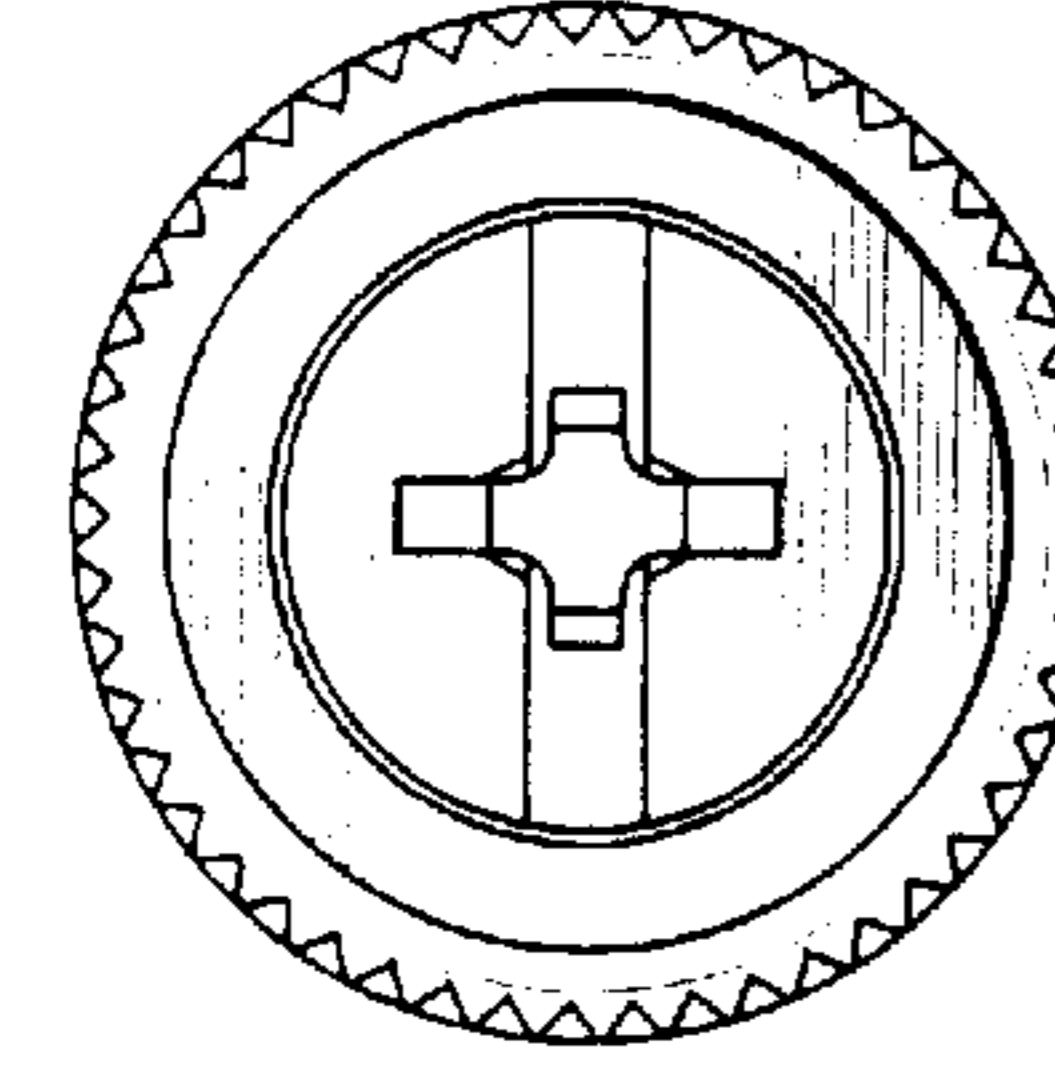

FIG. 64

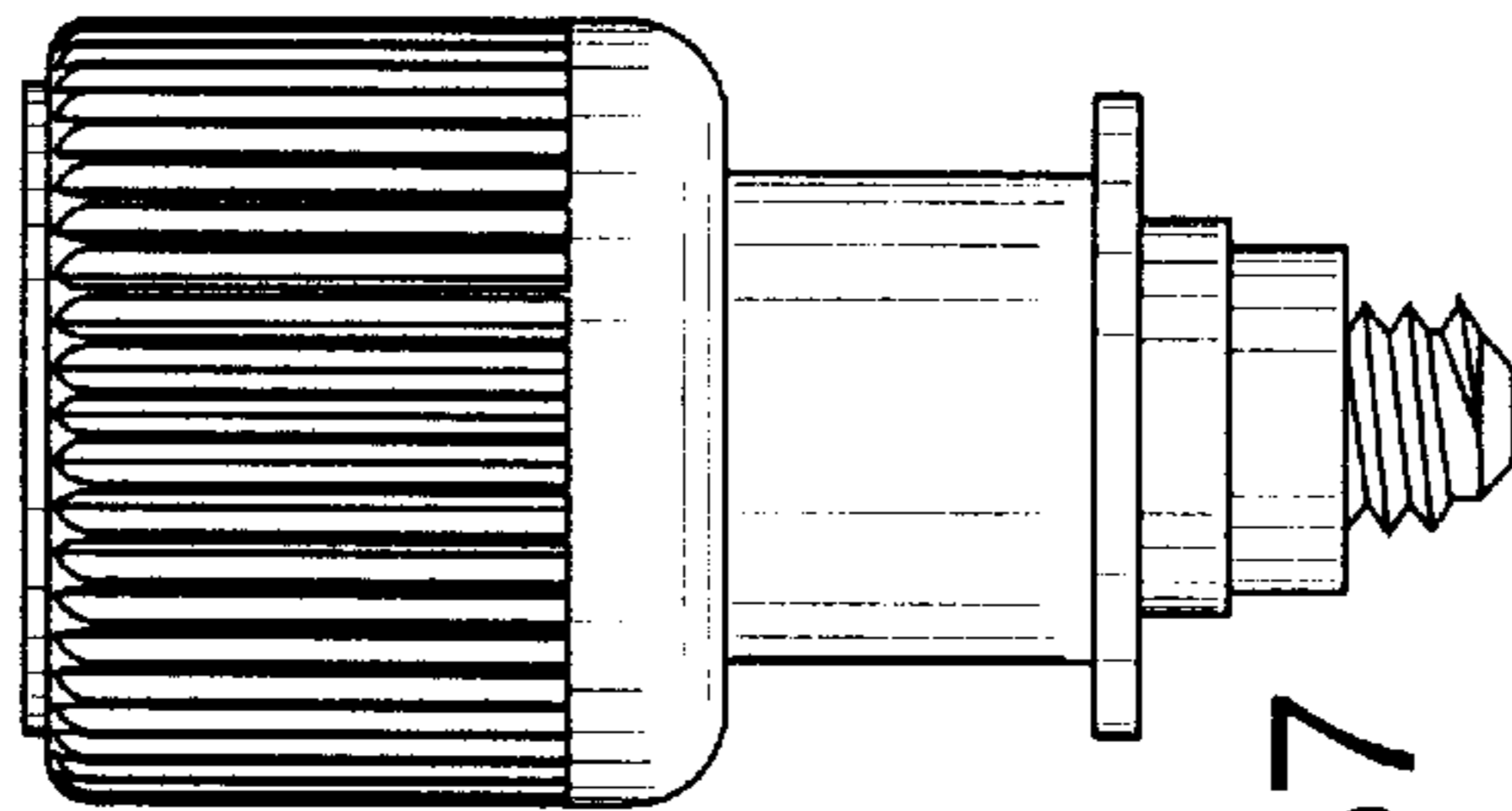

FIG. 57

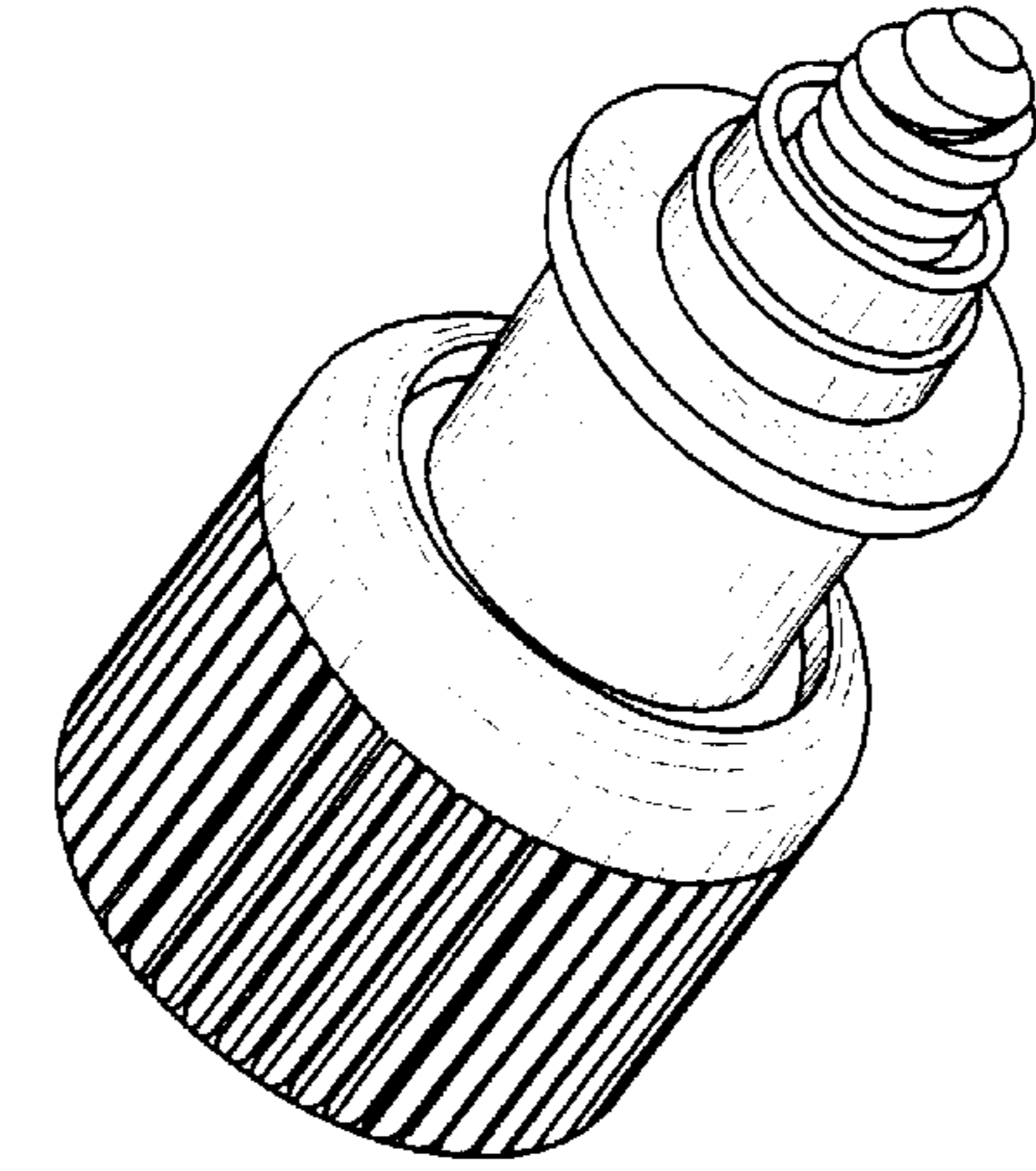

FIG. 58

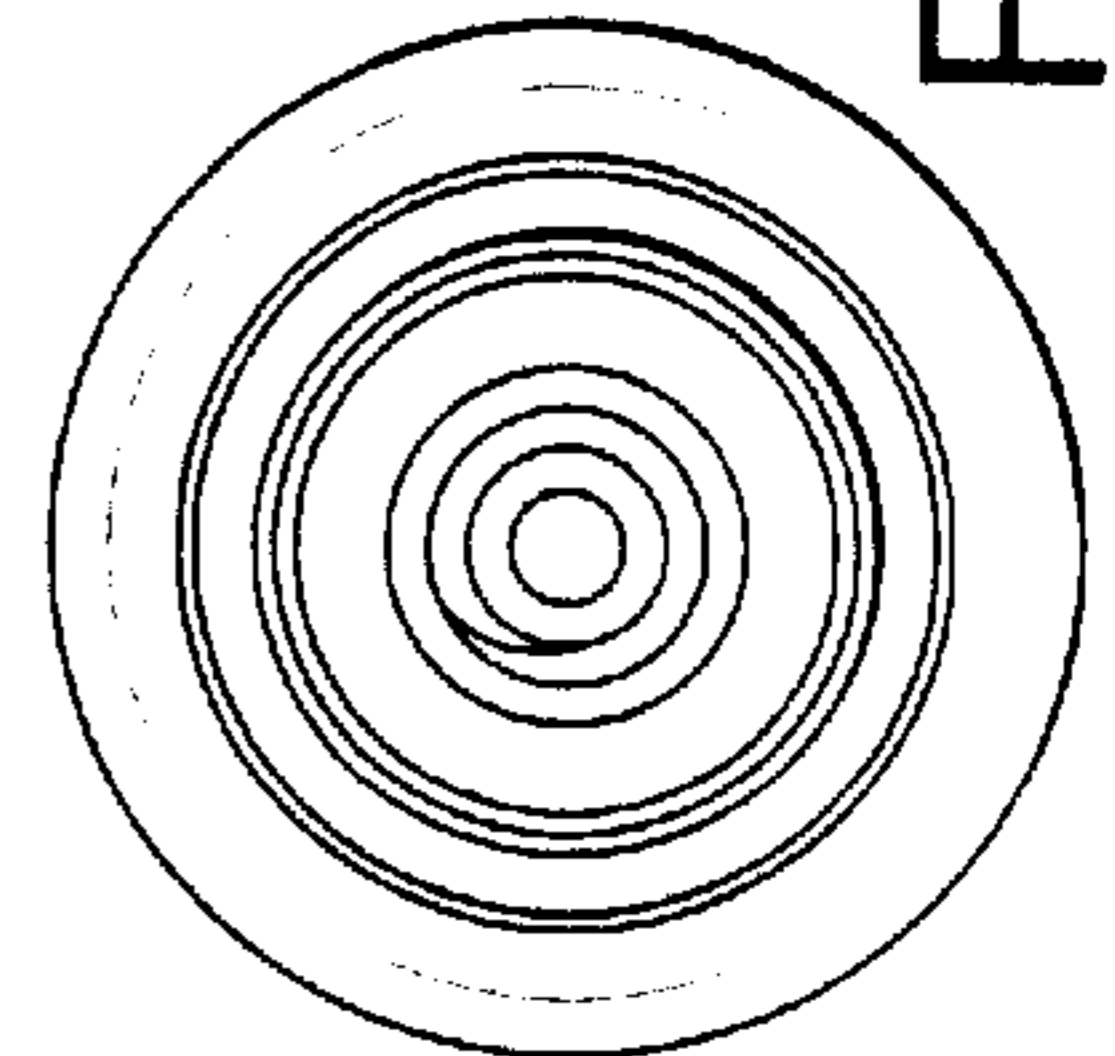

FIG. 59

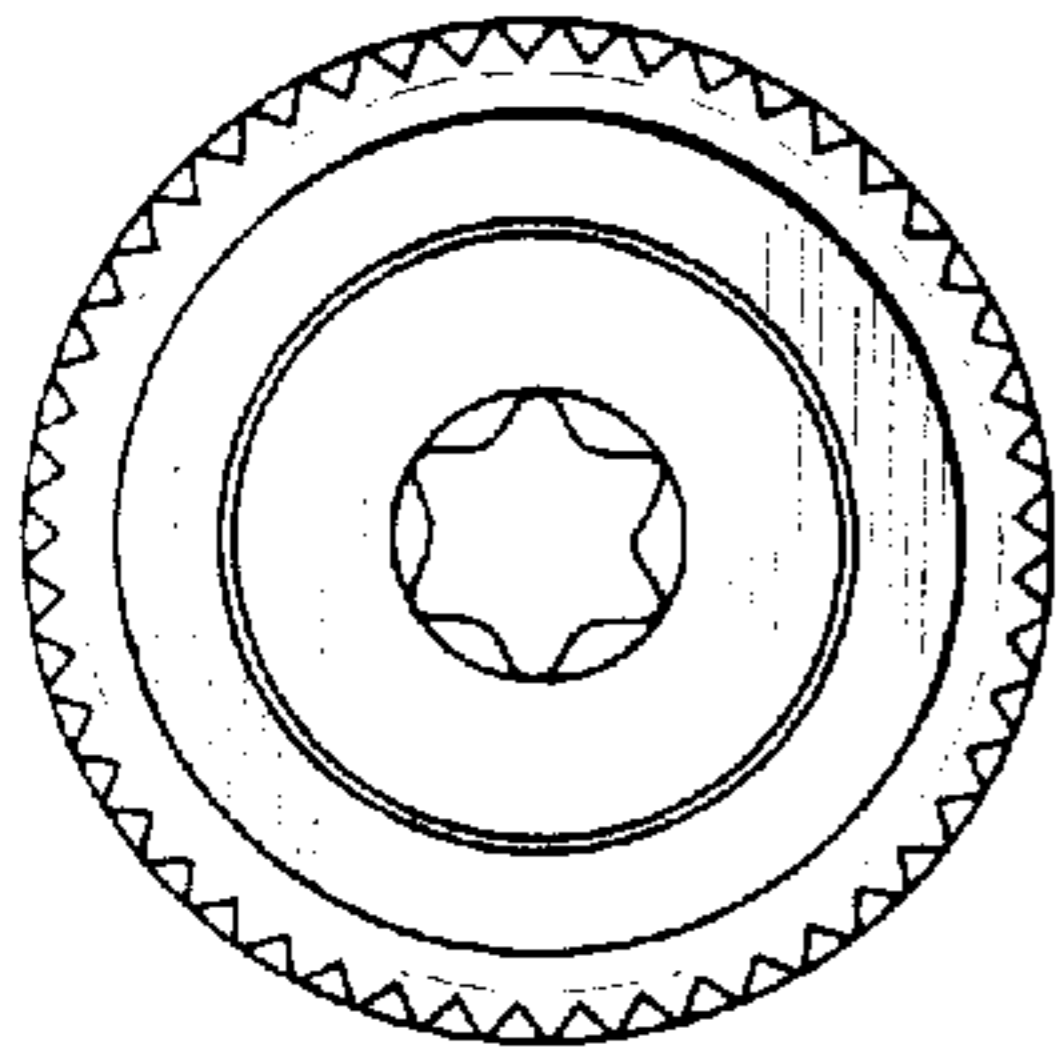

FIG. 68

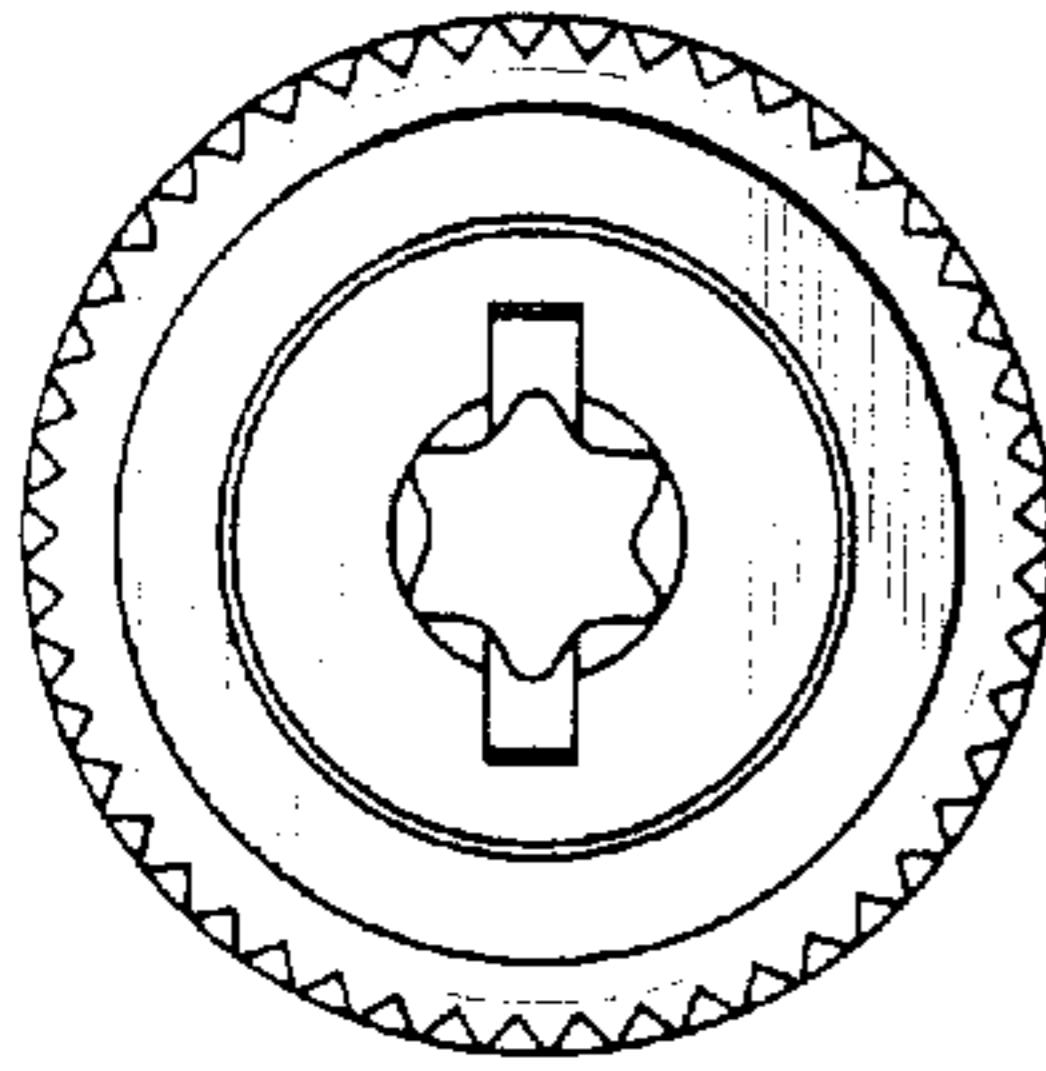

FIG. 69

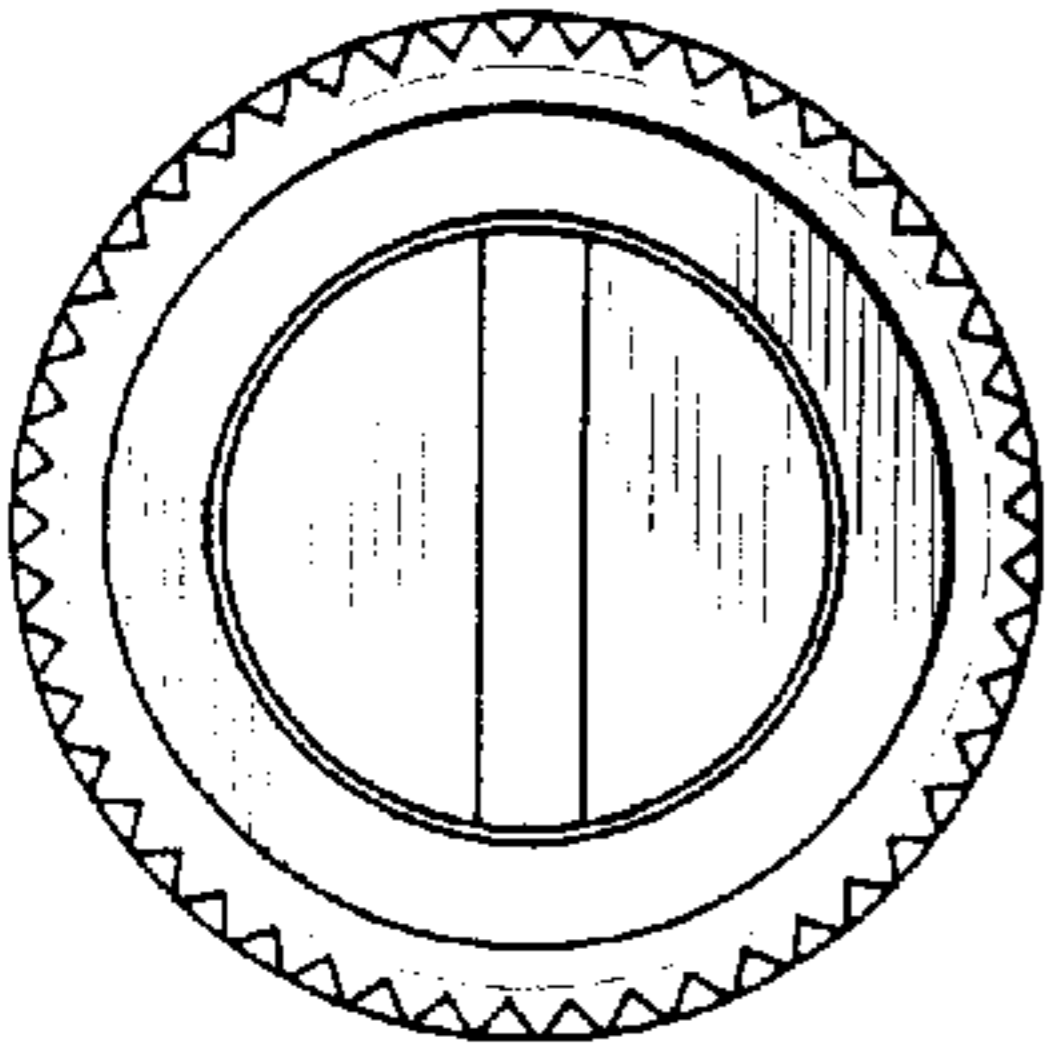

FIG. 70

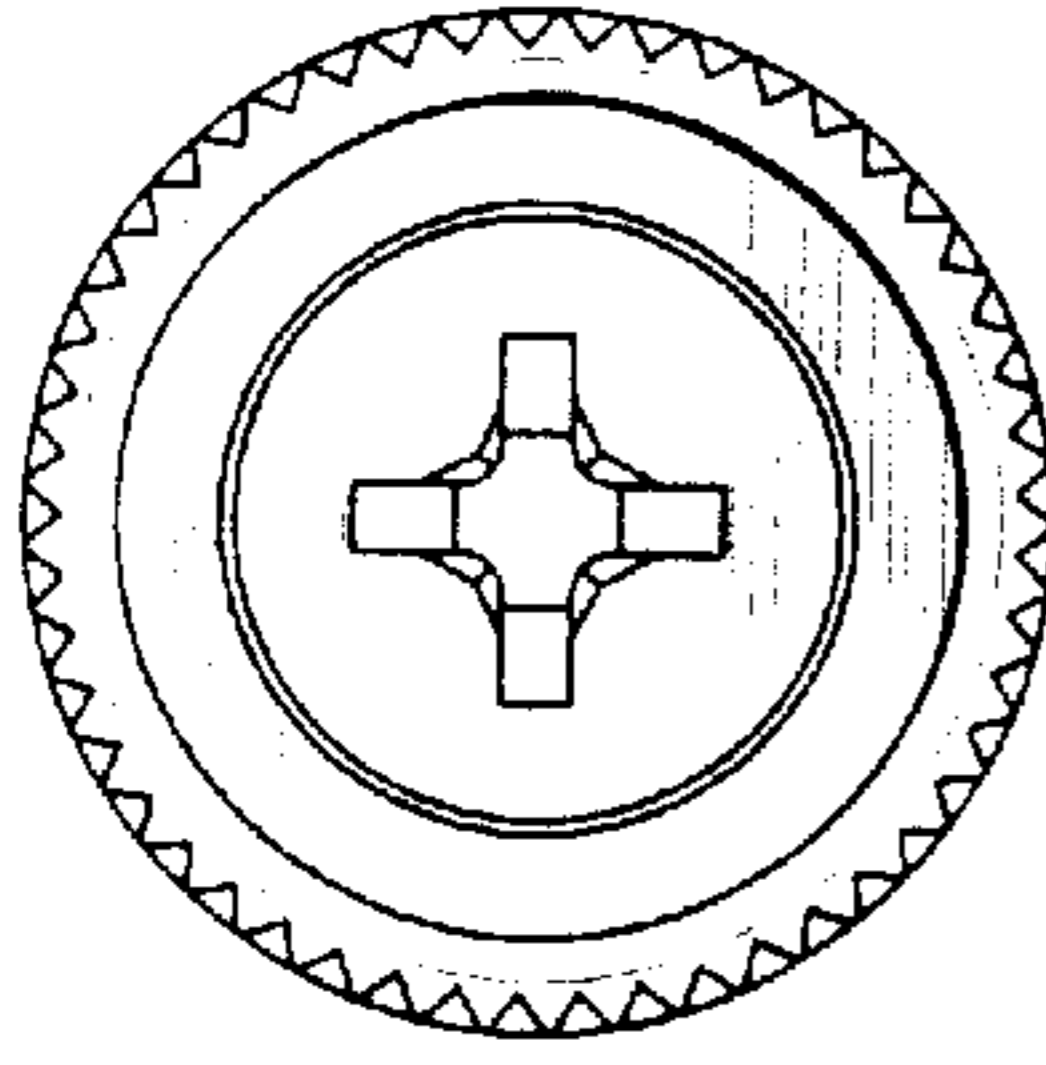

FIG. 71

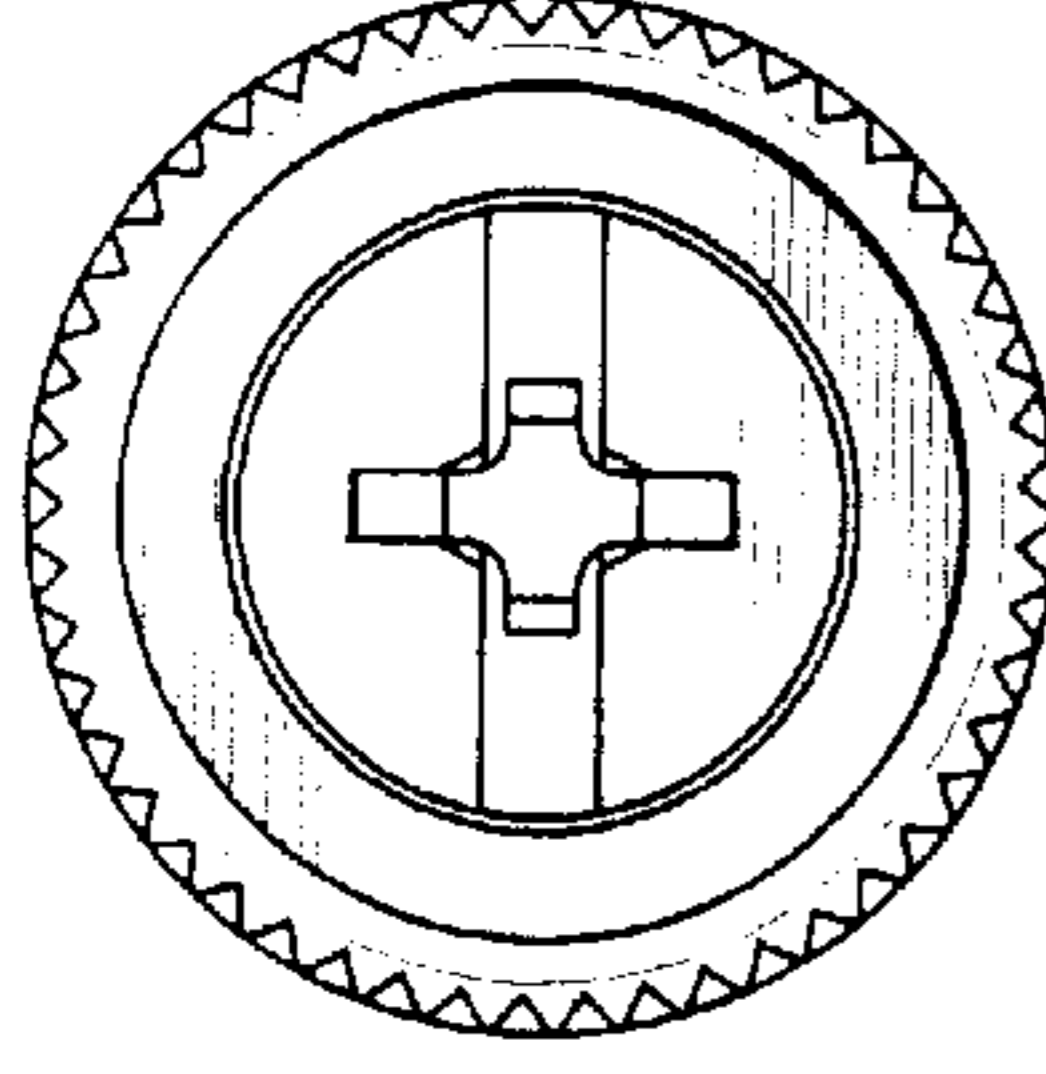

FIG. 72

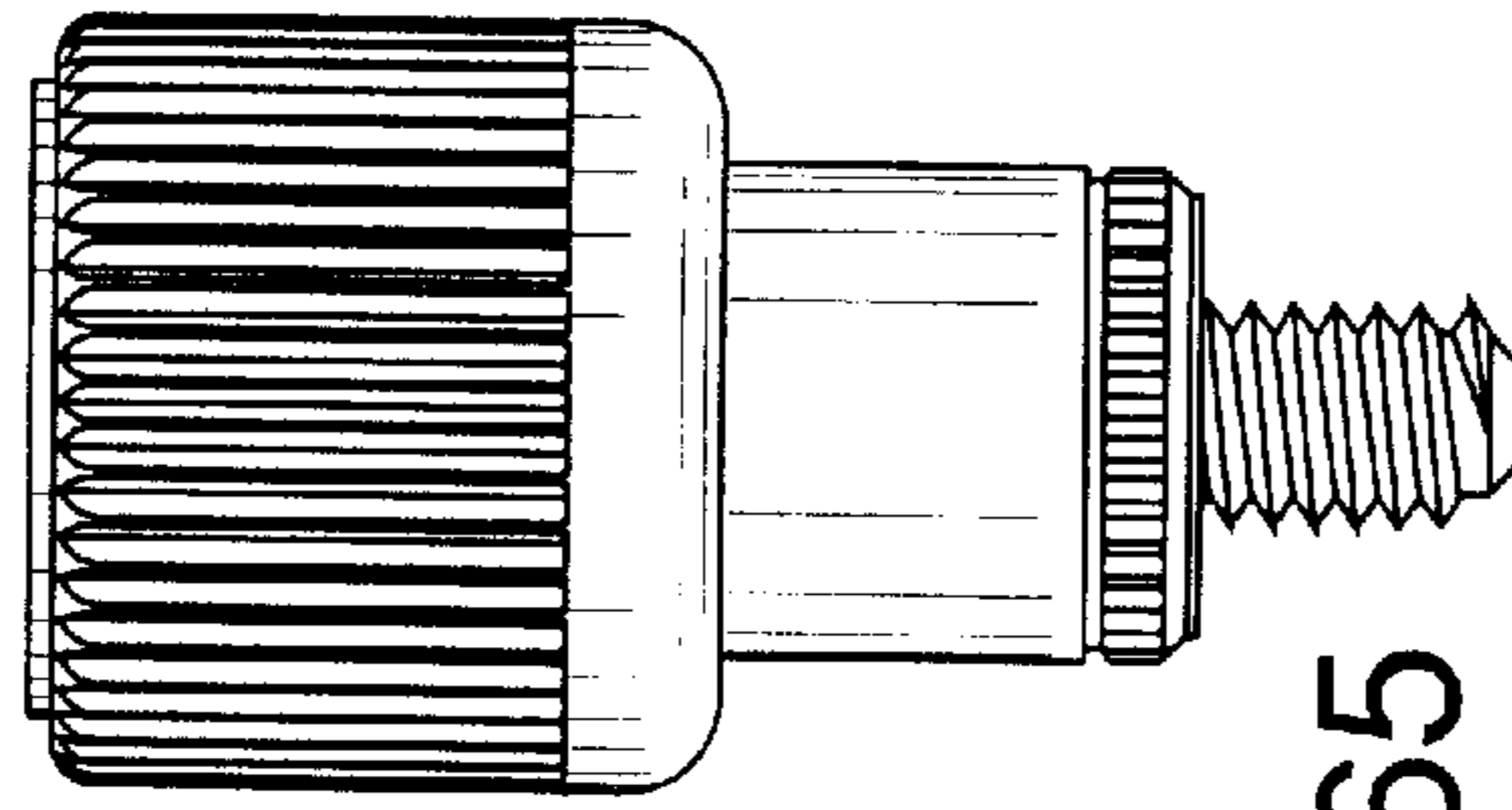

FIG. 65

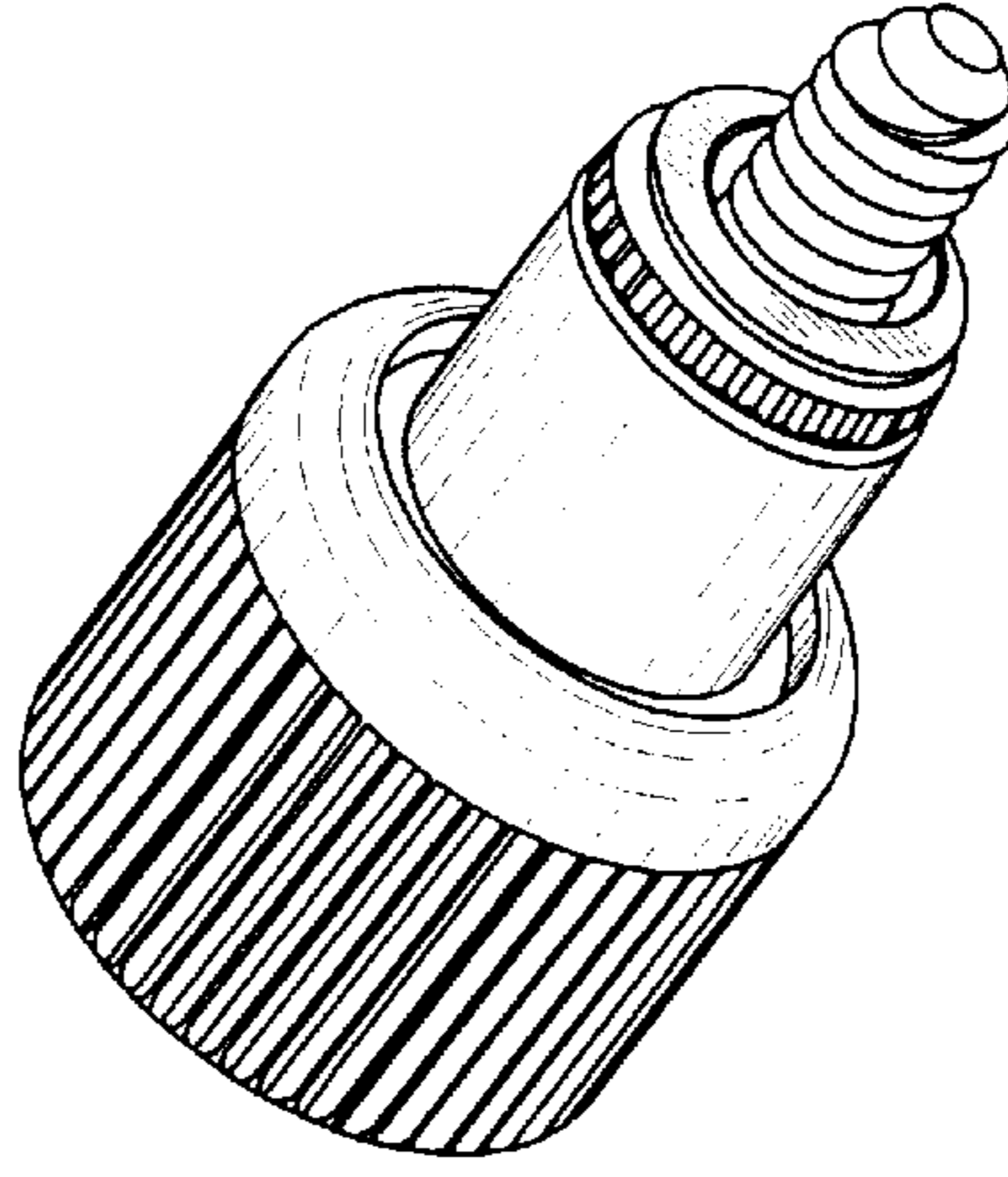

FIG. 66

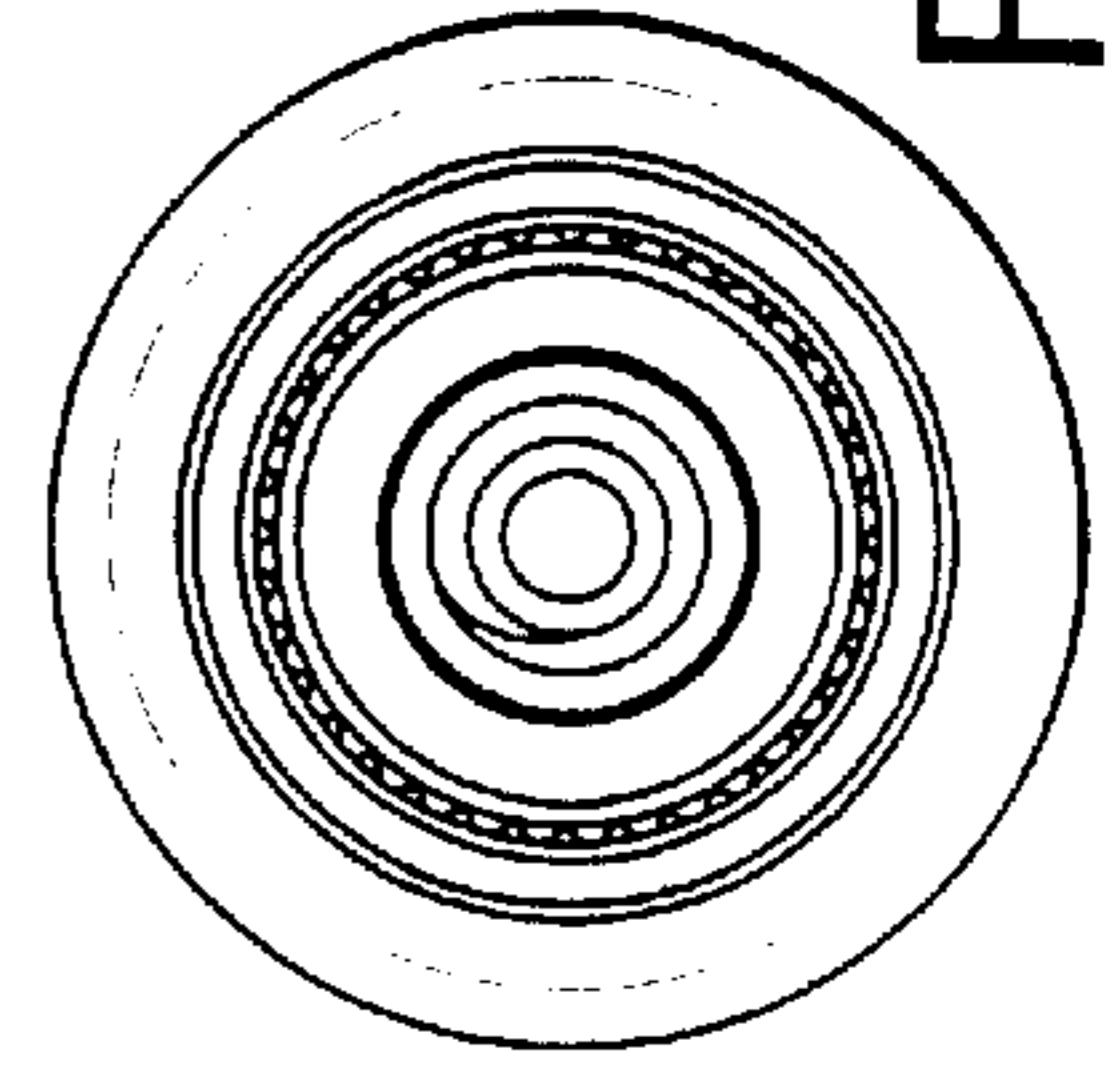

FIG. 67

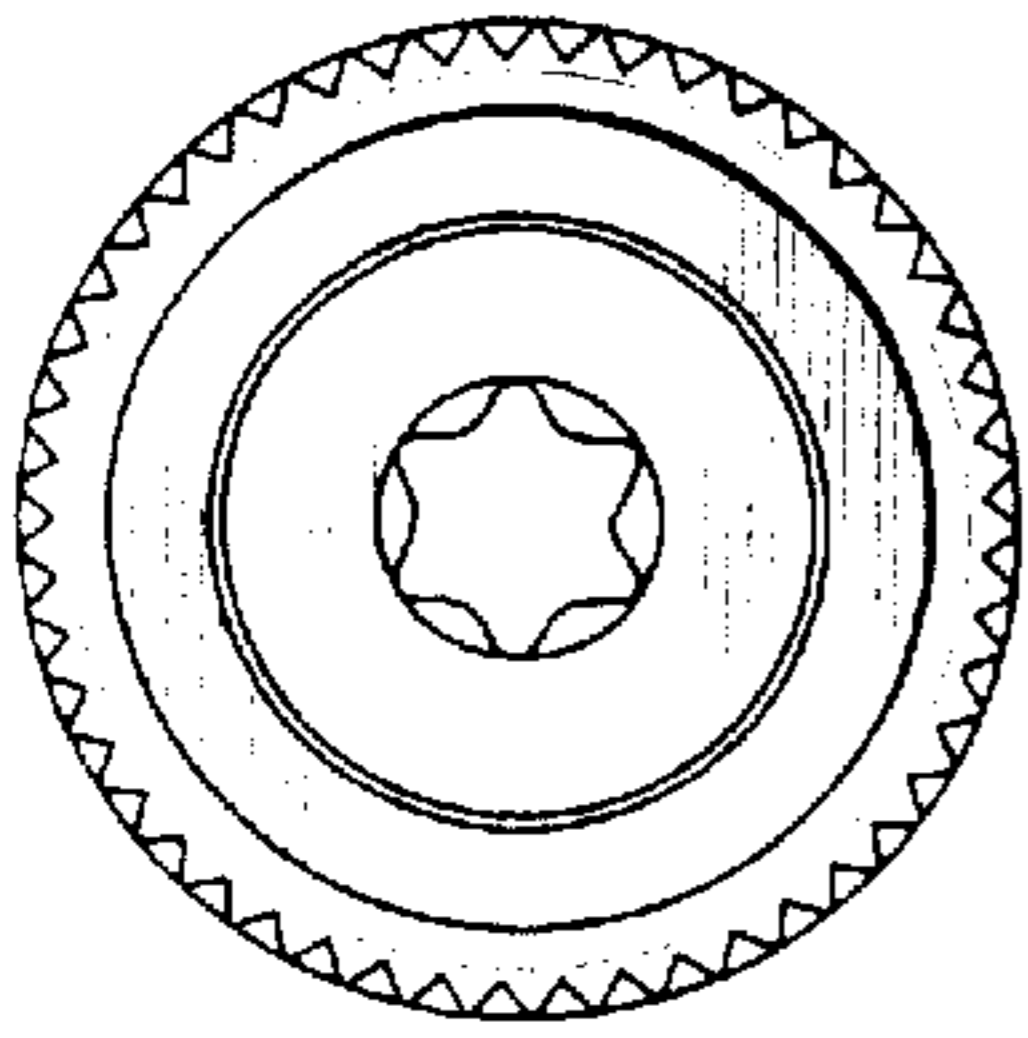

FIG. 76

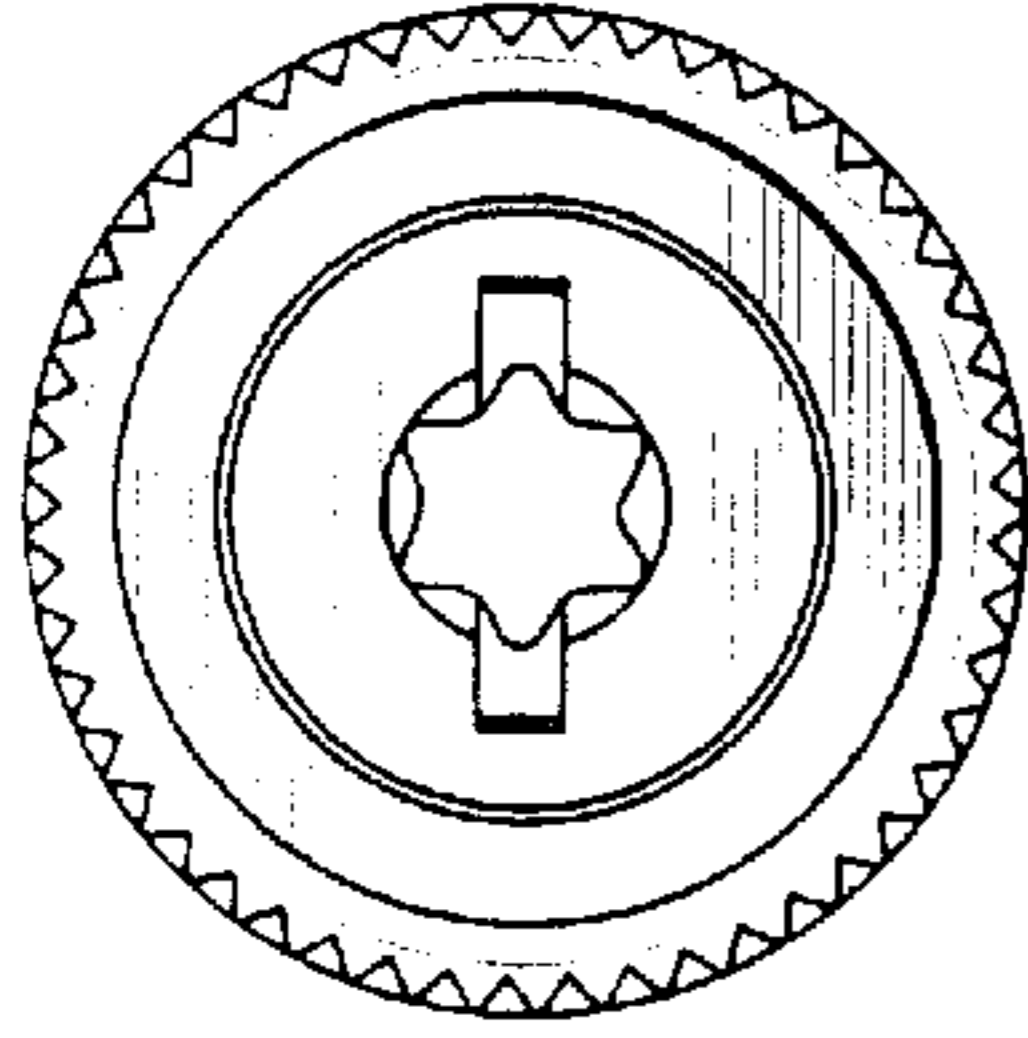

FIG. 77

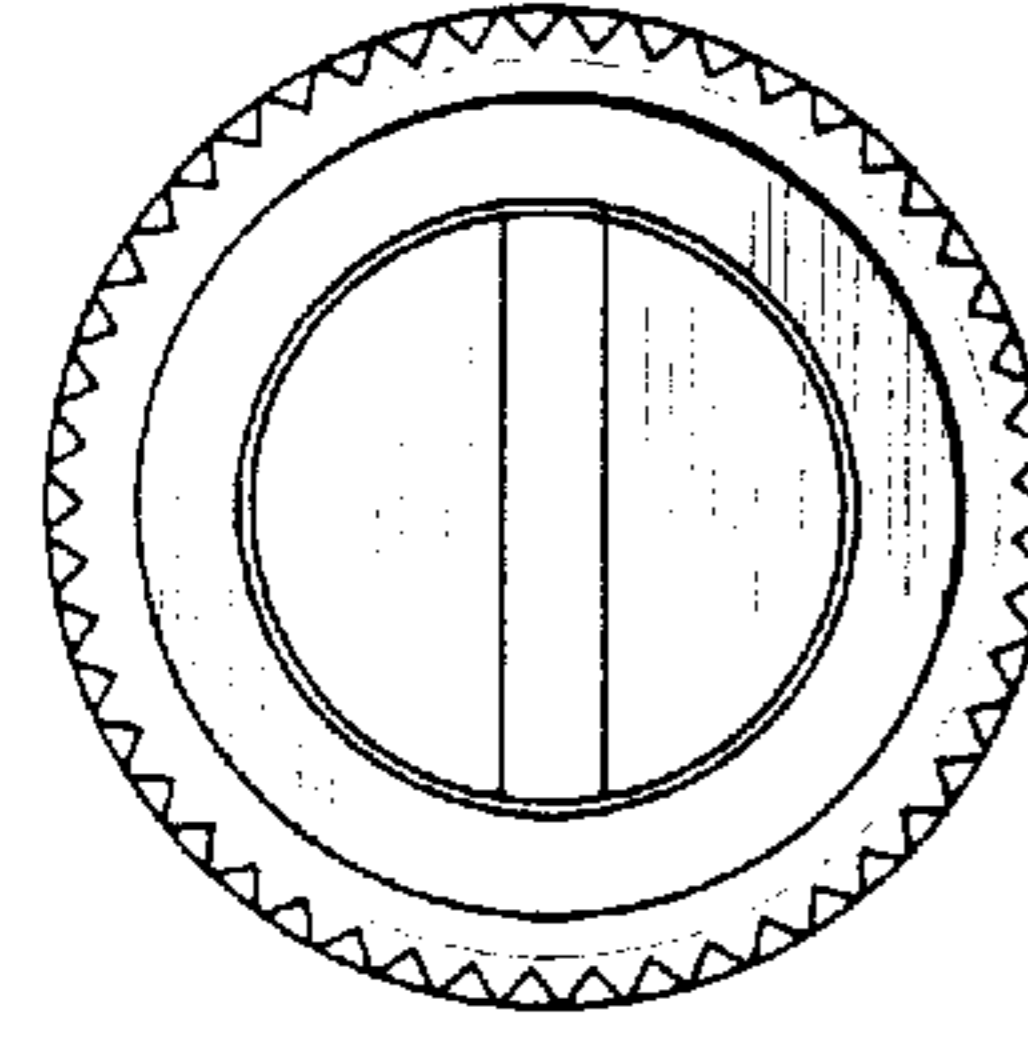

FIG. 78

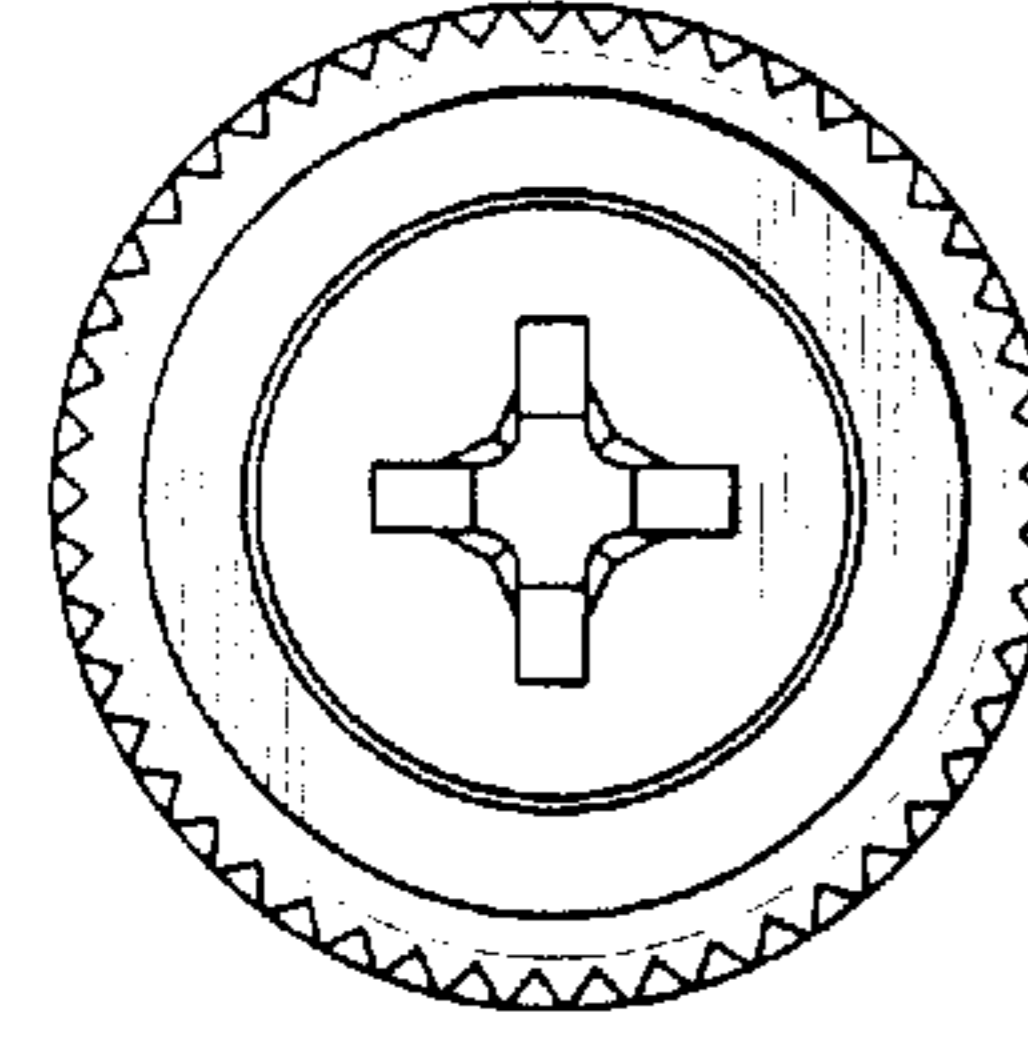

FIG. 79

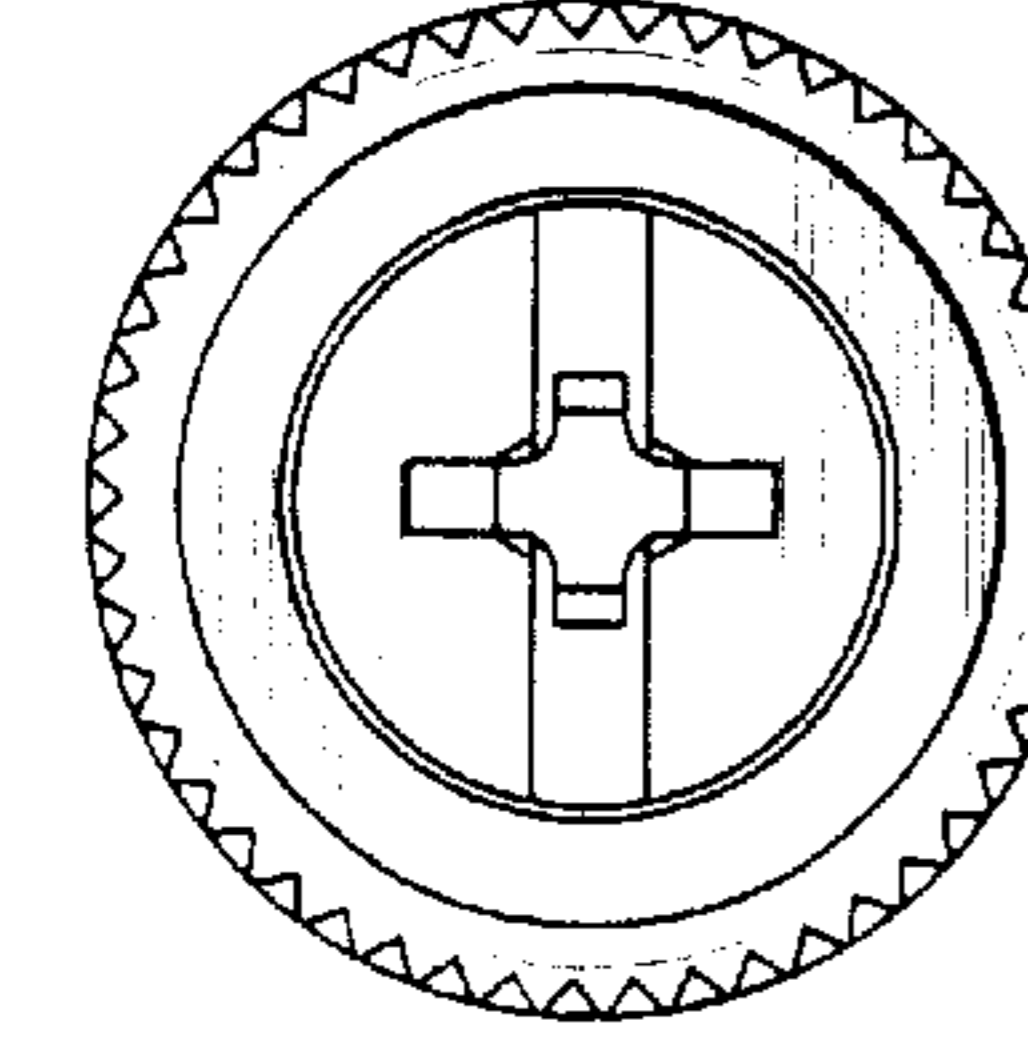

FIG. 80

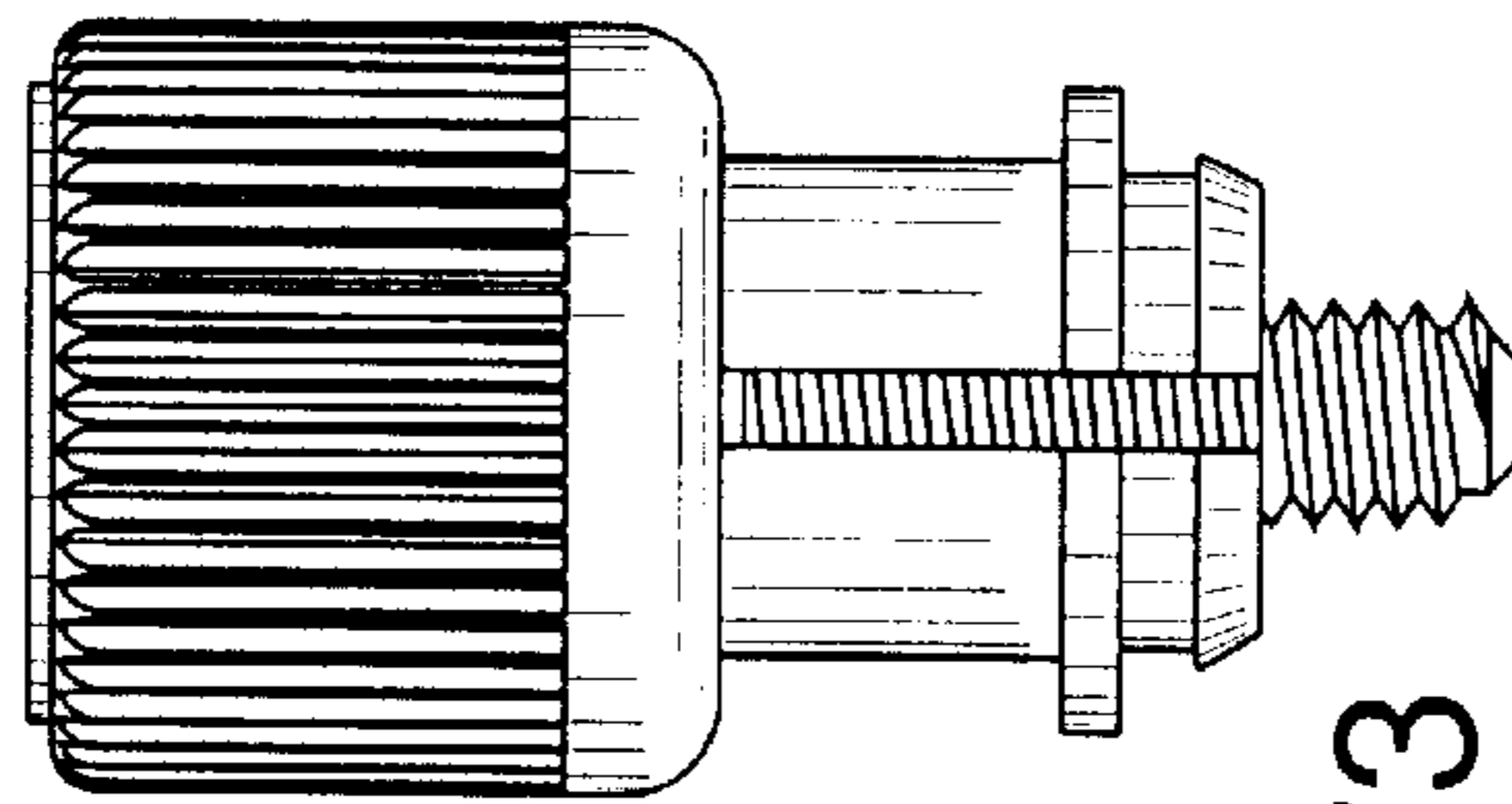

FIG. 73

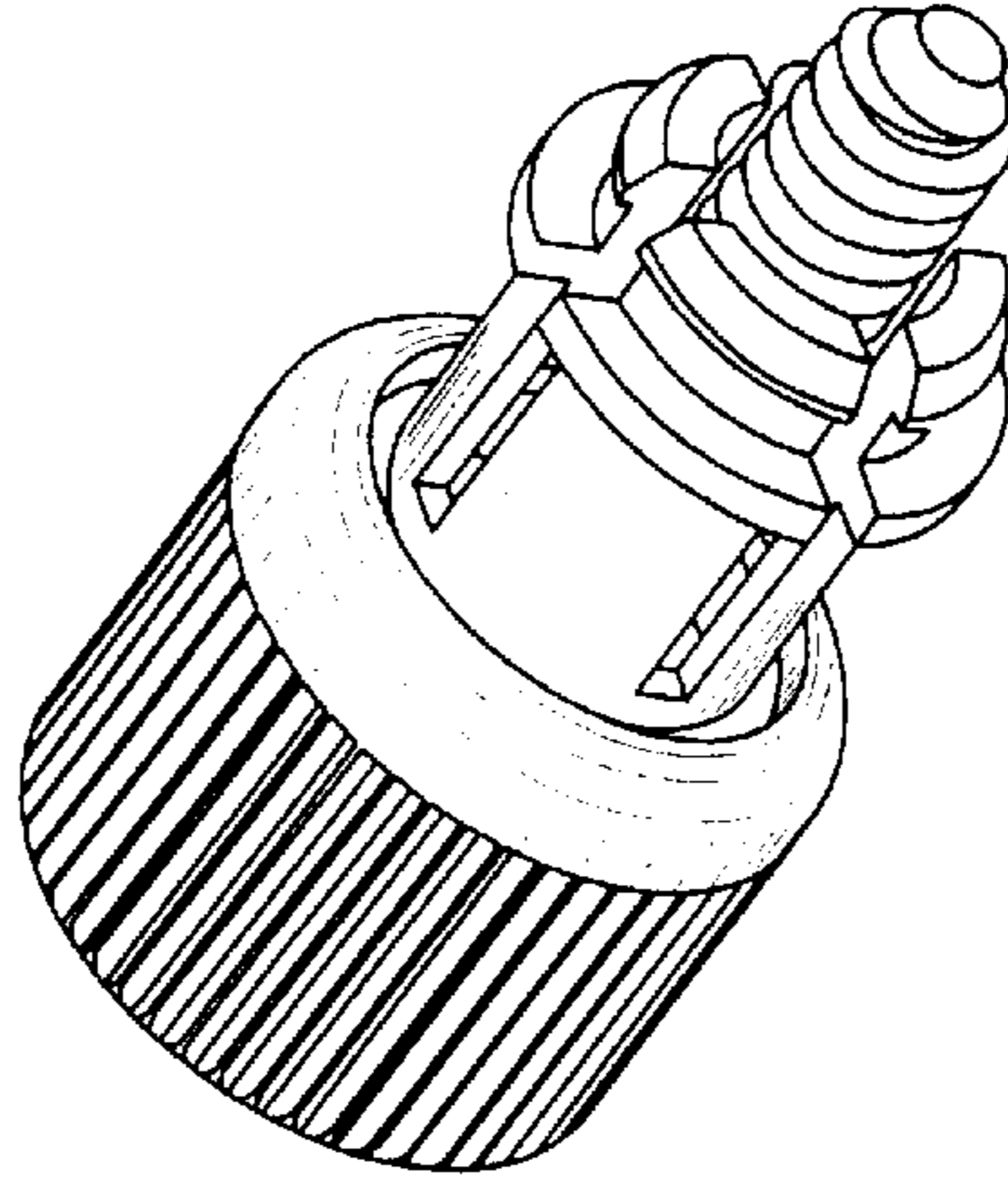

FIG. 74

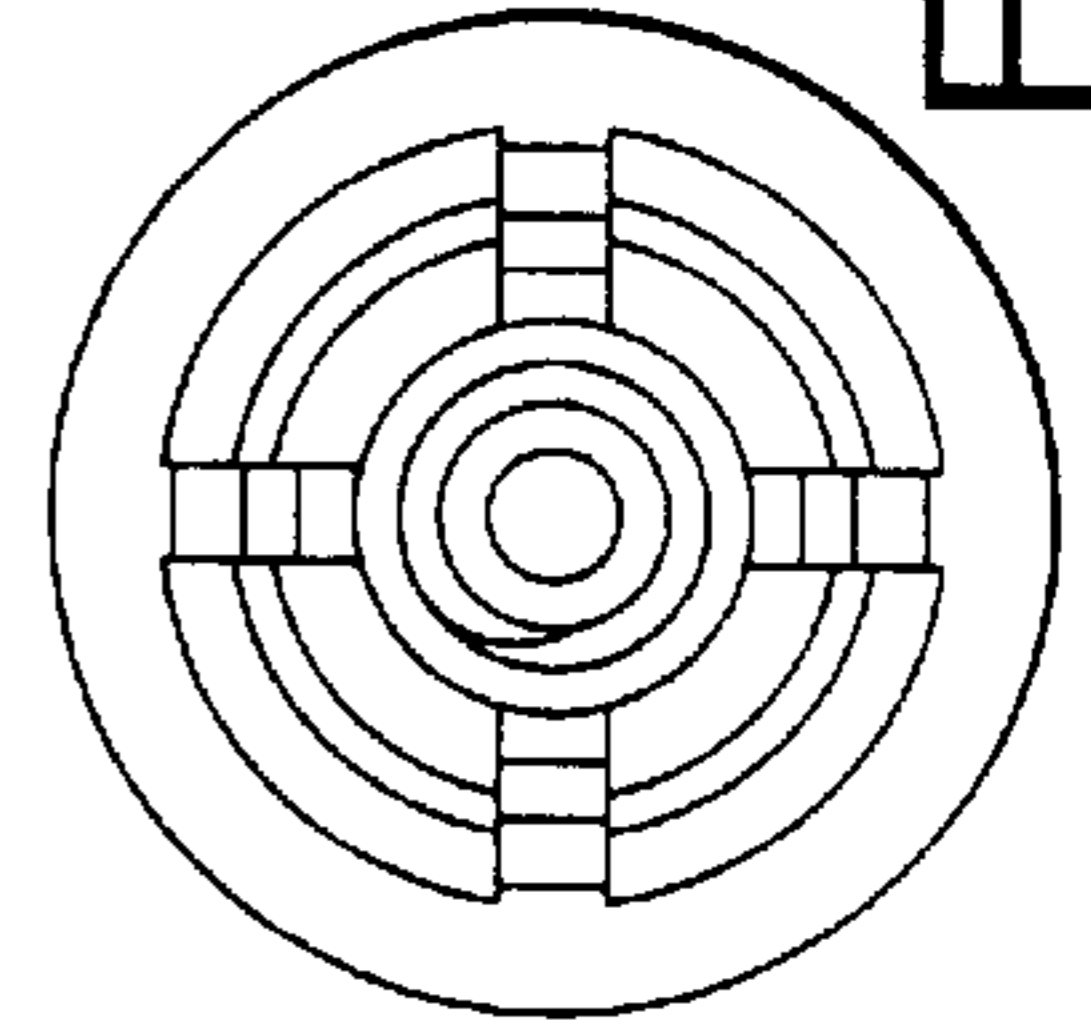

FIG. 75

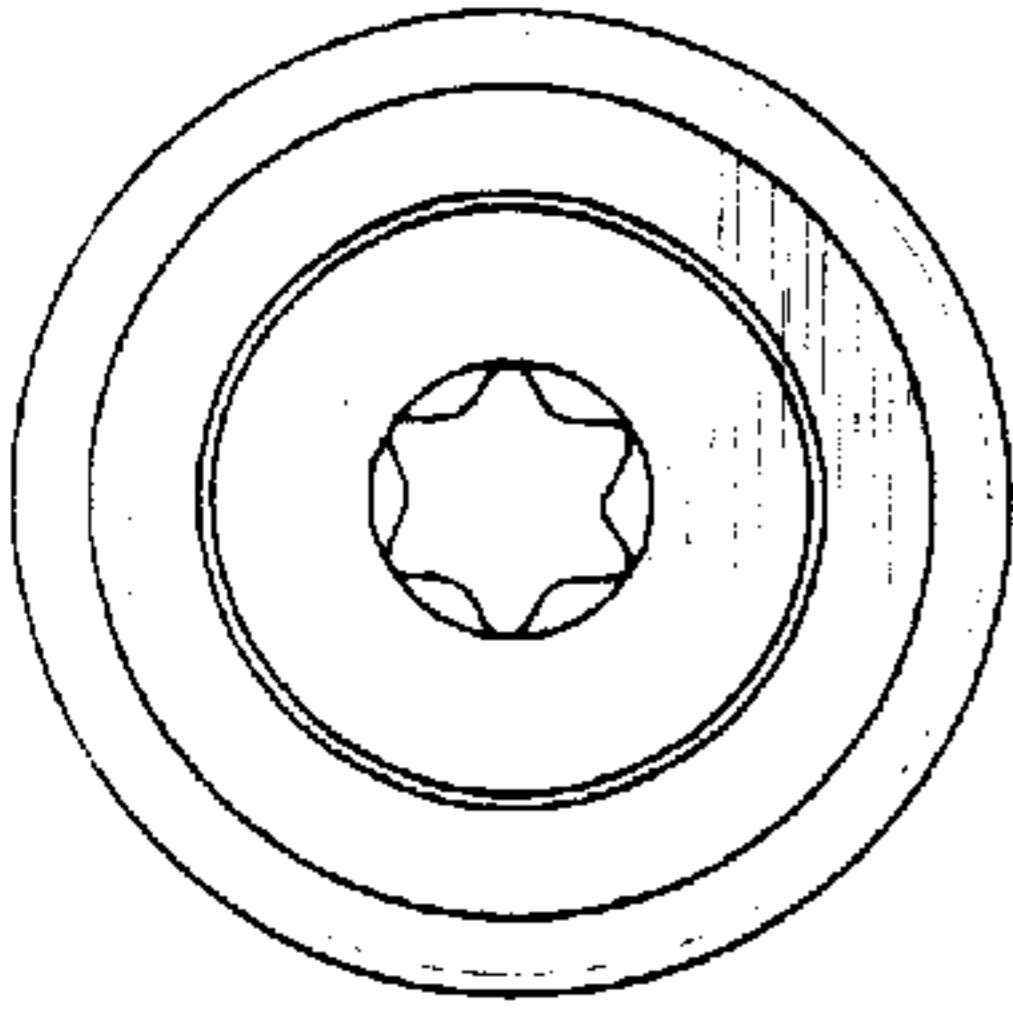

FIG. 84

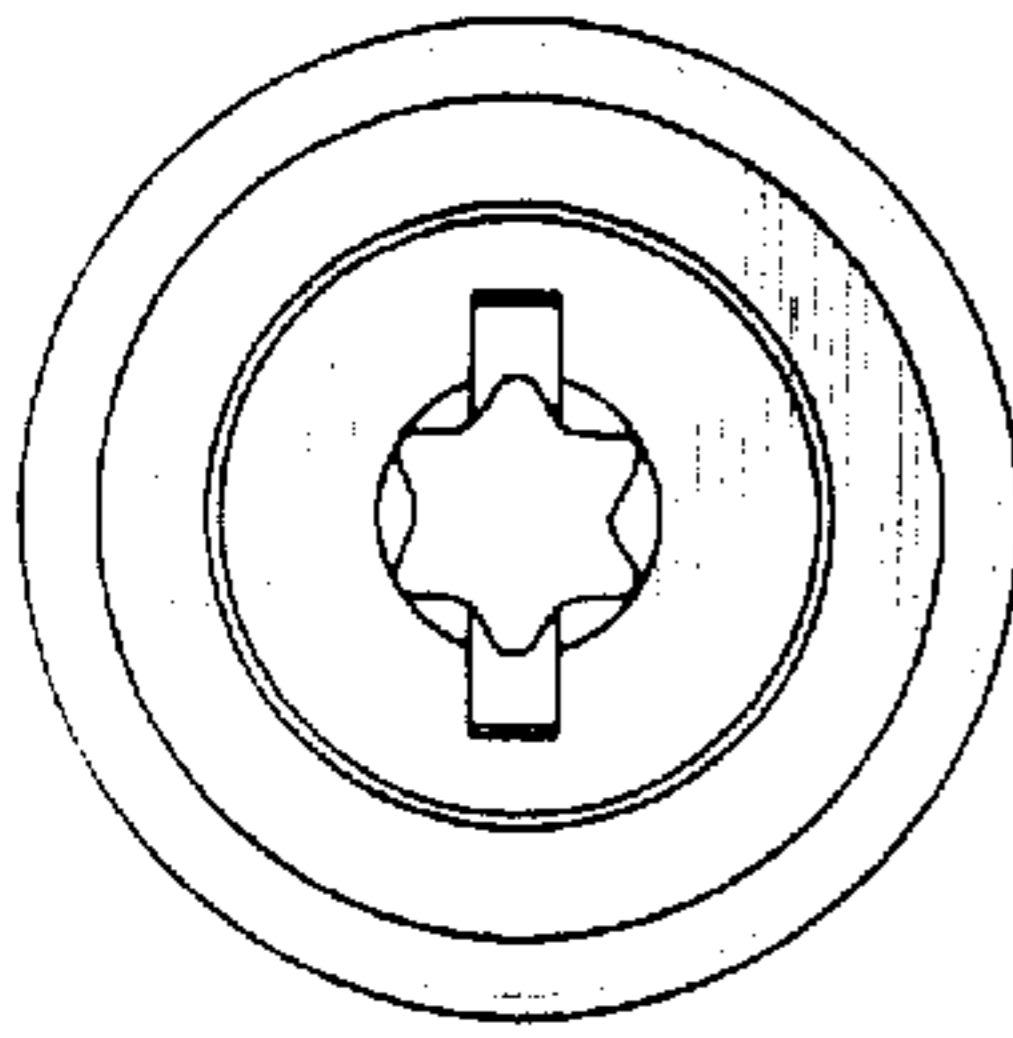

FIG. 85

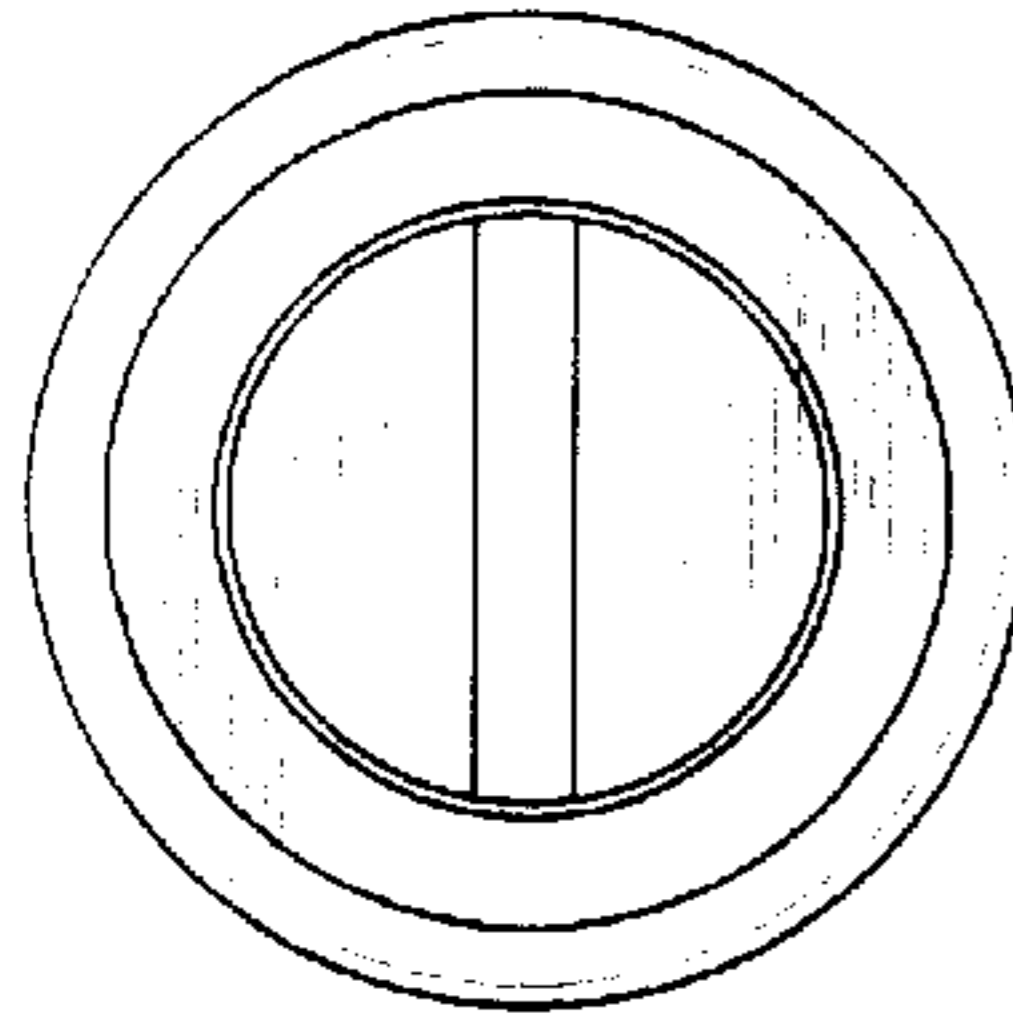

FIG. 86

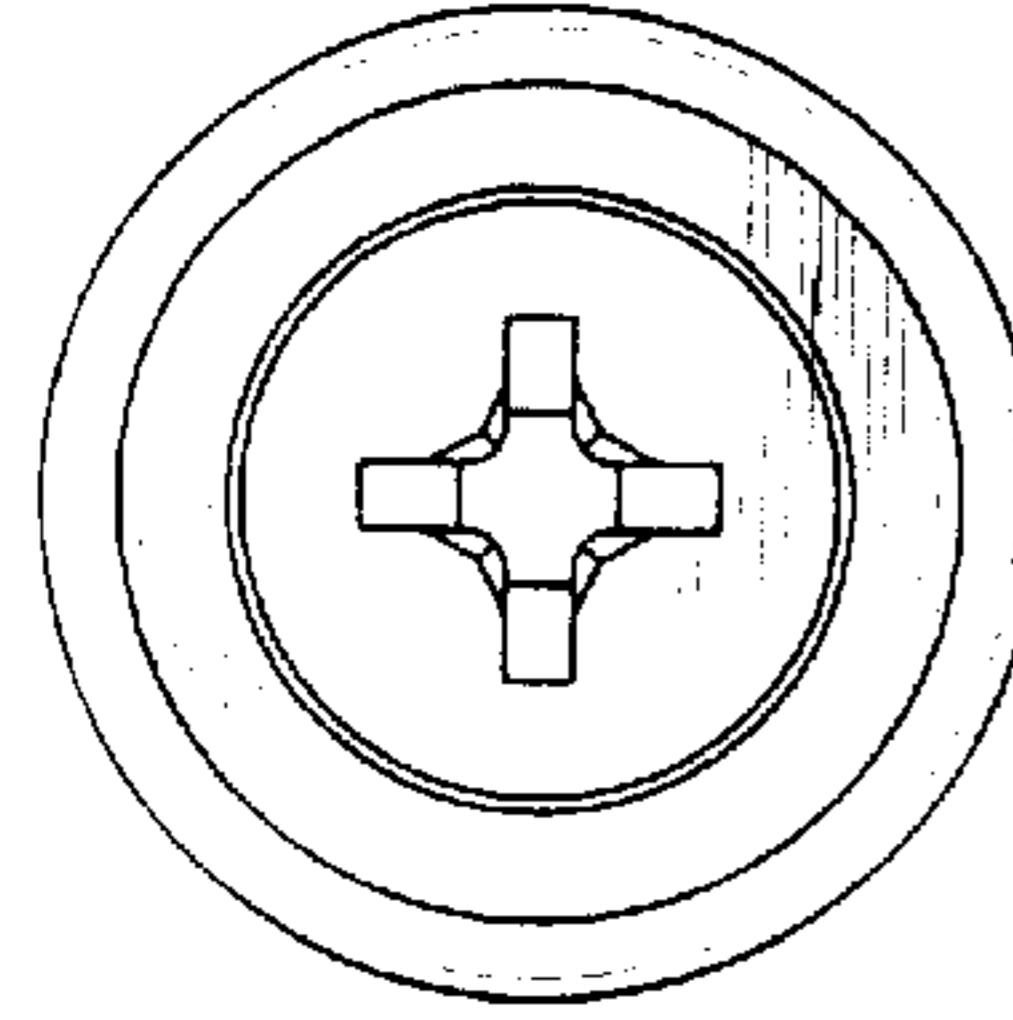

FIG. 87

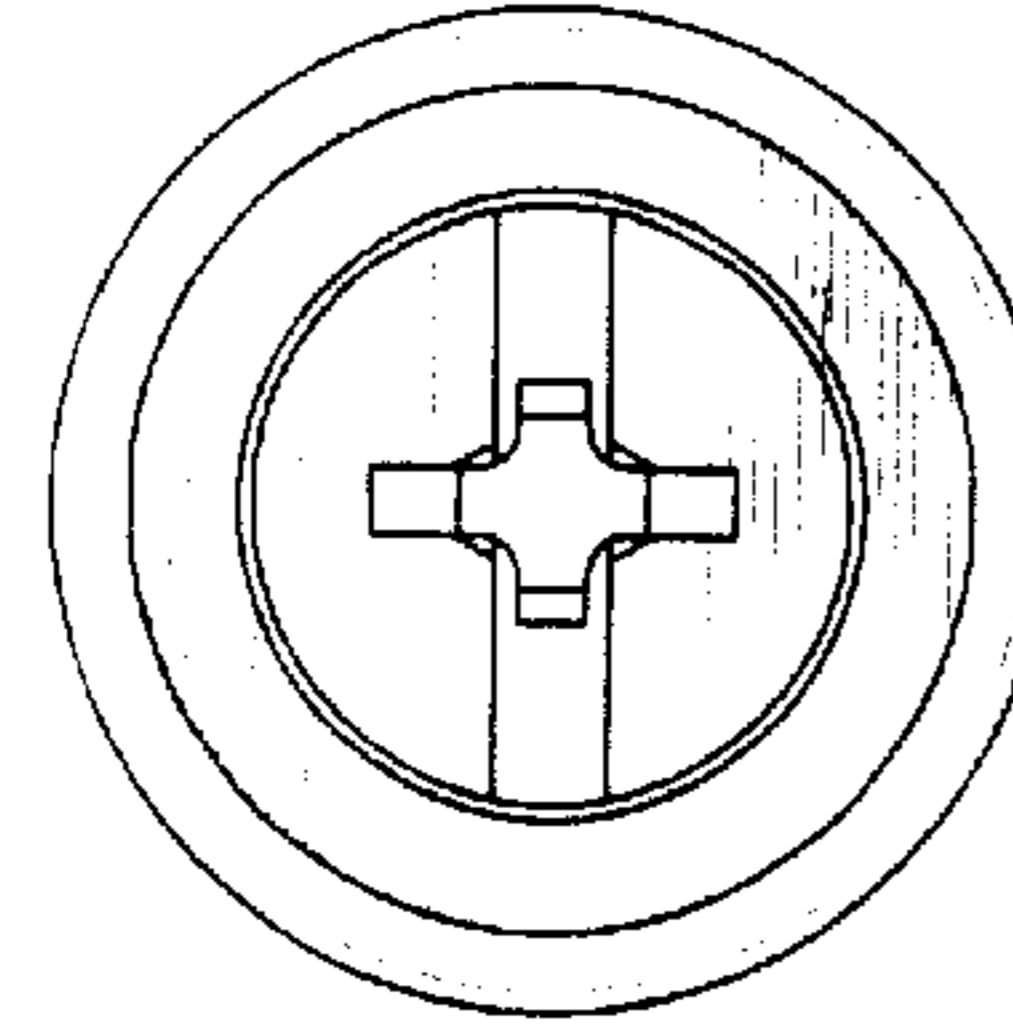

FIG. 88

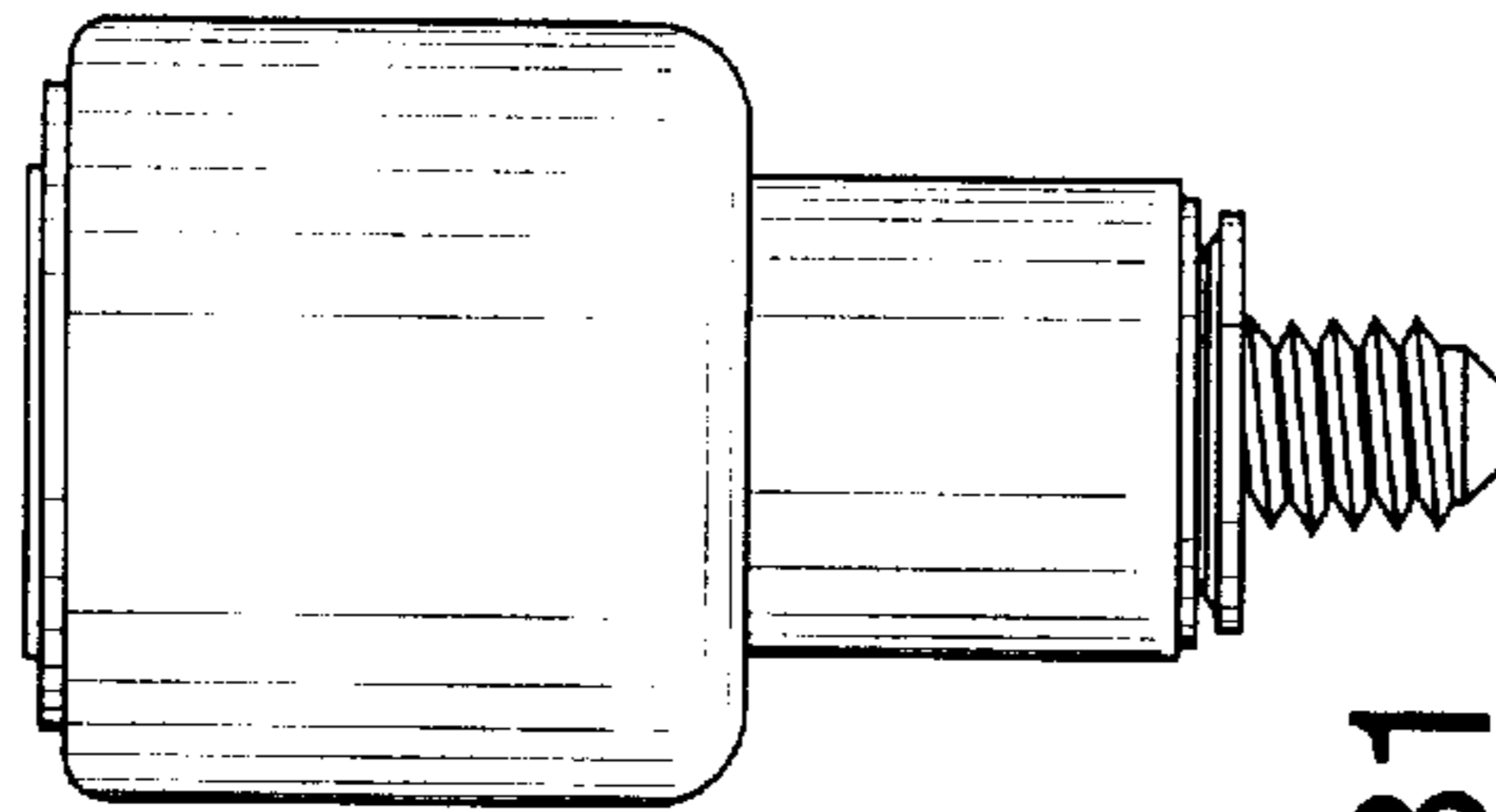

FIG. 81

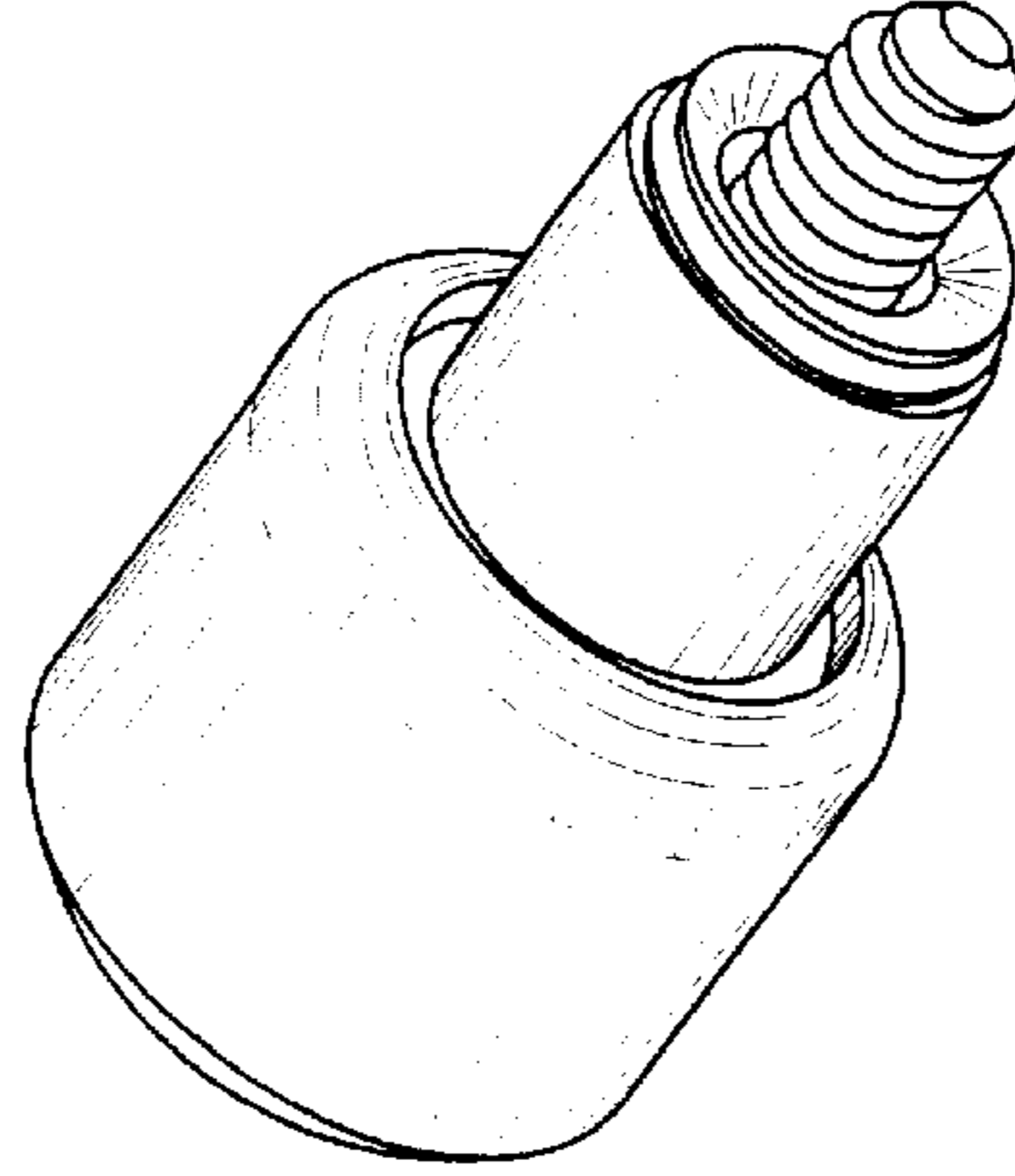

FIG. 82

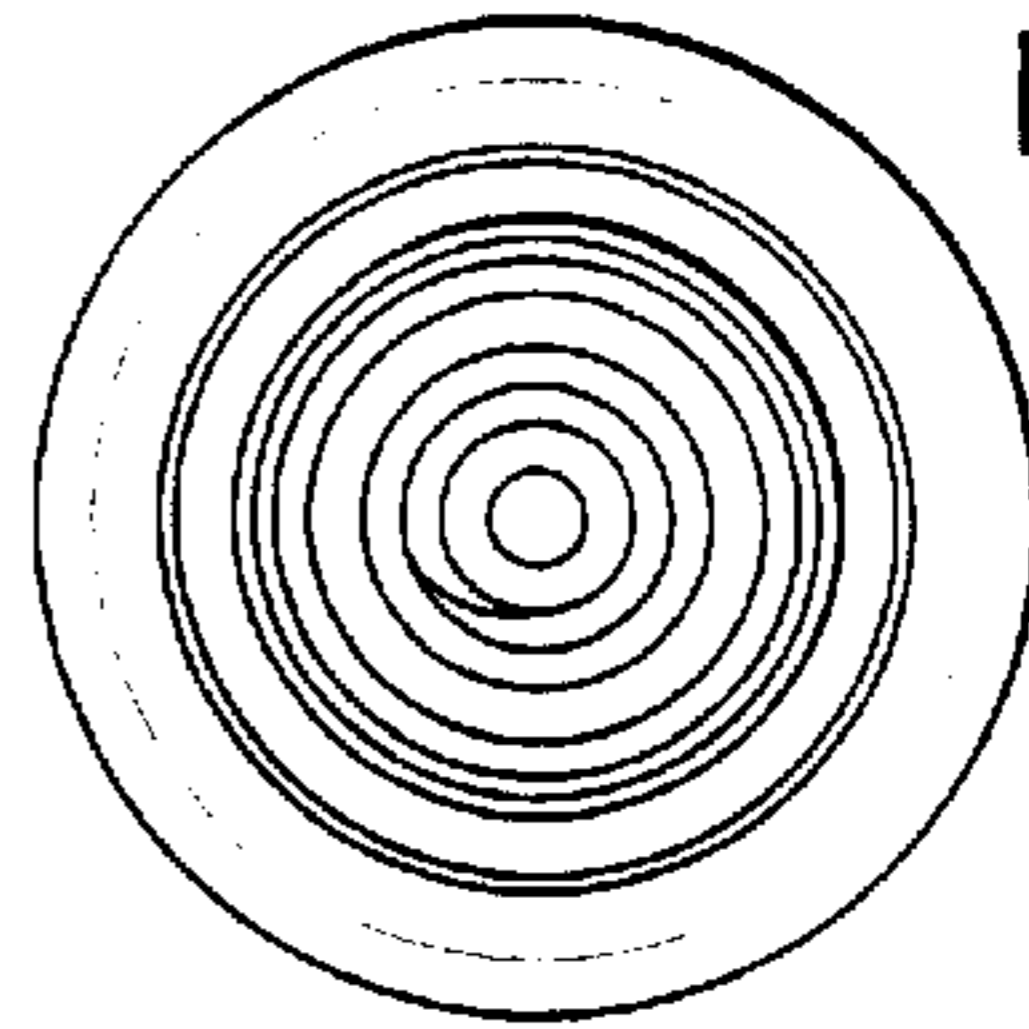

FIG. 83