



US00D472545S

(12) **United States Design Patent**  
**Iijima et al.**

(10) **Patent No.:** **US D472,545 S**

(45) **Date of Patent:** **\*\* Apr. 1, 2003**

(54) **SPEAKER**

TW 119027 9/1989

(75) Inventors: **Takekazu Iijima**, Maguro-ku (JP);  
**Yumi Takigami**, Meguro-ku (JP); **Koji Nakane**, Meguro-ku (JP)

**OTHER PUBLICATIONS**

Lonesome Car-boy, vol. 5, 1985, "TS-205", p. 49.  
Carrozzeria, vol. 3, 1996, "TS-4677" and "TS-4688", p. 38.  
Carrozzeria, vol. 4, 1996, "TS-1299A", p. 36 and  
"TS-4688", p. 37.  
Carrozzeria, vol. 1, 1997, "TS-4688", p. 41.

(73) Assignee: **Pioneer Kabushiki Kaisha**, Tokyo (JP)

(\*\*) Term: **14 Years**

\* cited by examiner

(21) Appl. No.: **29/155,874**

*Primary Examiner*—Nanda Bondade

(22) Filed: **Feb. 21, 2002**

(74) *Attorney, Agent, or Firm*—Oliff & Berridge, PLC

(30) **Foreign Application Priority Data**

(57) **CLAIM**

Oct. 24, 2001 (JP) ..... 2001-031181

The ornamental design for speaker, as shown and described.

(51) **LOC (7) Cl.** ..... **14-01**

**DESCRIPTION**

(52) **U.S. Cl.** ..... **D14/219; D14/221**

(58) **Field of Search** ..... D14/204, 207,  
D14/209-216, 356; 181/144-145, 147-148,  
150, 153, 157, 198-199; 381/189, 333,  
391, 433

FIG. 1 is a perspective view of a speaker;  
FIG. 2 is a front view thereof;  
FIG. 3 is a plan view thereof;  
FIG. 4 is an opposite plan view thereof;  
FIG. 5 is a right side view thereof; and,  
FIG. 6 is a left side view thereof.

(56) **References Cited**

**U.S. PATENT DOCUMENTS**

D155,609 S \* 10/1949 Hooks ..... D14/214  
D273,008 S 3/1984 Ishizaki  
D317,160 S \* 5/1991 Kurata et al. .... D14/216  
D408,414 S \* 4/1999 Stead et al. .... D14/225  
D449,293 S \* 10/2001 Irby et al. .... D14/219

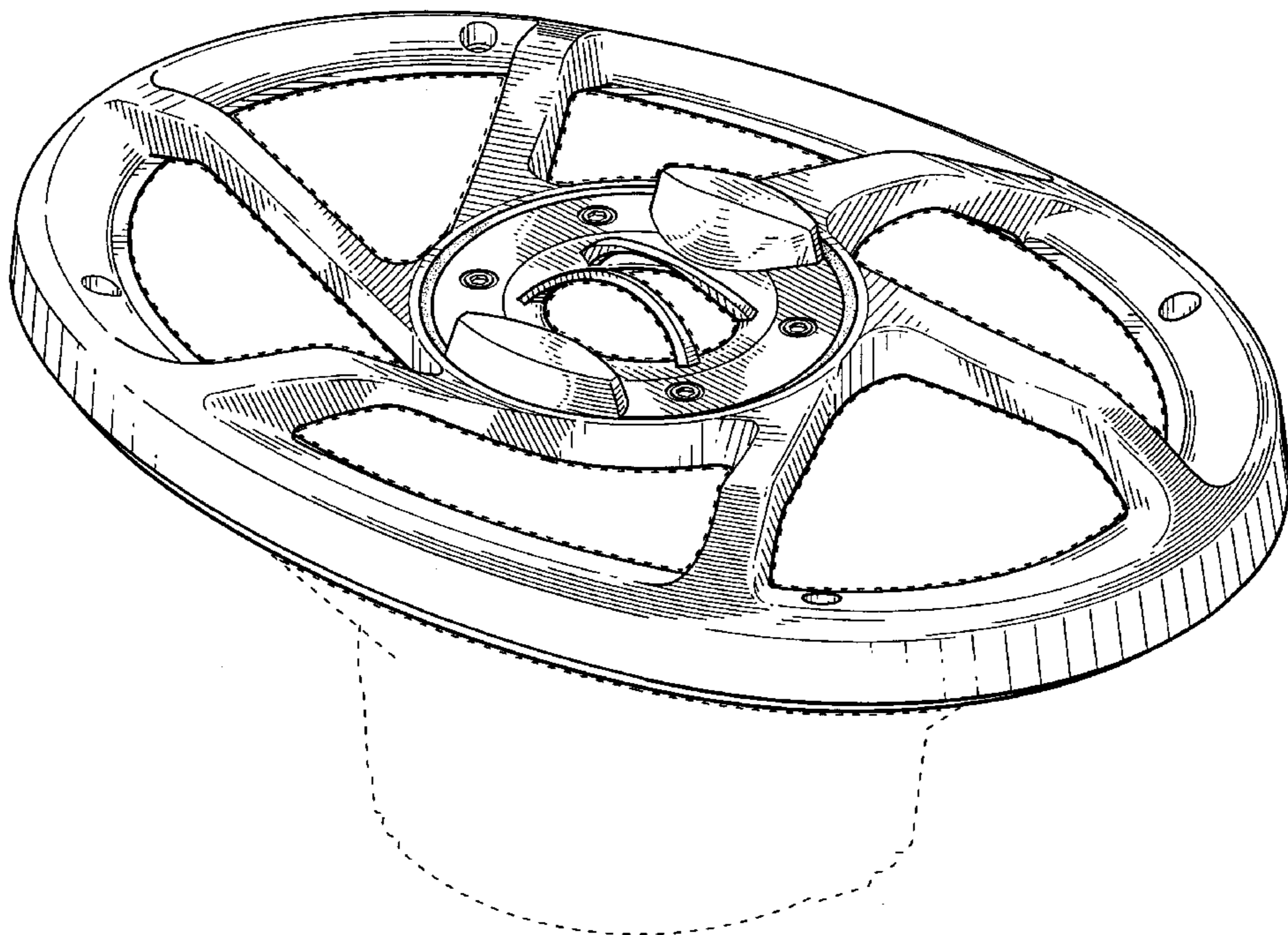
The broken lines showing on the front face of FIGS. 1-2 defines the boundaries of the claimed design and form no part thereof. The remaining broken lines showing the speaker is for illustrative purposes only and form no part of the claimed design.

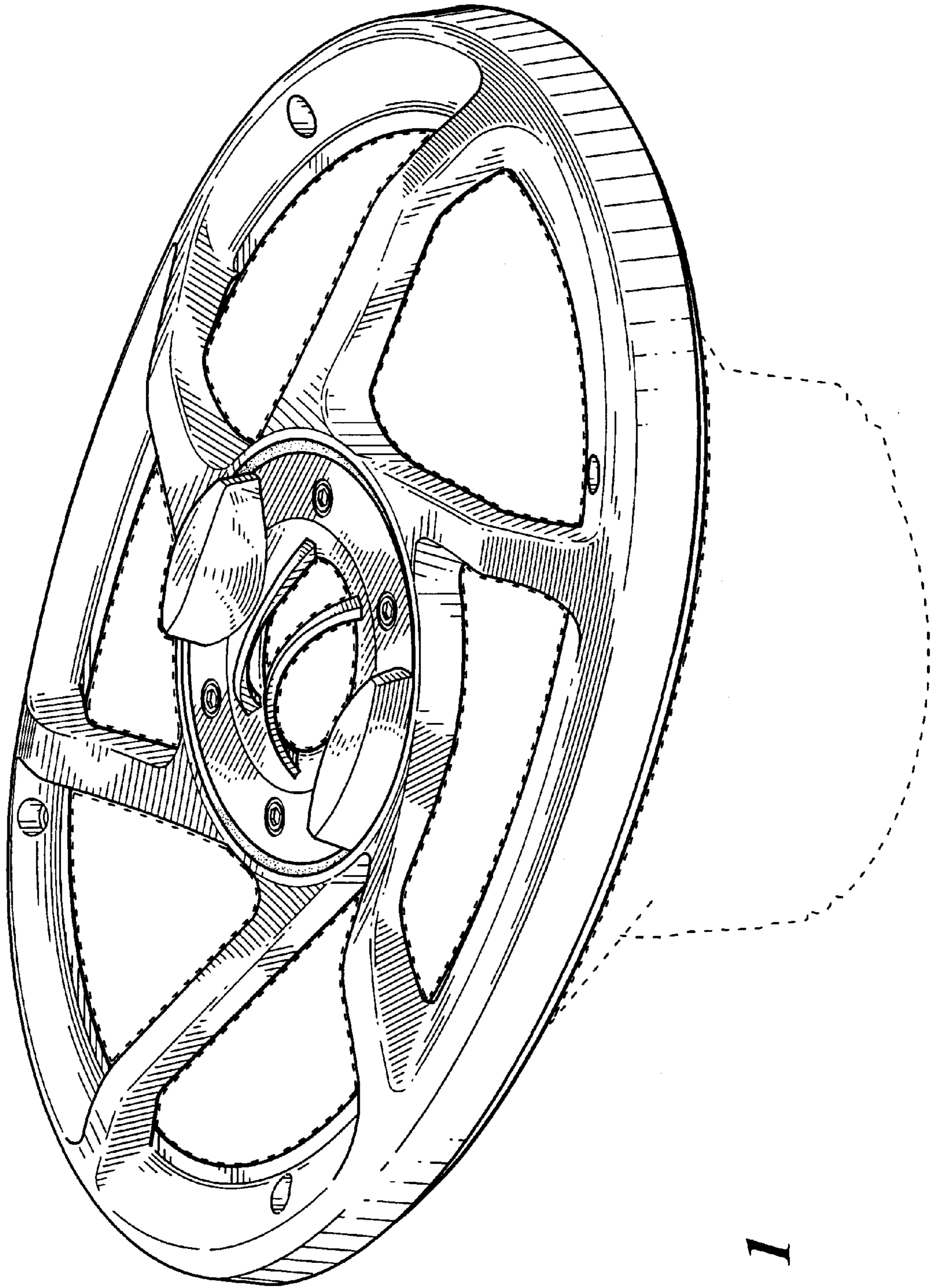
The rear view contains no ornamentality and is therefore omitted.

**FOREIGN PATENT DOCUMENTS**

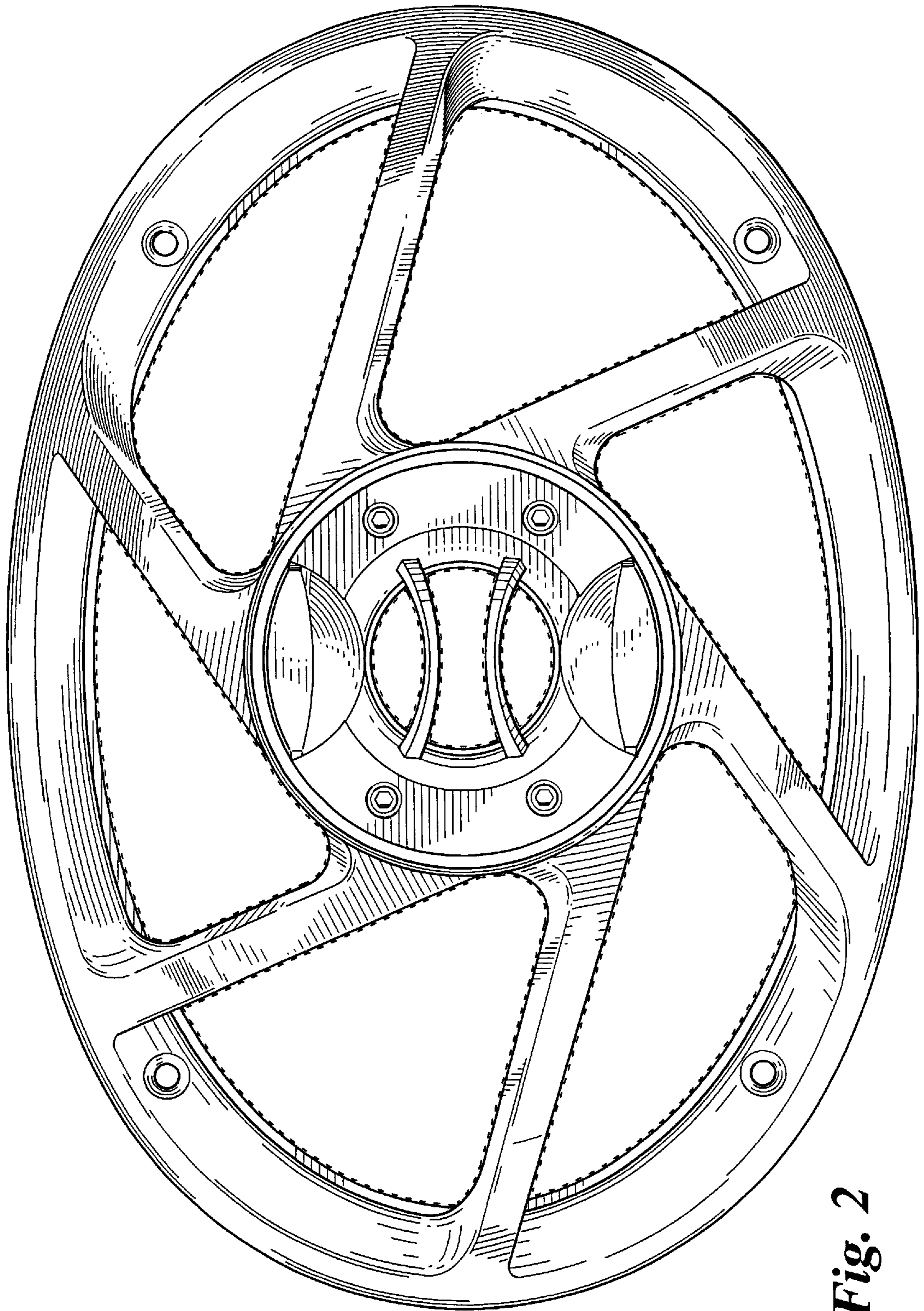
JP 614793 9/1983

**1 Claim, 6 Drawing Sheets**

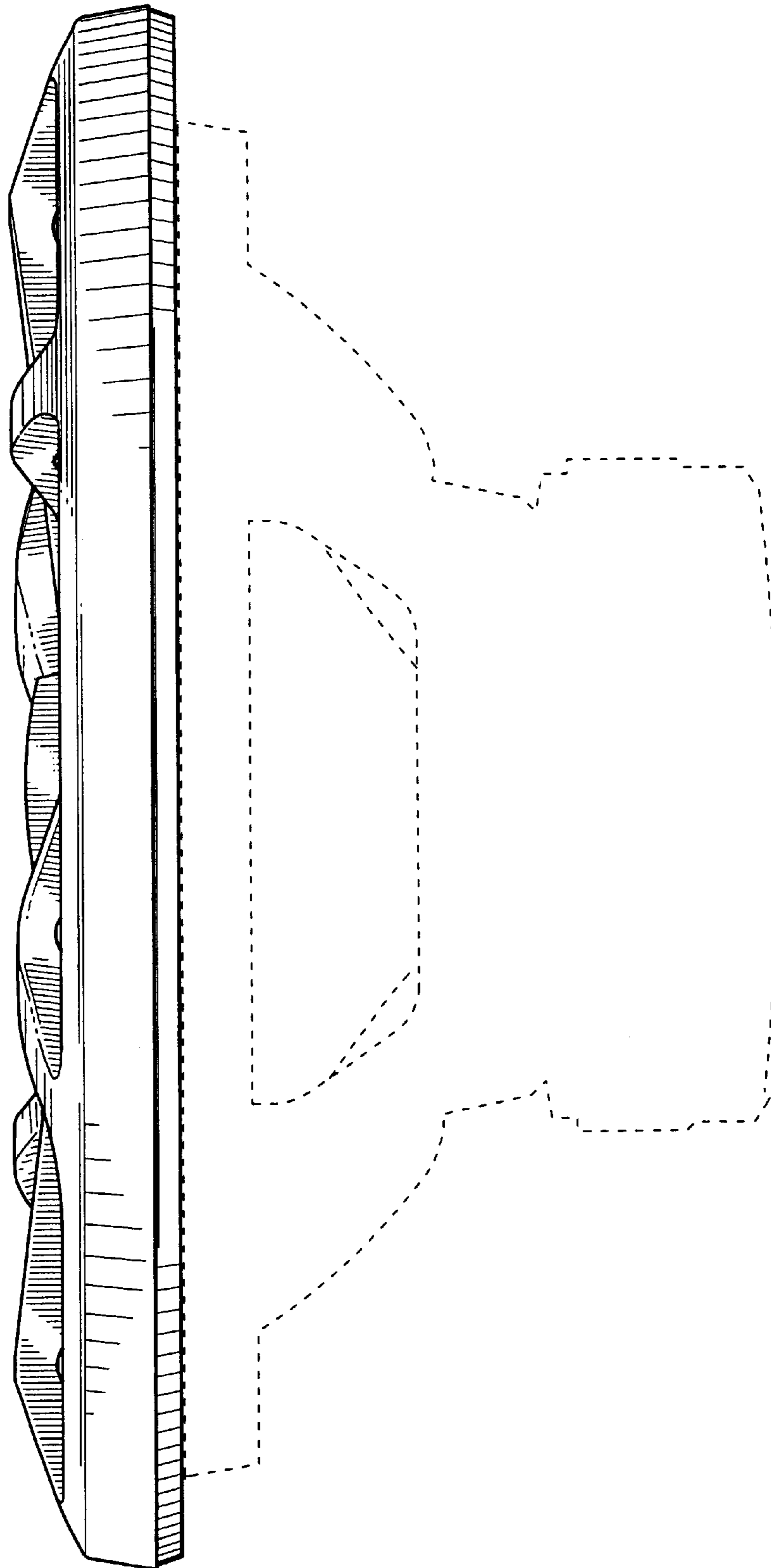




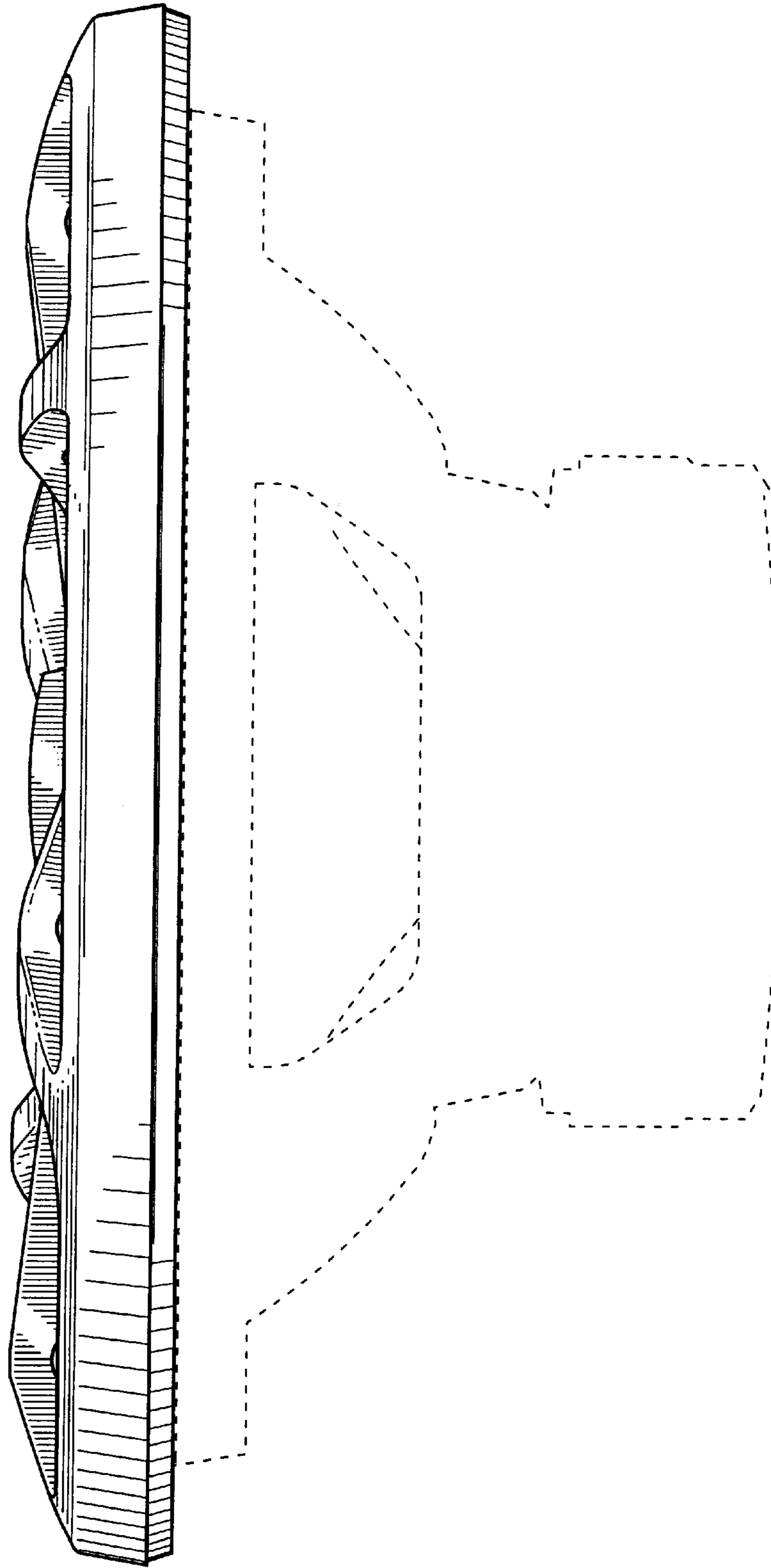
*Fig. 1*



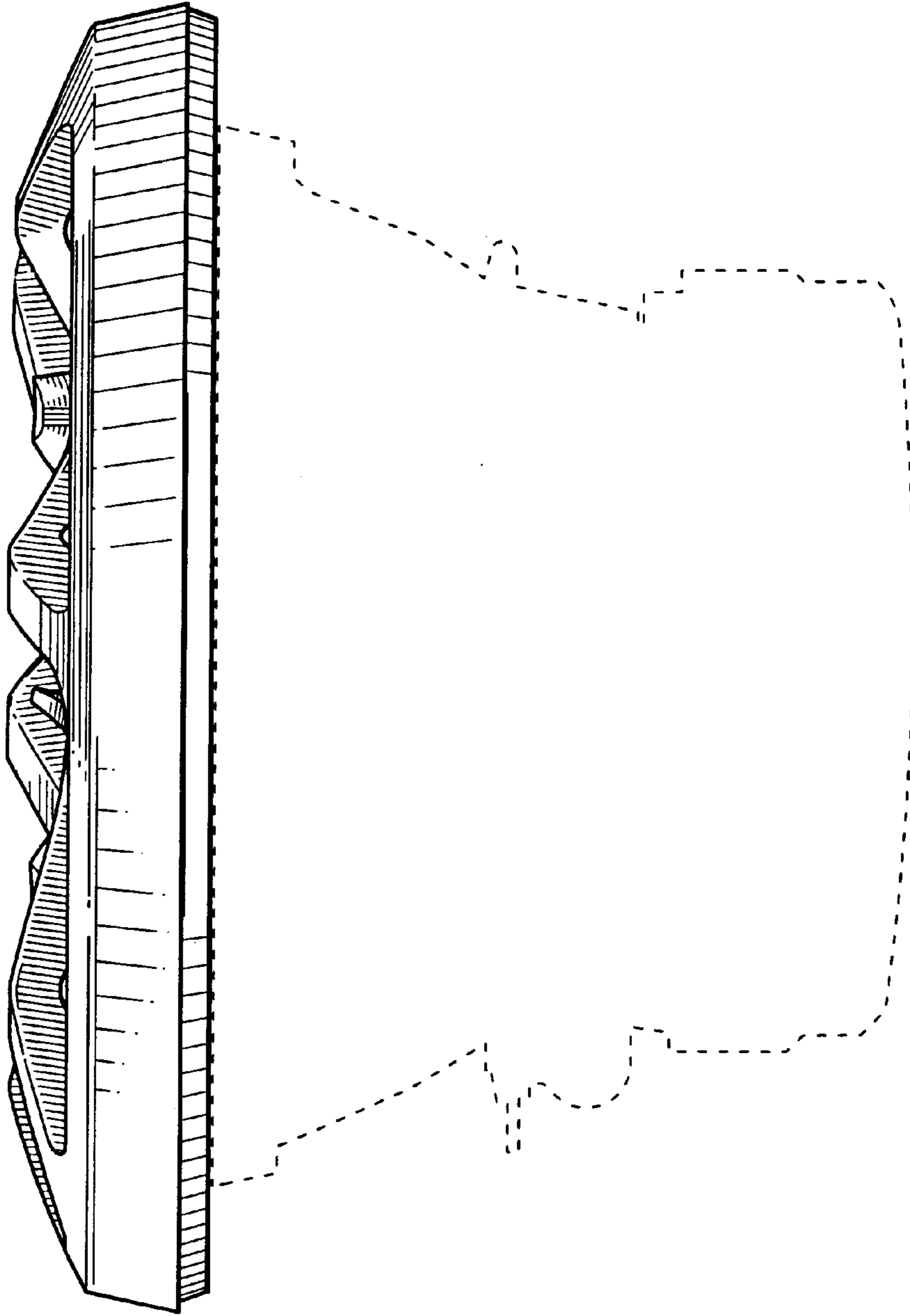
*Fig. 2*



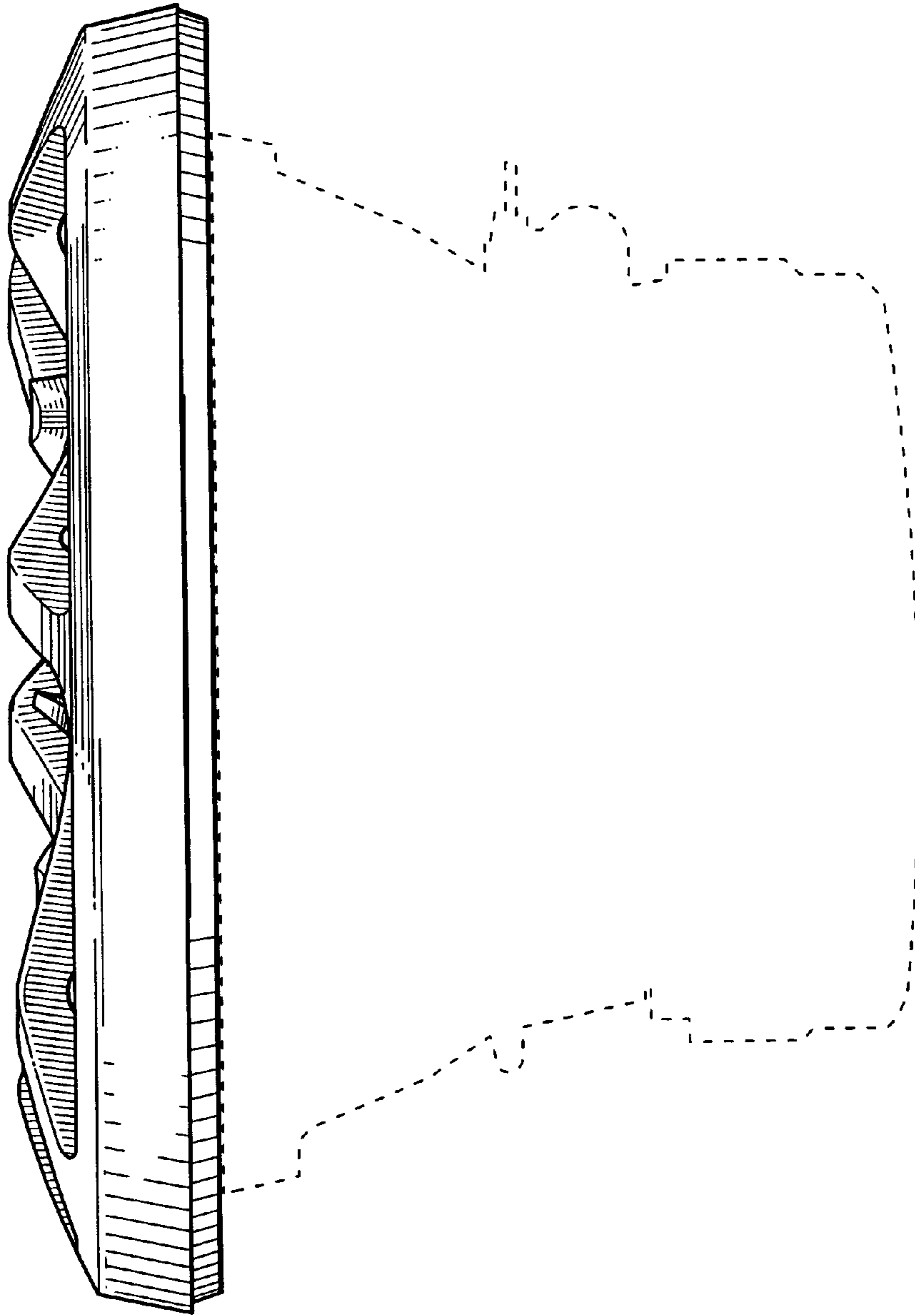
*Fig. 3*



**Fig. 4**



*Fig. 5*



*Fig. 6*