



US00D472529S

(12) **United States Design Patent** (10) **Patent No.:** **US D472,529 S**
Okuyama et al. (45) **Date of Patent:** **** Apr. 1, 2003**

(54) **SEMICONDUCTOR ELEMENT**

(75) Inventors: **Hiroyuki Okuyama**, Tokyo (JP);
Masato Doi, Tokyo (JP); **Goshi Biwa**,
Tokyo (JP); **Toyoharu Oohata**, Tokyo
(JP)

(73) Assignee: **Sony Corporation**, Tokyo (JP)

(**) Term: **14 Years**

(21) Appl. No.: **29/154,047**

(22) Filed: **Jan. 17, 2002**

(51) **LOC (7) Cl.** **13-03**

(52) **U.S. Cl.** **D13/182**

(58) **Field of Search** D13/182; D14/172,
D14/212, 233; 117/95; 216/227; 257/146,
618; 313/309, 310, 327, 336; 369/112.08,
112.09; 438/460

(56) **References Cited**

U.S. PATENT DOCUMENTS

4,685,996	A *	8/1987	Busta et al.	438/20
5,176,557	A *	1/1993	Okunuki et al.	445/24
5,201,681	A *	4/1993	Okunuki et al.	445/24
5,399,238	A *	3/1995	Kumar	216/11
5,482,002	A *	1/1996	Kawade et al.	117/90
5,572,041	A *	11/1996	Betsui et al.	257/10
5,861,707	A *	1/1999	Kumar	313/309
6,051,849	A *	4/2000	Davis et al.	257/103
6,185,013	B1 *	2/2001	Harrington et al.	358/520
6,252,261	B1 *	6/2001	Usui et al.	257/190
6,413,627	B1 *	7/2002	Motoki et al.	428/332

FOREIGN PATENT DOCUMENTS

JP	2830814	12/1998
JP	2000-150391	5/2000
WO	WO 02/07231	1/2002
WO	WO 02/07232	1/2002

OTHER PUBLICATIONS

D. Kapolnek et al., "Spatial control of InGaN luminescence by MOCVD selective epitaxy," *Journal of Crystal Growth*, vols. 189/190, pp. 83–86, Elsevier Science (1998).

J. Wang et al., "Fabrication of nanoscale structures of InGaN by MOCVD lateral overgrowth," *Journal of Crystal Growth*, vol. 197, pp. 48–53, Elsevier Science (1999).

W. Yang et al., "Single-crystal GaN pyramids grown on (111) Si substrates by selective lateral overgrowth," *Journal of Crystal Growth*, vol. 204, pp. 270–274, Elsevier Science (1999).

Raj Singh et al., "Selective Area Growth of GaN Directly on (0001) Sapphire by the HVPE Technique," *MRS Internet Journal of Nitride Semiconductor Research*, vol. 3, Article 13, pp. 1–4, The Materials Research Society (1998).

(List continued on next page.)

Primary Examiner—Ted Shooman

Assistant Examiner—Selina Sikder

(74) *Attorney, Agent, or Firm*—Rader, Fishman & Grauer PLLC

(57) **CLAIM**

The ornamental design for a semiconductor element, as shown and described.

DESCRIPTION

FIG. 1 is a top, front perspective view of a semiconductor element showing our new design;

FIG. 2 is a front elevational view thereof;

FIG. 3 is a rear elevational view thereof;

FIG. 4 is a right side elevational view thereof;

FIG. 5 is a left side elevational view thereof;

FIG. 6 is a top plan view thereof; and

FIG. 7 is a front elevational view of another embodiment of a semiconductor element, which is transparent, showing our new design;

FIG. 8 is a rear elevational view thereof;

FIG. 9 is a right side elevational view thereof;

FIG. 10 is a left side elevational view thereof; and,

FIG. 11 is a top plan view thereof, a bottom plan view thereof being a mirror image.

Portions in broken lines are for illustrative purposes only and form no part of claimed design.

1 Claim, 7 Drawing Sheets

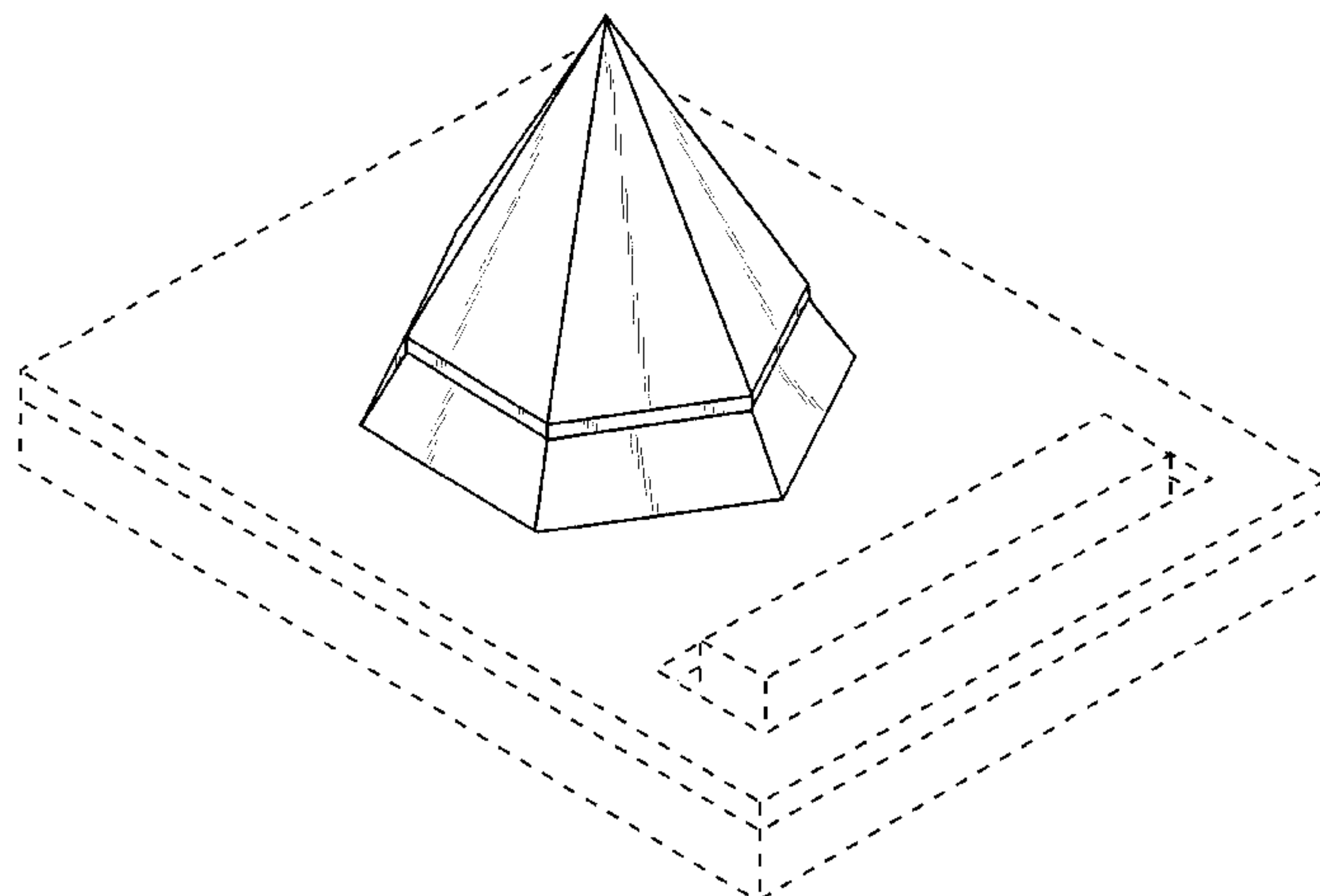

OTHER PUBLICATIONS

Zhigang Mao et al., "Defects in GaN Pyramids Grown on Si (111) Substrates by Selective Lateral Overgrowth," MRS Internet Journal of Nitride Semiconductor Research, vol. 4S1, G3.13, pp. 1-6, The Materials Research Society (1999).

Koichi Tachibana et al., "Selective growth of InGaN quantum dot structures and their microphotoluminescence at

room temperature," Applied Physics Letters, vol. 76, No. 22, pp. 3212-3214 American Institute of Physics (2000).

Takao Someya et al., "Ji-sedai Chikkabutsu Handotai Laser (Next Generation Nitride Semiconductor Laser)," Oyo Butsuri (Applied Physics), vol. 69, No. 10, pp. 1198-1199, (2000) with partial translation.

* cited by examiner

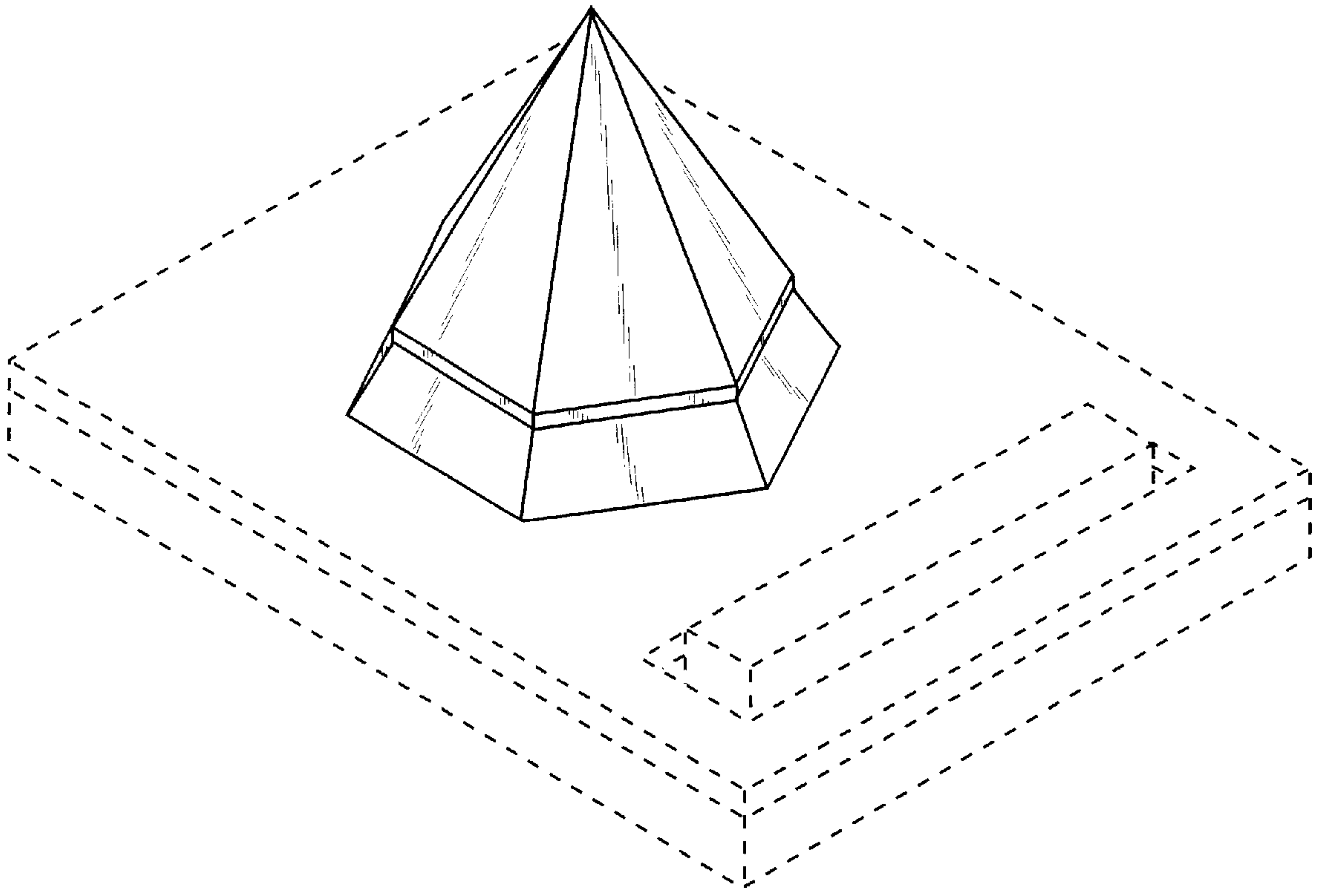

Fig. 1

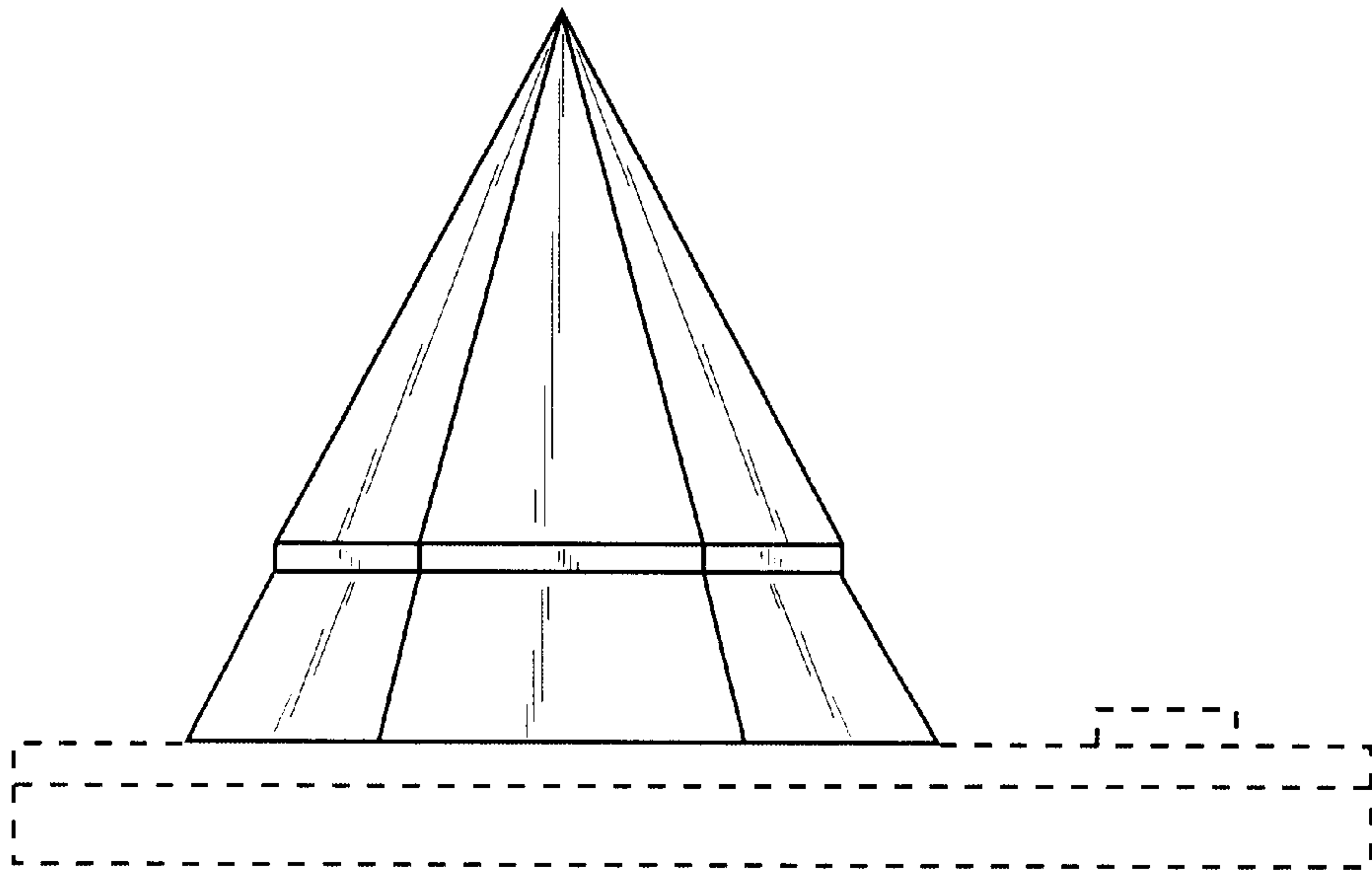

Fig. 2

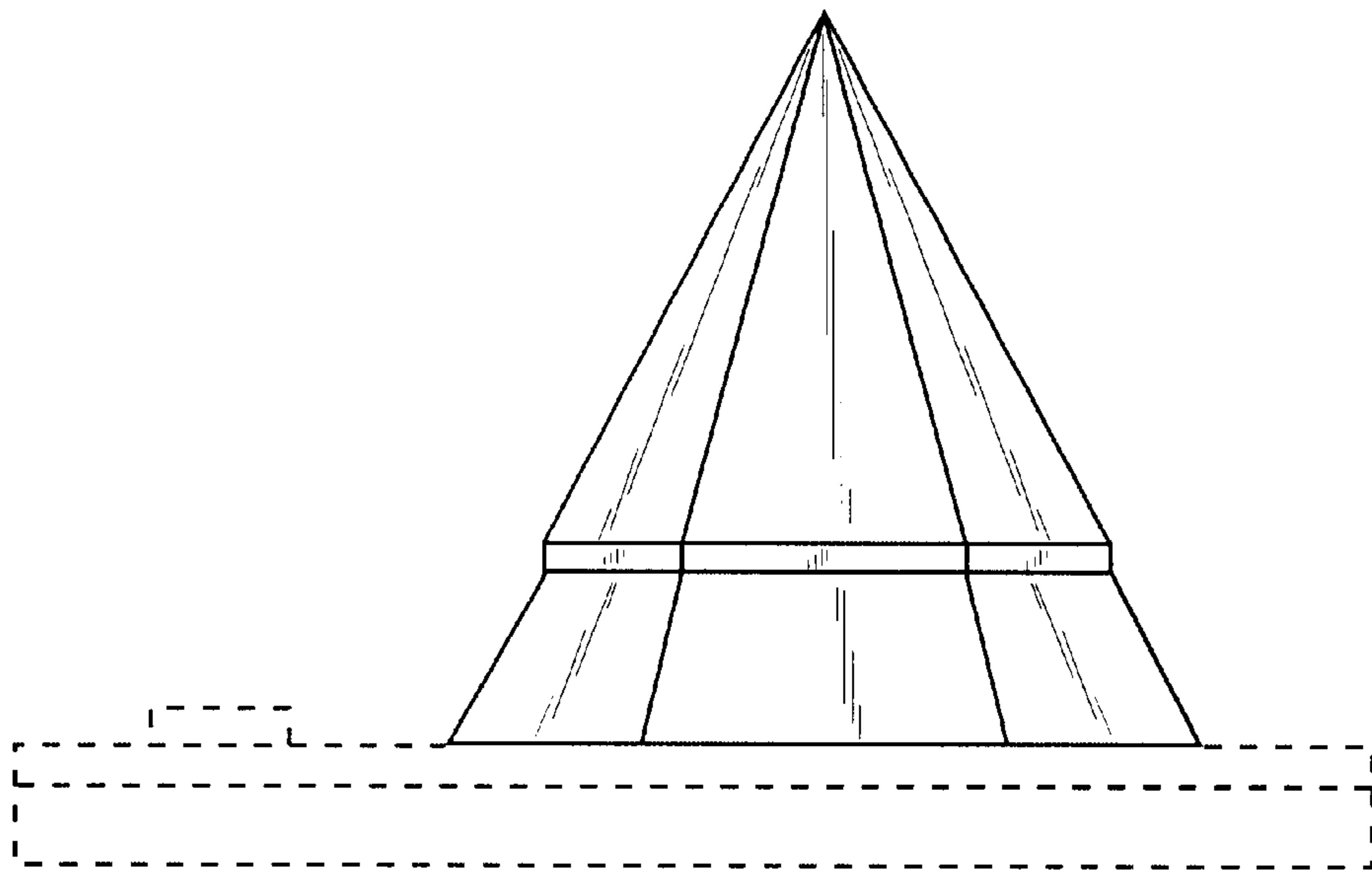

Fig. 3

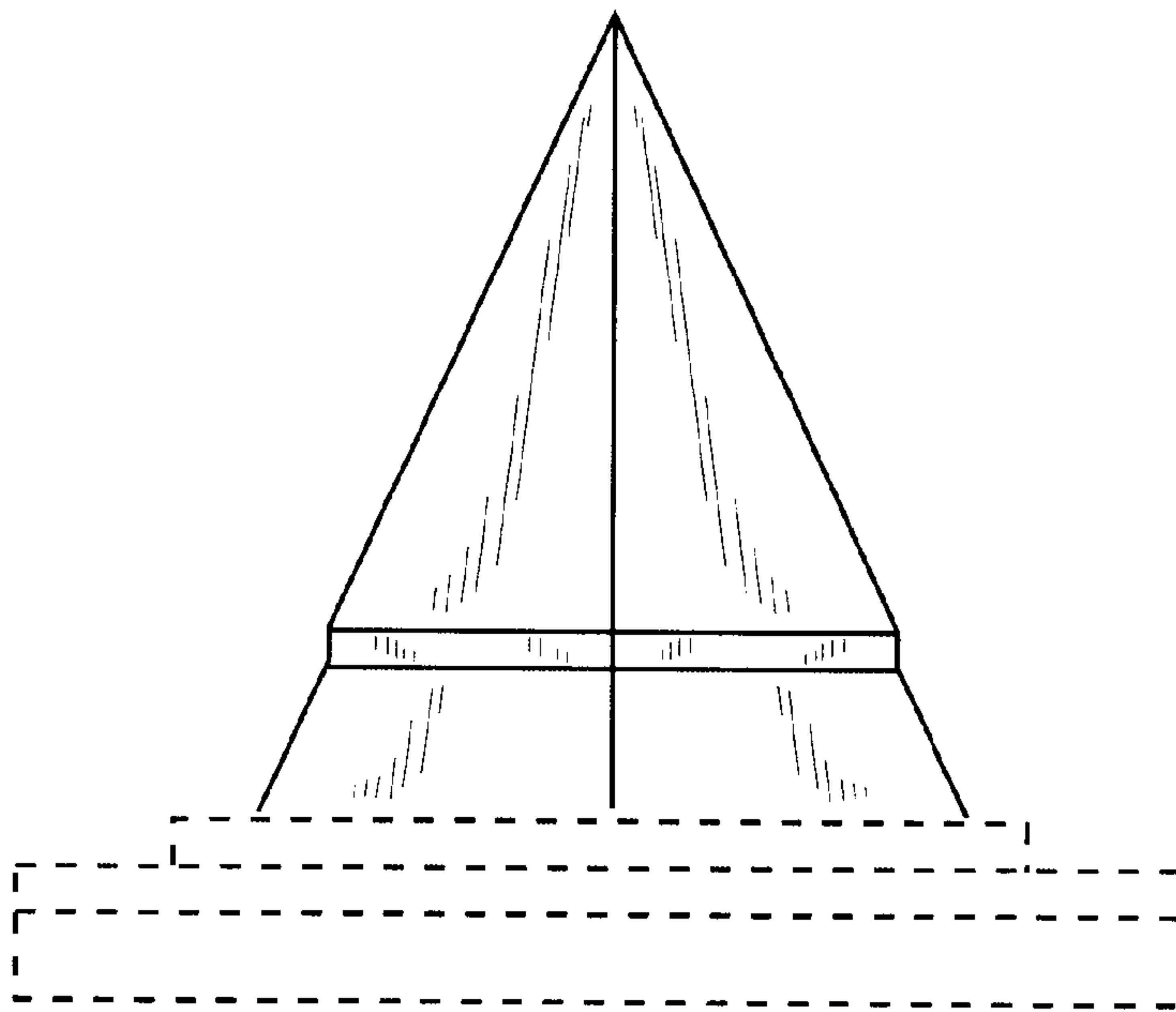

Fig. 4

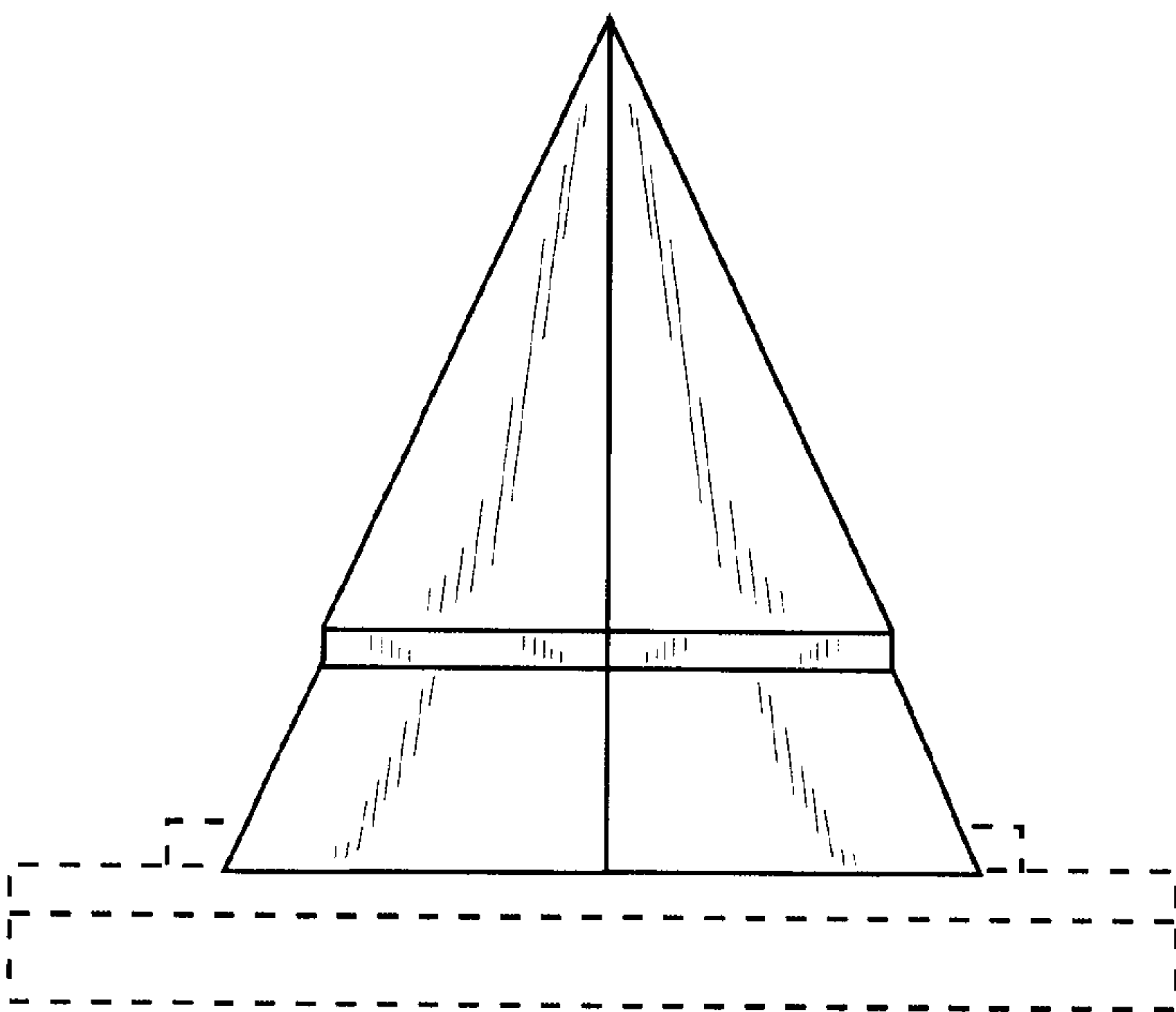

Fig. 5

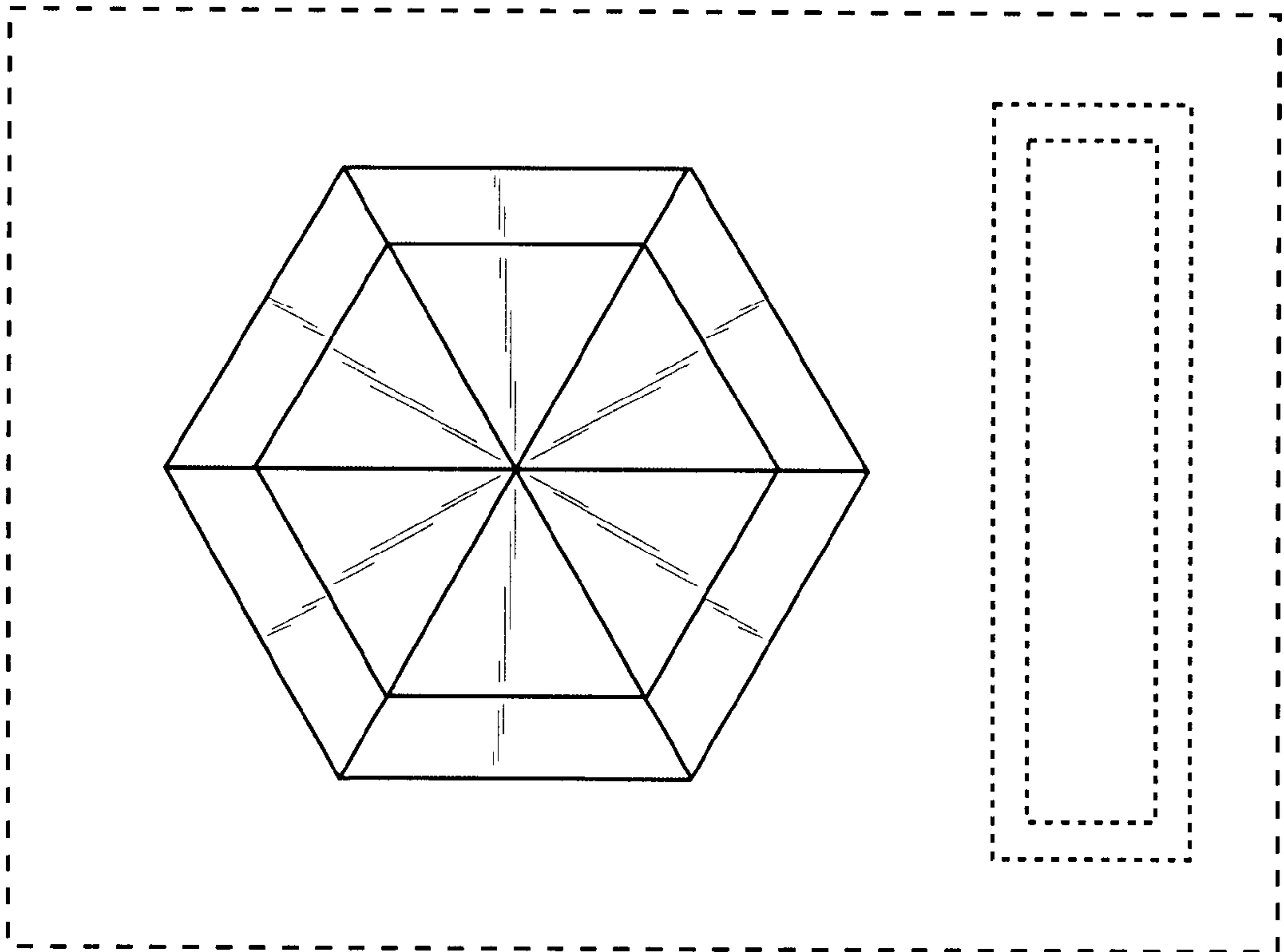

Fig. 6

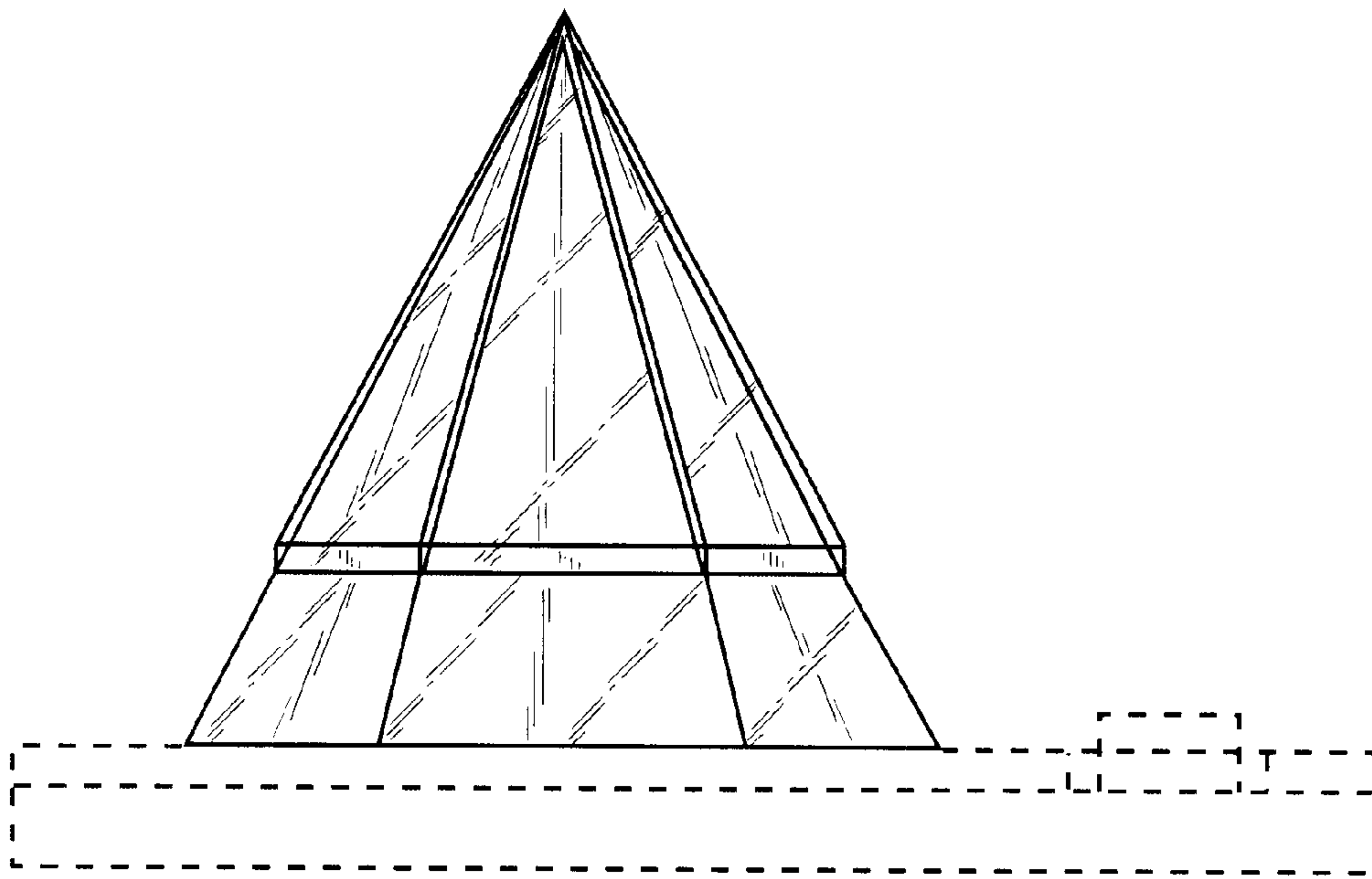

Fig. 7

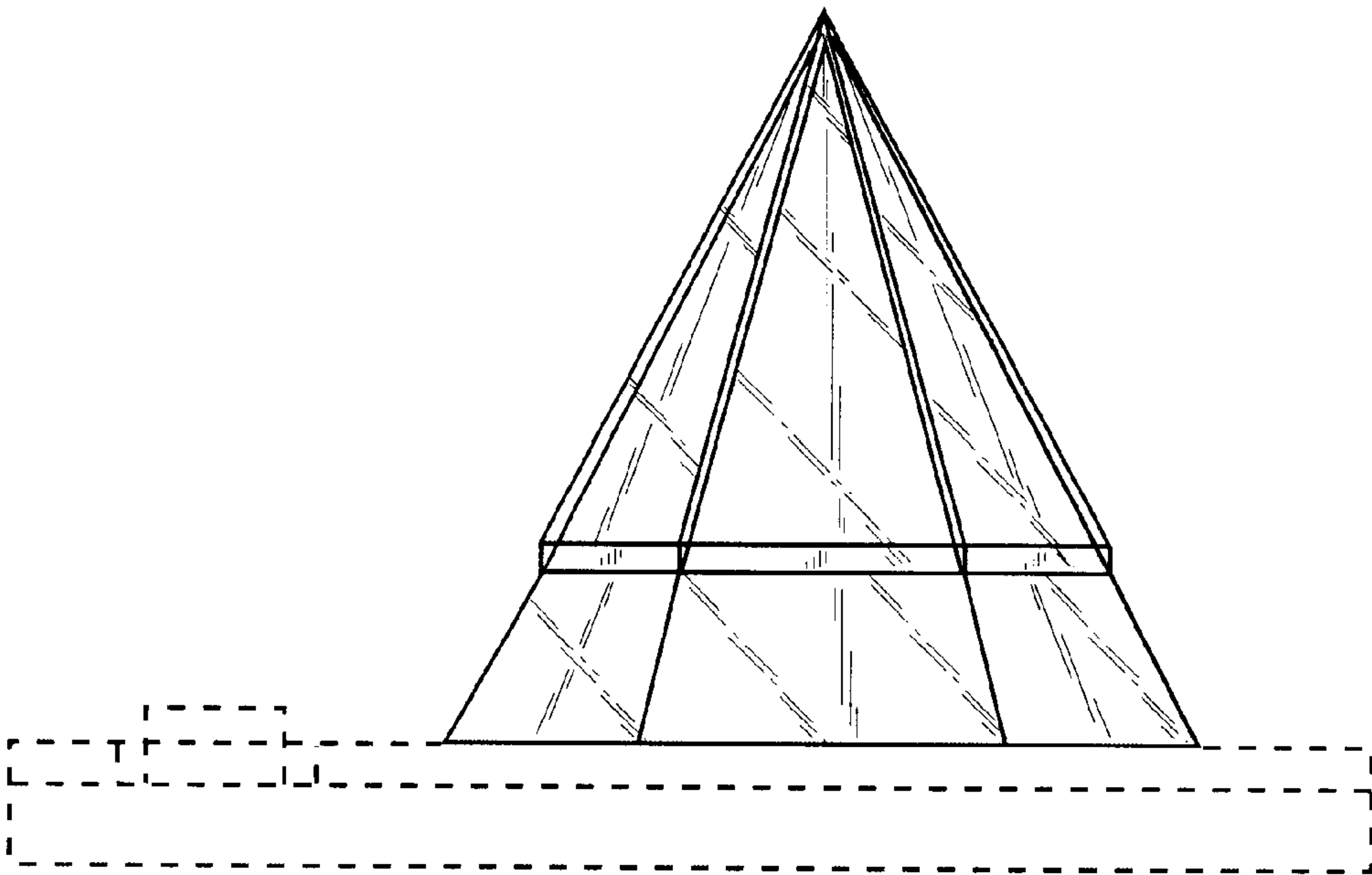

Fig. 8

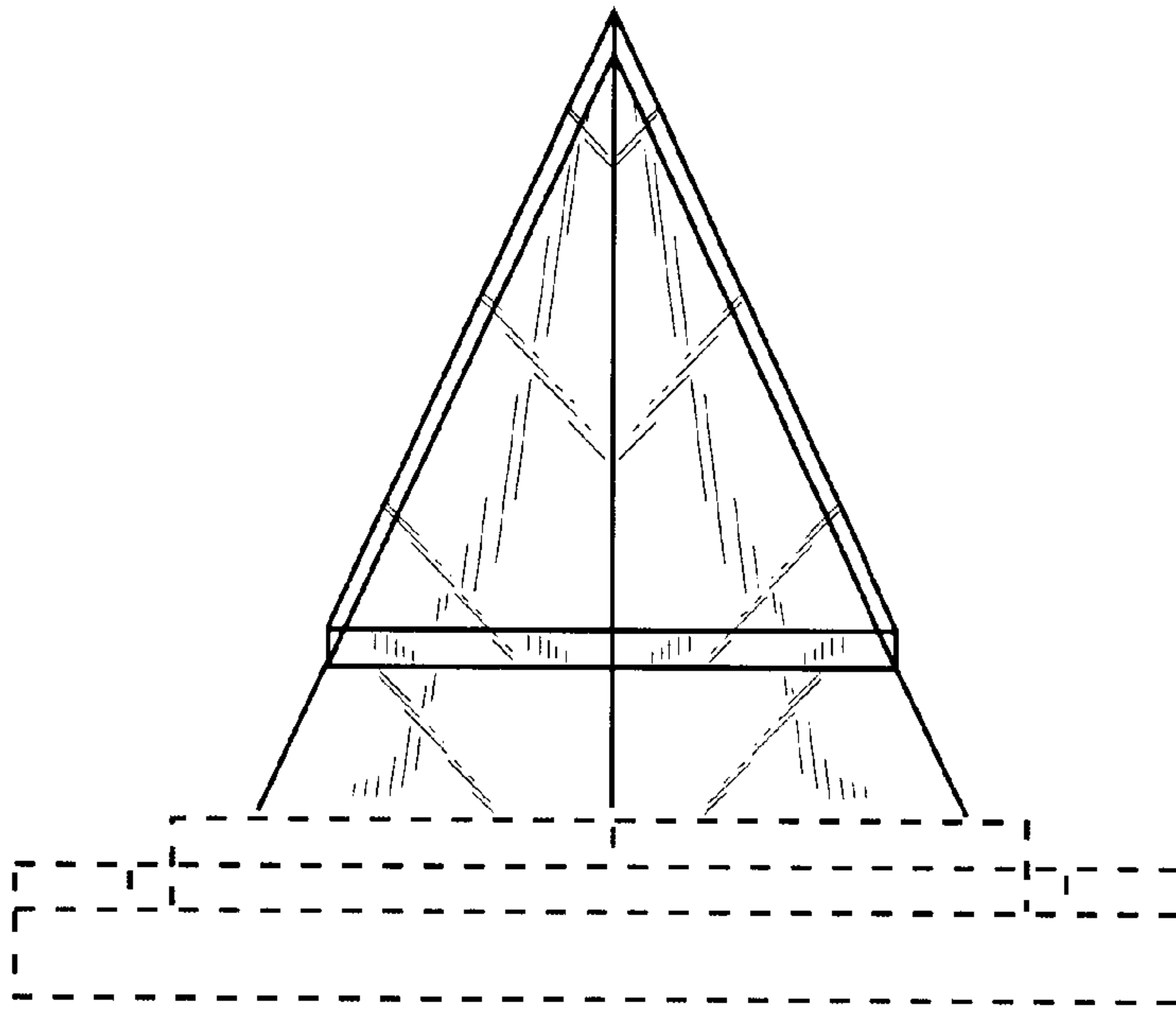

Fig. 9

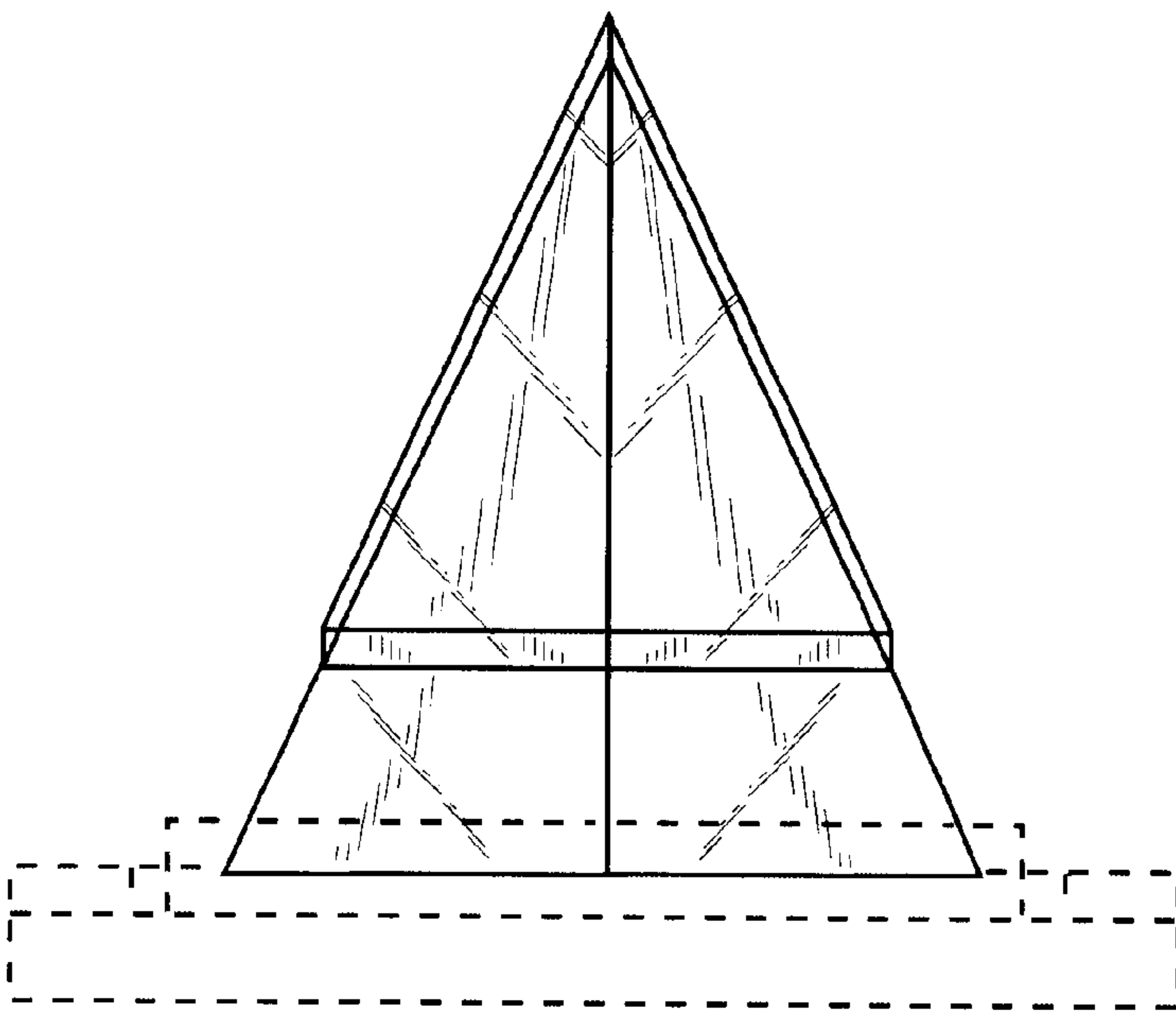

Fig. 10

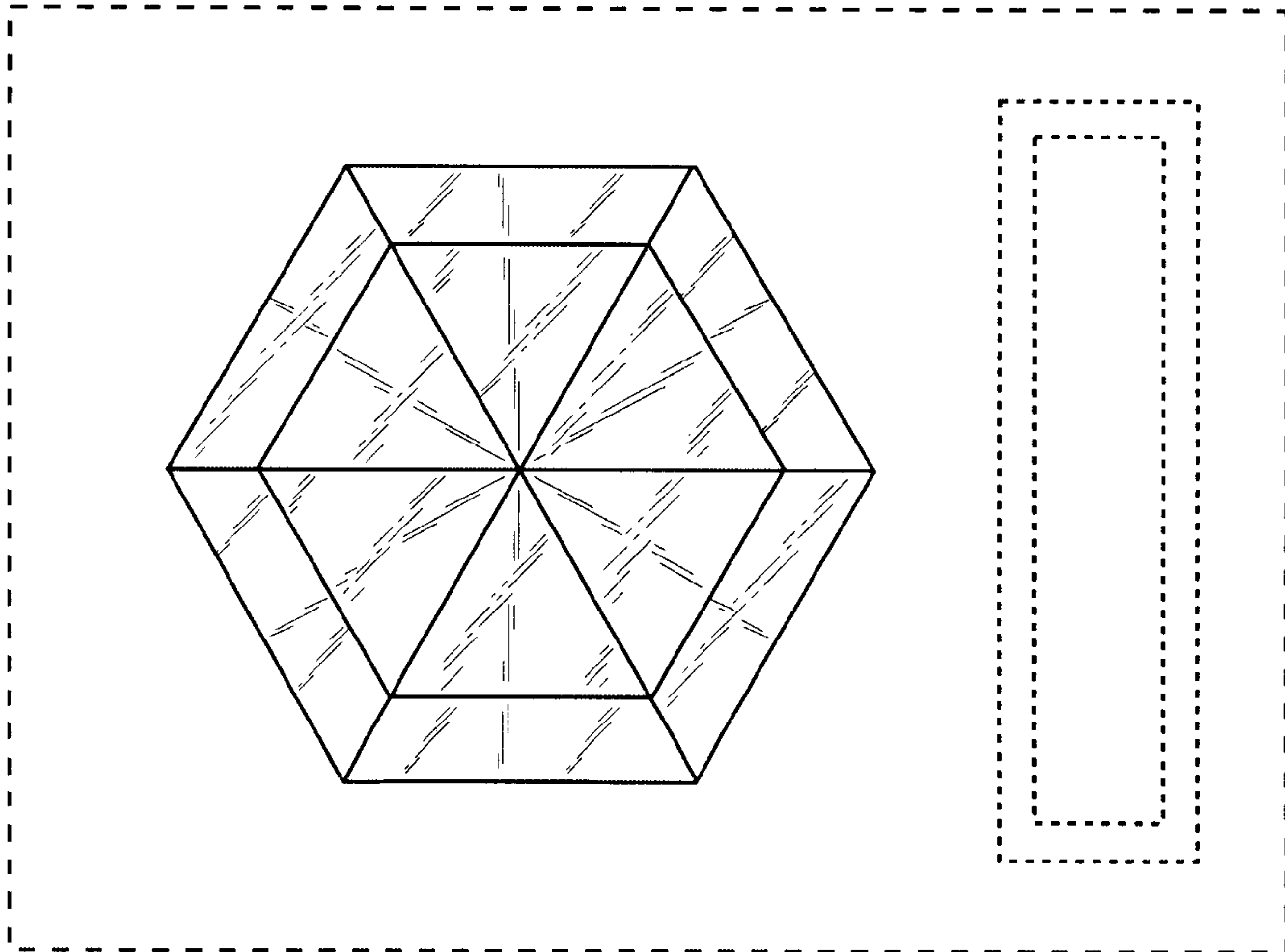

Fig. 11