



US00D472519S

(12) **United States Design Patent**
Buck

(10) **Patent No.:** **US D472,519 S**

(45) **Date of Patent:** **** Apr. 1, 2003**

(54) **PORTABLE ELECTRIC GENERATOR**

(75) **Inventor:** **John E. Buck**, Cockeysville, MD (US)

(73) **Assignee:** **Black & Decker Inc.**, Newark, DE (US)

(**) **Term:** **14 Years**

(21) **Appl. No.:** **29/148,237**

(22) **Filed:** **Sep. 17, 2001**

(51) **LOC (7) Cl. 13-02**

(52) **U.S. Cl. D13/114**

(58) **Field of Search D13/112, 116,**
D13/114; 290/1 A, 1 B; 307/150; 123/2,
3

(56) **References Cited**

U.S. PATENT DOCUMENTS

D135,939 S	7/1943	Worthley	
D194,490 S	1/1963	Winslow	D77/1
D205,975 S	10/1966	Sato	D77/1
D210,937 S	5/1968	Clark	D14/3
D227,411 S	6/1973	De Bella	D13/1
D249,788 S	10/1978	Nanjo	D13/3
4,376,250 A	3/1983	Baker, Jr. et al.	307/150
D276,997 S	1/1985	Mikado	D13/3
D277,285 S	1/1985	Lopez	D15/1
D277,954 S	3/1985	Mizuahima	D13/1
D278,425 S	4/1985	Toshibiko	D13/1
D282,734 S	2/1986	Shibuya	D13/1
D293,904 S	1/1988	Murakami et al.	D13/1
D294,015 S	2/1988	Gomi	D13/1
4,798,082 A *	1/1989	Fujikawa et al.	290/51
4,914,373 A	4/1990	Rivkine	322/1
D382,853 S	8/1997	Crawford	D13/112
D416,537 S	11/1999	Imai et al.	D13/116

D416,858 S	11/1999	Domanski	D13/114
D418,809 S	1/2000	Frank	D13/112
D425,018 S	5/2000	Madura et al.	D13/110
6,181,019 B1	1/2001	Frank	290/1

FOREIGN PATENT DOCUMENTS

DE	M8803611	2/1990	D13/1
DE	9208688	5/1993	D13/1
DE	9301671	9/1993	D13/1
DE	9301672	9/1993	D13/1
DE	9805666	2/1999	D13/1
DE	4990937	7/1999	D13/1
DE	49906955	12/1999	D13/1
DE	40001334	6/2000	D13/1
DE	40003903	9/2000	D13/1

* cited by examiner

Primary Examiner—Lisa Lichtenstein

(74) *Attorney, Agent, or Firm*—Michael P. Leary; Charles E. Yocum; Bruce S. Shapiro

(57) **CLAIM**

The ornamental design for a portable electric generator, as shown and described.

DESCRIPTION

FIG. 1 is a front perspective view of a portable electric generator showing my design.

FIG. 2 is a front elevational view thereof.

FIG. 3 is a rear elevational view thereof.

FIG. 4 is a left side elevational view thereof.

FIG. 5 is a right side elevational view thereof.

FIG. 6 is a top plan view thereof; and,

FIG. 7 is a bottom plan view thereof.

The broken lines show environmental structure in FIGS. 1-7 and form no part of the claimed design.

1 Claim, 7 Drawing Sheets

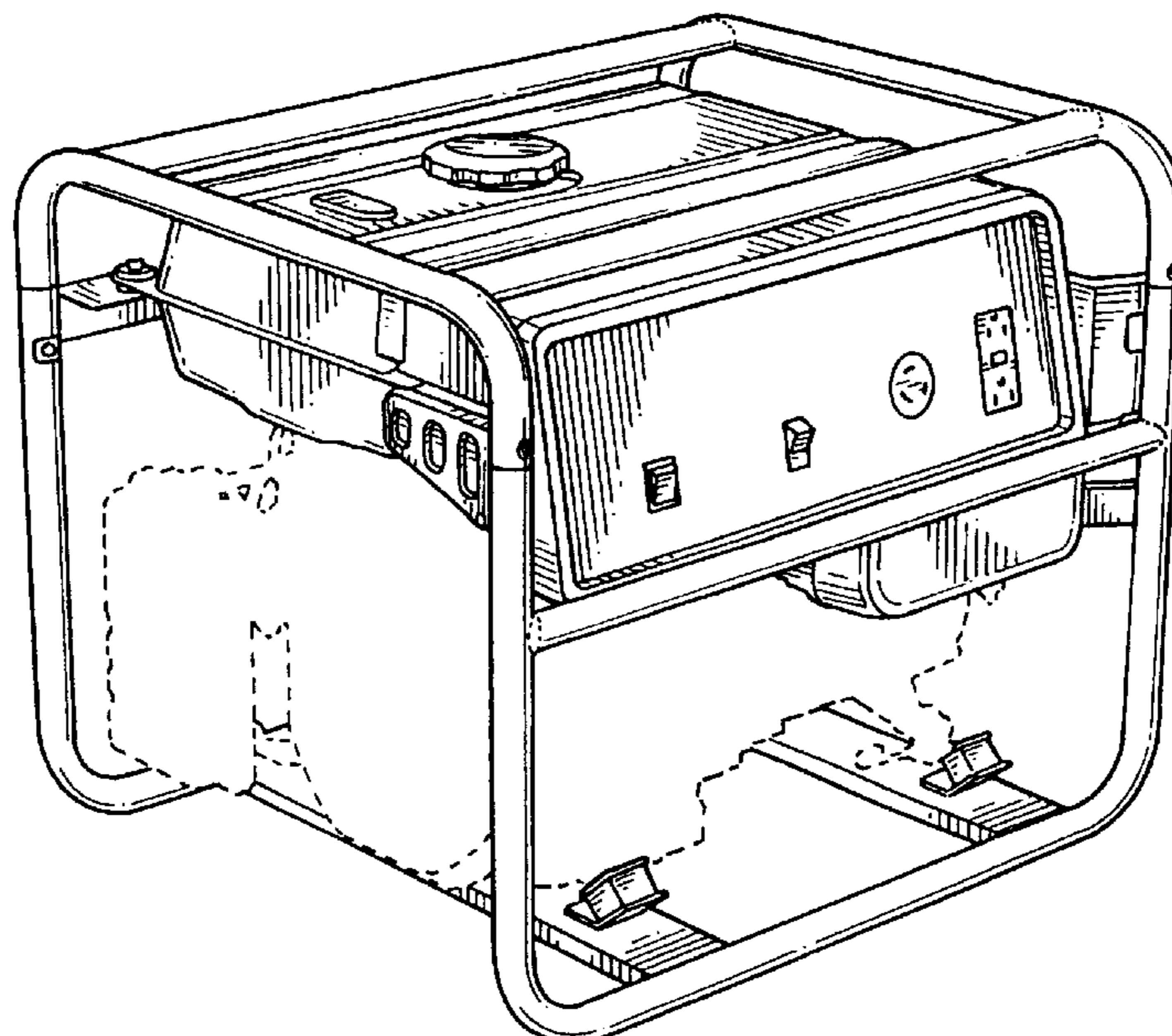

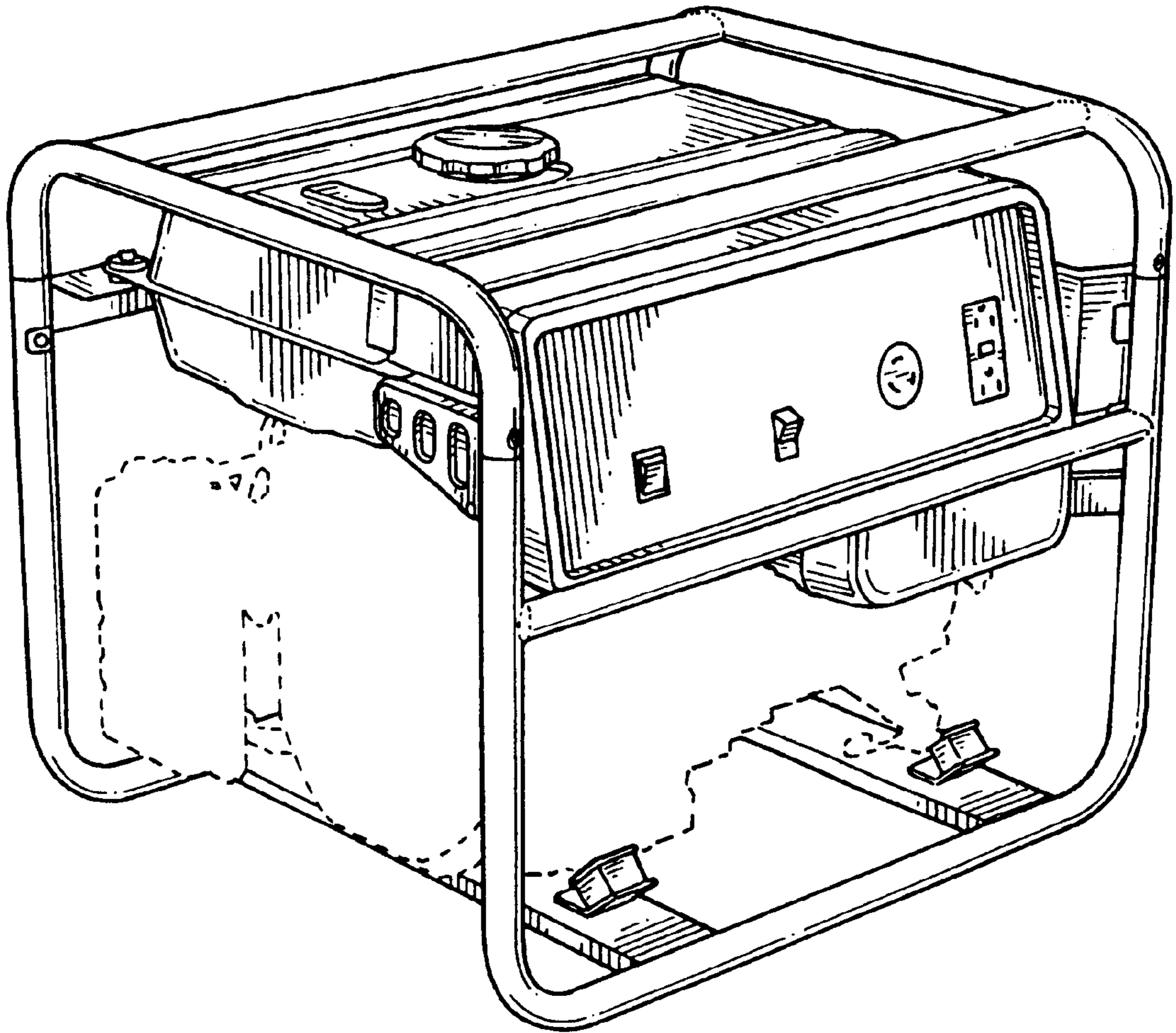

FIG. 1

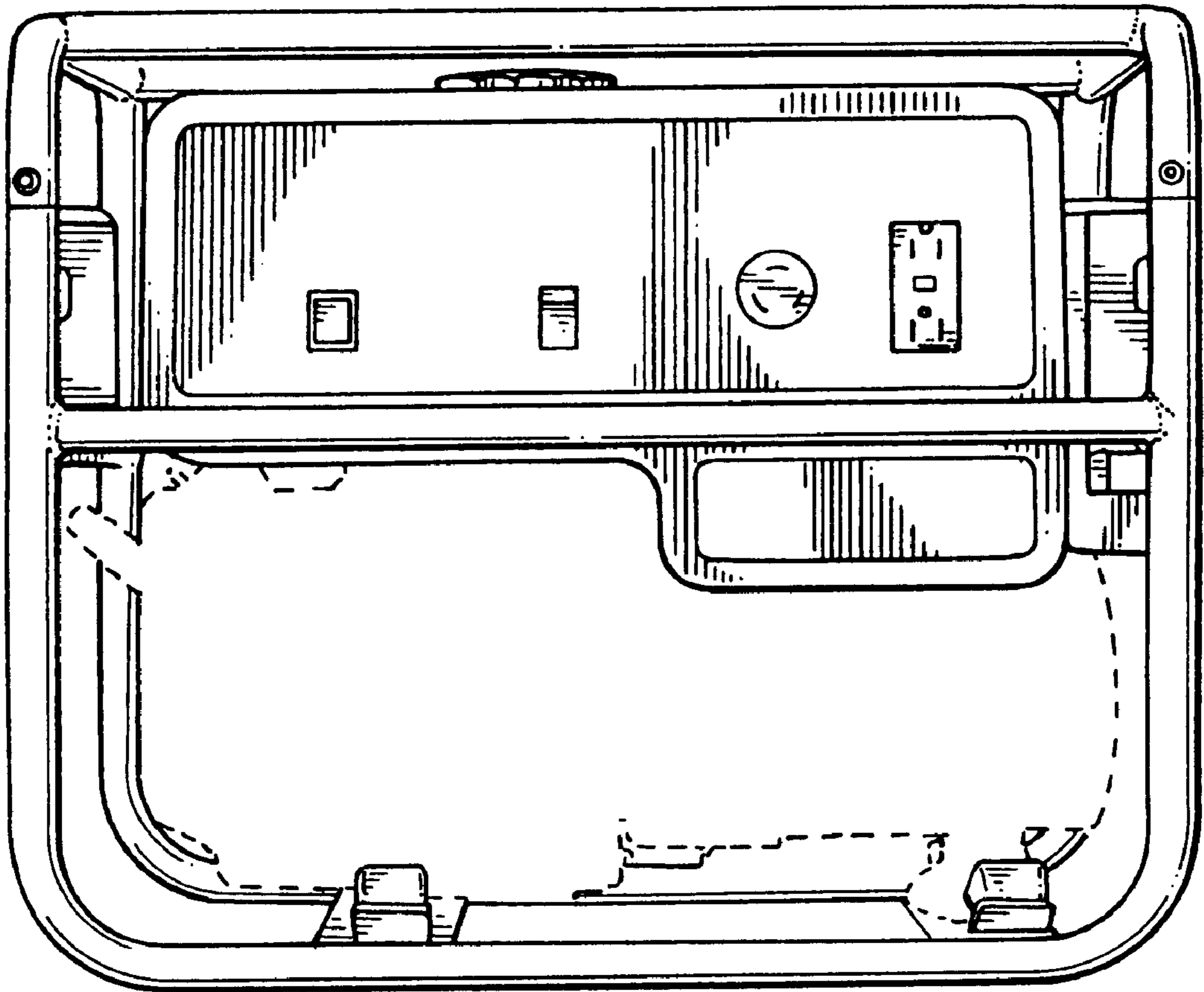

FIG. 2

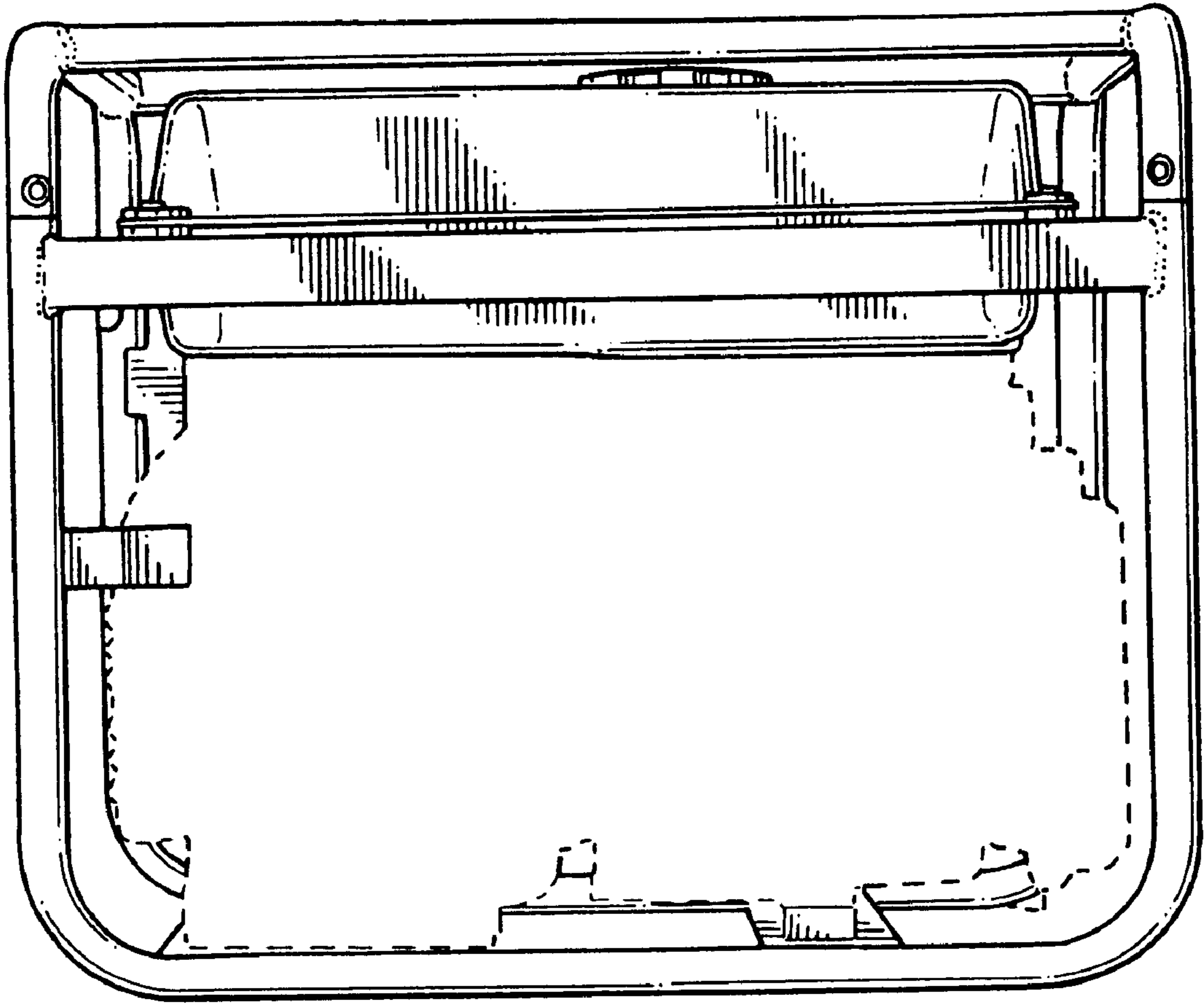

FIG. 3

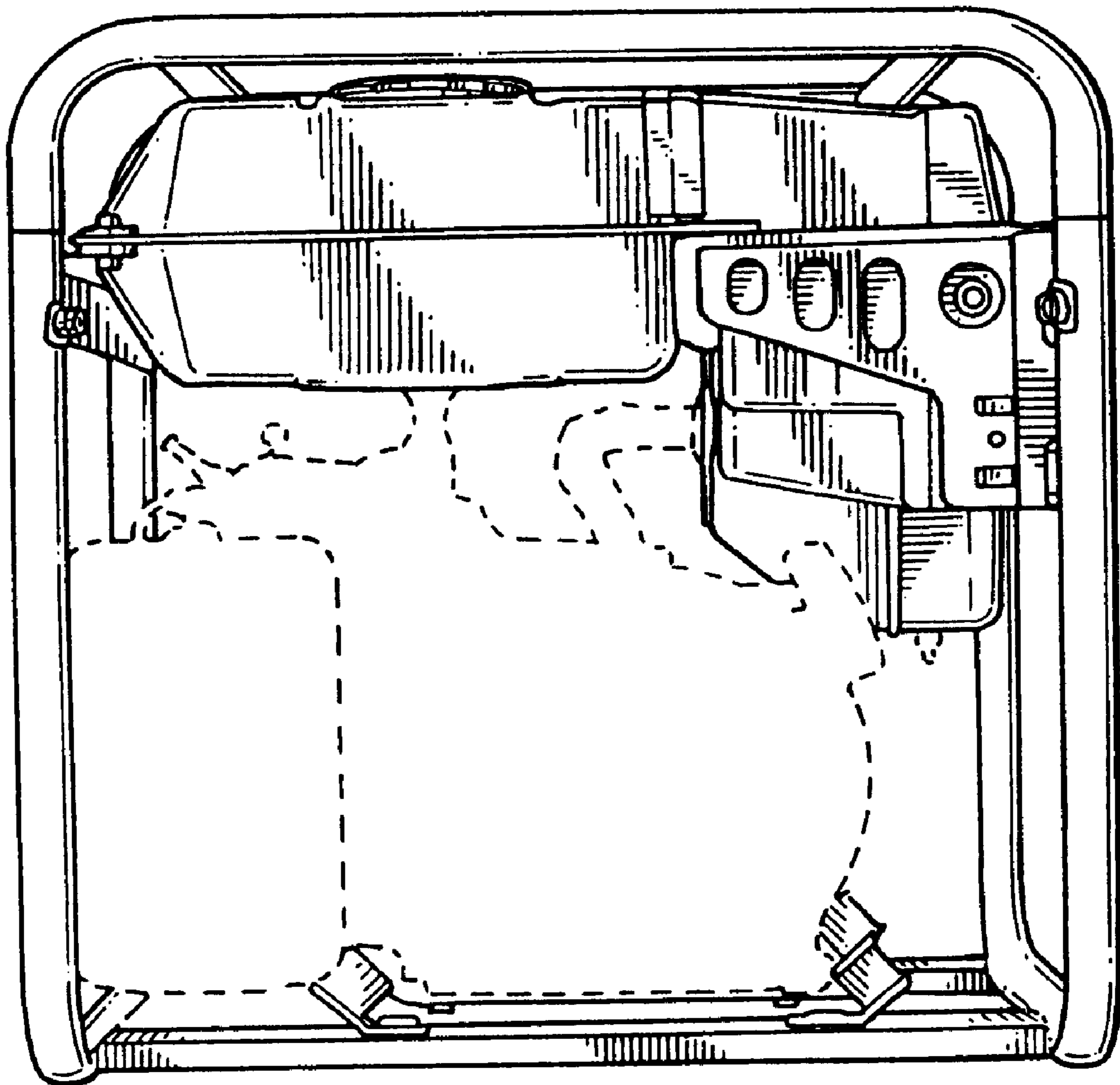

FIG. 4

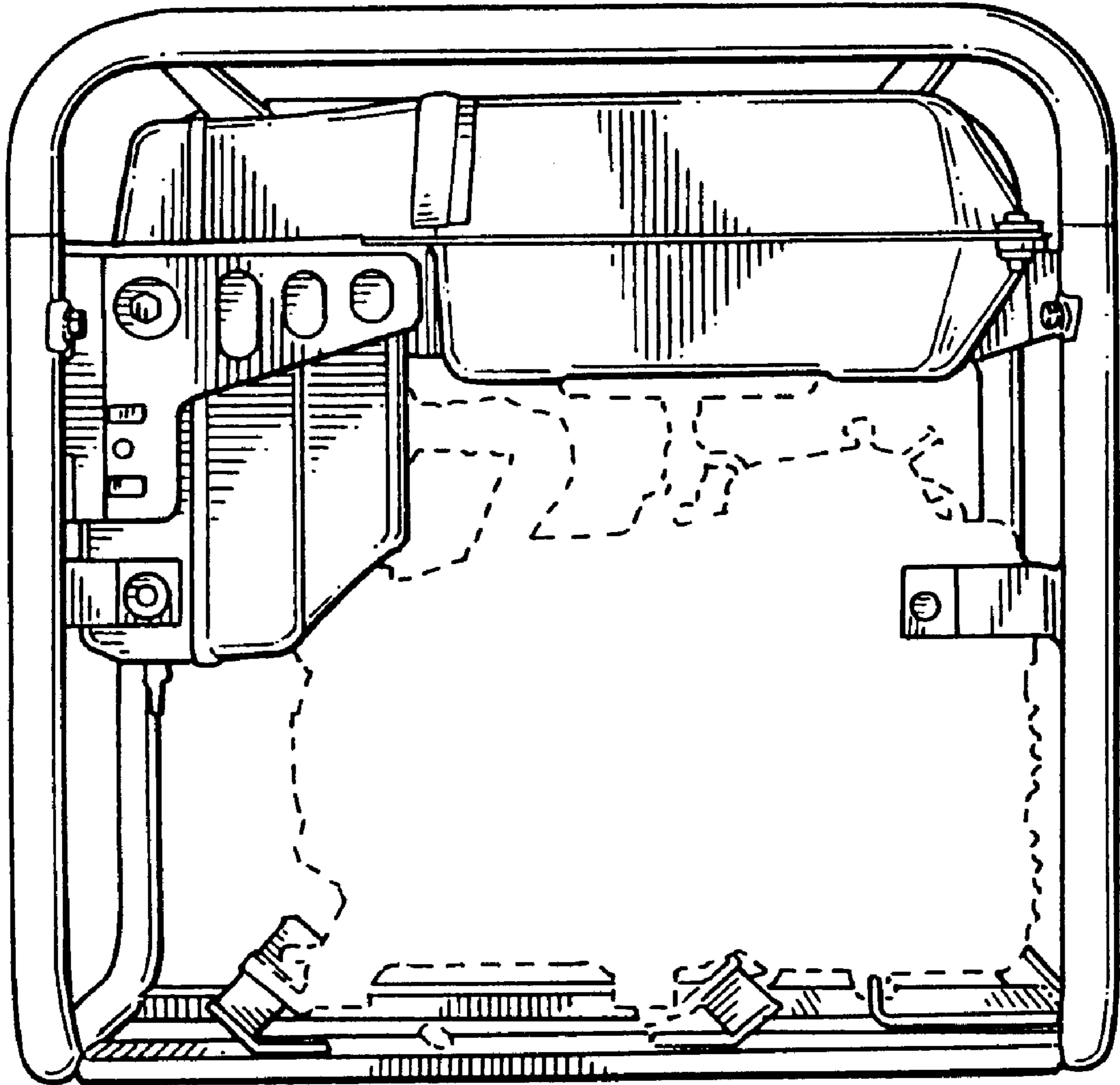

FIG. 5

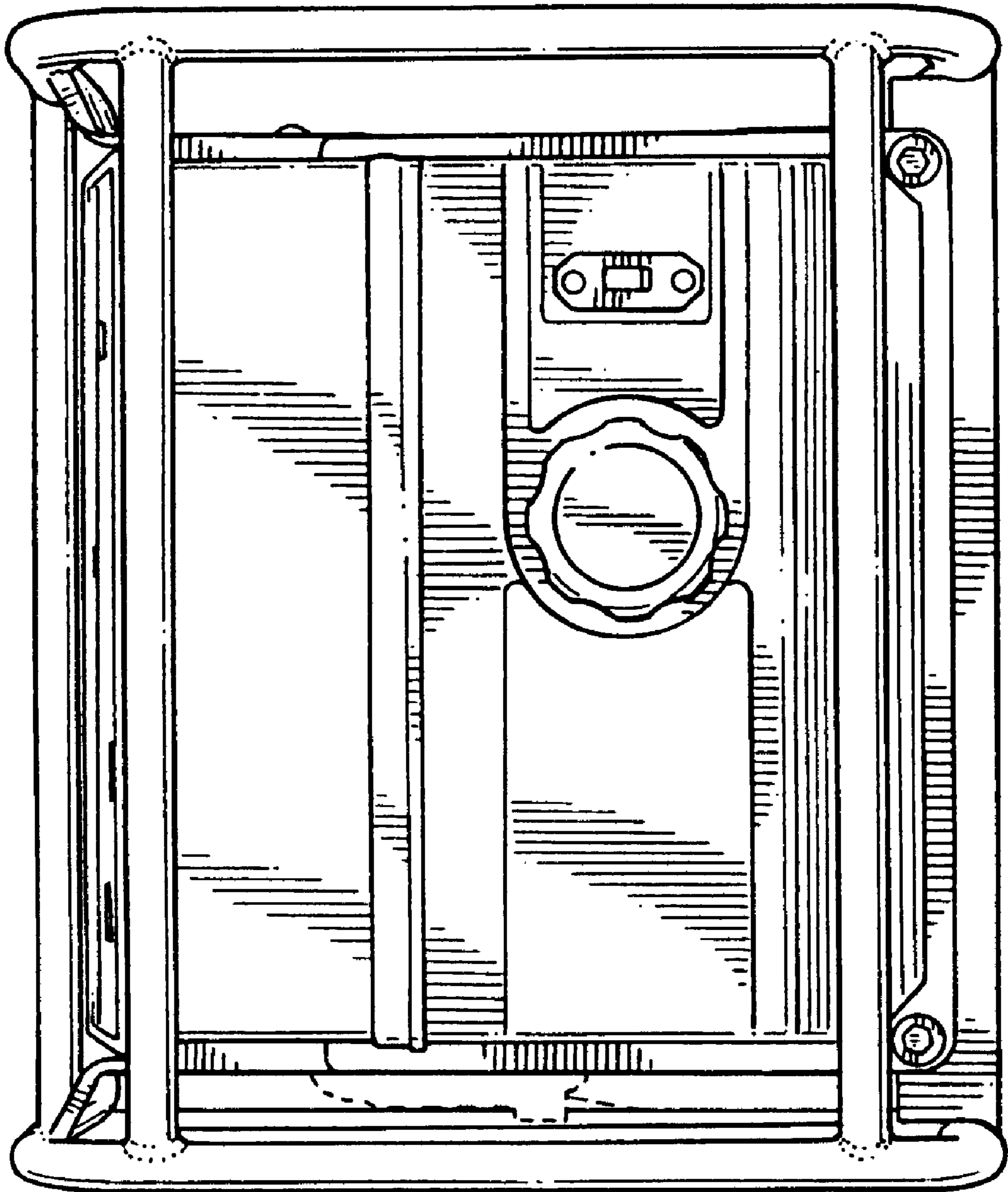

FIG. 6

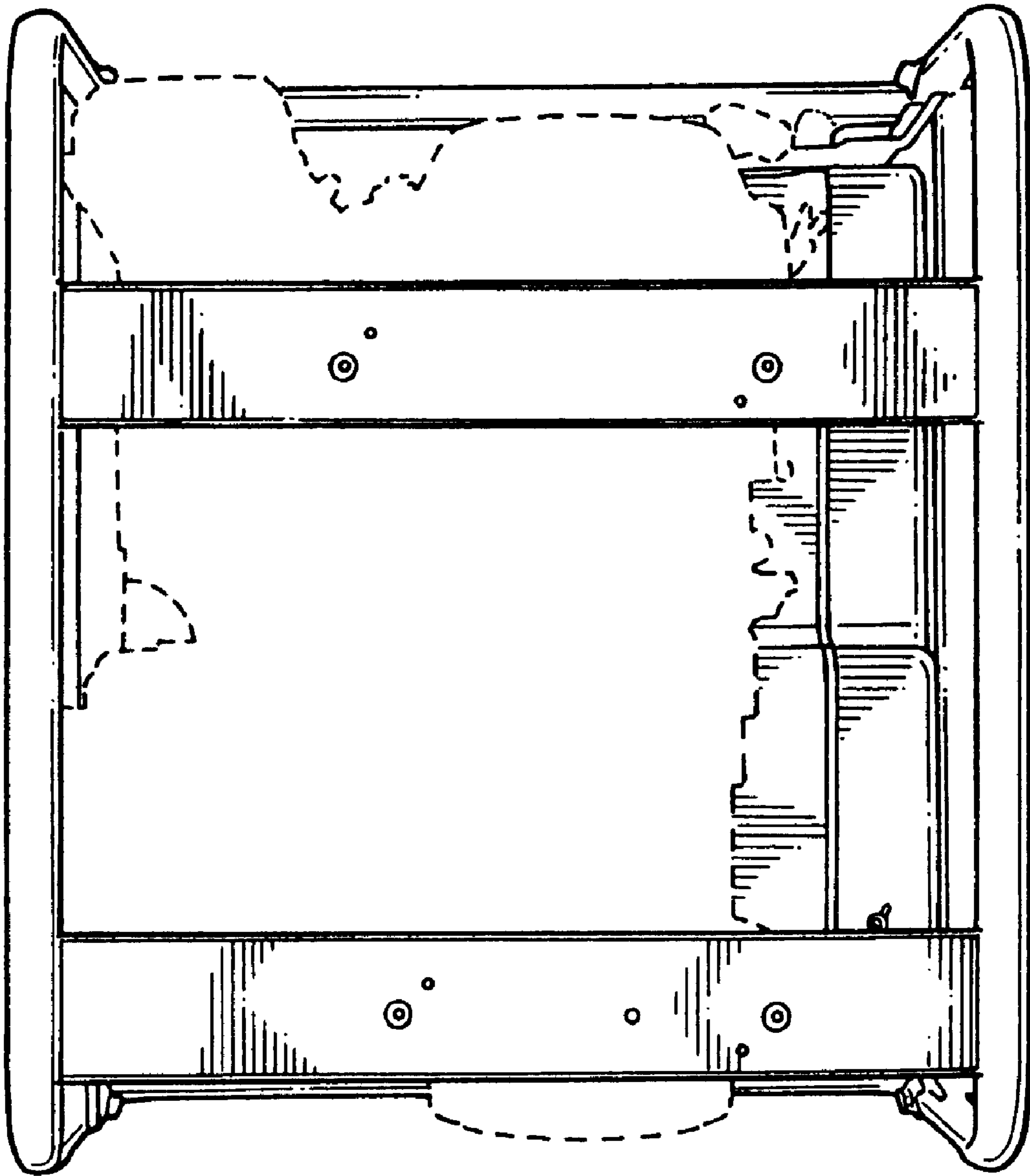

FIG. 7