



US00D472502S

(12) **United States Design Patent**
Rondeau et al.

(10) **Patent No.:** **US D472,502 S**

(45) **Date of Patent:** **** Apr. 1, 2003**

(54) **ALL TERRAIN VEHICLE**

D445,363 S * 7/2001 Luh D12/107

(75) Inventors: **Pierre Rondeau**, St-Denis-de-Brompton (CA); **Martin Aubé**, Sherbrooke (CA); **Martin Portelance**, Sherbrooke (CA)

* cited by examiner

Primary Examiner—Melody N. Brown
(74) *Attorney, Agent, or Firm*—Pillsbury Winthrop LLP

(73) Assignee: **Bombardier Inc.**, Valcourt (CA)

(57) **CLAIM**

(**) Term: **14 Years**

The ornamental design of an all terrain vehicle, as shown and described.

(21) Appl. No.: **29/127,281**

DESCRIPTION

(22) Filed: **Aug. 4, 2000**

(51) **LOC (7) Cl.** **12-11**

(52) **U.S. Cl.** **D12/107**

(58) **Field of Search** D12/107, 3, 1,
D12/114; 180/225, 229, 233, 312, 315,
311

FIG. 1 is a front perspective view illustrating an all terrain vehicle according to the present invention, with relevant portions of the all terrain vehicle shown in broken lines; FIG. 2 is a top plan view thereof; FIG. 3 is a right side view thereof; FIG. 4 is a left side view thereof; FIG. 5 is a rear view thereof, with the indication of environmental structure removed; and, FIG. 6 is a front view thereof, with the indication of environmental structure removed.

The broken lines shown in FIGS. 1, 3 and 4 are for illustrative purposes only and form no part of the claimed design.

(56) **References Cited**

U.S. PATENT DOCUMENTS

D405,029 S	2/1999	Deutschman	
D415,448 S	10/1999	Deutschman	
D424,982 S	* 5/2000	Deutschman D12/107
D440,188 S	* 4/2001	Lin D12/107
D441,693 S	* 5/2001	Lessard D12/107

1 Claim, 6 Drawing Sheets

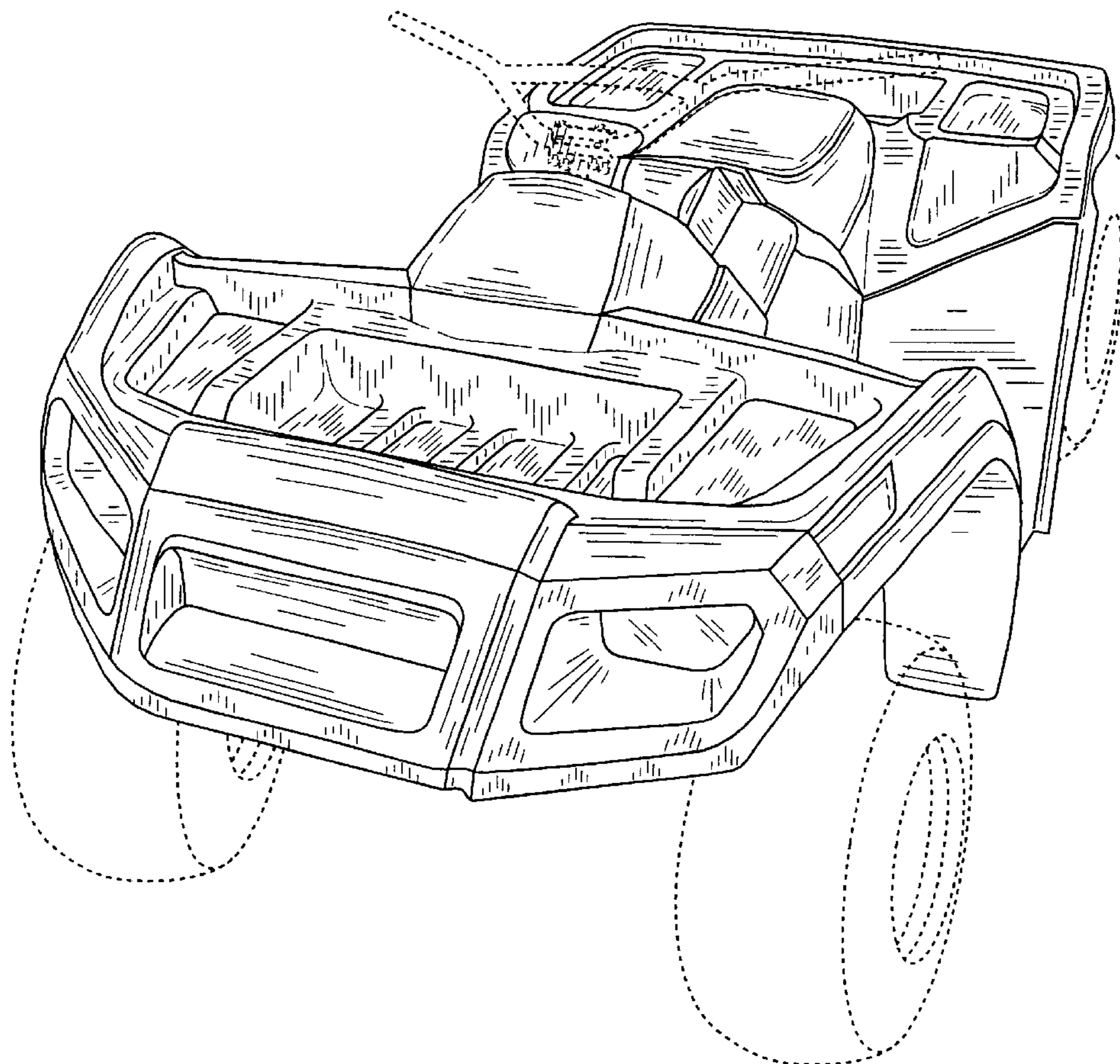

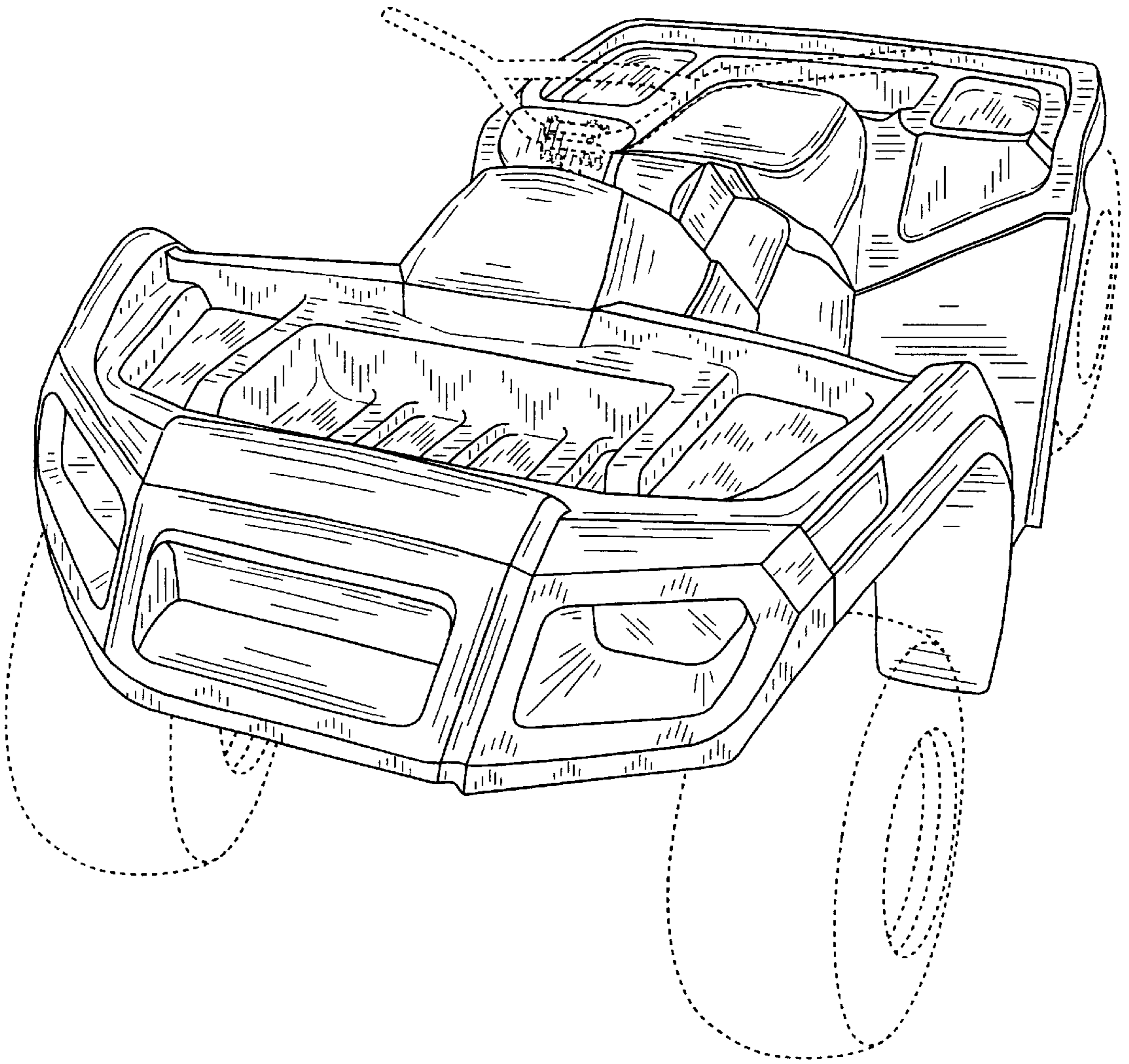

FIG. 1

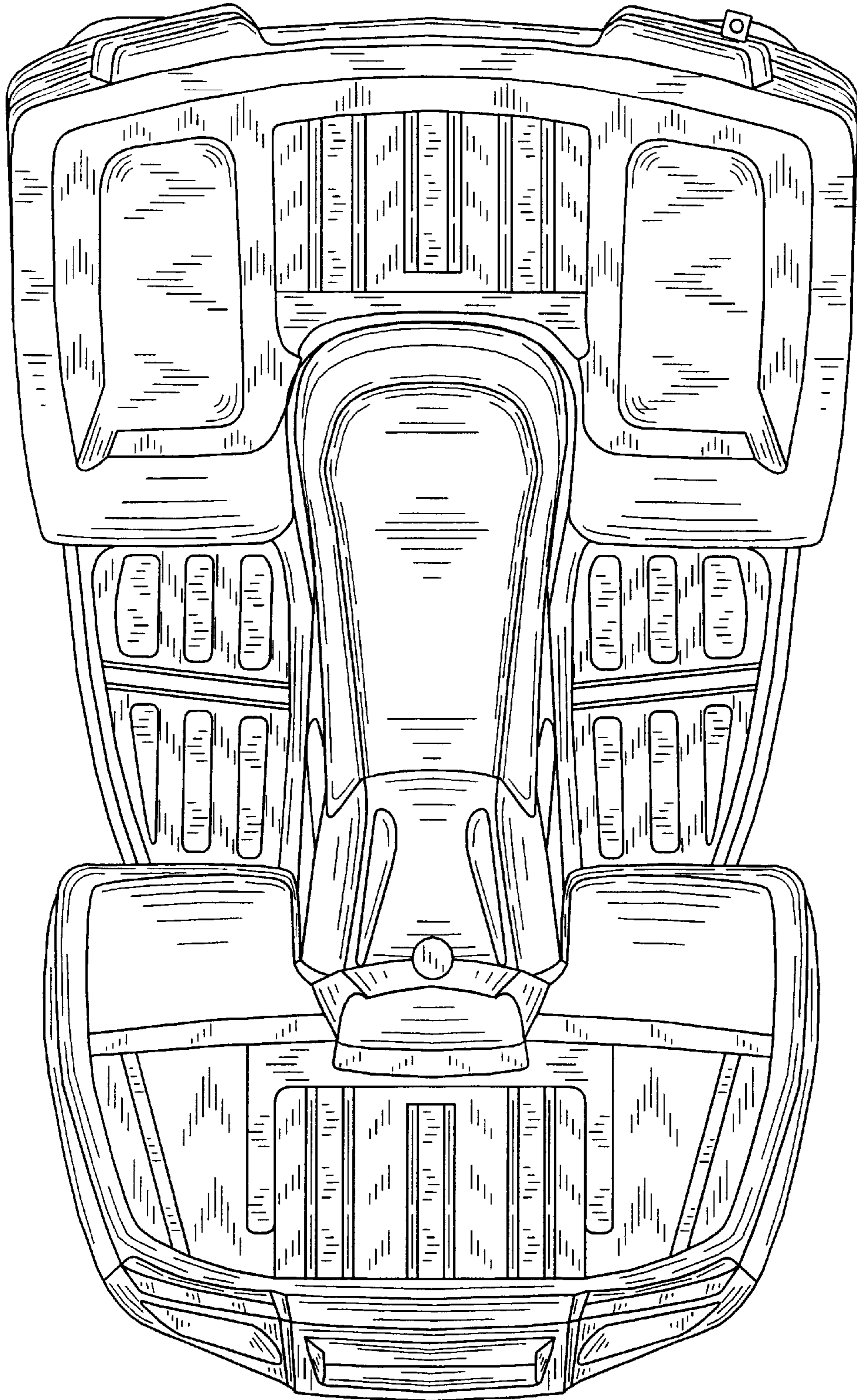

FIG. 2

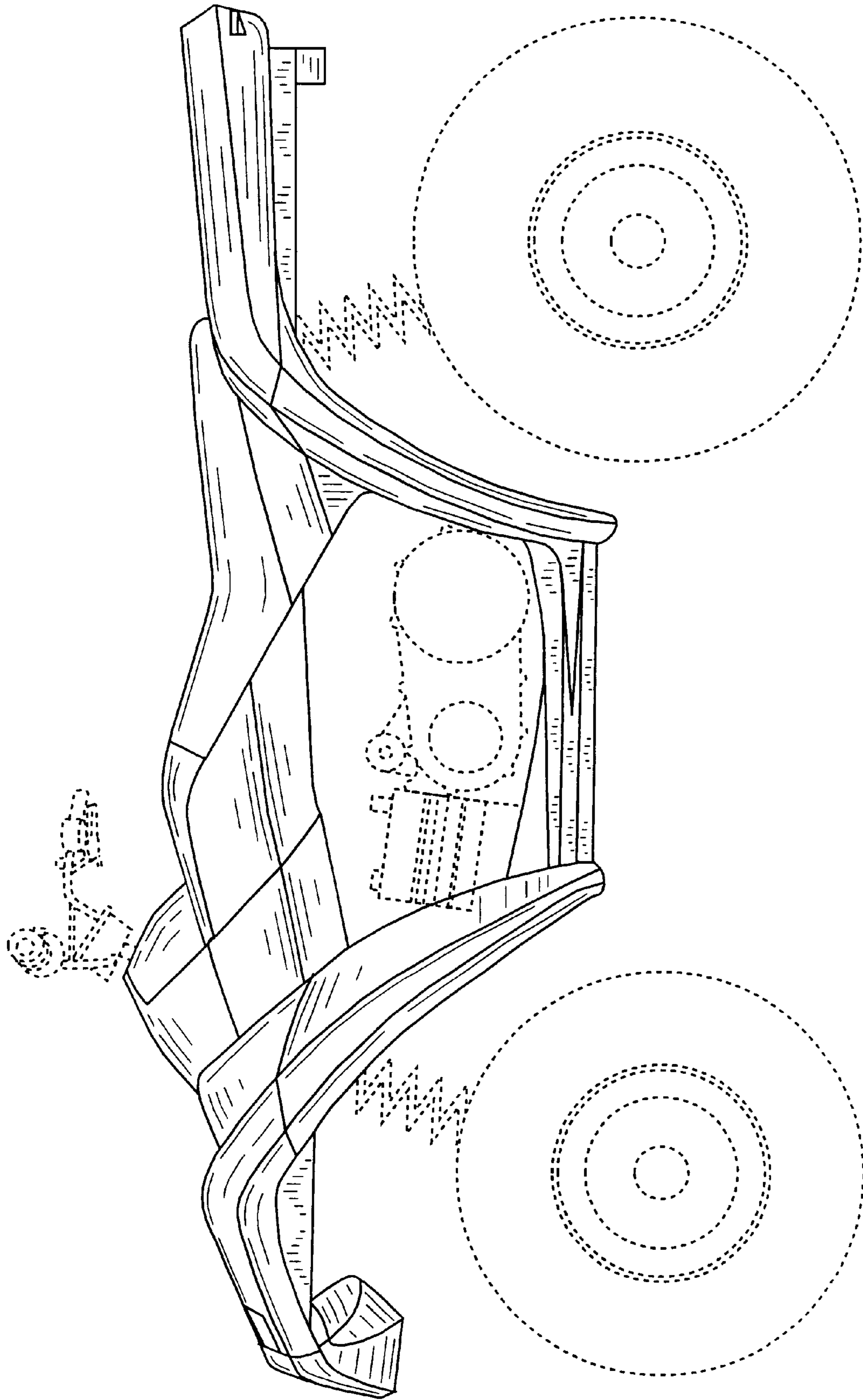

FIG. 3

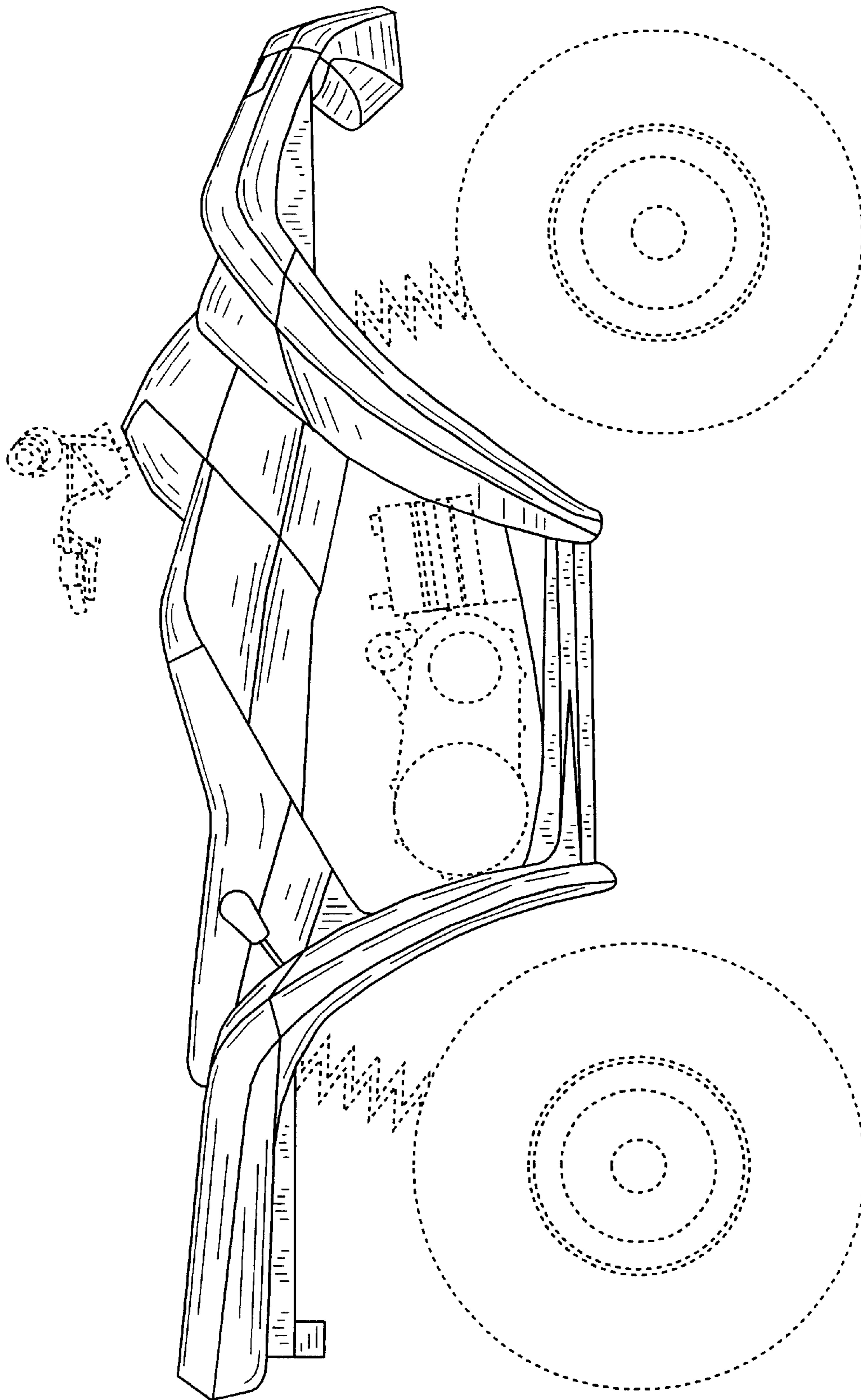

FIG. 4

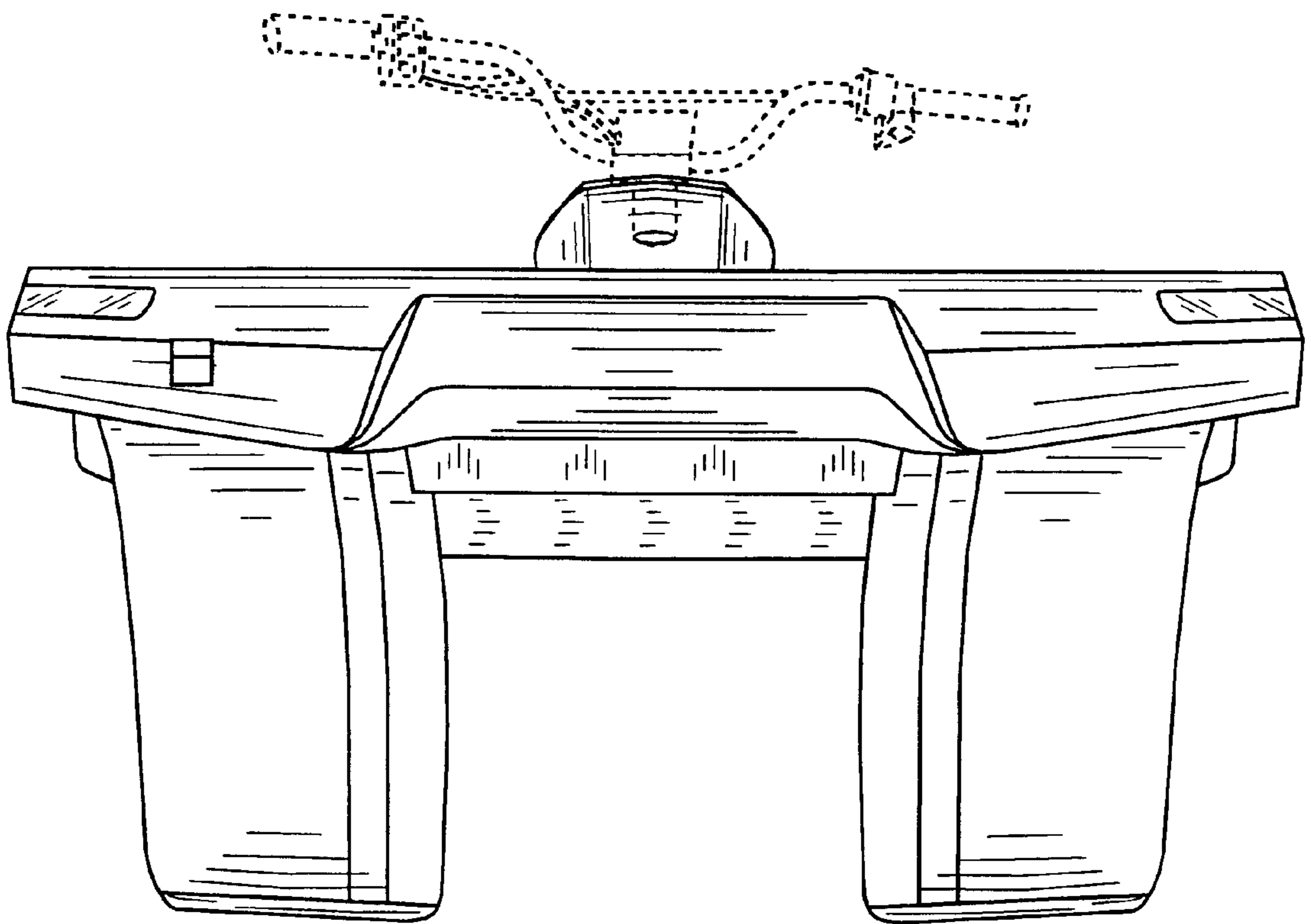

FIG. 5

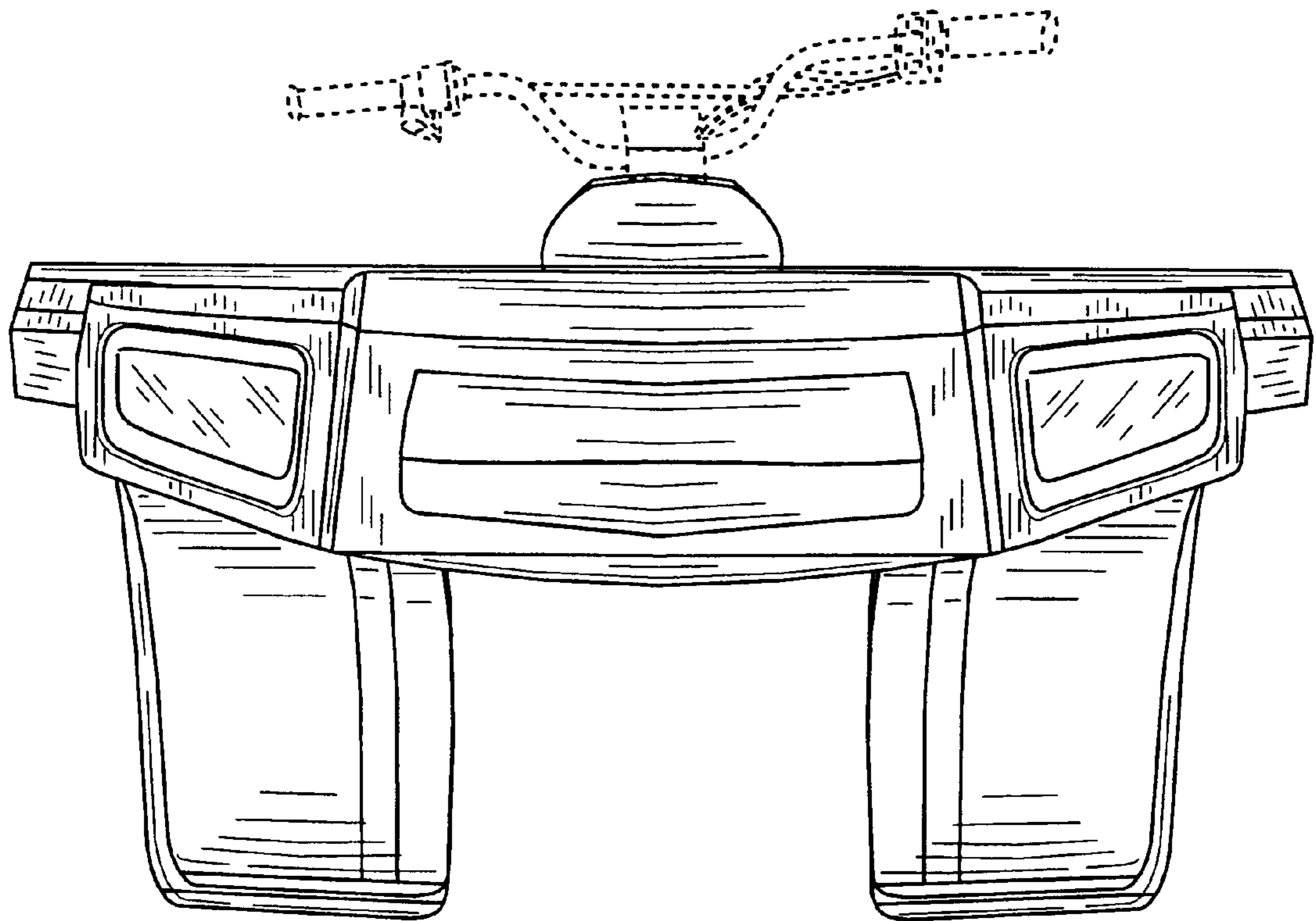

FIG. 6