



US00D472327S

(12) **United States Design Patent**  
**Heath**

(10) **Patent No.:** **US D472,327 S**

(45) **Date of Patent:** **\*\* Mar. 25, 2003**

(54) **FENCE RAIL**

(76) Inventor: **Randall D. Heath**, 3300 Pinson Valley Pkwy., Pinson, AL (US) 35217

(\*\*) Term: **14 Years**

(21) Appl. No.: **29/161,160**

(22) Filed: **May 23, 2002**

(51) **LOC (7) Cl.** ..... **25-02**

(52) **U.S. Cl.** ..... **D25/38**

(58) **Field of Search** ..... D25/38; 256/59, 256/65.01, 65.02, 65.15, 65.16

(56) **References Cited**

**U.S. PATENT DOCUMENTS**

|           |    |   |         |             |       |        |
|-----------|----|---|---------|-------------|-------|--------|
| 5,529,288 | A  | * | 6/1996  | Cheng-I     | ..... | 256/65 |
| 5,853,167 | A  |   | 12/1998 | West et al. |       |        |
| 5,988,599 | A  |   | 11/1999 | Forbis      |       |        |
| 6,041,486 | A  |   | 3/2000  | Forbis      |       |        |
| 6,202,987 | B1 |   | 3/2001  | Forbis      |       |        |
| D446,315  | S  |   | 8/2001  | Forbis      |       |        |

**OTHER PUBLICATIONS**

U.S. Trademark Ser. No. 76/068,883, design only, filed on Jun. 12, 2000, by Kroy Building Products, Inc.

U.S. Trademark Ser. No. 76/279,558, design only, filed on Jul. 3, 2001, by Kroy Building Products, Inc.

\* cited by examiner

*Primary Examiner*—Doris Clark  
(74) *Attorney, Agent, or Firm*—Smith, Gambrell & Russell, LLP

(57) **CLAIM**

I claim the ornamental design for a fence rail, as shown and described.

**DESCRIPTION**

FIG. 1 is a perspective view of the design of the of the fence rail;  
FIG. 2 is a front elevational view of the fence rail taken along lines 2—2 of FIG. 1, this view being a mirror image of the rear elevational view of the fence rail  
FIG. 3 is a top plan view of the fence rail taken along lines 3—3 of FIG. 2;  
FIG. 4 is a bottom view of the fence rail taken along lines 4—4 of FIG. 2; and,  
FIG. 5 is a side elevational view of a first side of the fence rail taken along lines 5—5 of FIG. 2, this view being a mirror image of a side elevational view of a second side of the fence rail.

**1 Claim, 4 Drawing Sheets**

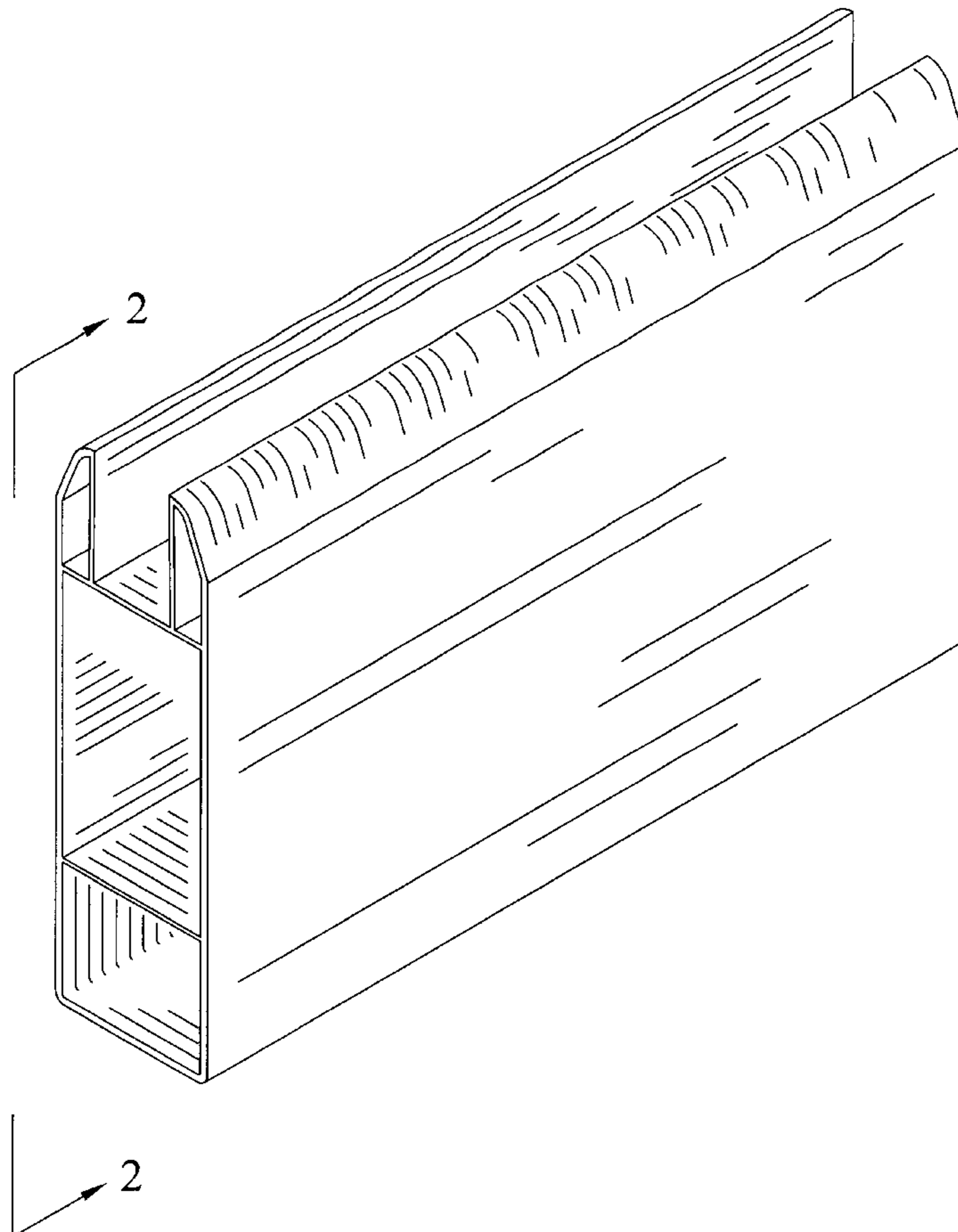

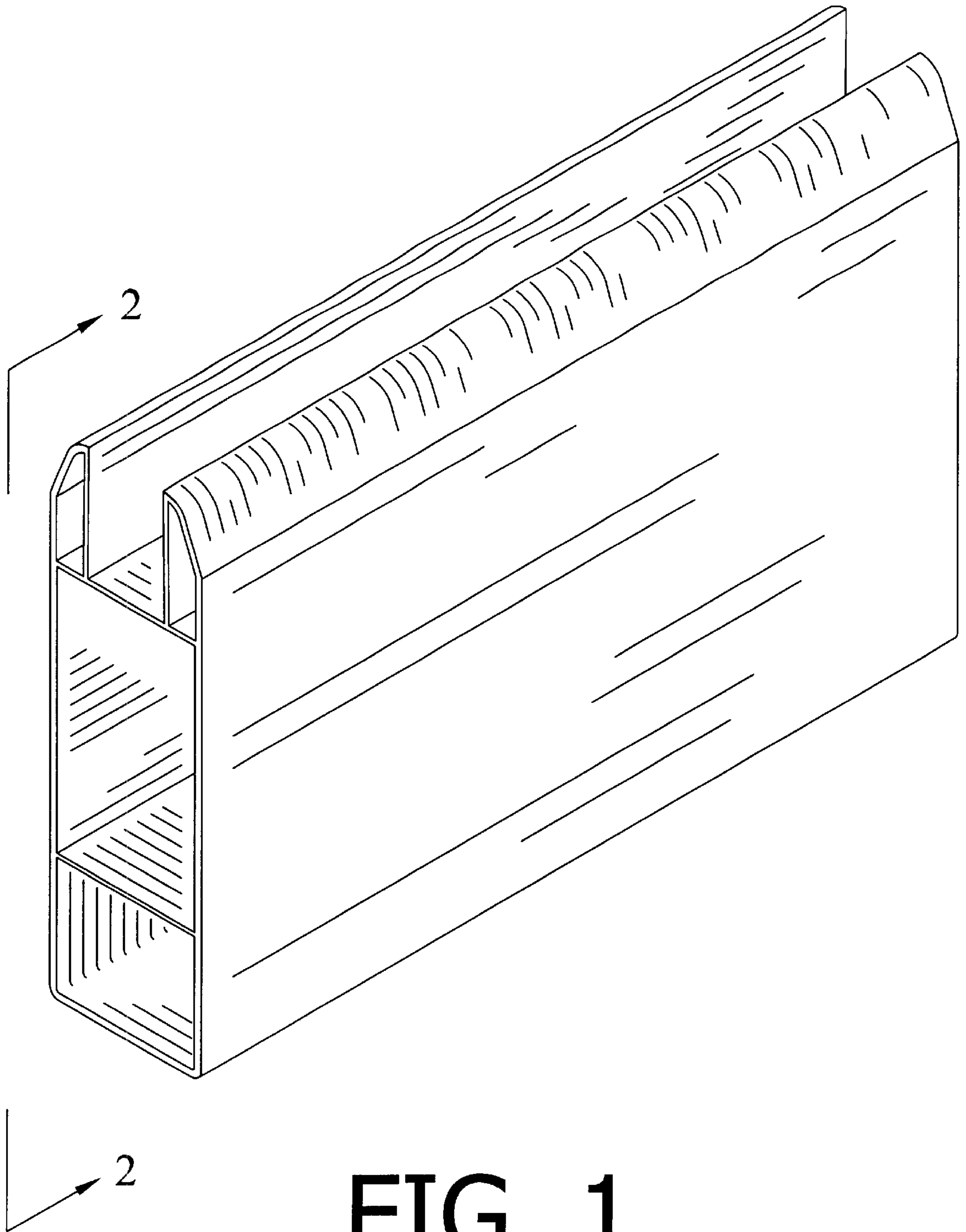

**FIG. 1**

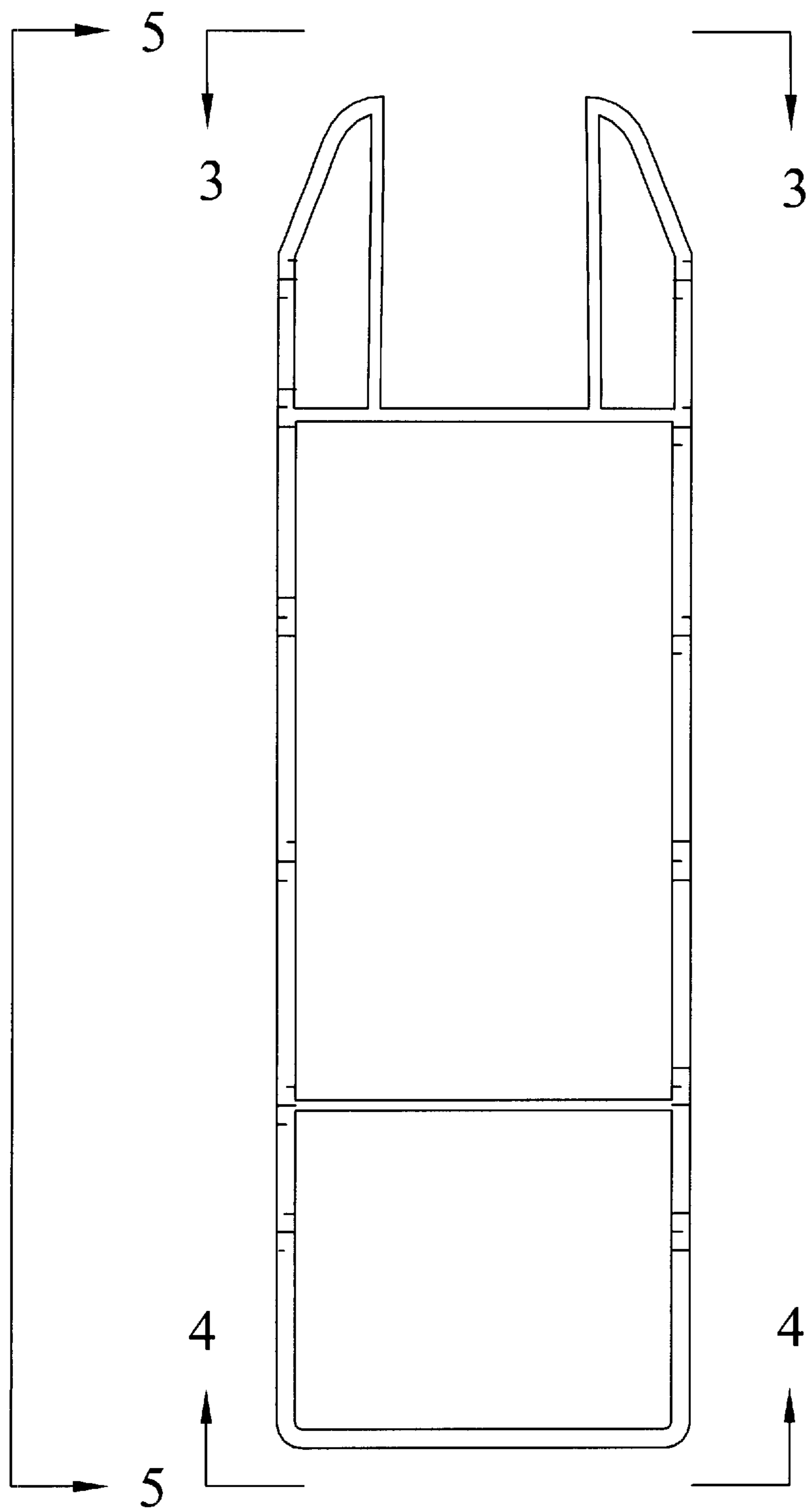
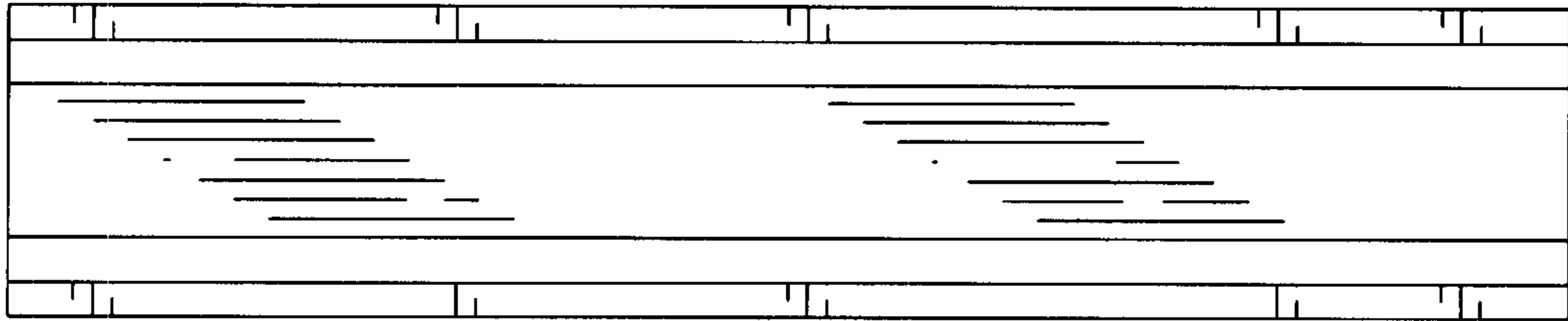
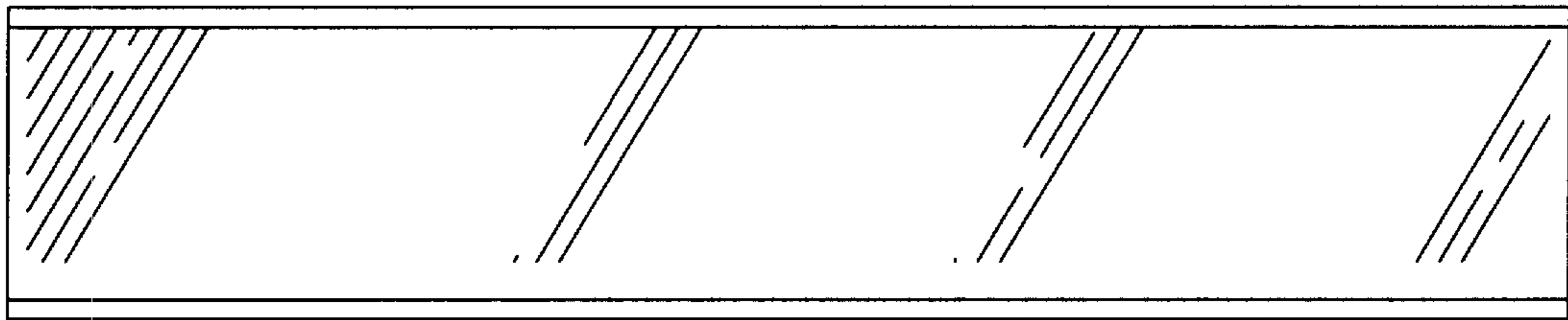

FIG. 2



**FIG. 3**



**FIG. 4**



**FIG. 5**