



US00D471877S

(12) **United States Design Patent**
Dyer et al.

(10) **Patent No.:** **US D471,877 S**

(45) **Date of Patent:** **** Mar. 18, 2003**

(54) **RACEWAY FITTING**

(75) Inventors: **Edward P. Dyer**, Germantown, WI
(US); **Mark E. Federspiel**, West Bend,
WI (US)

(73) Assignee: **HellermannTyton Corporation**,
Milwaukee, WI (US)

(**) Term: **14 Years**

(21) Appl. No.: **29/151,173**

(22) Filed: **Oct. 31, 2001**

(51) **LOC (7) Cl.** **13-03**

(52) **U.S. Cl.** **D13/155**

(58) **Field of Search** D13/155, 156,
D13/173, 184; 52/220.7, 287.1; 138/92,
95, 155, 156; 174/48, 49, 68.3, 72 C, 95,
101

- 5,089,667 A 2/1992 Goussin et al.
- 5,161,580 A 11/1992 Klug
- D331,916 S * 12/1992 DuBrucq D13/155
- 5,184,441 A * 2/1993 Balfanz, Jr. 52/241
- 5,206,972 A 5/1993 Nudelmont et al.
- 5,287,666 A * 2/1994 Frascaroli et al. 52/239
- D348,432 S * 7/1994 DuBruco D13/155
- 5,336,849 A 8/1994 Whitney
- 5,359,143 A 10/1994 Simon
- 5,399,812 A 3/1995 Woscynna et al.
- D371,343 S * 7/1996 Loftus D13/155
- D378,731 S * 4/1997 Kopish D13/155
- 5,682,926 A * 11/1997 Perttula 138/157
- 5,792,992 A 8/1998 Handler
- 5,802,672 A 9/1998 Rohder
- D401,224 S * 11/1998 Mollenkopf et al. D13/155
- D402,262 S * 12/1998 Scherer et al. D13/155
- D402,263 S * 12/1998 Scherer et al. D13/155
- D402,264 S * 12/1998 Carlson et al. D13/155
- 5,861,576 A 1/1999 Langston et al.

(List continued on next page.)

(56) **References Cited**

U.S. PATENT DOCUMENTS

- 2,317,964 A * 4/1943 O'Brien 174/101
- 2,440,668 A 4/1948 Tarbox
- 3,403,220 A 9/1968 Riedel et al.
- 3,546,360 A 12/1970 Bailey
- 3,554,236 A 1/1971 Rhodes
- 3,761,603 A 9/1973 Hays et al.
- 3,763,401 A 10/1973 Ransom
- 3,786,171 A 1/1974 Shira
- 3,890,459 A 6/1975 Caveney
- 3,906,146 A 9/1975 Taylor
- 4,166,195 A 8/1979 Schwab
- 4,391,426 A 7/1983 Gothberg
- 4,530,865 A 7/1985 Sprenger
- 4,602,124 A 7/1986 Santucci
- 4,627,469 A 12/1986 Buard
- 4,627,679 A 12/1986 Billette de Villemeur et al.
- 4,629,826 A 12/1986 Thomas
- 4,640,314 A 2/1987 Mock
- 4,879,955 A * 11/1989 Moll et al. 108/50.02
- 4,907,767 A 3/1990 Corsi et al.
- 4,952,163 A 8/1990 Dola et al.
- 5,086,195 A 2/1992 Claisse

Primary Examiner—Robert M. Spear

(74) *Attorney, Agent, or Firm*—Ryan Kromholz & Manion,
S.C.

(57) **CLAIM**

The ornamental design for a raceway fitting, as shown and described.

DESCRIPTION

FIG. 1 is a perspective view of a raceway fitting showing our new design;

FIG. 2 is an enlarged end view thereof, the opposite end view being identical;

FIG. 3 is a side view thereof, the opposite side view being identical;

FIG. 4 is a top plan view thereof; and,

FIG. 5 is an exploded perspective view thereof.

The broken line showing in the Figures is for illustrative purposes only and forms no part of the claimed design.

1 Claim, 2 Drawing Sheets

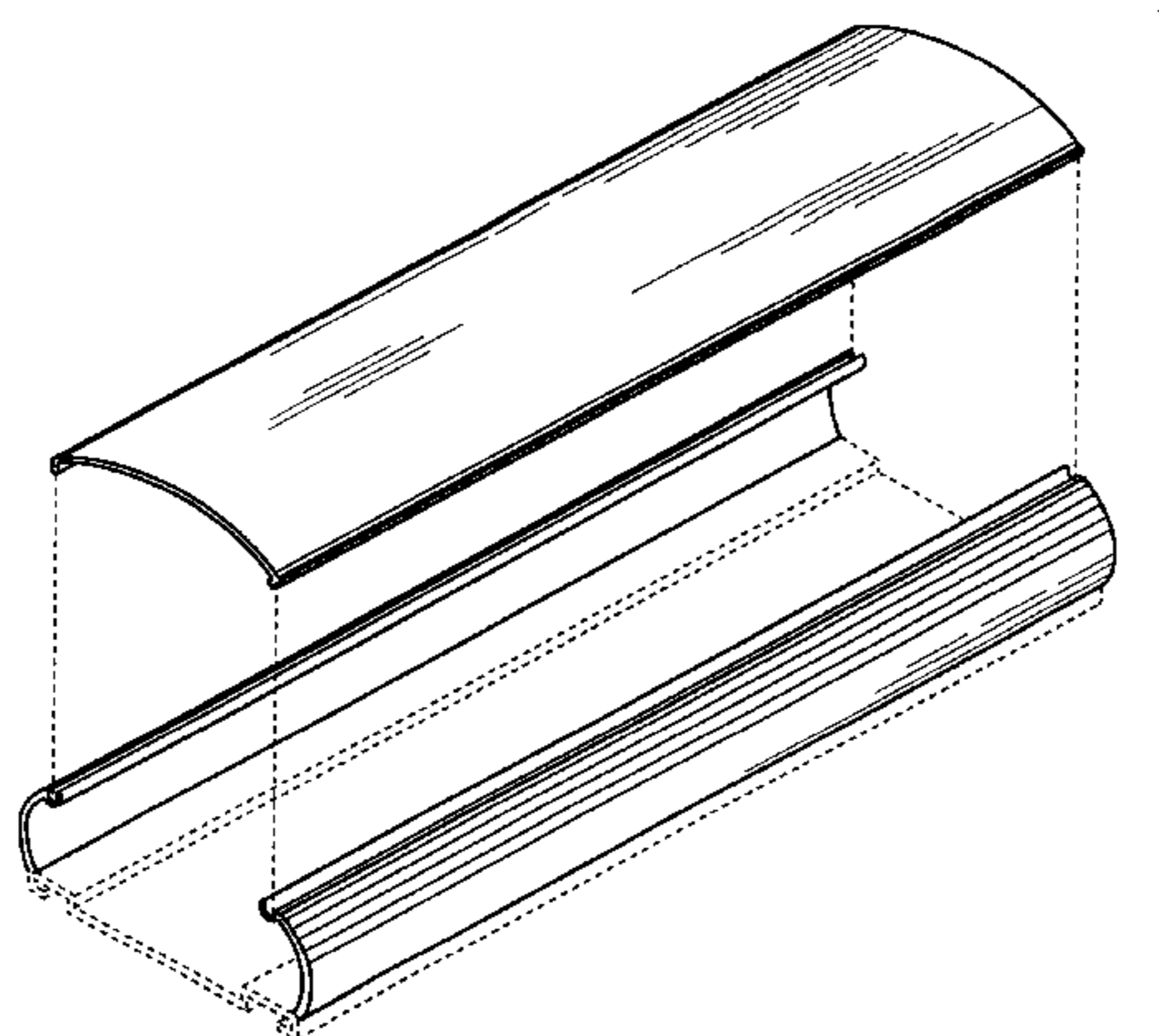

US D471,877 S

Page 2

U.S. PATENT DOCUMENTS					
5,998,732 A	12/1999	Caveney et al.	6,107,575 A	8/2000	Miranda
6,188,024 B1	2/2000	Benito-Navazo	6,107,576 A	8/2000	Morton et al.
6,037,543 A	3/2000	Nicoli et al.	D430,543 S *	9/2000	Rohder D13/155
6,084,180 A	7/2000	DeBartolo, Jr. et al.	6,180,878 B1	1/2001	Gretz
D429,225 S *	8/2000	Halliday D13/184	6,211,460 B1	4/2001	Hull et al.
					* cited by examiner

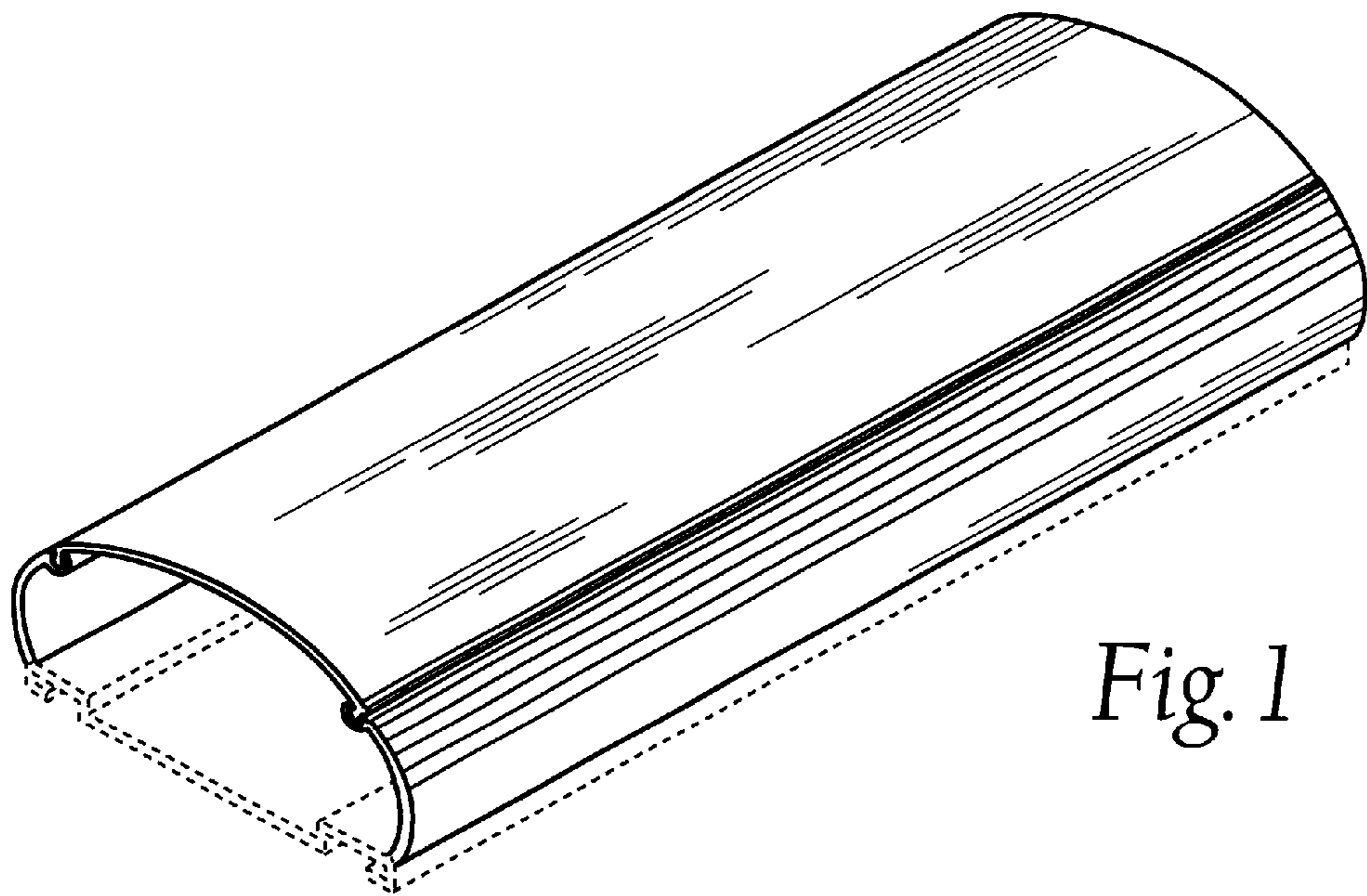

Fig. 1

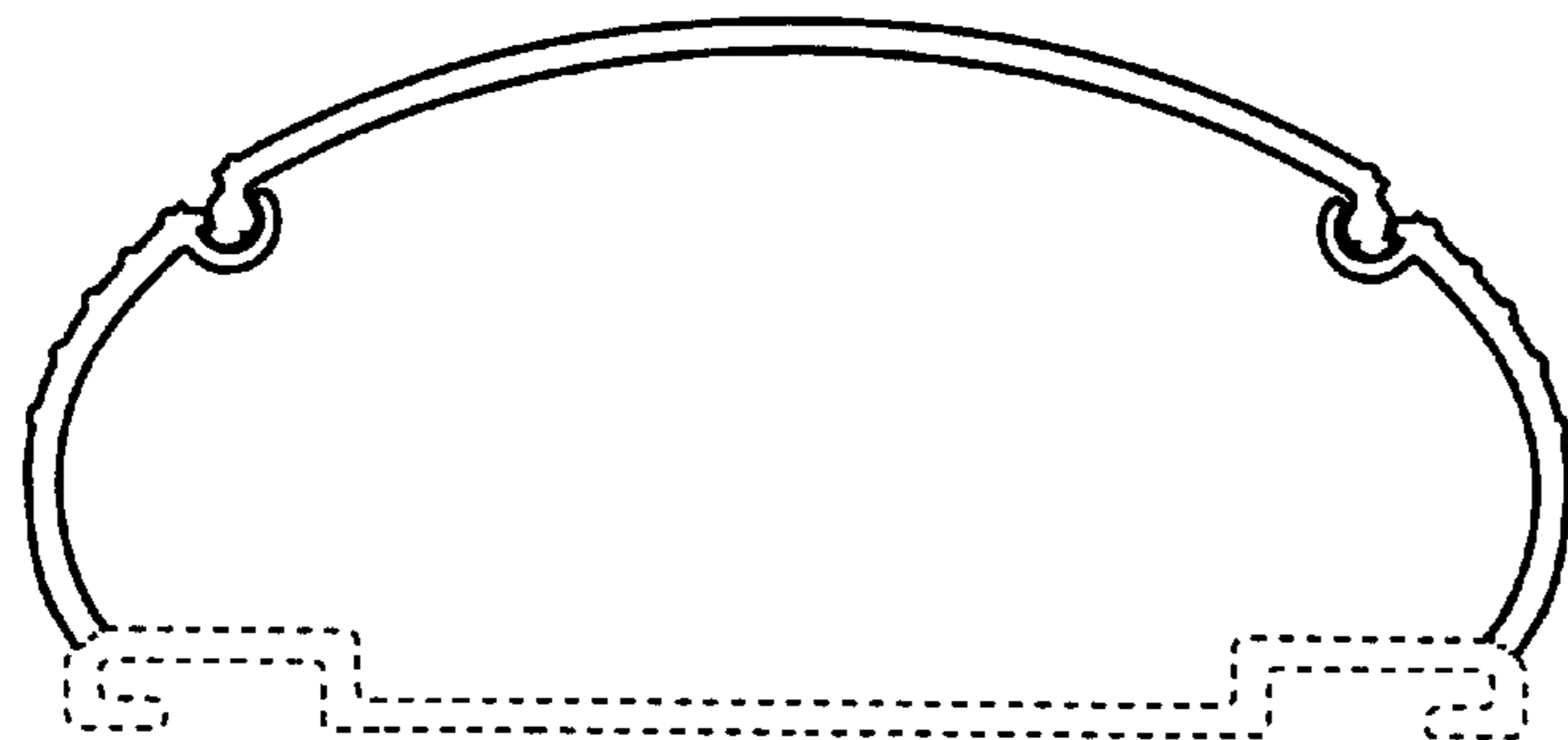

Fig. 2

Fig. 3

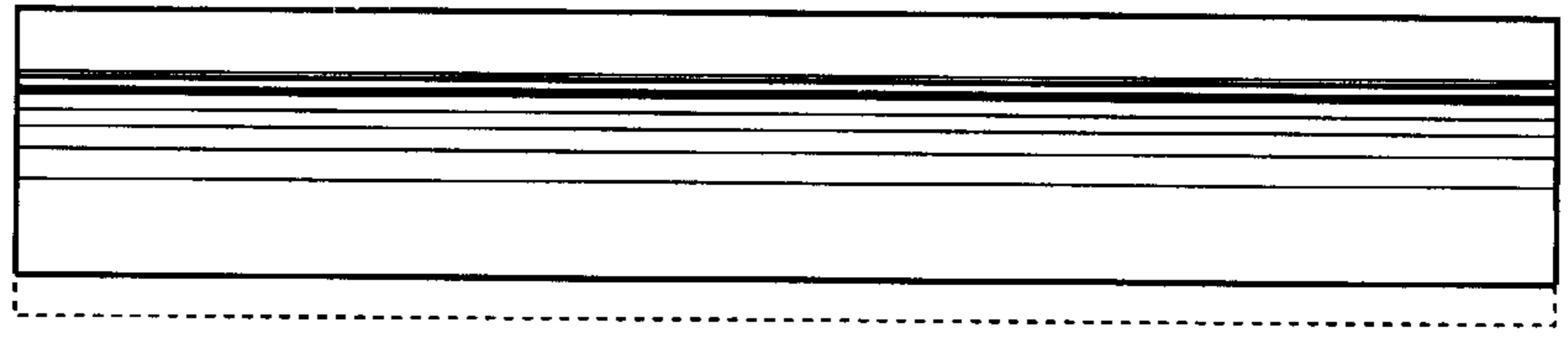

Fig. 4

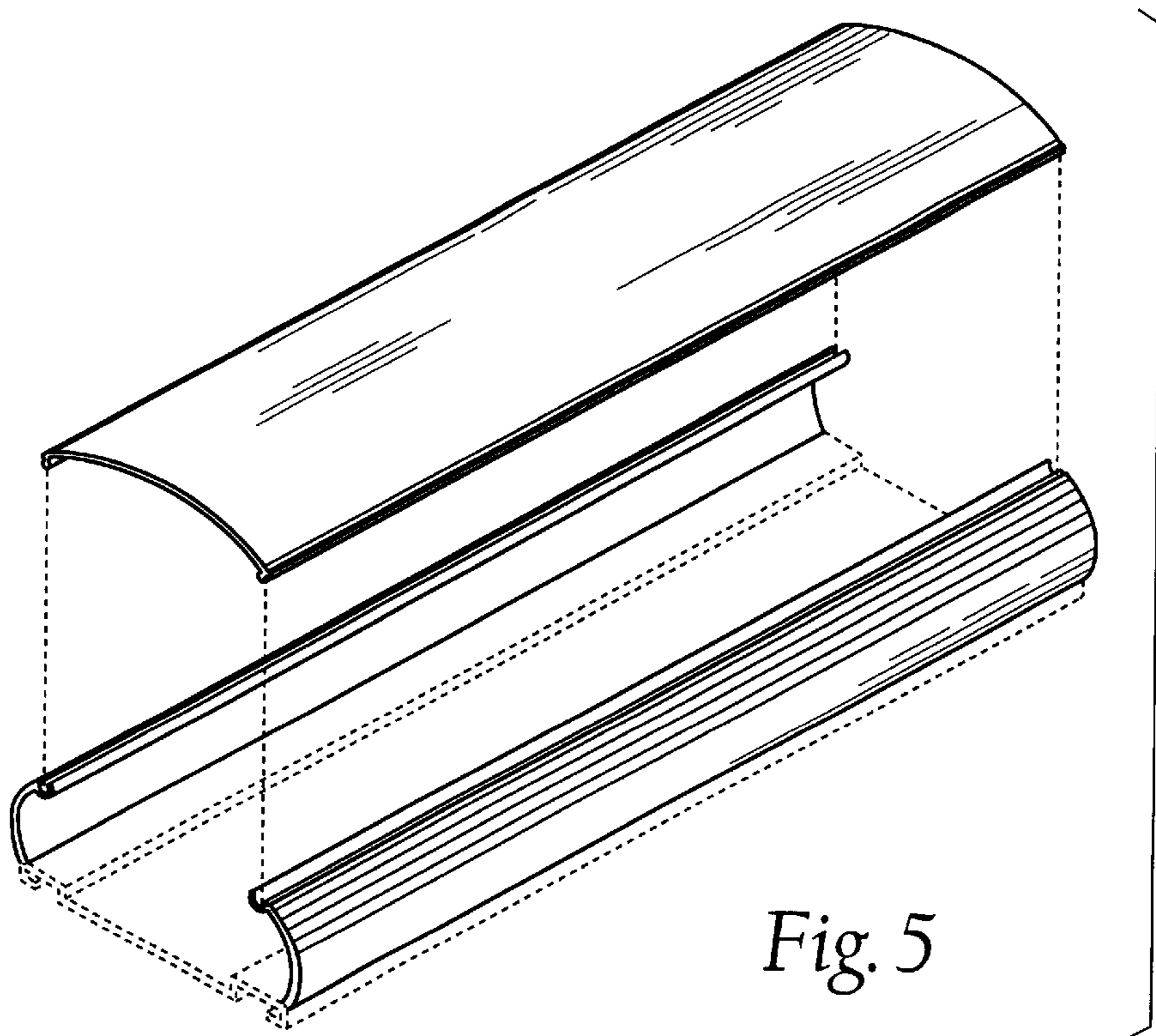
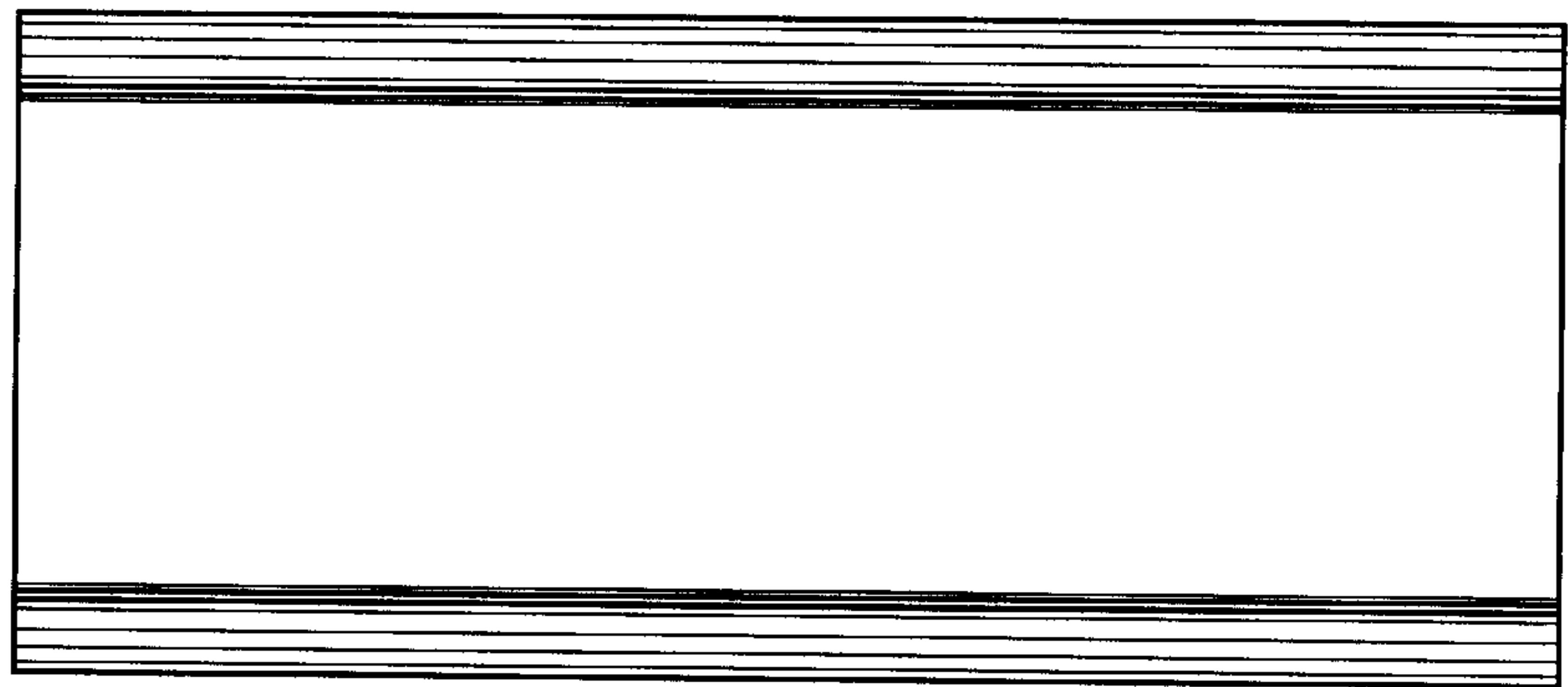

Fig. 5