



US00D471843S

(12) **United States Design Patent**  
**Hall**

(10) **Patent No.:** **US D471,843 S**

(45) **Date of Patent:** **\*\* Mar. 18, 2003**

(54) **ORNAMENTAL TOP FOR GOLF CART**

(76) Inventor: **Timothy P. Hall**, 3108 S. Grant St.,  
Englewood, CO (US) 80110

(\*\*) Term: **14 Years**

(21) Appl. No.: **29/146,891**

(22) Filed: **Aug. 17, 2001**

(51) **LOC (7) Cl.** ..... **12-02**

(52) **U.S. Cl.** ..... **D12/16**

(58) **Field of Search** ..... D12/1, 16, 83;  
D21/533, 548, 560; 180/89.1, 89.4, 908;  
280/DIG. 5; 296/21, 24.1, 102, 225, 177

(56) **References Cited**

**U.S. PATENT DOCUMENTS**

D231,523 S	*	4/1974	Baker	.....	D12/83
D231,911 S	*	6/1974	Baker	.....	D12/83
D252,692 S	*	8/1979	Petrisco	.....	D21/560
D275,583 S	*	9/1984	Murakami	.....	D21/560
D276,172 S	*	10/1984	Murakami	.....	D21/560
D276,249 S	*	11/1984	Murakami	.....	D21/560
D276,357 S	*	11/1984	Murakami	.....	D21/560
D276,358 S	*	11/1984	Murakami	.....	D21/560
D276,595 S	*	12/1984	Miller	.....	D9/434
D282,970 S	*	3/1986	Parkin	.....	D25/16
D300,617 S	*	4/1989	Baker	.....	D12/83
D327,376 S	*	6/1992	Piccamiglio	.....	D6/358
D351,873 S	*	10/1994	Jones, Jr. et al.	.....	D21/533

\* cited by examiner

*Primary Examiner*—Nelson C. Holtje

(74) *Attorney, Agent, or Firm*—Sheridan Ross P.C.

(57) **CLAIM**

The ornamental design for an ornamental top for golf cart, as shown and described.

**DESCRIPTION**

FIG. 1 is a front elevation view of a golf cart top, showing my new design in a first embodiment;  
FIG. 2 is a left elevation view of the invention illustrated in FIG. 1, a right side view not shown, but being symmetrical and identical to the left elevation view;

FIG. 3 is a rear elevation view of the invention illustrated in FIG. 1;

FIG. 4 is a top plan view of the invention illustrated in FIG. 1;

FIG. 5 is a front elevation view of a golf cart top, showing my new design in a second embodiment;

FIG. 6 is a left elevation view of the invention illustrated in FIG. 5, a right side view not shown, but being symmetrical and identical to the left elevation view;

FIG. 7 is a rear elevation view of the invention illustrated in FIG. 5;

FIG. 8 is a top plan view of the invention illustrated in FIG. 5;

FIG. 9 is a front elevation view of a golf cart top, showing my new design in a third embodiment;

FIG. 10 is a left elevation view of the invention illustrated in FIG. 9;

FIG. 11 is a right elevation view of the invention illustrated in FIG. 9;

FIG. 12 is a rear elevation view of the invention illustrated in FIG. 9;

FIG. 13 is a top plan view of the invention illustrated in FIG. 9;

FIG. 14 is a front elevation view of a golf cart top, showing my new design in a fourth embodiment;

FIG. 15 is a left elevation view of the invention illustrated in FIG. 14, a right side view not shown, but being symmetrical and identical to the left elevation view;

FIG. 16 is a rear elevation view of the invention illustrated in FIG. 14;

FIG. 17 is a top plan view of the invention illustrated in FIG. 14;

FIG. 18 is a front elevation view of a golf cart top, showing my new design in a fifth embodiment;

FIG. 19 is a left elevation view of the invention illustrated in FIG. 18, a right side view not shown, but being symmetrical and identical to the left elevation view;

FIG. 20 is rear elevation view of the invention illustrated in FIG. 18; and,

FIG. 21 is a top plan view of the invention illustrated in FIG. 18.

The broken line showings of a golf cart and top support are for illustrative purposes only and forms no part of the claimed design.

**1 Claim, 5 Drawing Sheets**

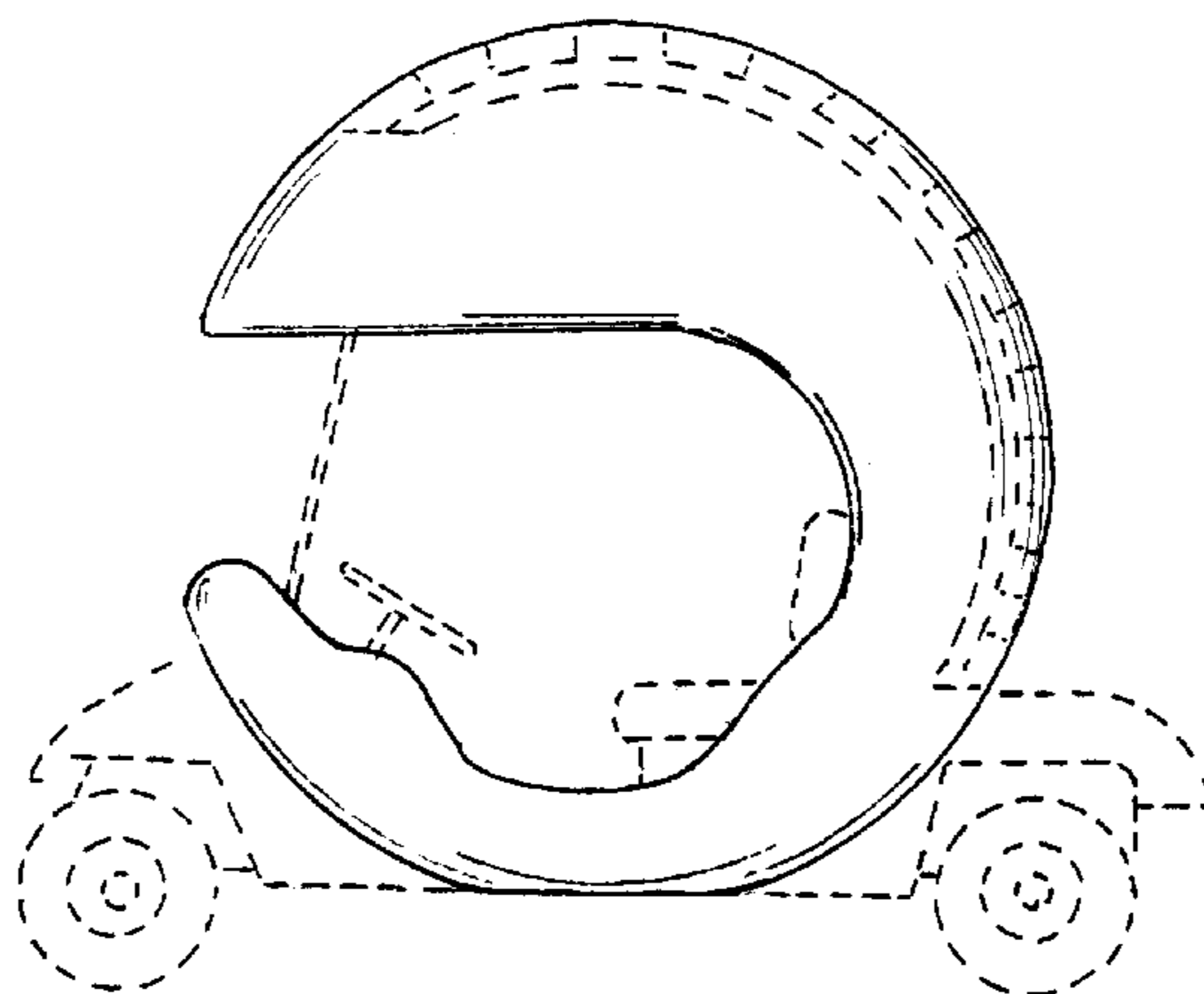

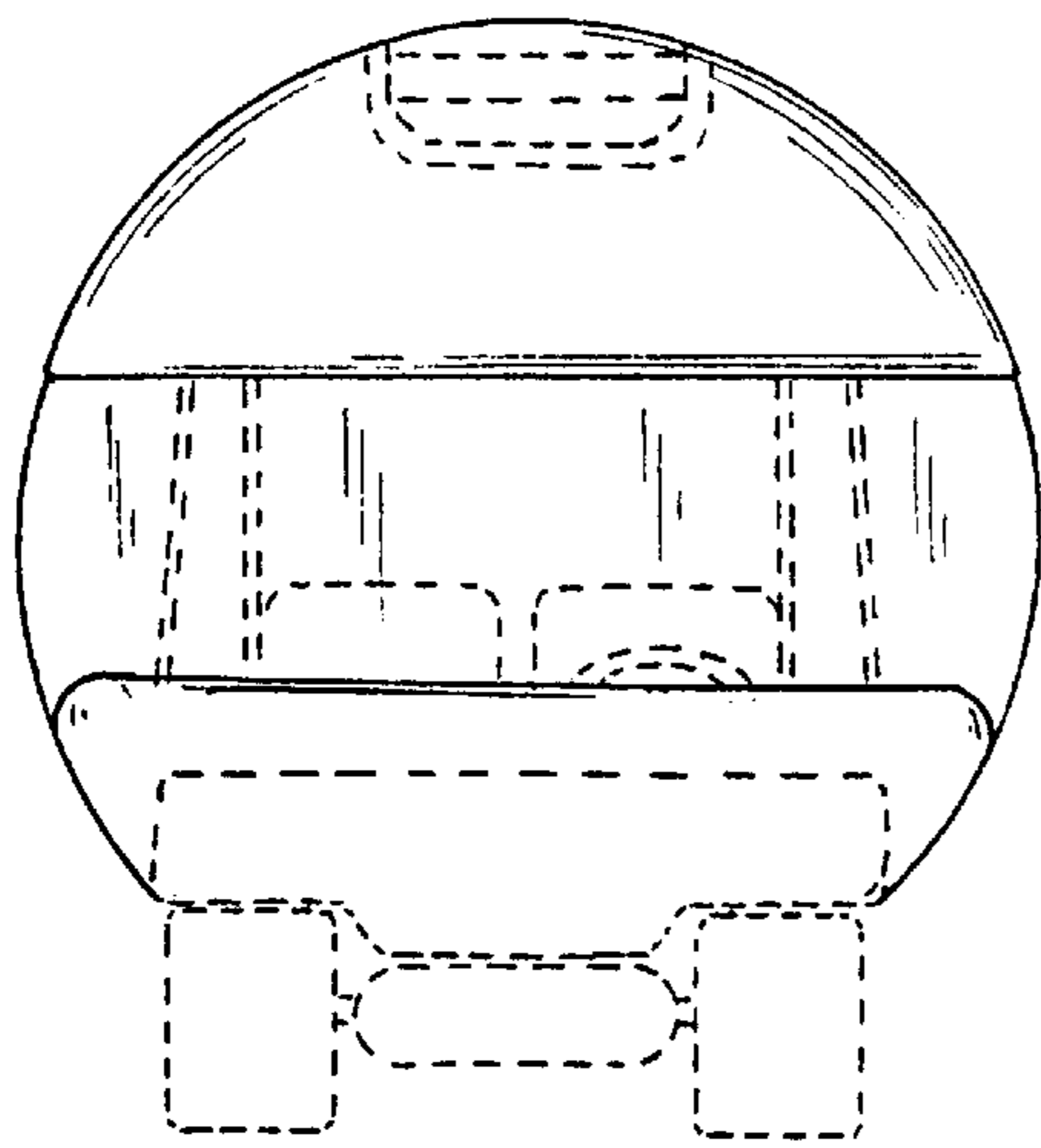

*Fig\_1*

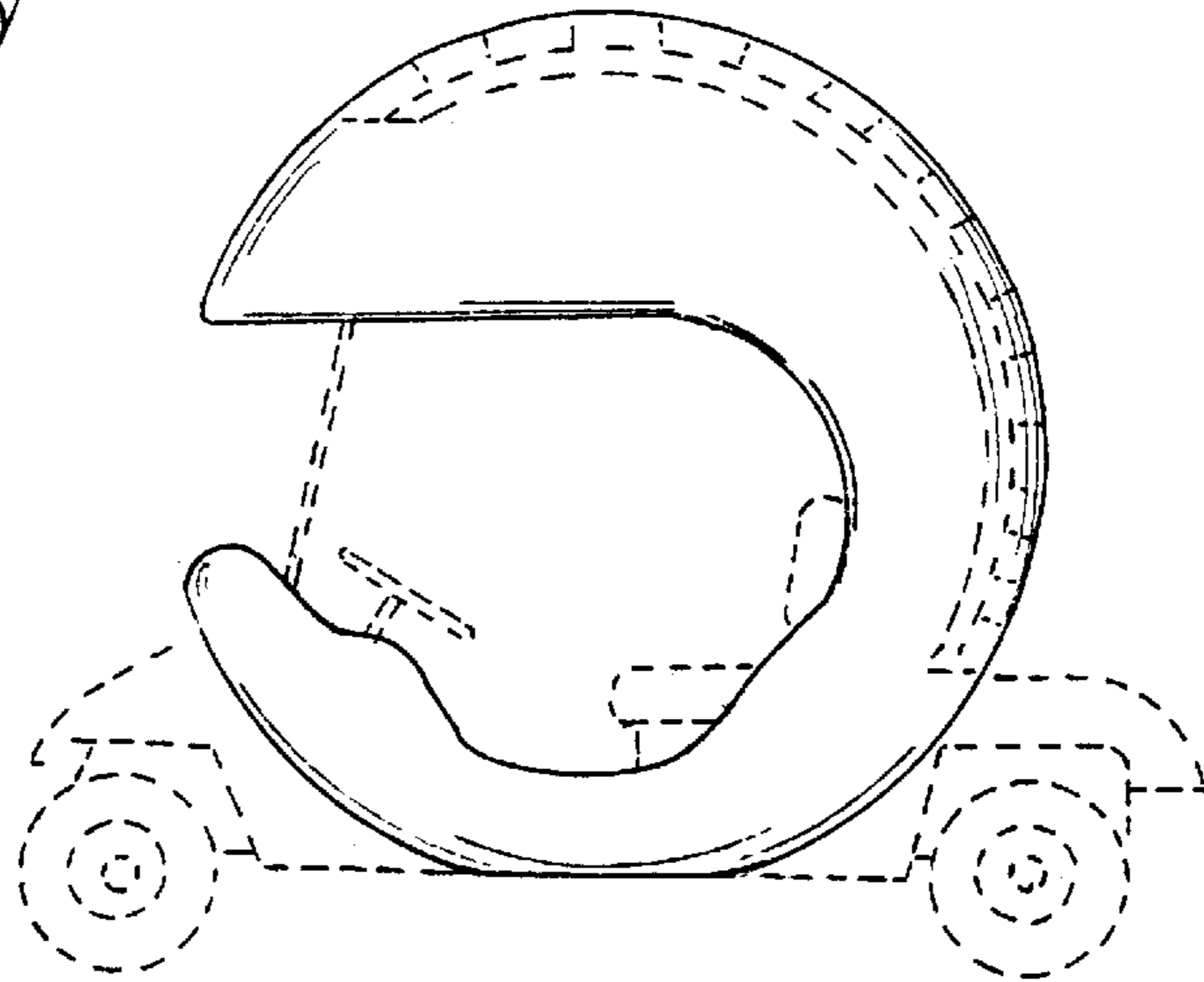

*Fig\_2*

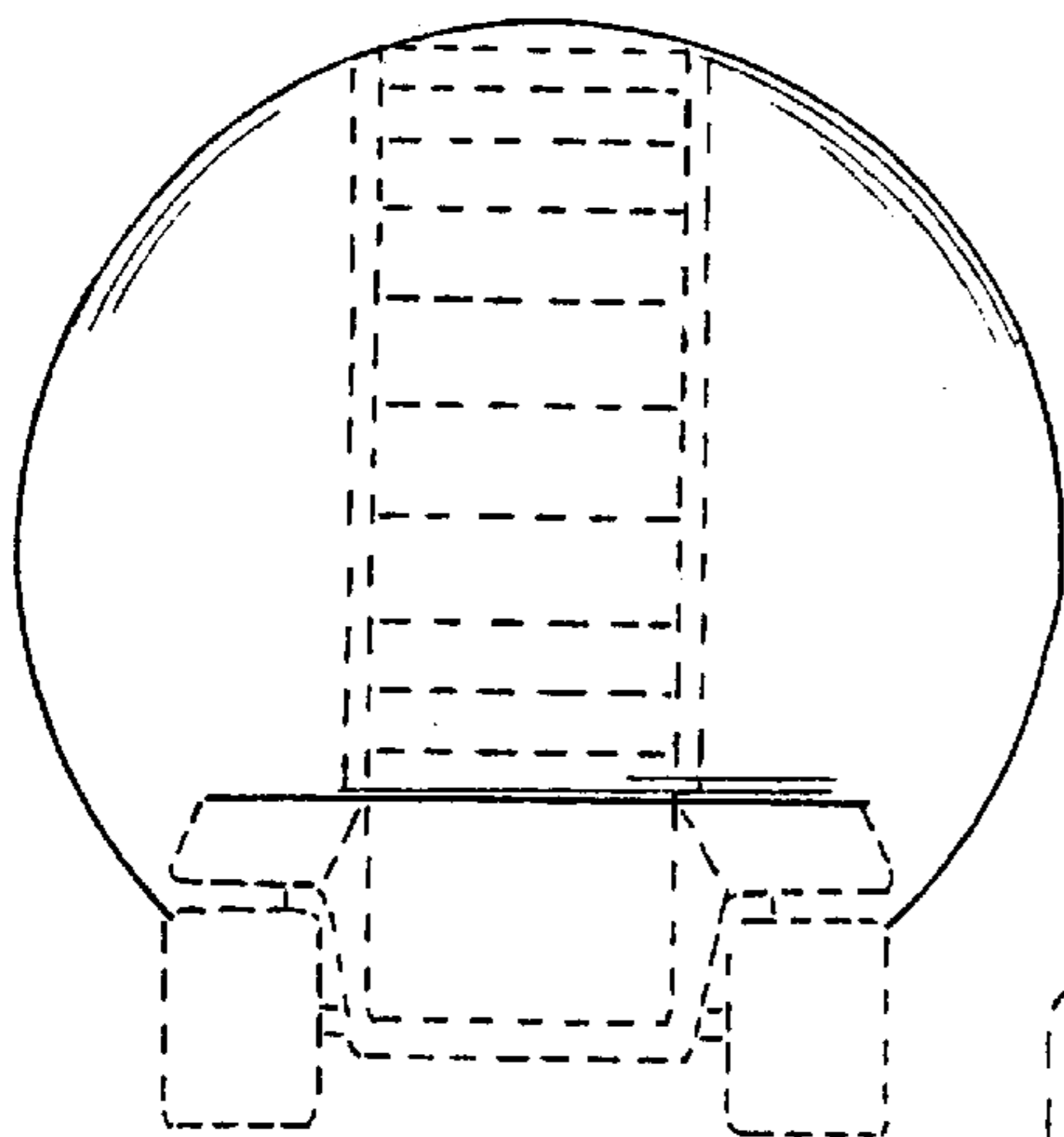

*Fig\_3*

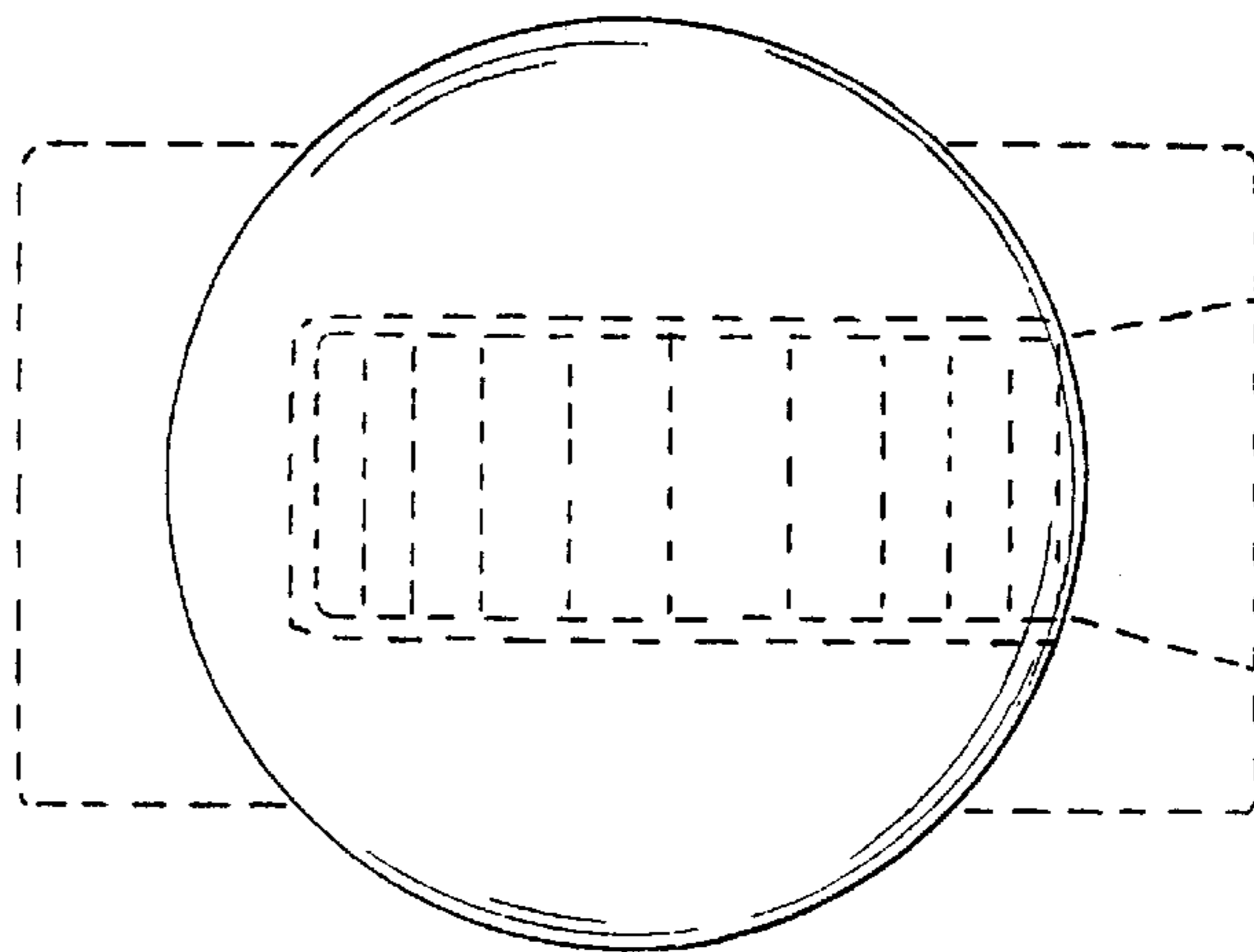

*Fig\_4*

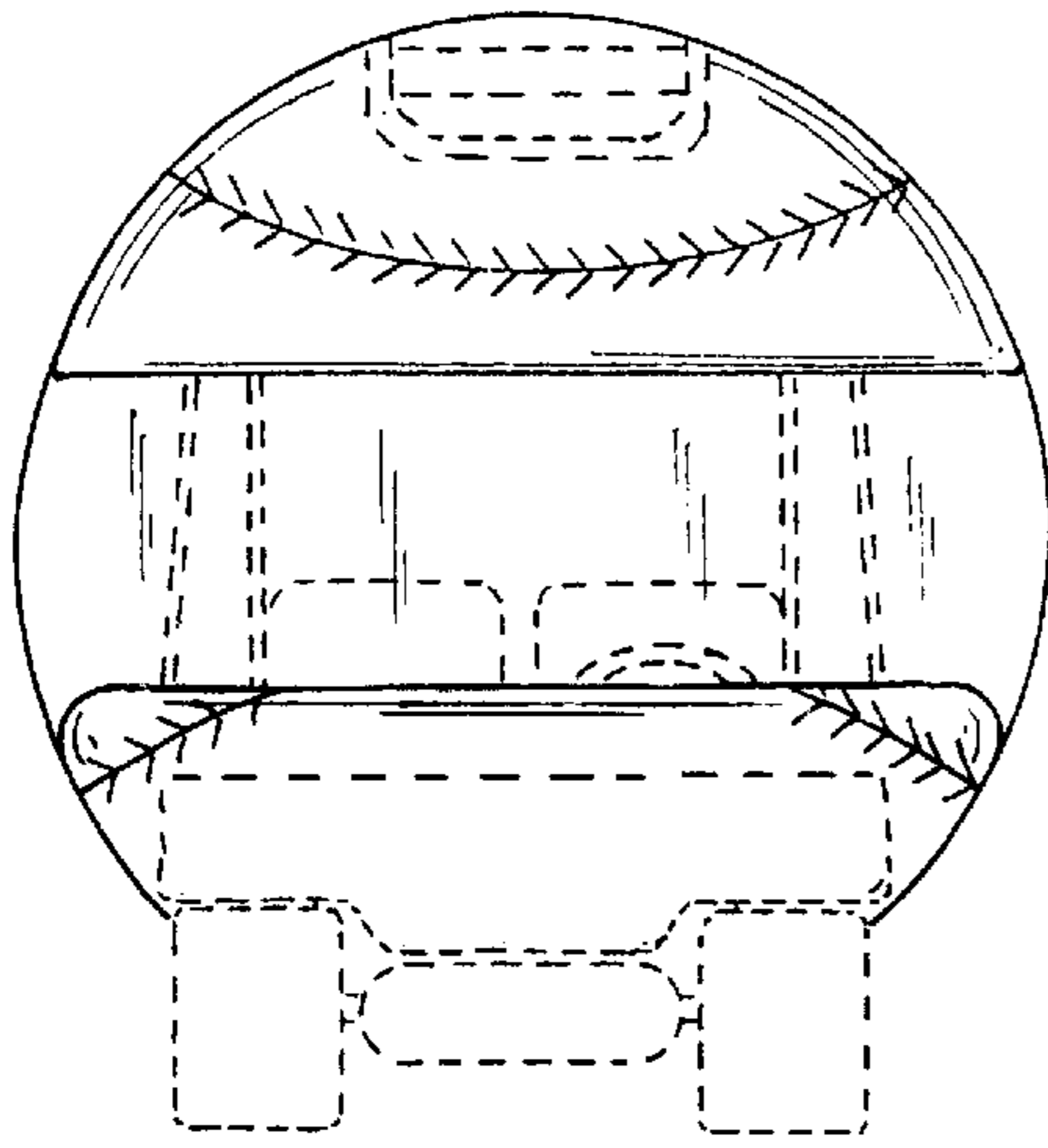

*Fig\_5*

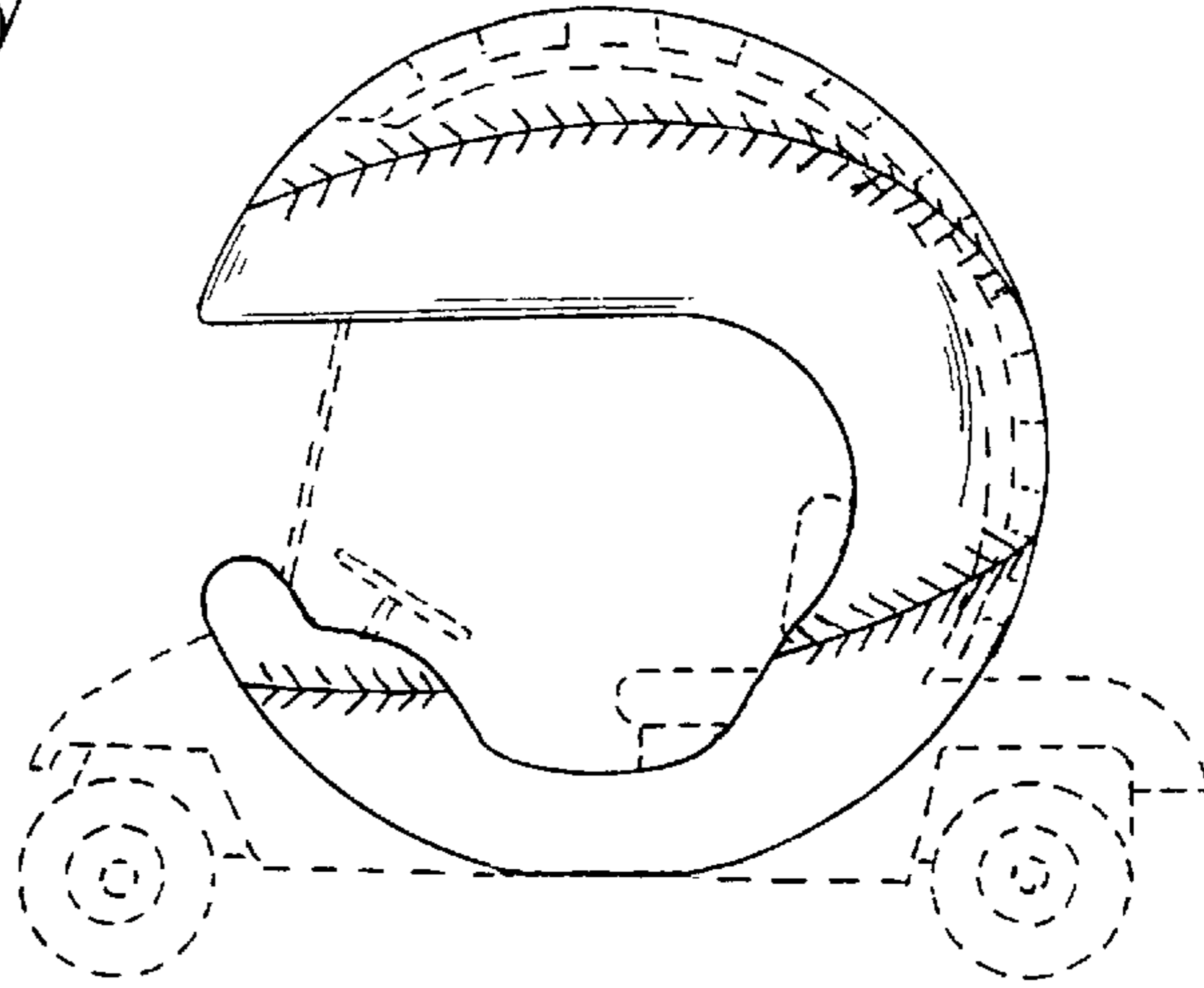

*Fig\_6*

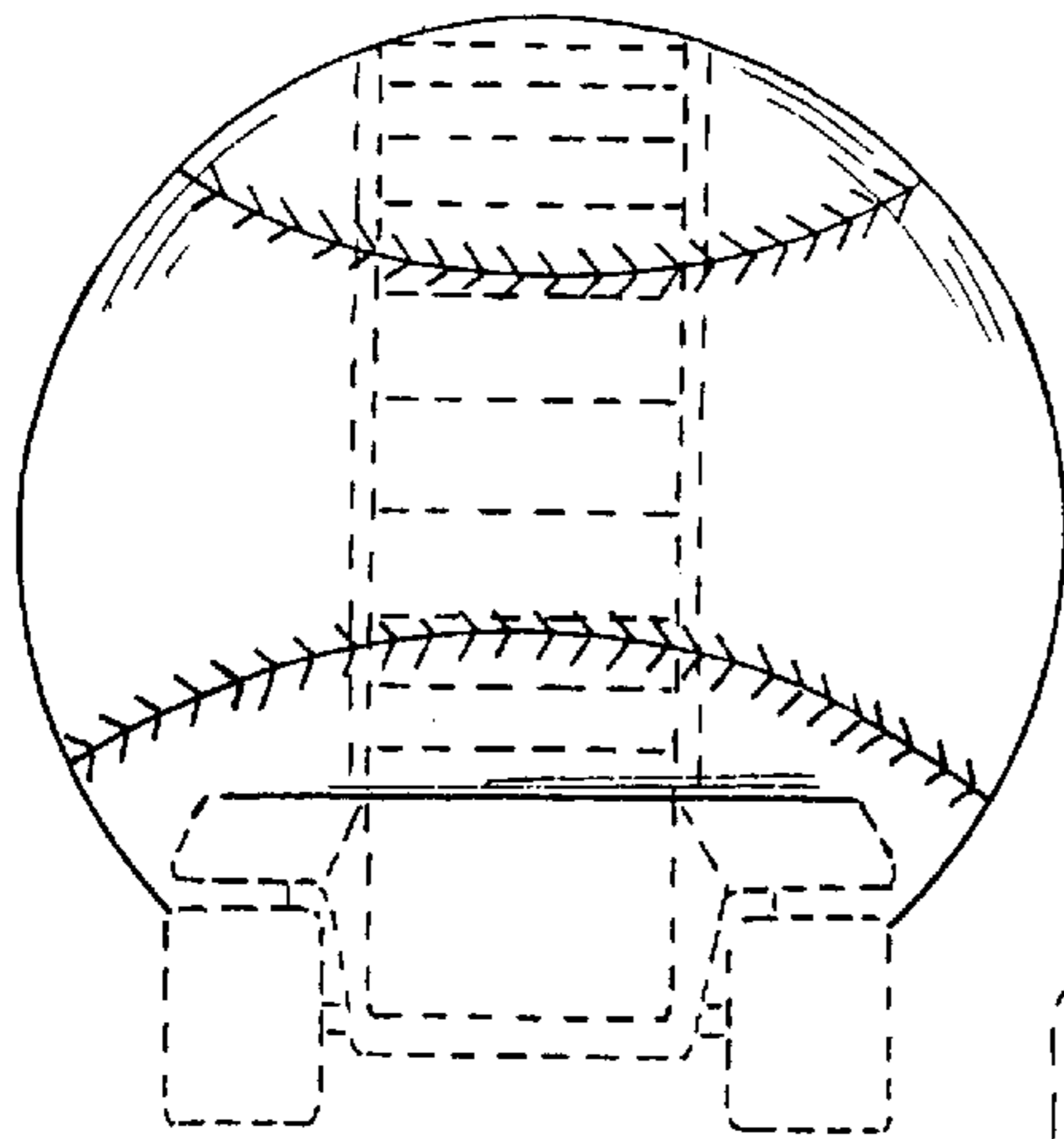

*Fig\_7*

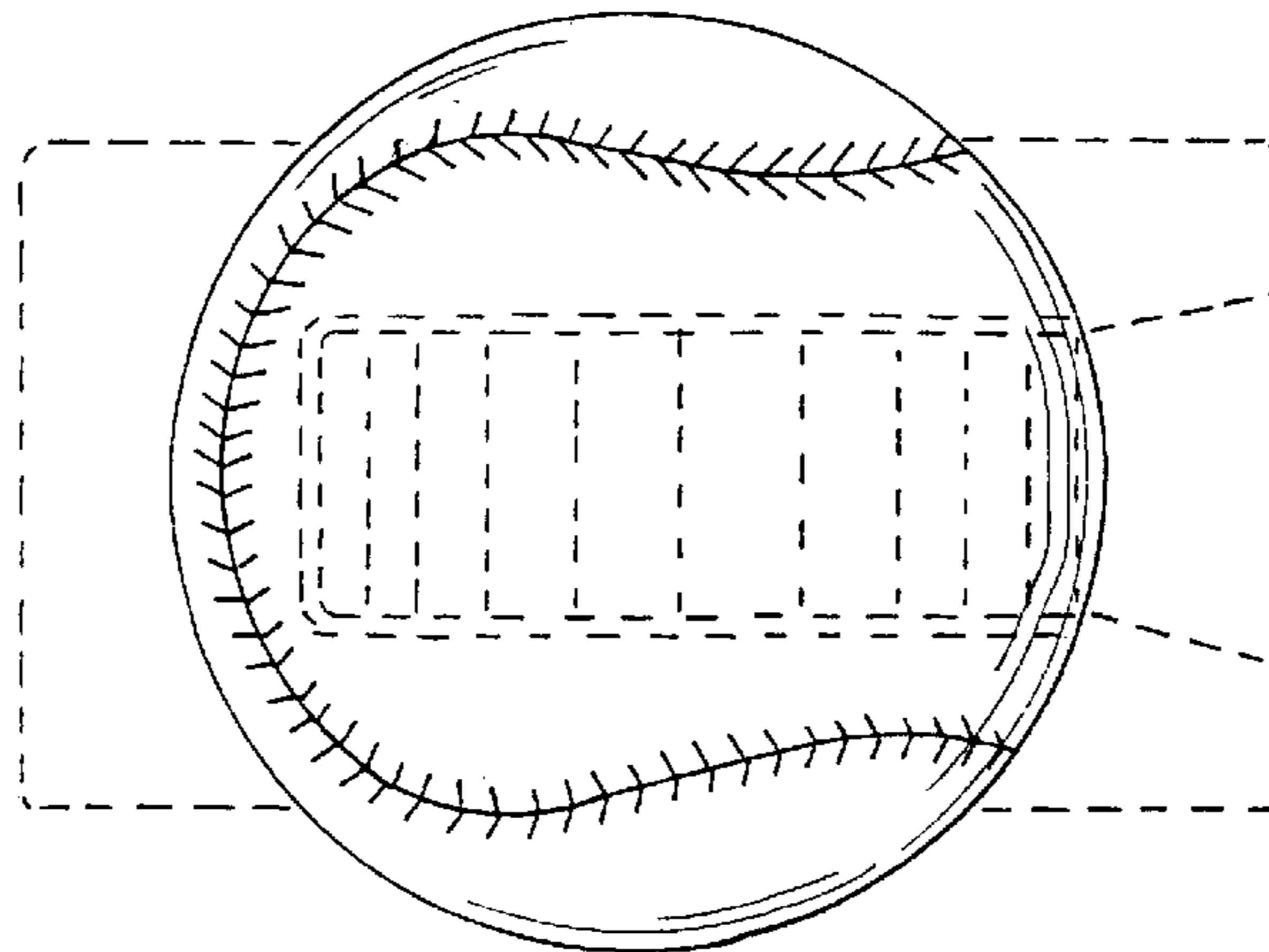

*Fig\_8*



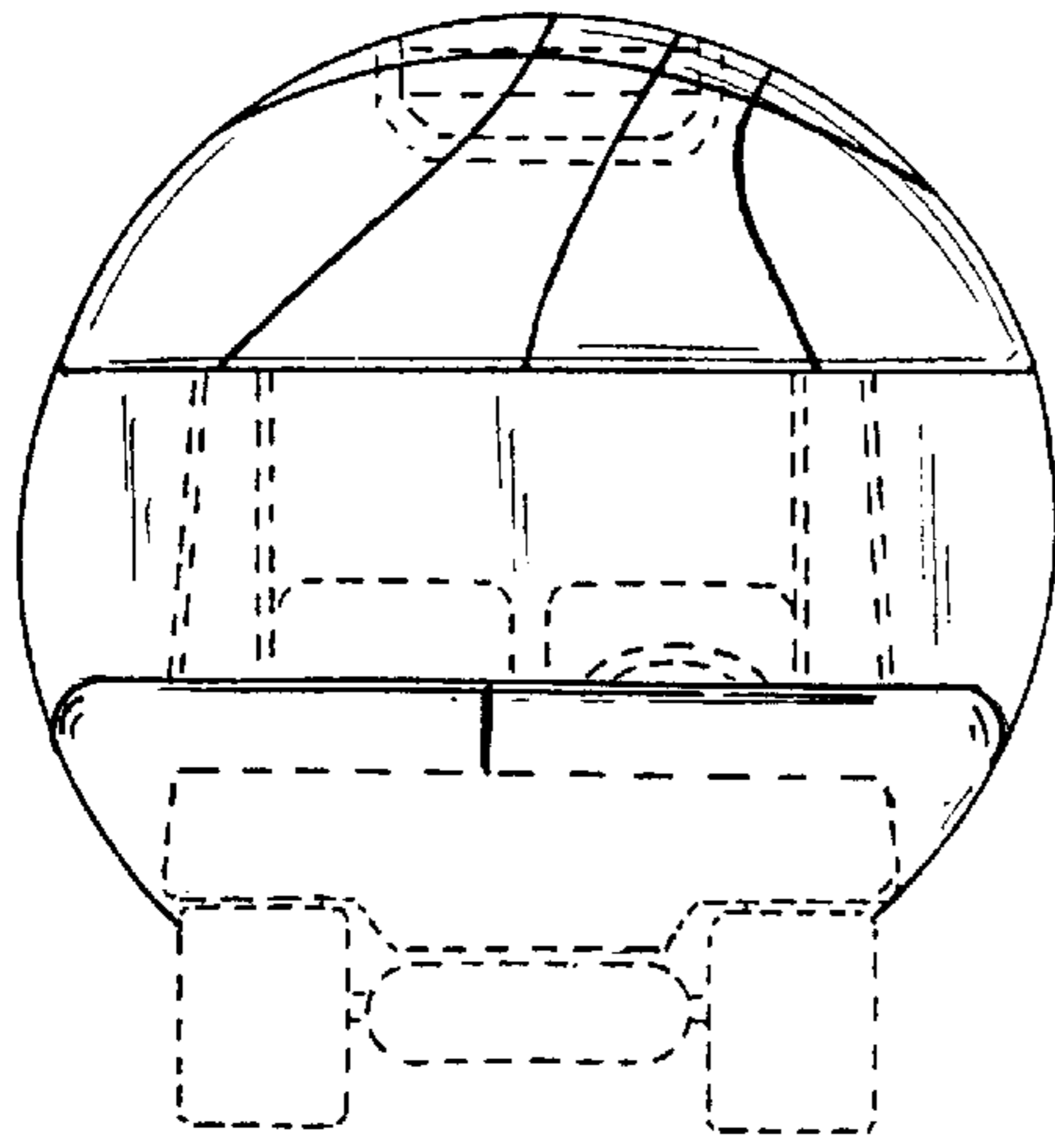

*Fig\_9*

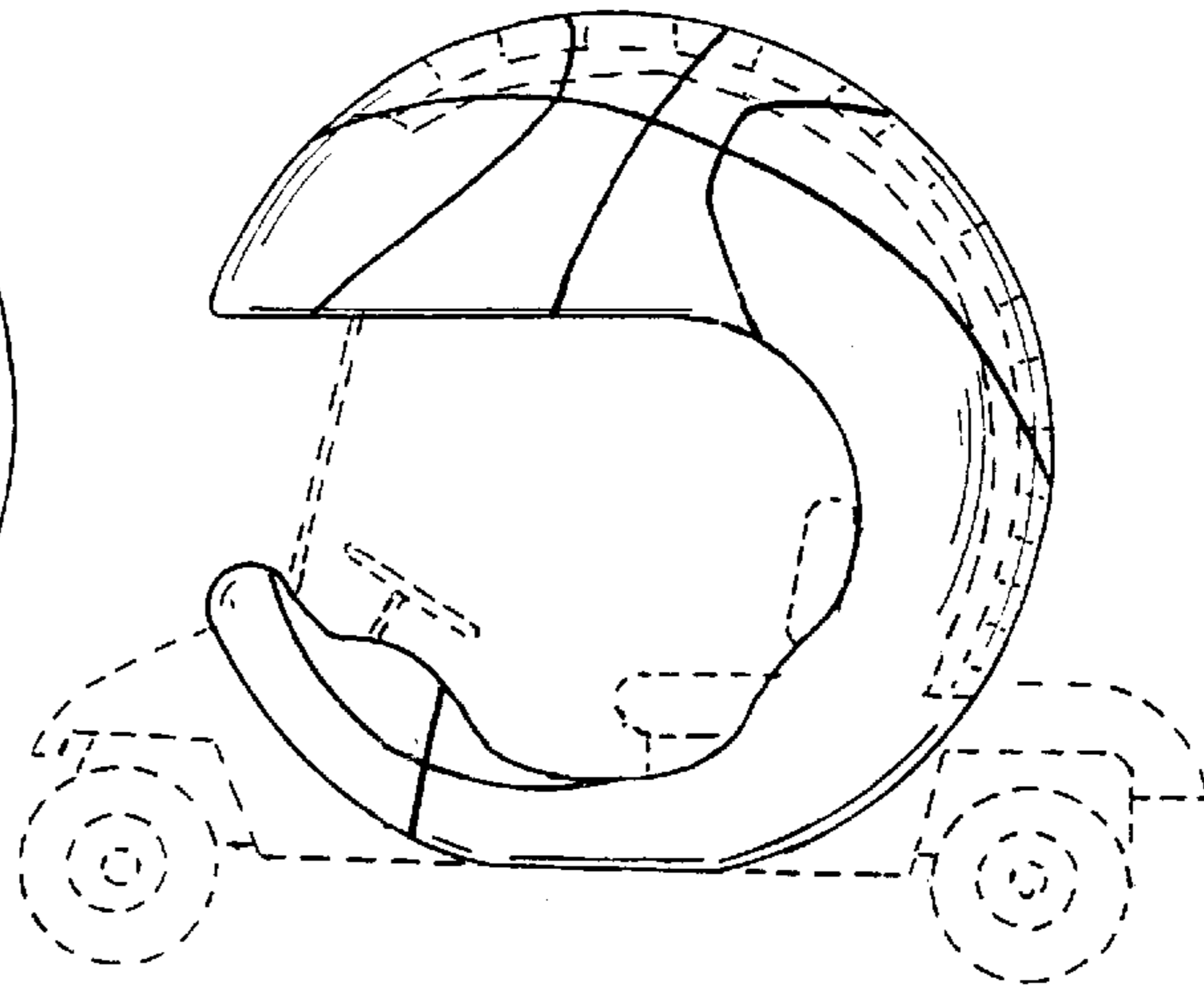

*Fig\_10*

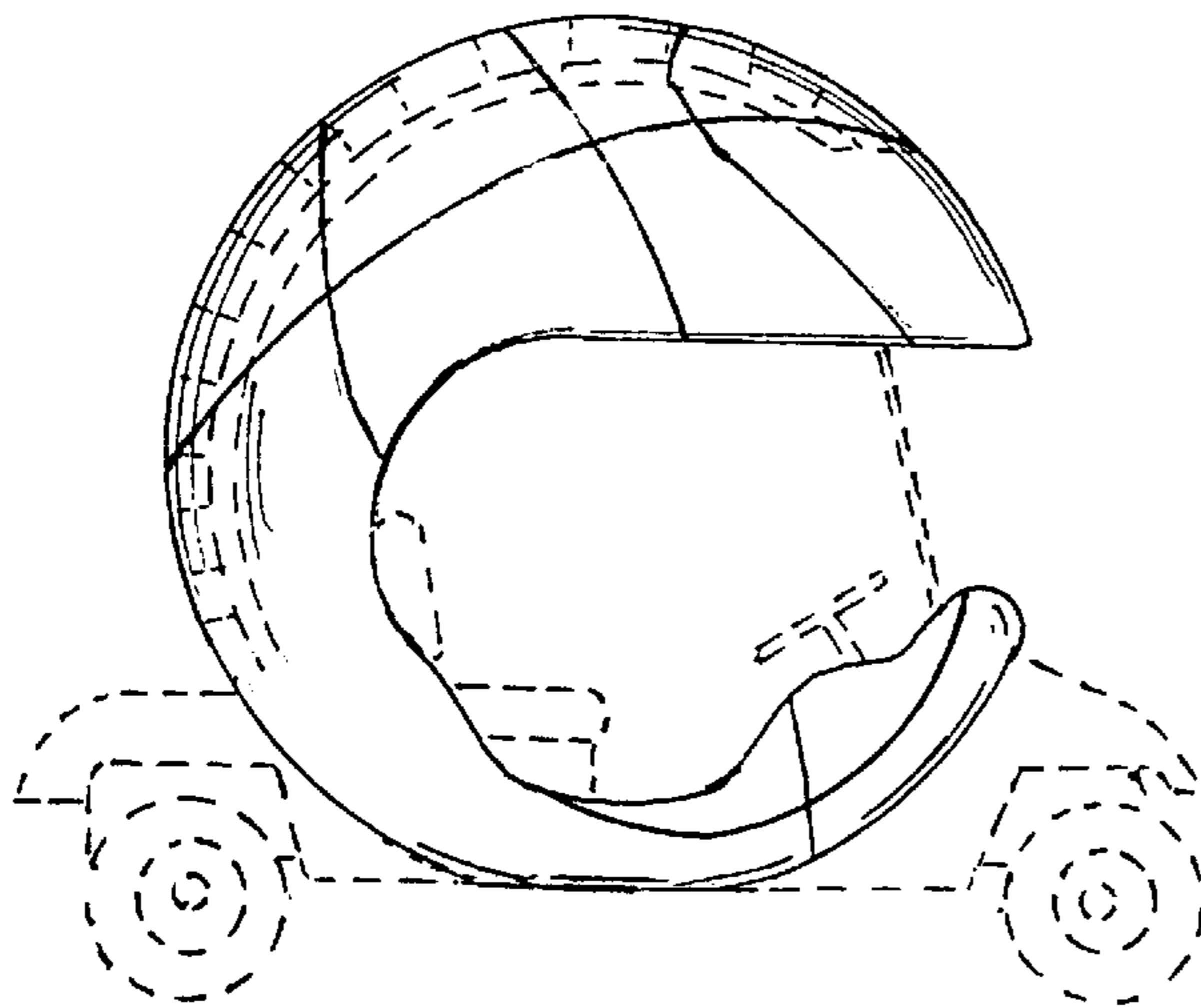

*Fig\_11*

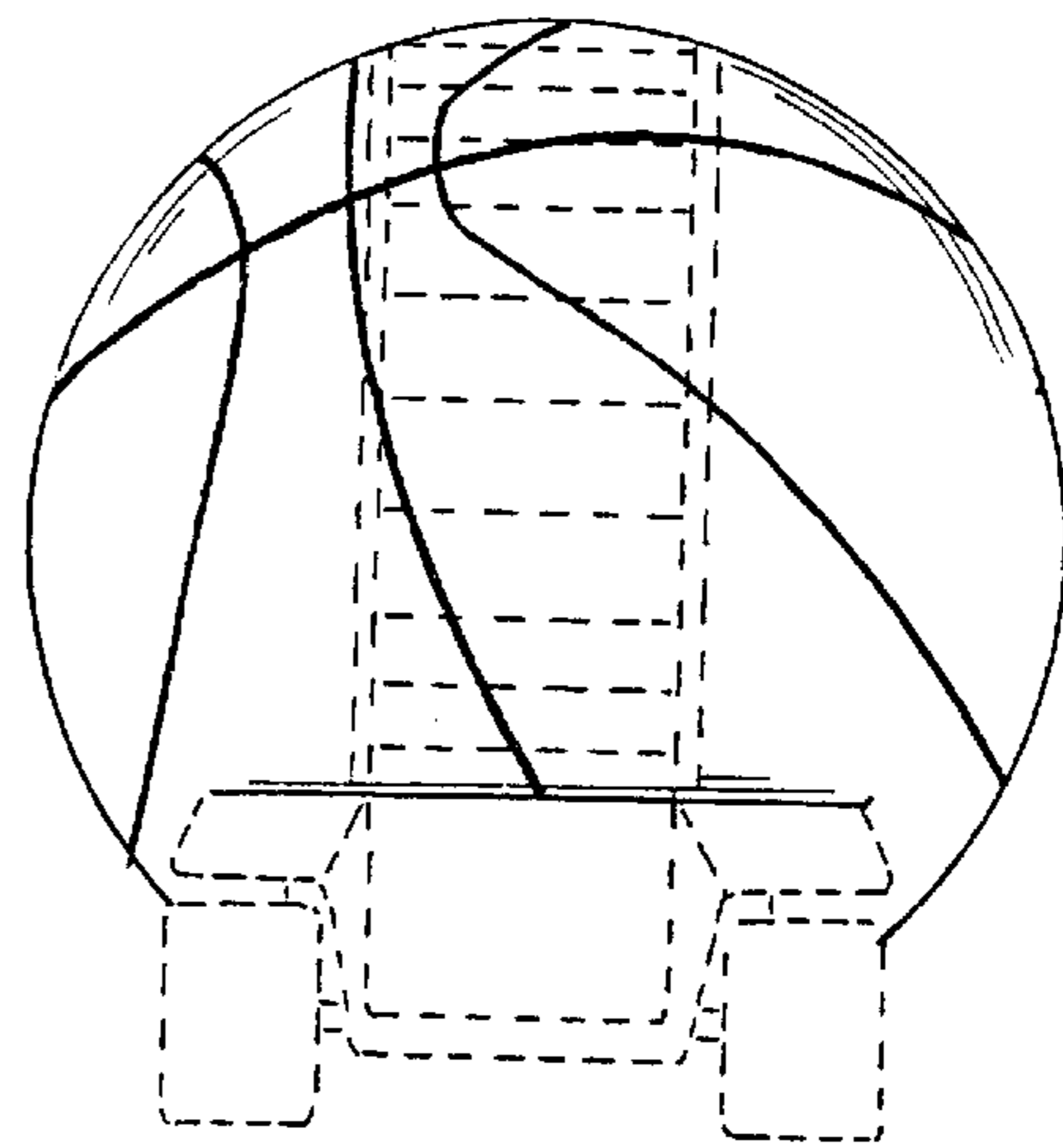

*Fig\_12*

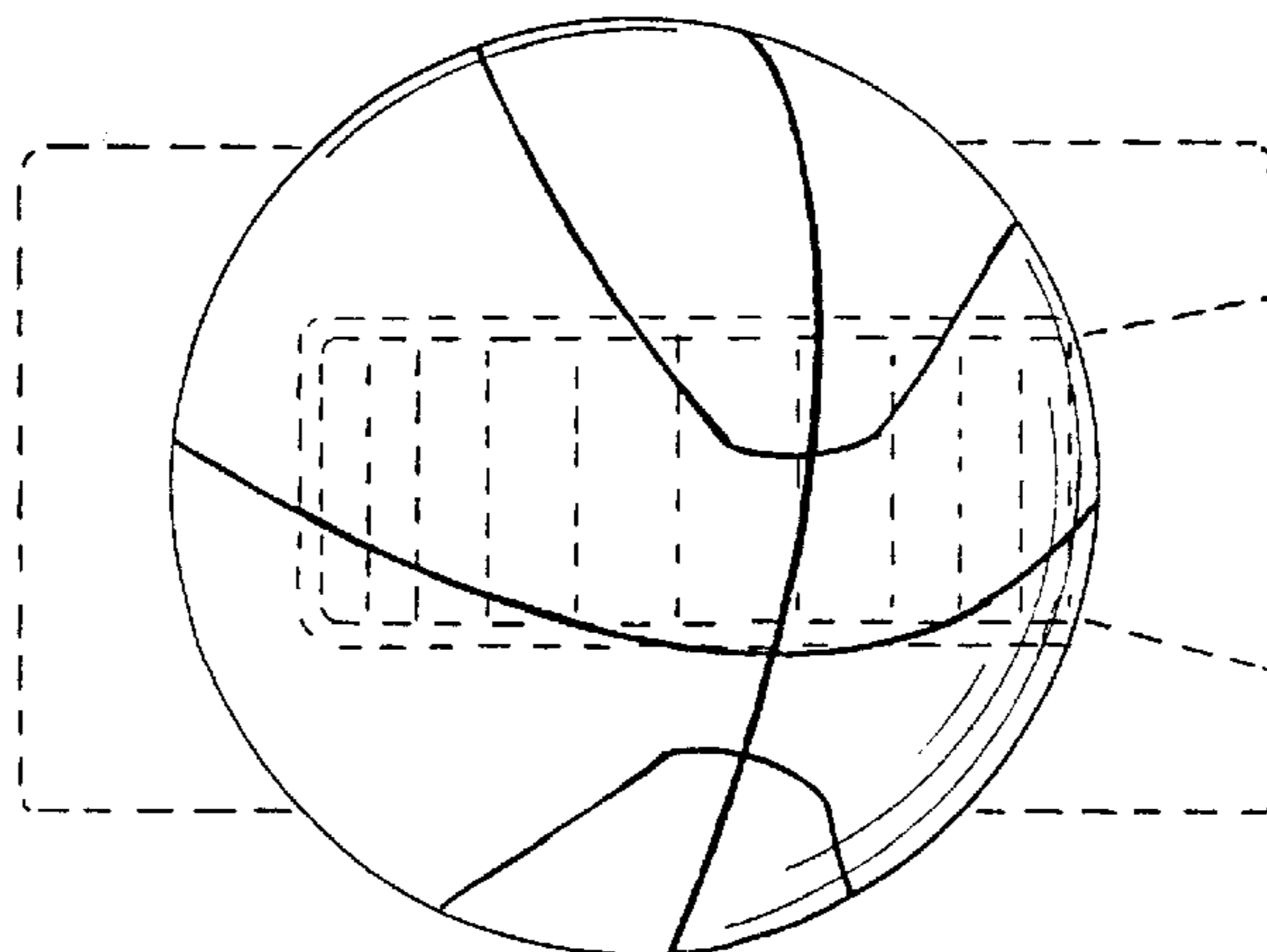

*Fig\_13*

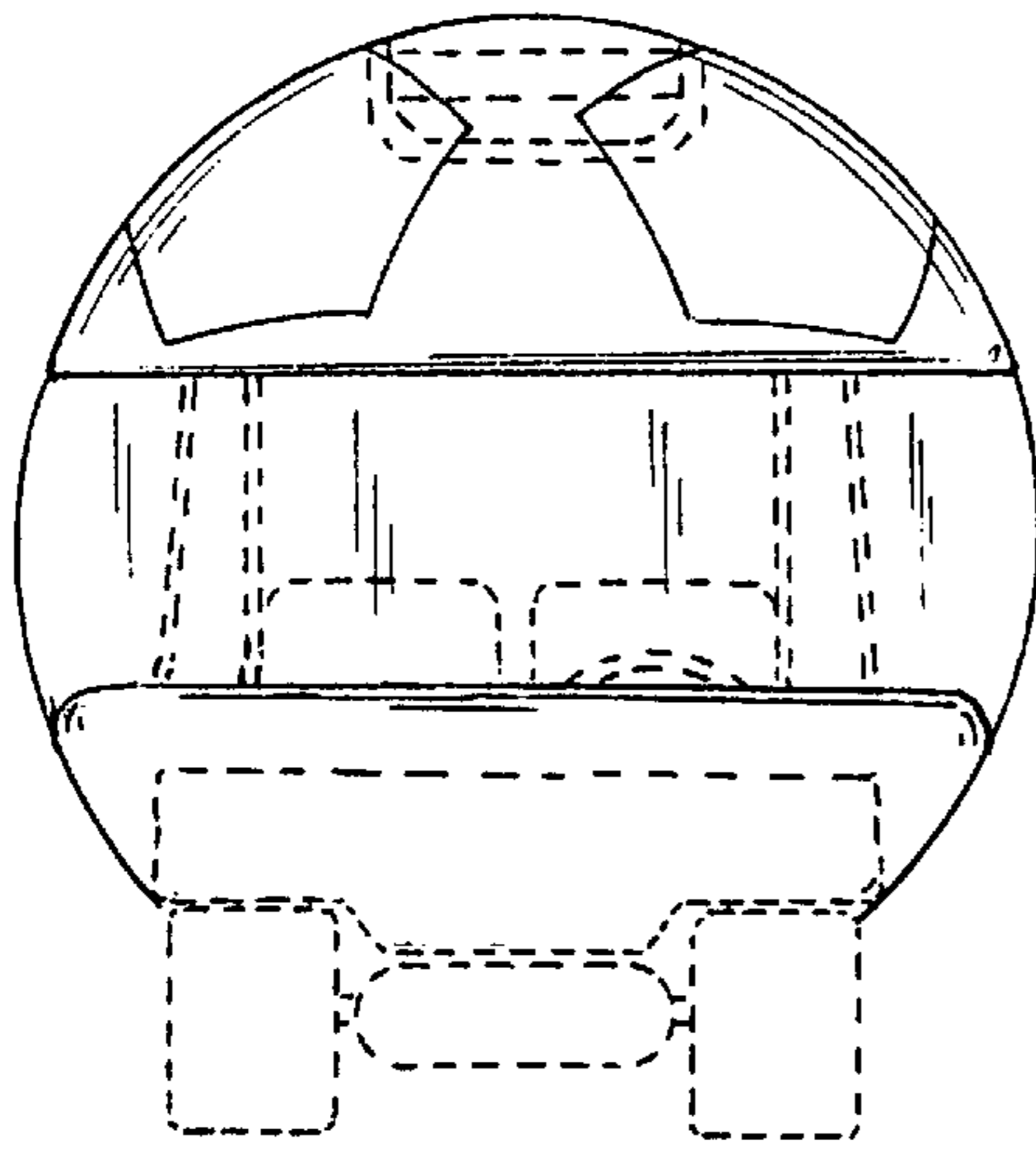

*Fig\_14*

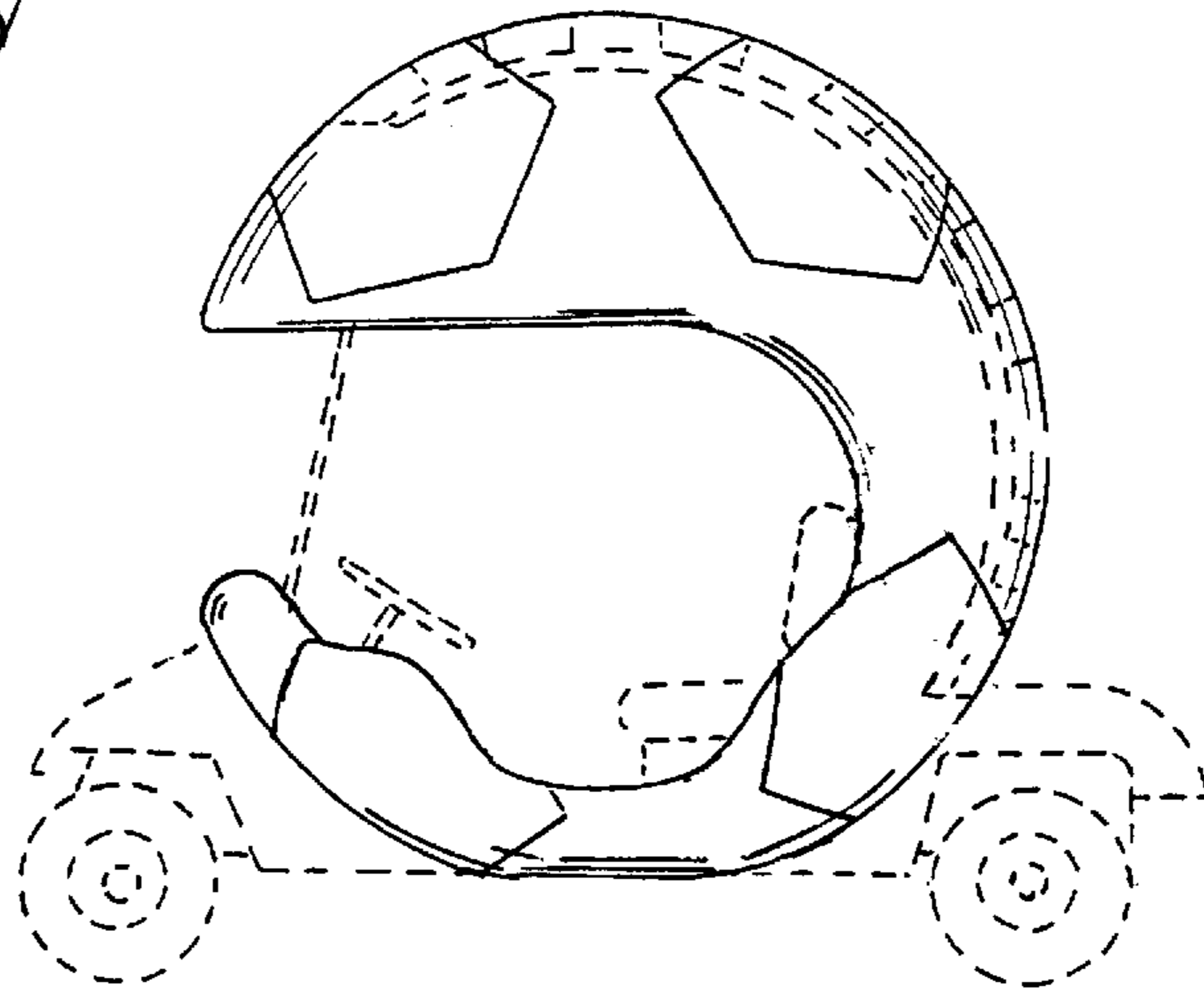

*Fig\_15*

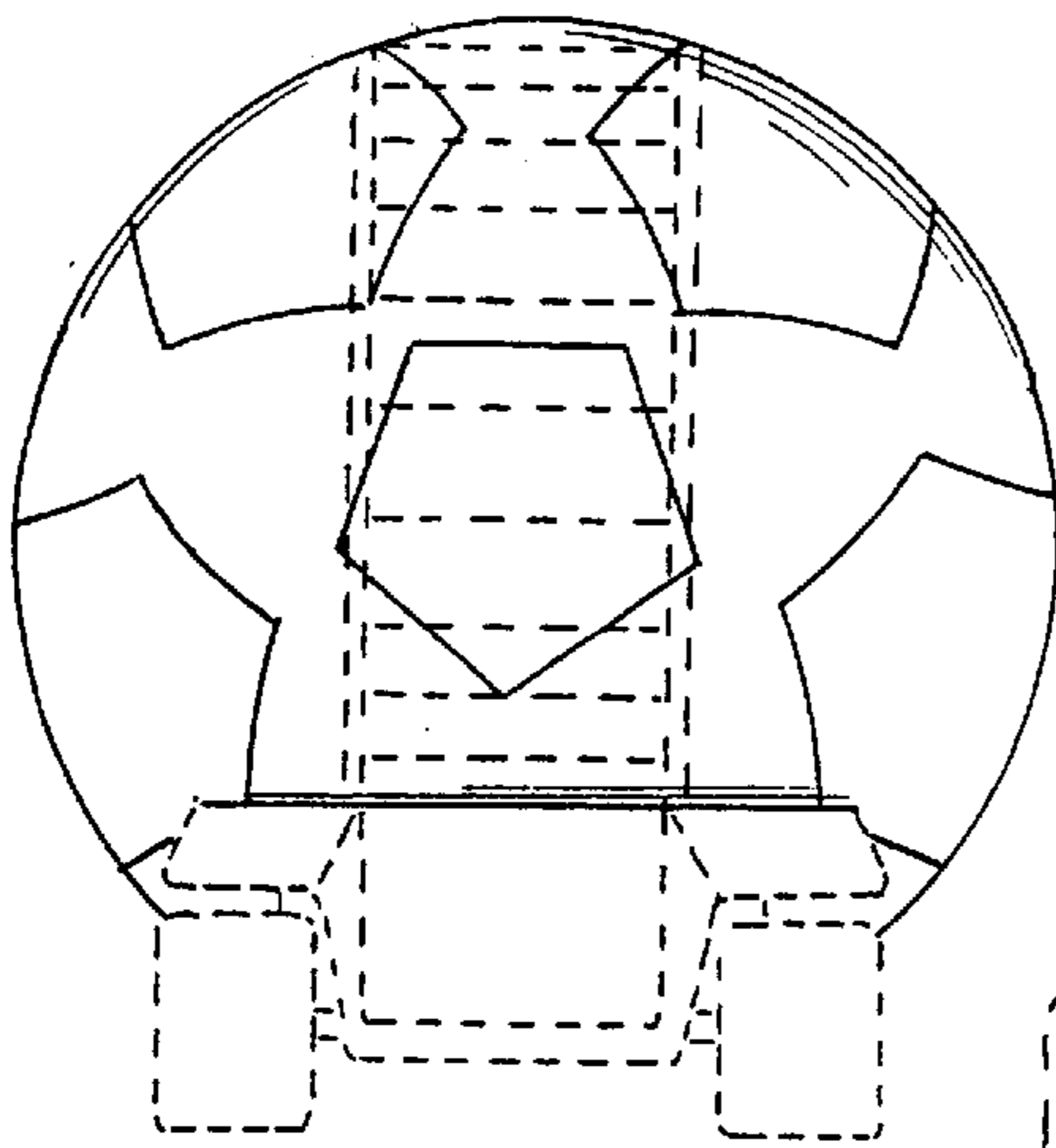

*Fig\_16*

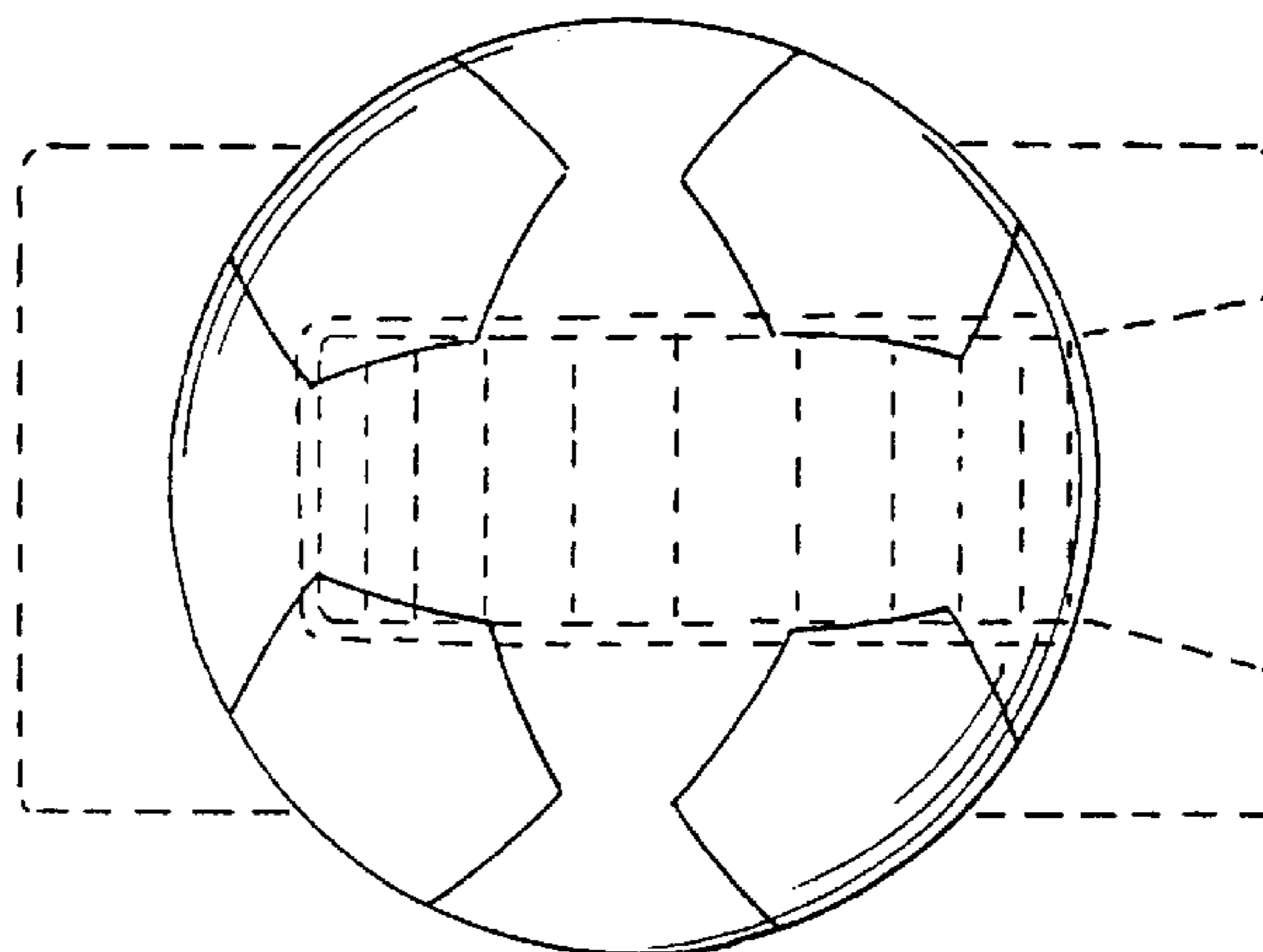

*Fig\_17*

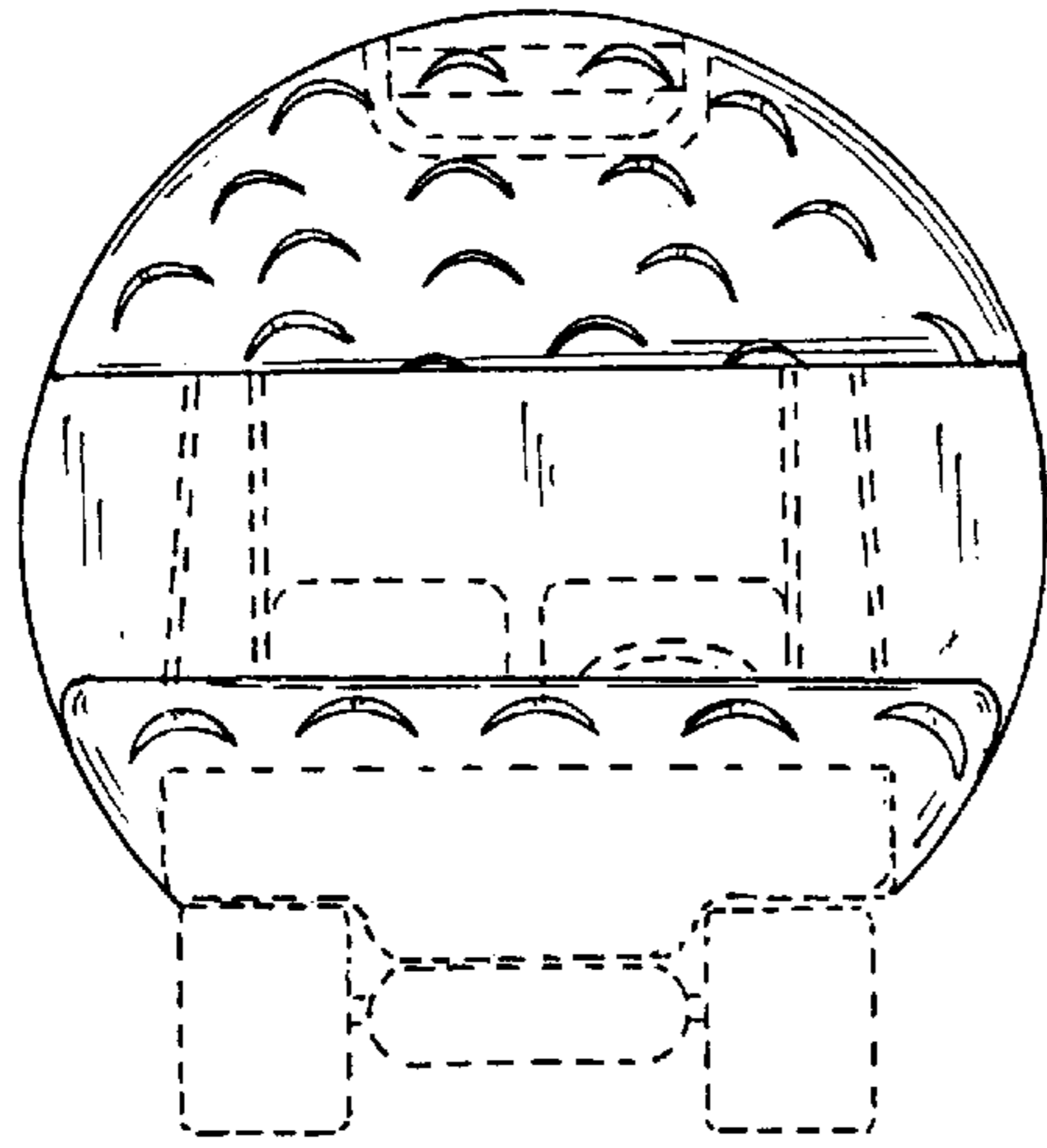

*Fig\_18*

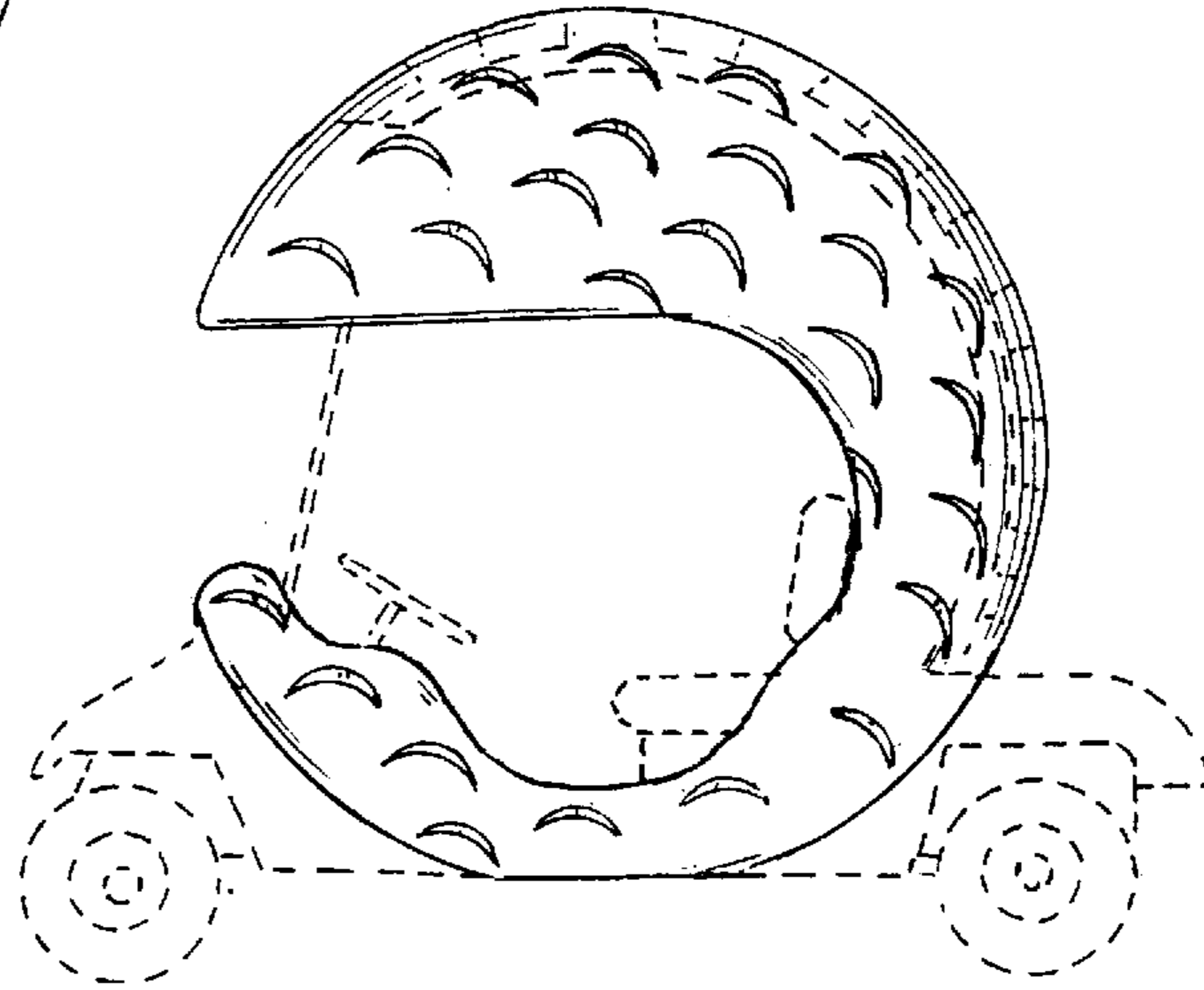

*Fig\_19*

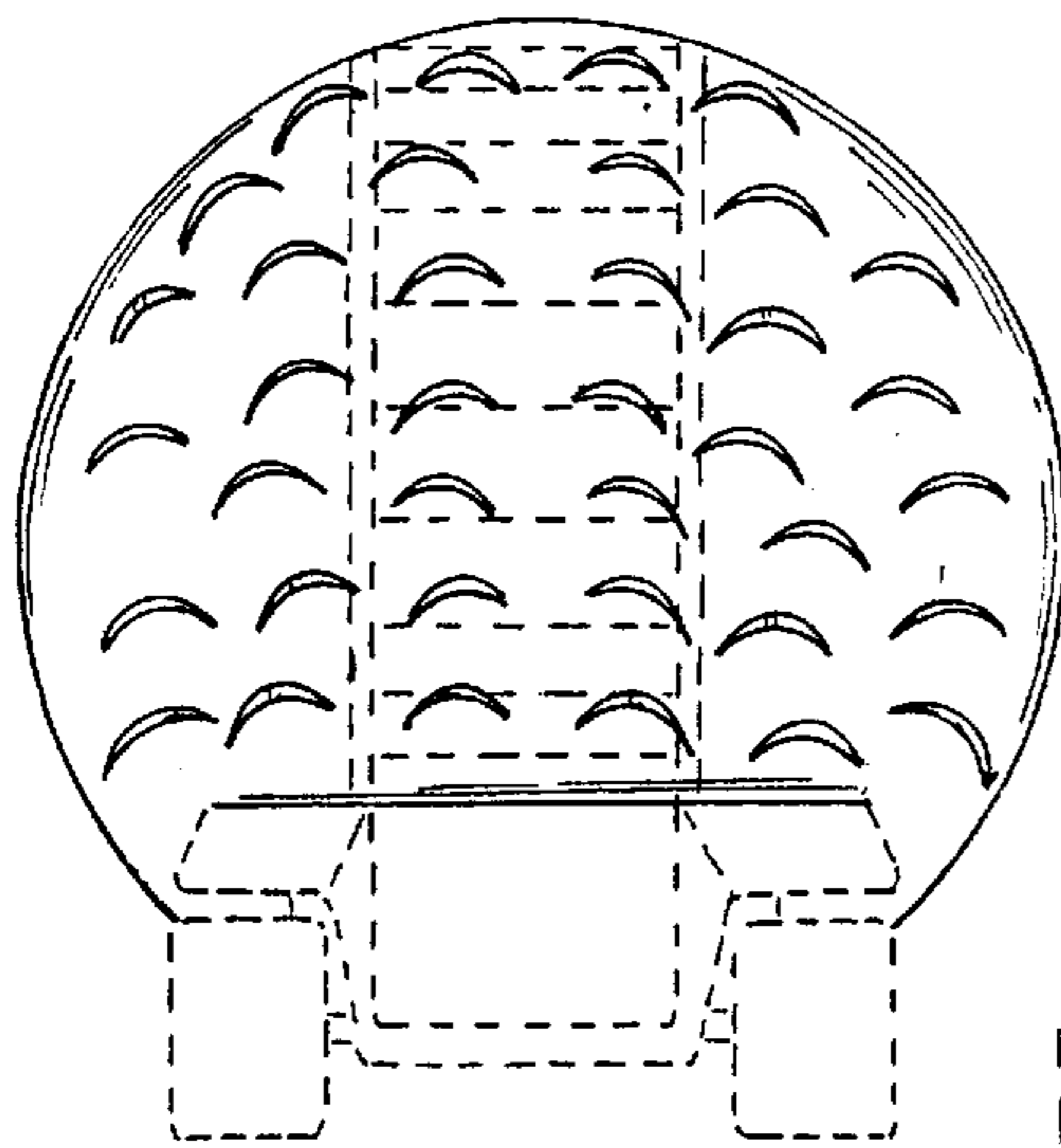

*Fig\_20*

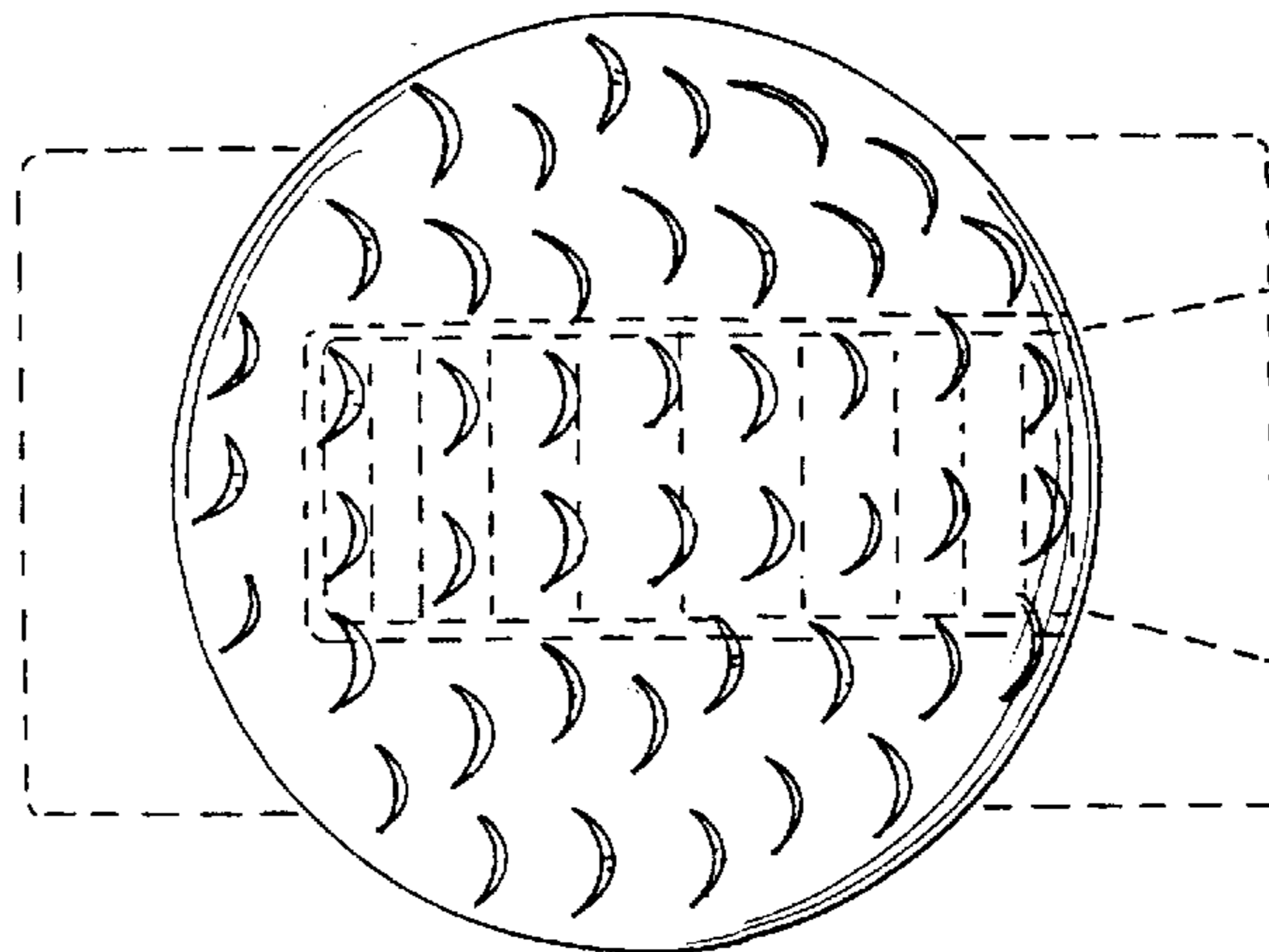

*Fig\_21*