



US00D471727S

(12) **United States Design Patent**  
**King et al.**

(10) **Patent No.:** **US D471,727 S**

(45) **Date of Patent:** **\*\* Mar. 18, 2003**

(54) **COMBINATION INFANT CAR SEAT AND STROLLER**

5,318,311 A \* 6/1994 Bofill ..... 280/648  
D358,058 S \* 5/1995 Anthony et al. .... D6/333  
5,829,770 A \* 11/1998 Chiu ..... 280/204

(75) Inventors: **William L. King**, Denver, CO (US);  
**Glenn Schmierer**, Golden, CO (US)

\* cited by examiner

(73) Assignee: **Samsonite Corporation**, Denver, CO (US)

*Primary Examiner*—Doris V. Coles

*Assistant Examiner*—Mimosa De

(74) *Attorney, Agent, or Firm*—Gregory W. O'Connor

(\*\*) Term: **14 Years**

(57) **CLAIM**

(21) Appl. No.: **29/155,584**

The ornamental design for combination infant car seat and stroller, as shown and described.

(22) Filed: **Feb. 18, 2002**

**DESCRIPTION**

(51) **LOC (7) Cl.** ..... **06-01**

(52) **U.S. Cl.** ..... **D6/333; D6/335**

(58) **Field of Search** ..... D6/333, 334, 335,  
D6/500–502; D12/129; 297/250.1, 256.16,  
256.15; 280/642, 648, 204

FIG. 1 is a perspective view showing the upper right front of the combination infant car seat and stroller, the upper left front view being a mirror image thereof; and,

FIG. 2 is a perspective view showing the upper right rear of the combination infant car seat and stroller, the upper left rear view being a mirror image thereof.

The bottom surface of the combination infant car seat and stroller, while not featureless, is disclaimed and forms no part of this design.

(56) **References Cited**

**U.S. PATENT DOCUMENTS**

4,828,281 A \* 5/1989 Sanchas ..... 280/648  
D310,054 S \* 8/1990 Tucker et al. .... D12/129

**1 Claim, 1 Drawing Sheet**

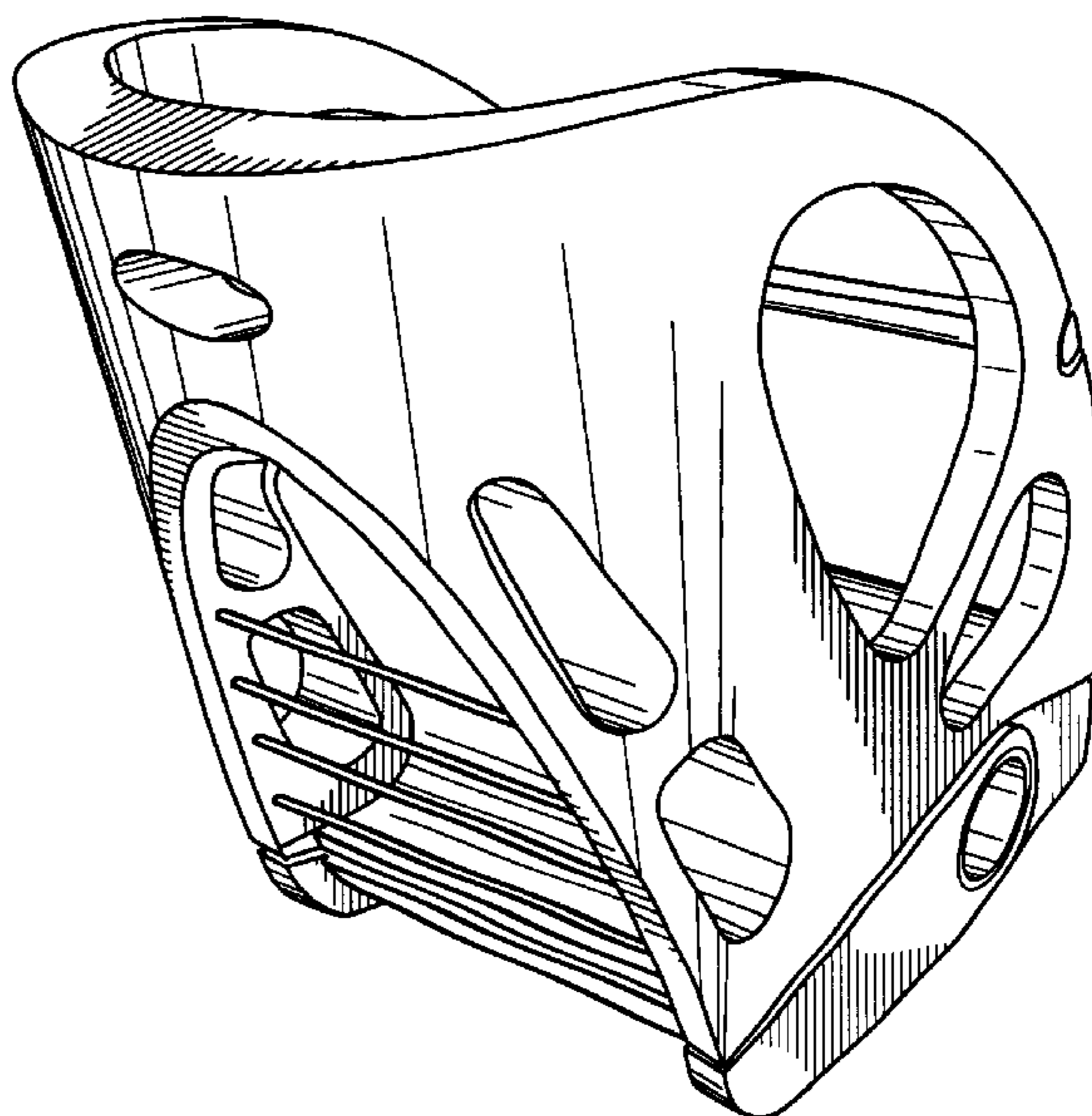
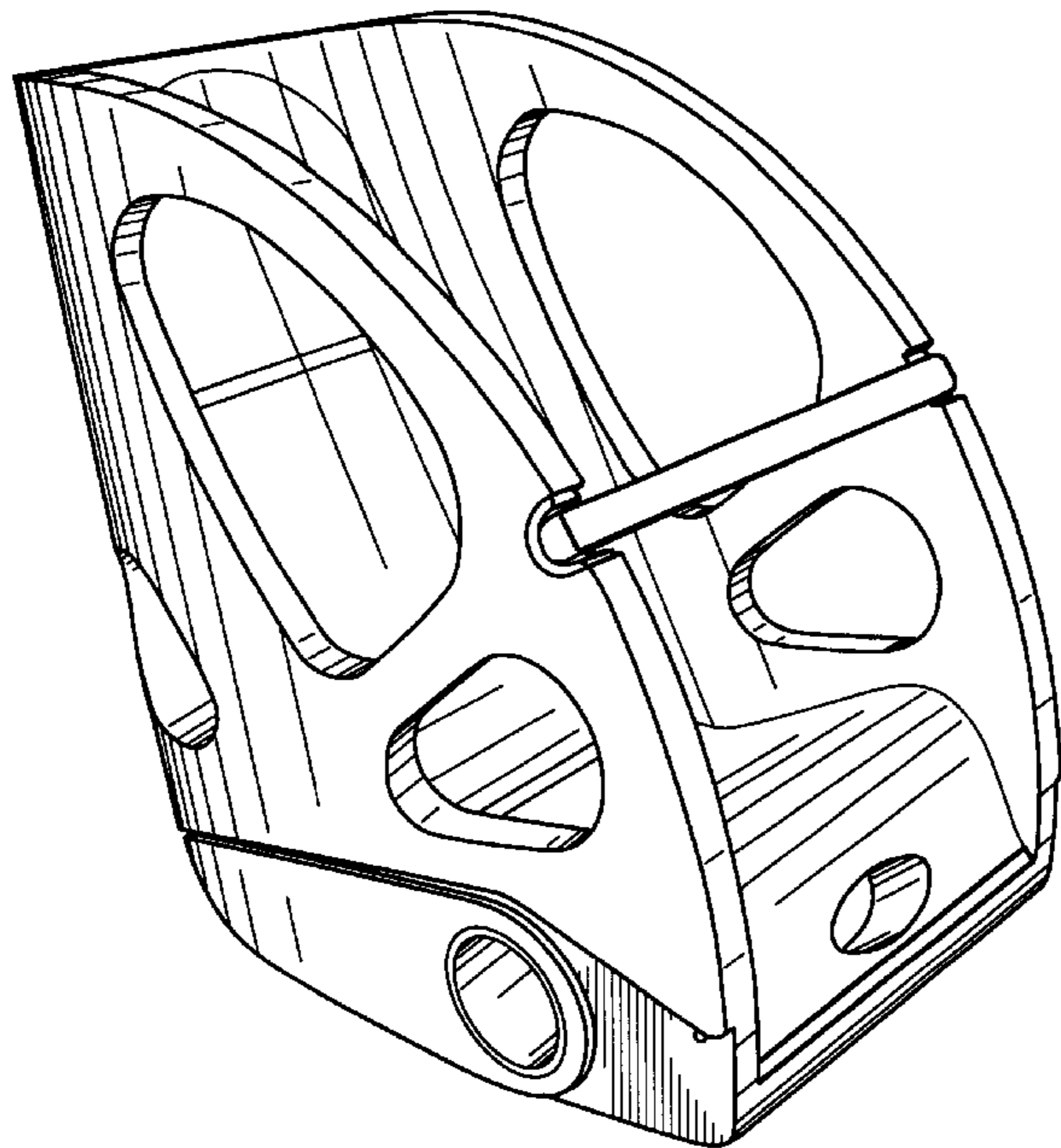

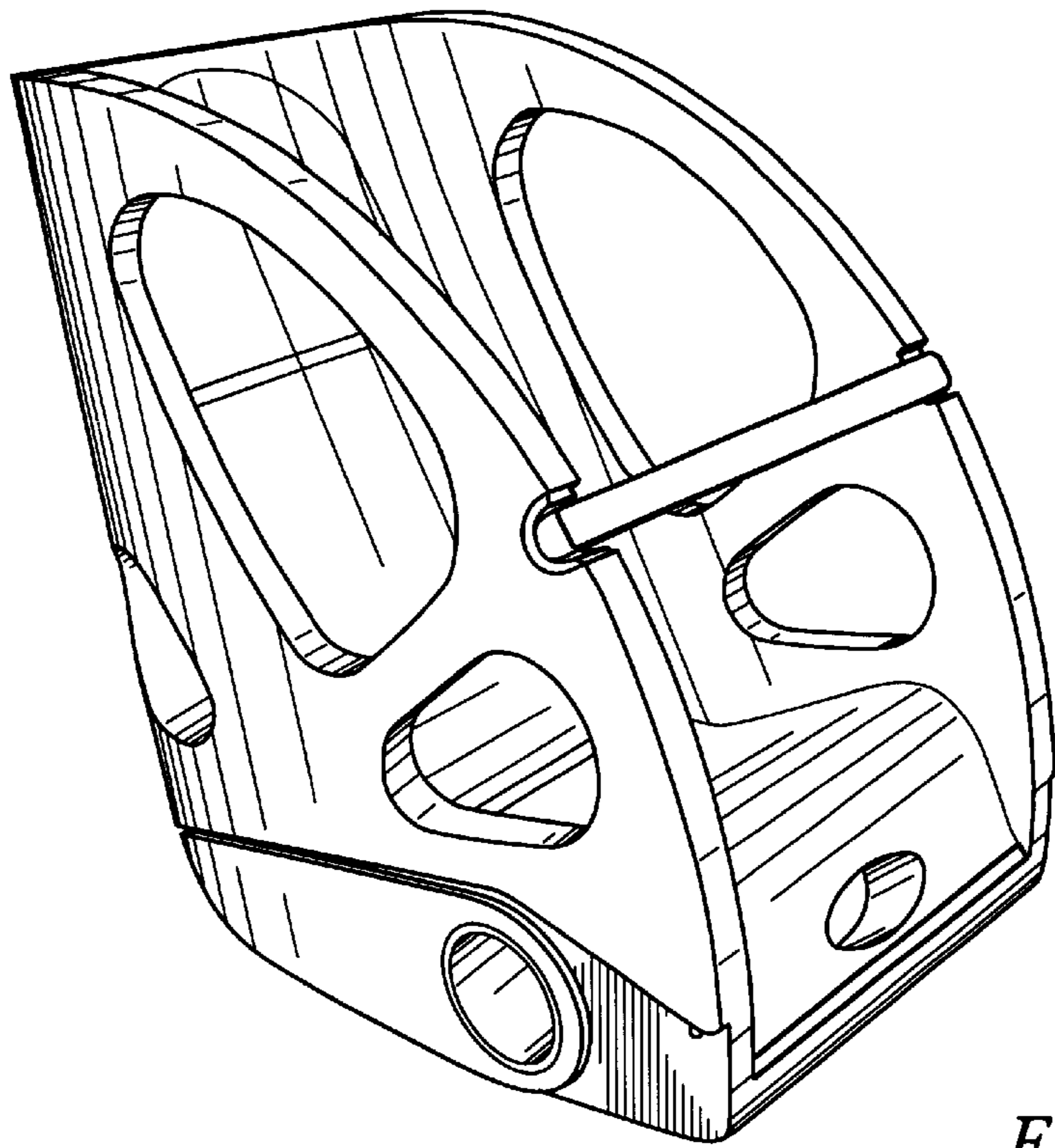

FIG. 1

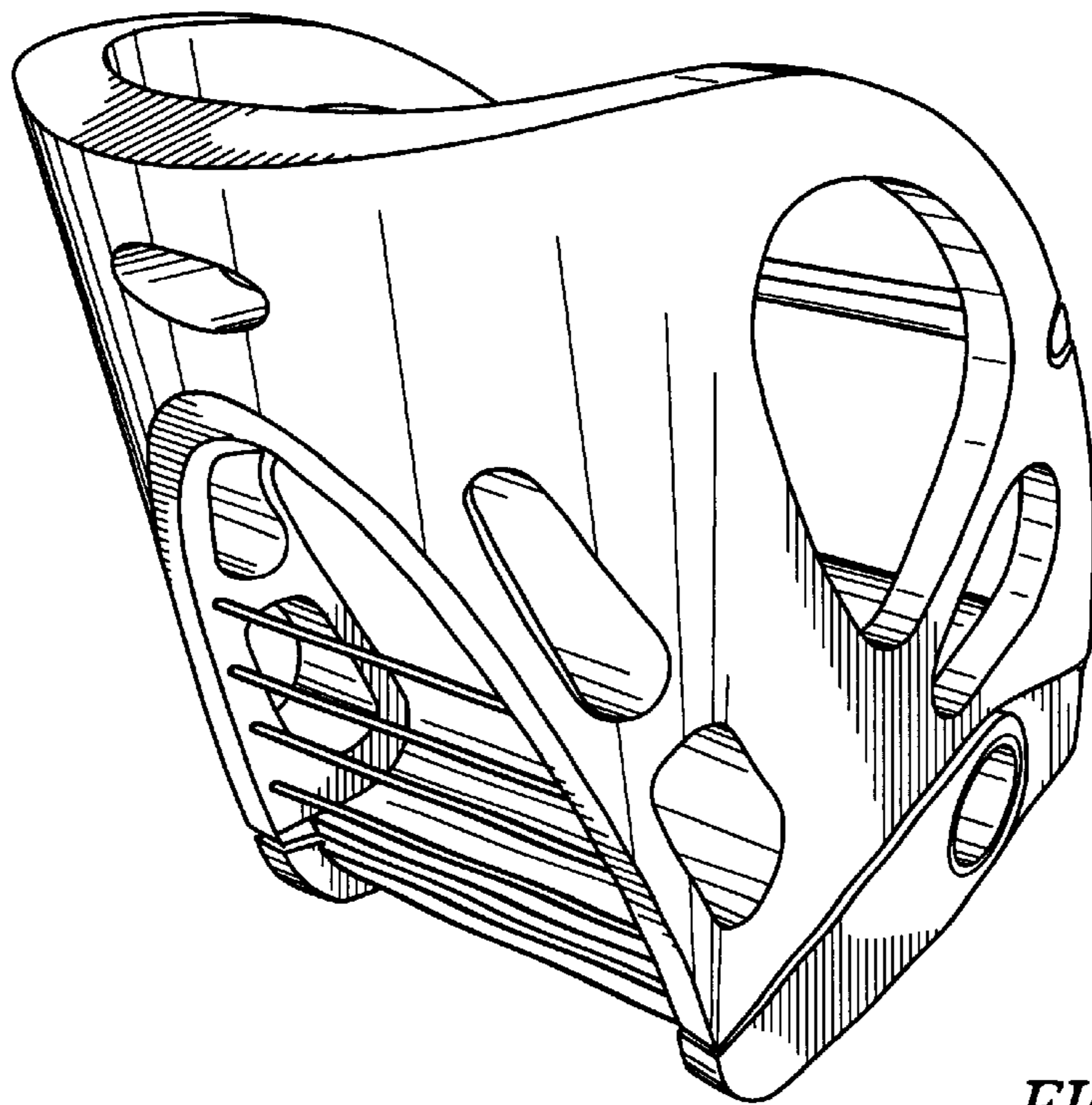

FIG. 2