



US00D471495S

(12) **United States Design Patent**
Hoyle, Jr.

(10) **Patent No.:** **US D471,495 S**

(45) **Date of Patent:** **** Mar. 11, 2003**

- (54) **VEHICLE DOUBLE COWL**
- (75) Inventor: **Frederick L. Hoyle, Jr.**, Pickerington, OH (US)
- (73) Assignee: **Reflexion Automotive Products, LLP**, Memphis, TN (US)
- (**) Term: **14 Years**
- (21) Appl. No.: **29/153,617**
- (22) Filed: **Jan. 14, 2002**
- (51) **LOC (7) Cl.** **12-16**
- (52) **U.S. Cl.** **D12/173**
- (58) **Field of Search** D12/173, 196, D12/90-92; 180/69.21, 69.2, 69.22

- D430,084 S 8/2000 Hoyle, Jr.
- D430,085 S 8/2000 Hoyle, Jr.
- D433,359 S 11/2000 Hoyle, Jr.
- D446,175 S 8/2001 Hoyle, Jr.
- D461,434 S 8/2002 Hoyle, Jr. D12/173

* cited by examiner

Primary Examiner—Melody N. Brown
(74) *Attorney, Agent, or Firm*—Jacobson Holman PLLC

(57) **CLAIM**

The ornamental design for a vehicle double cowl, as shown and described.

DESCRIPTION

FIG. 1 is a perspective view of a vehicle double cowl showing my new design;
 FIG. 2 is a top plan view of the vehicle double cowl of FIG. 1;
 FIG. 3 is a right side elevational view of the vehicle double cowl of FIG. 1, the left side elevational view being a mirror image thereof;
 FIG. 4 is a front elevational view of the vehicle double cowl of FIG. 1; and,
 FIG. 5 is a rear elevational view of the vehicle double cowl of FIG. 1.
 The broken line showing in the Figures is environmental only and forms no part of the claimed design.

(56) **References Cited**

U.S. PATENT DOCUMENTS

- 5,136,276 A 8/1992 Wayne
- D330,881 S * 11/1992 Masters D12/196
- D342,709 S 12/1993 Cervini
- D386,457 S 11/1997 Wittine
- D391,909 S 3/1998 Wittine
- D403,272 S * 12/1998 Cadotte et al. D12/7
- D416,524 S 11/1999 Gabath
- D418,465 S 1/2000 Alfes
- D427,122 S 6/2000 Hoyle, Jr.
- D427,123 S 6/2000 Hoyle, Jr.

1 Claim, 2 Drawing Sheets

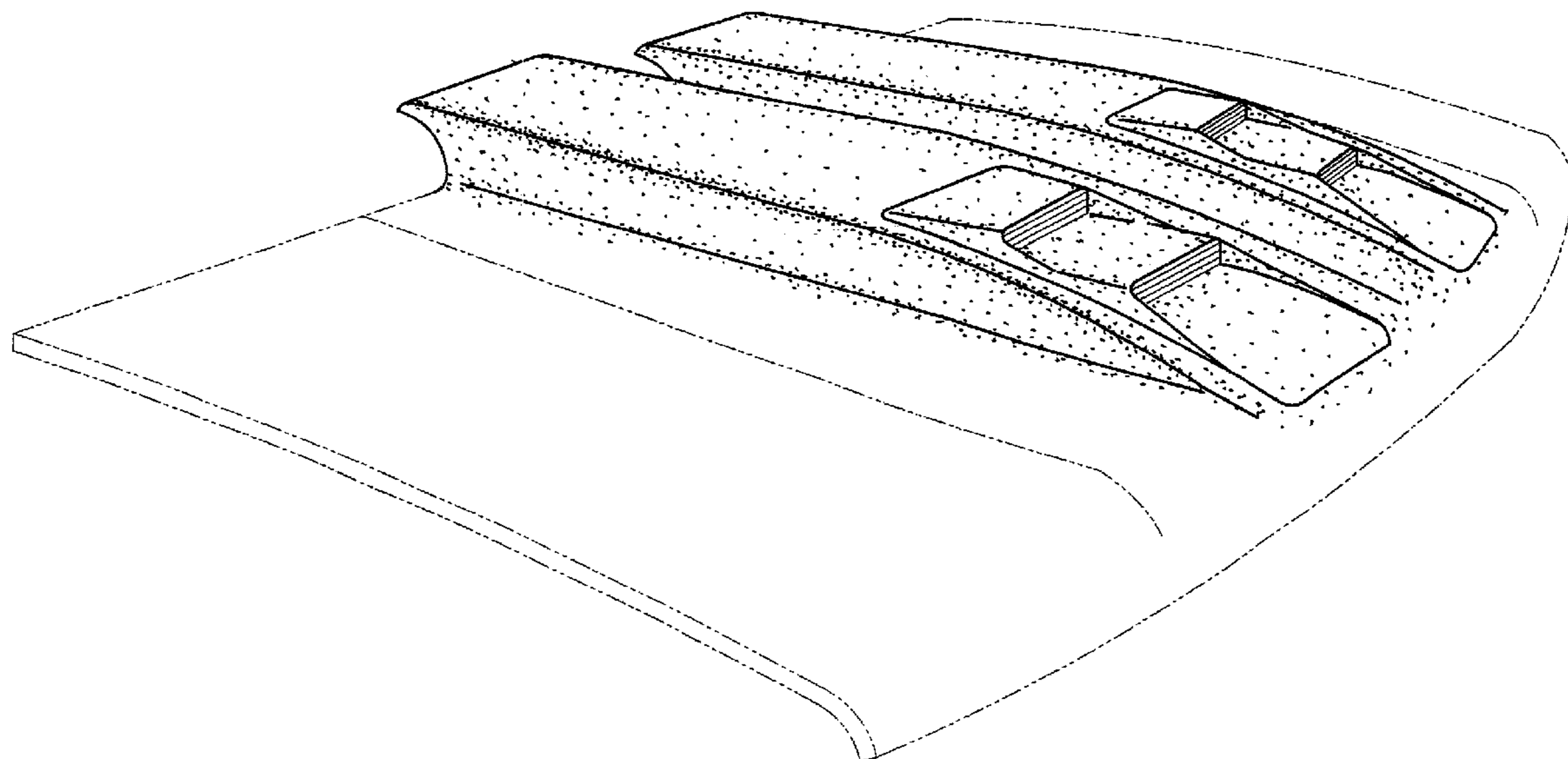

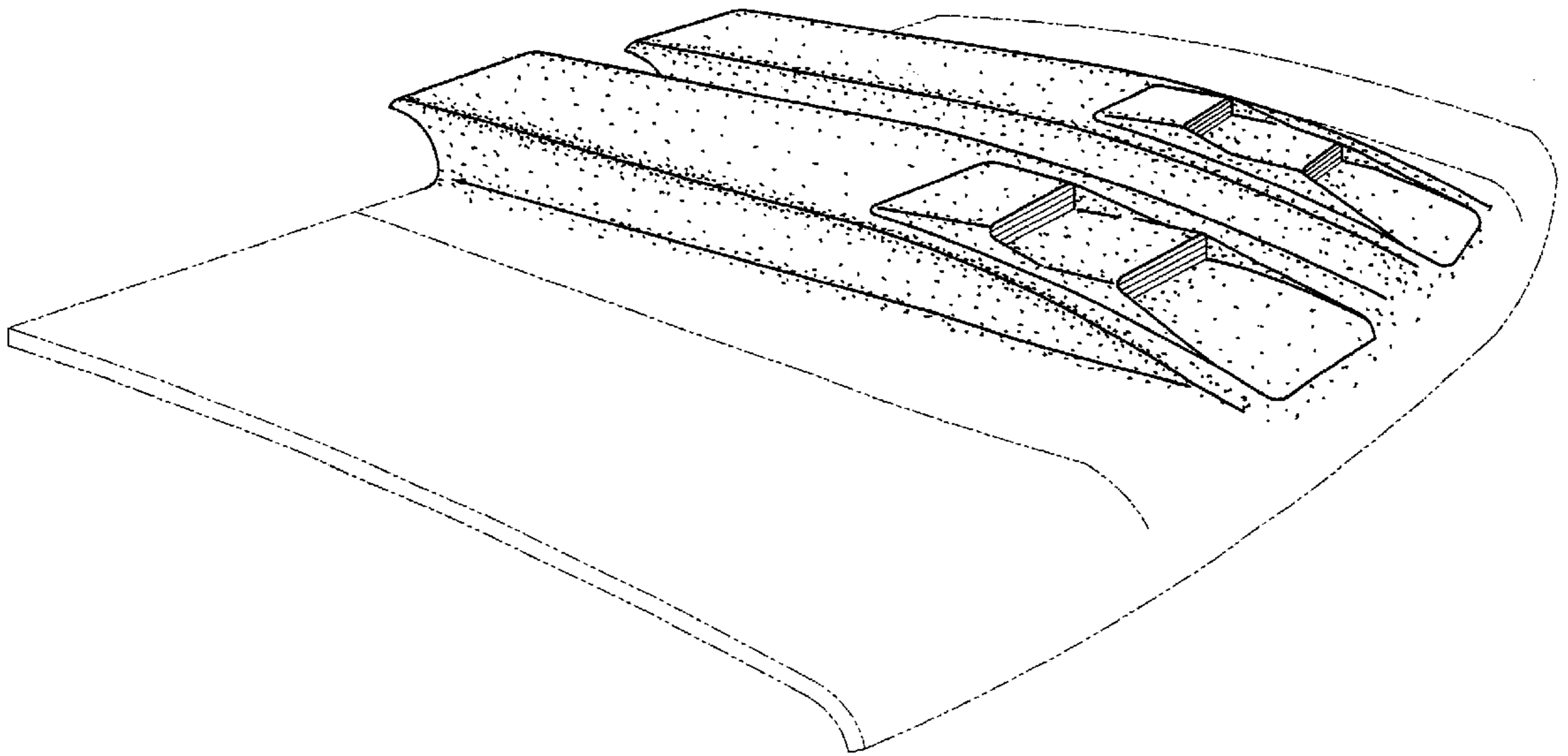

FIG. 1

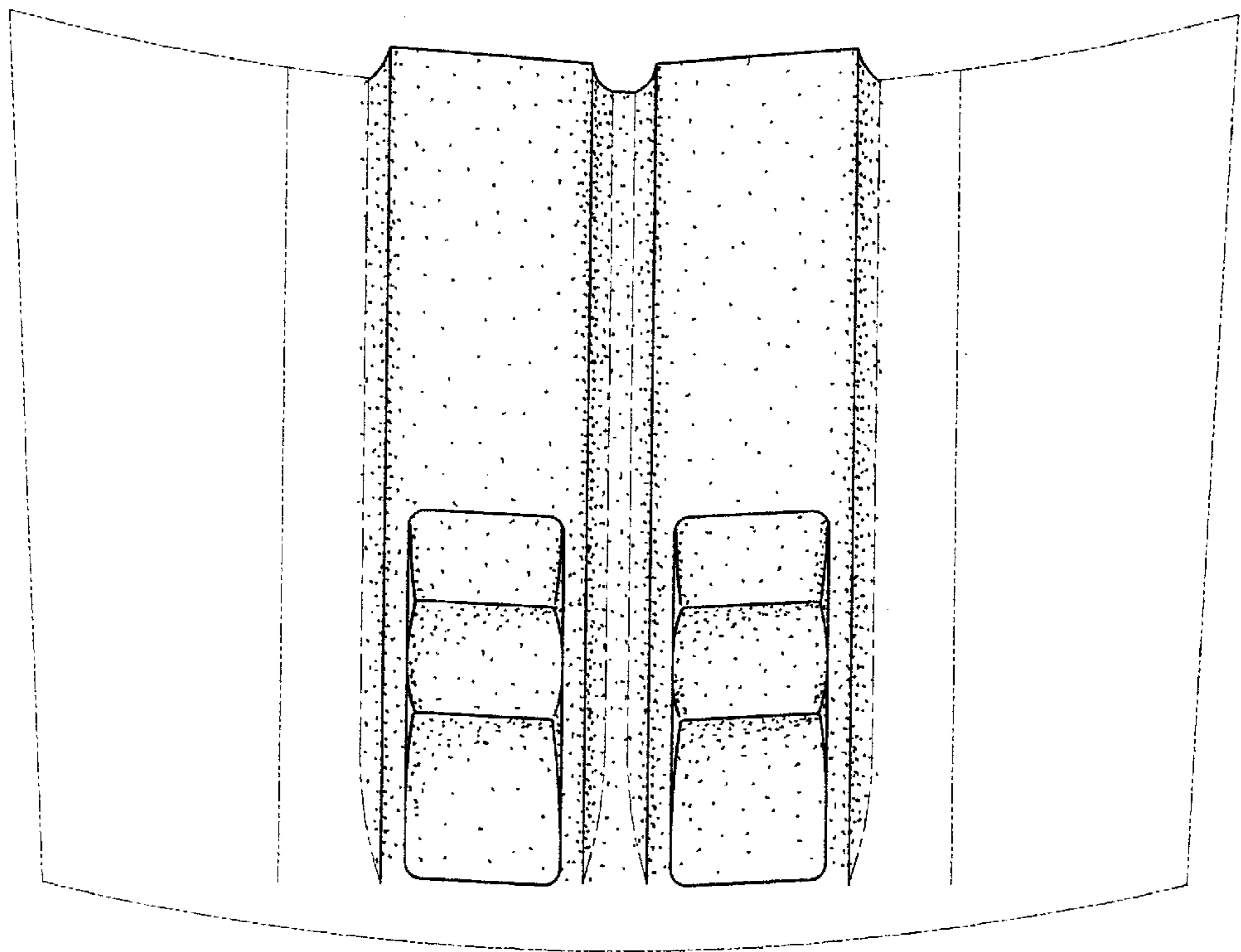

FIG. 2

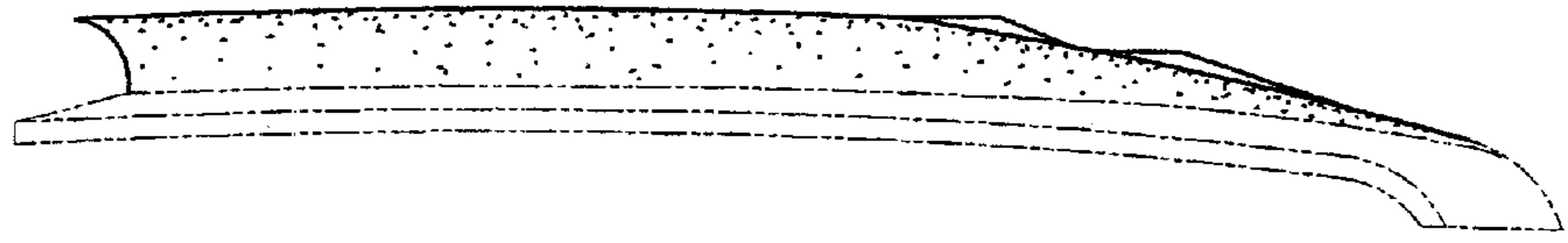

FIG. 3

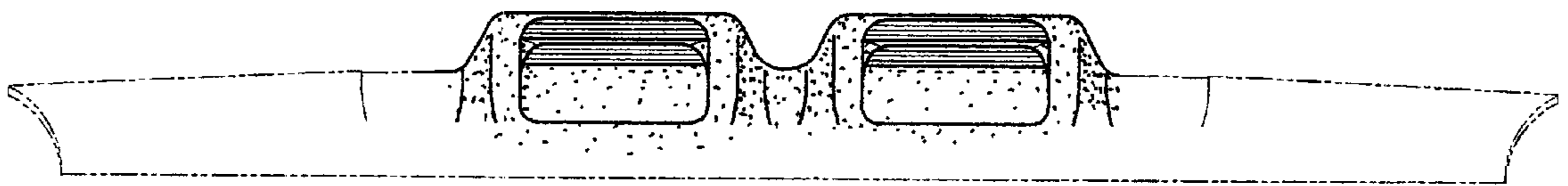

FIG. 4

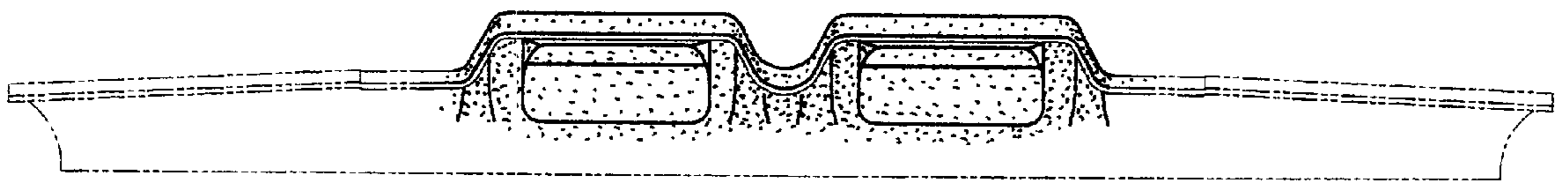

FIG. 5