



US00D470954S

(12) **United States Design Patent**
Isayama et al.

(10) **Patent No.:** **US D470,954 S**

(45) **Date of Patent:** **** Feb. 25, 2003**

(54) **HEADLIGHT**

FOREIGN PATENT DOCUMENTS

(75) Inventors: **Shinichi Isayama**, Hiroshima (JP);
Atsushi Yoshida, Hiroshima (JP);
Kouichi Hayashi, Hiroshima (JP);
Kunihiko Kurisu, Hiroshima (JP)

JP 1143790 6/2002

OTHER PUBLICATIONS

Notice of Reasons for Rejection, Japanese Design Application No. 2002-000435, Mailing date: Sep. 2, 2002.

(73) Assignee: **Mazda Motor Corporation**,
Hiroshima-ken (JP)

* cited by examiner

(**) Term: **14 Years**

Primary Examiner—Marcus A. Jackson

(21) Appl. No.: **29/157,467**

(74) *Attorney, Agent, or Firm*—Nixon Peabody LLP;
Donald R. Studebaker

(22) Filed: **Mar. 21, 2002**

(57) **CLAIM**

(30) **Foreign Application Priority Data**

The ornamental design for a headlight, as shown and described.

Jan. 10, 2002 (JP) 2002-000435

DESCRIPTION

(51) **LOC (7) Cl.** **26-06**

FIG. 1 is a perspective view of a headlight;

(52) **U.S. Cl.** **D26/28**

FIG. 2 is a front view thereof;

(58) **Field of Search** D26/28-36; 362/61,
362/80, 81, 82, 83, 83.3, 83.4, 267, 269,
275

FIG. 3 is a rear view thereof;

FIG. 4 is a left side view thereof;

FIG. 5 is a right side view thereof;

FIG. 6 is a top view thereof; and,

FIG. 7 is a bottom view thereof.

(56) **References Cited**

Portion in broken lines is shown for illustrative purposes only and forms no part of the claimed design.

U.S. PATENT DOCUMENTS

D459,510 S * 6/2002 Horowitz D26/28

D459,821 S * 7/2002 Horowitz D26/28

1 Claim, 4 Drawing Sheets

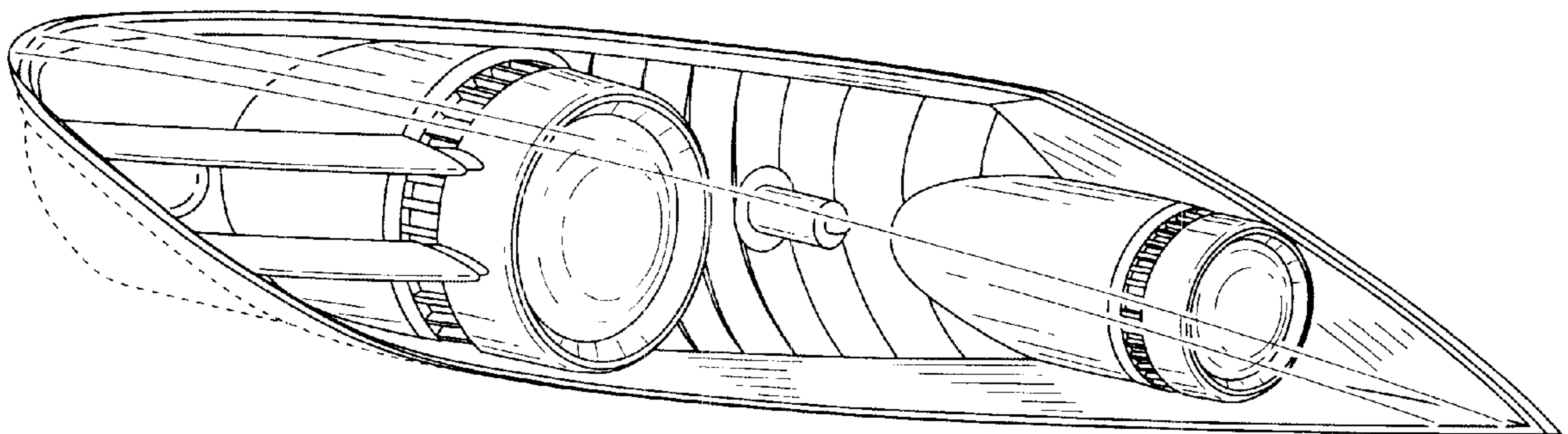

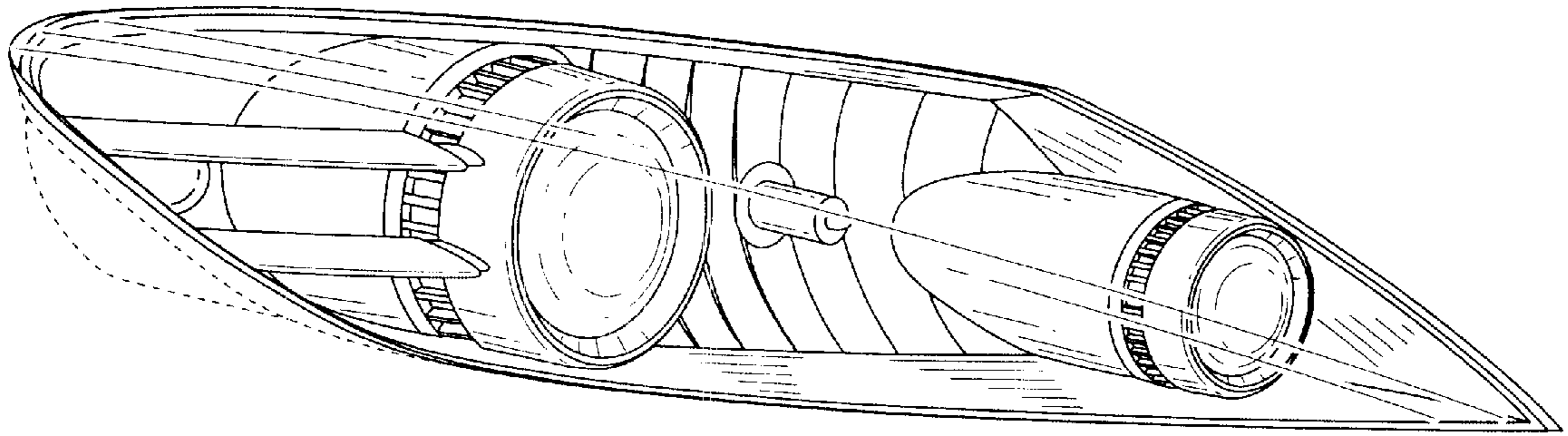

Fig. 1

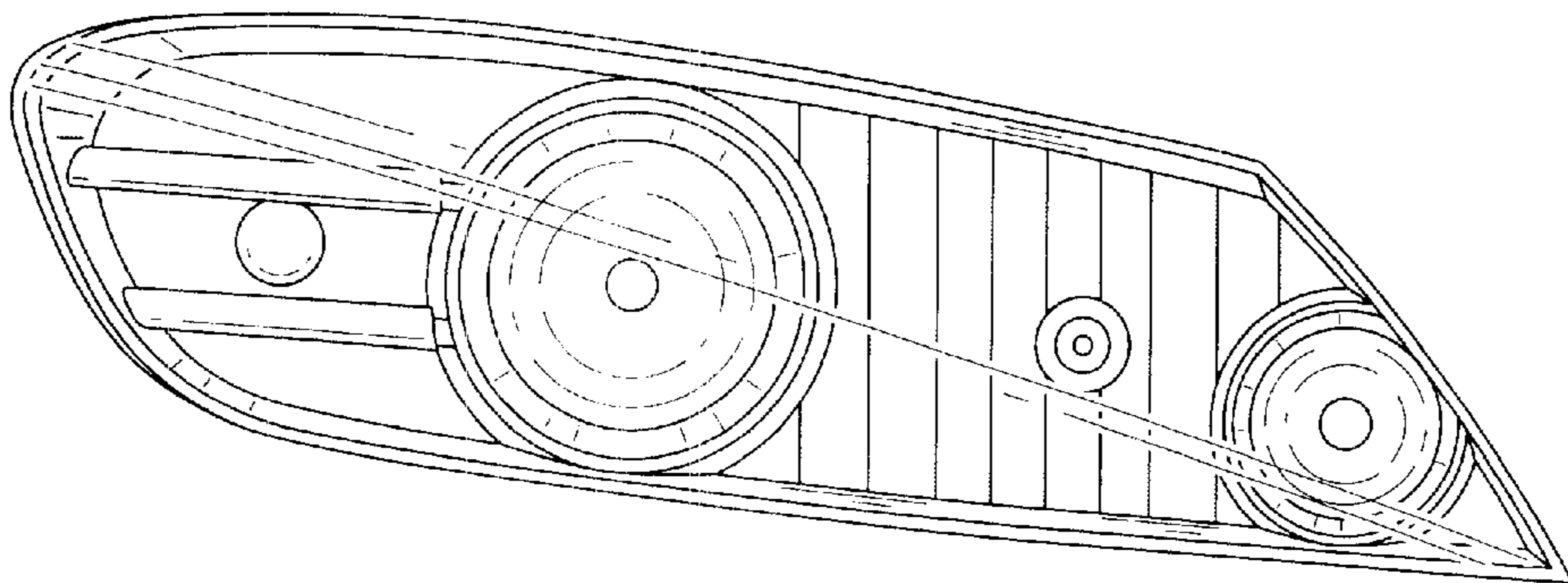

Fig. 2

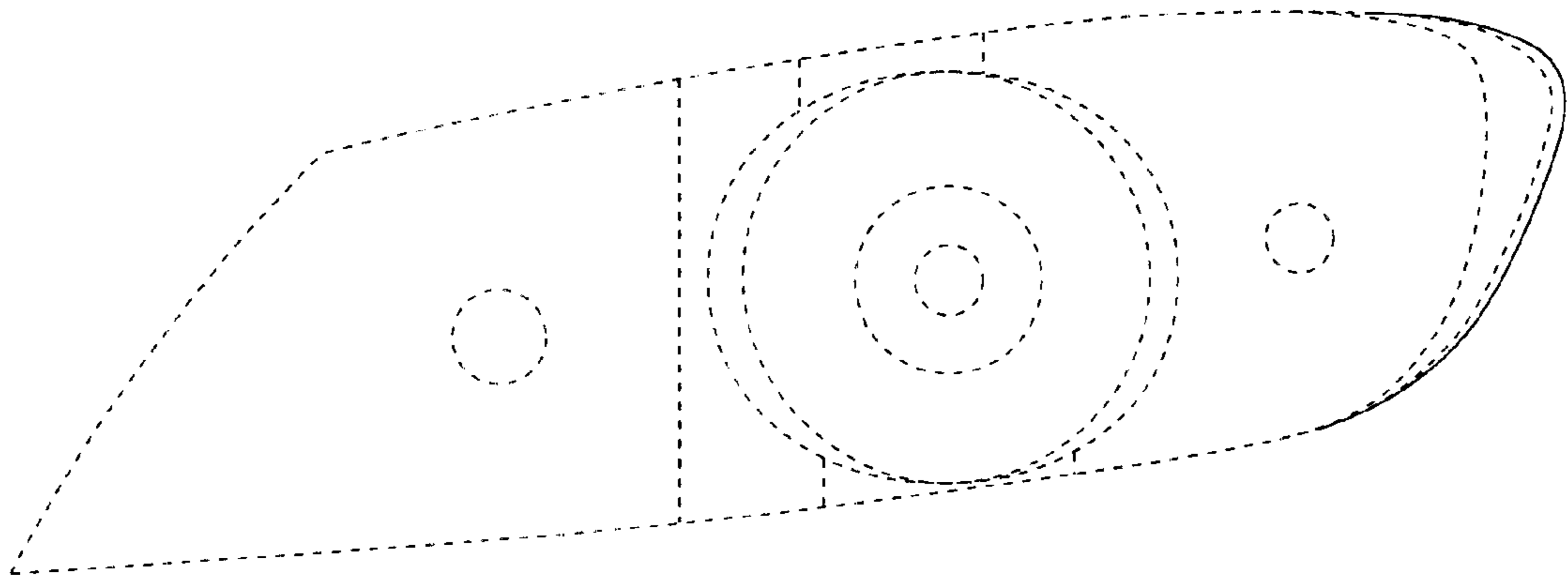

Fig. 3

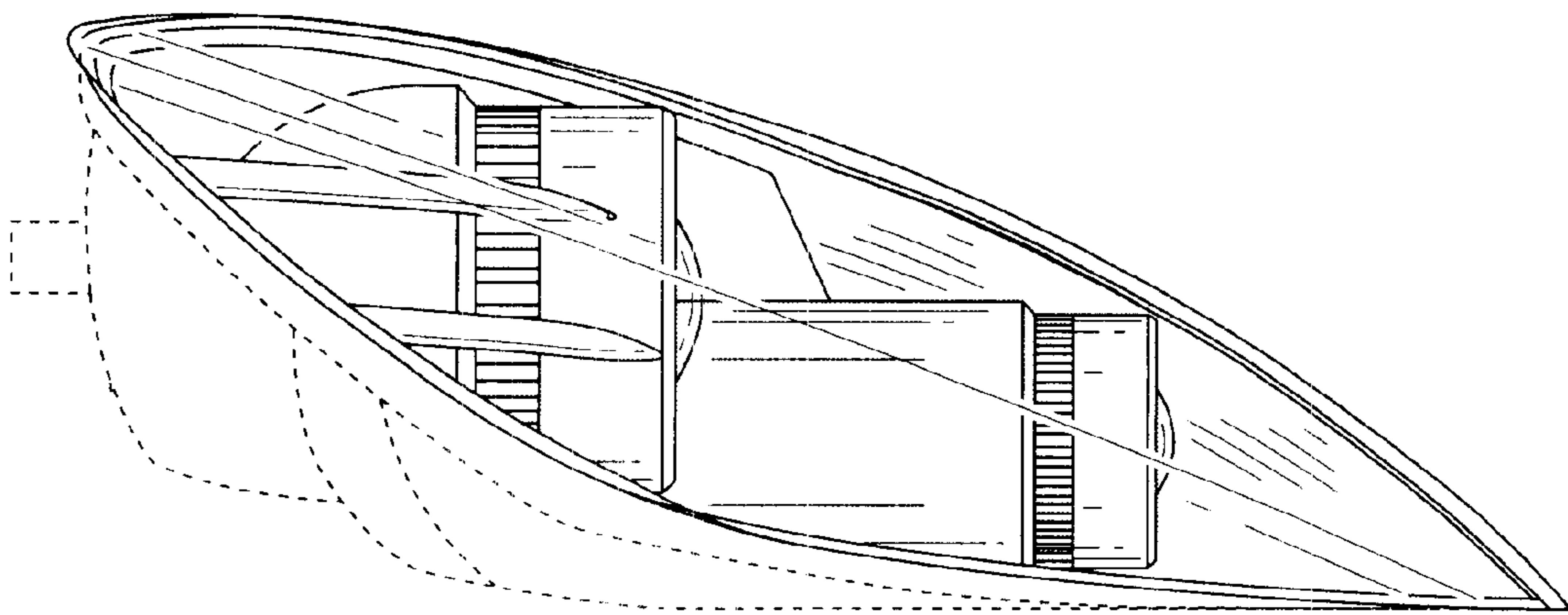

Fig. 4

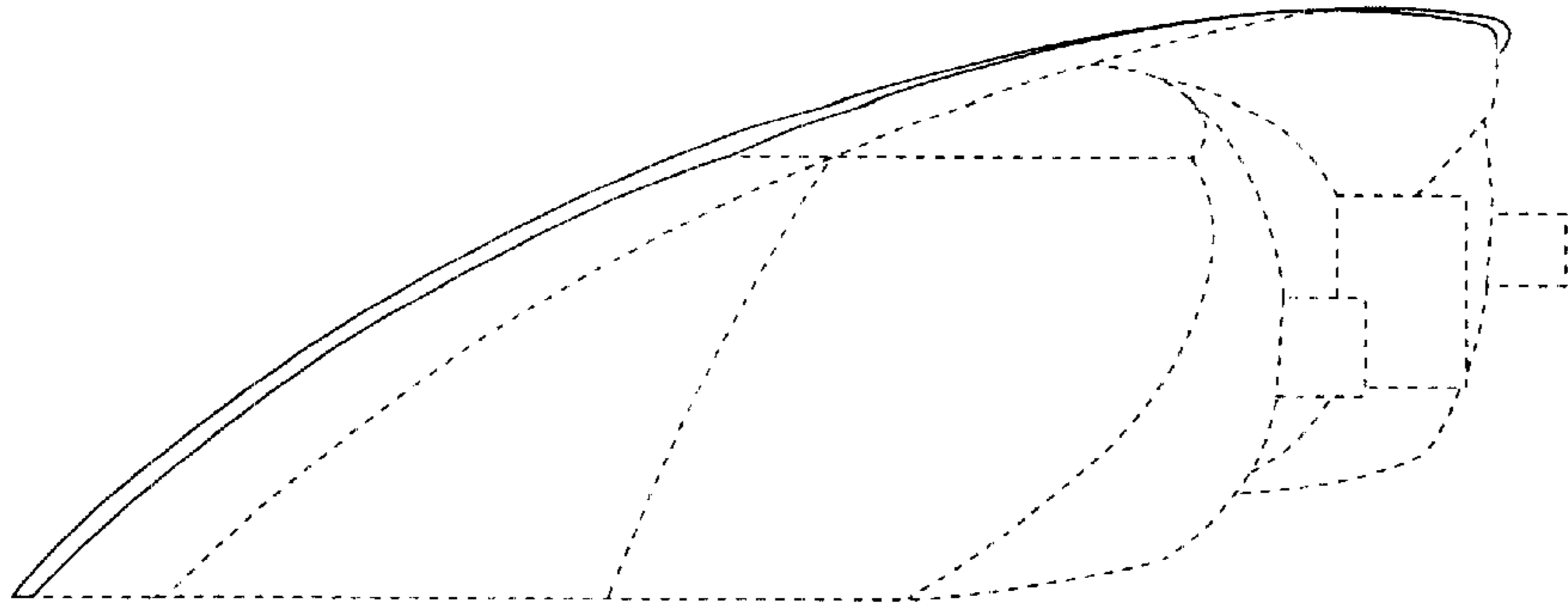

Fig. 5

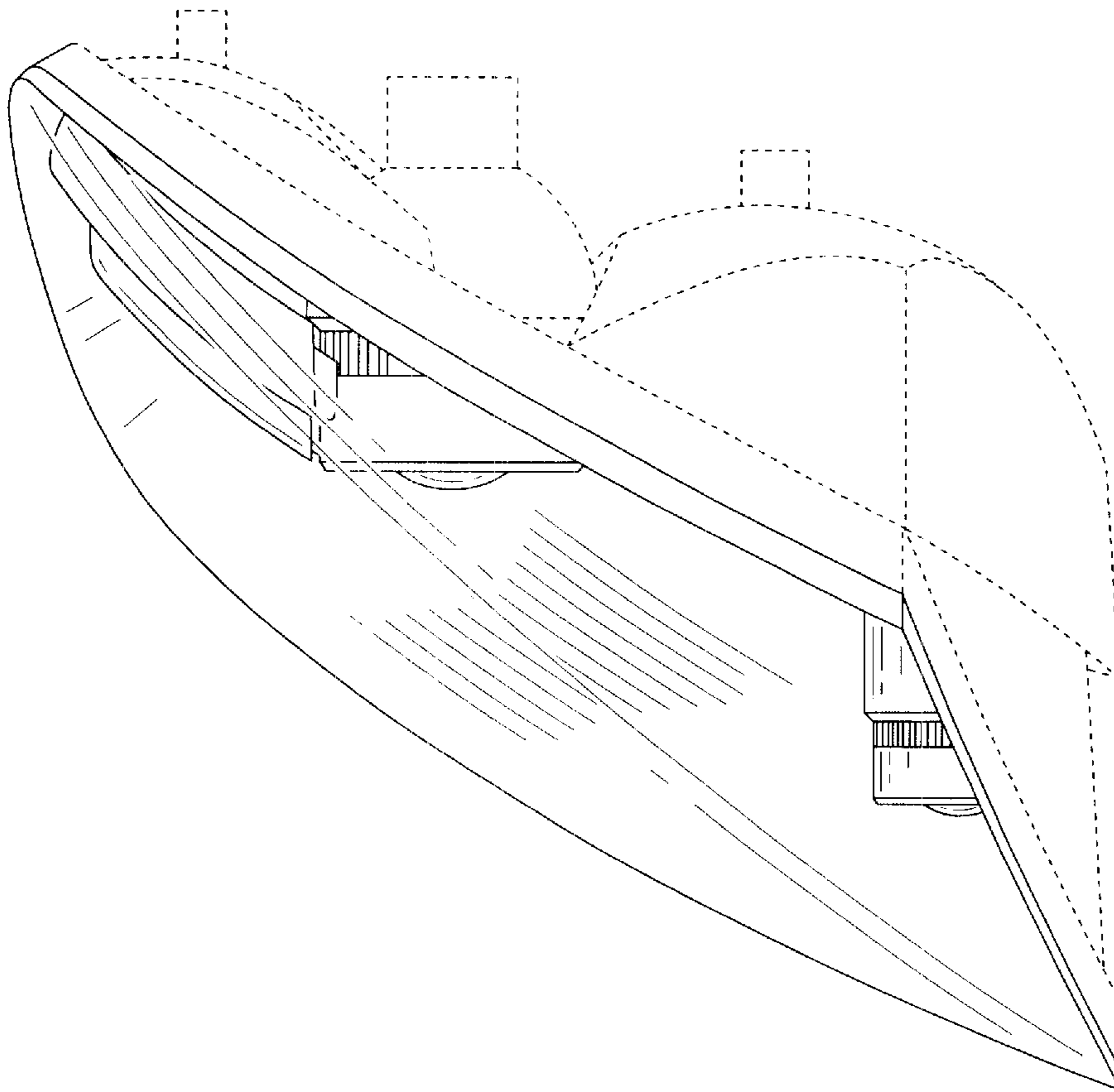

Fig. 6

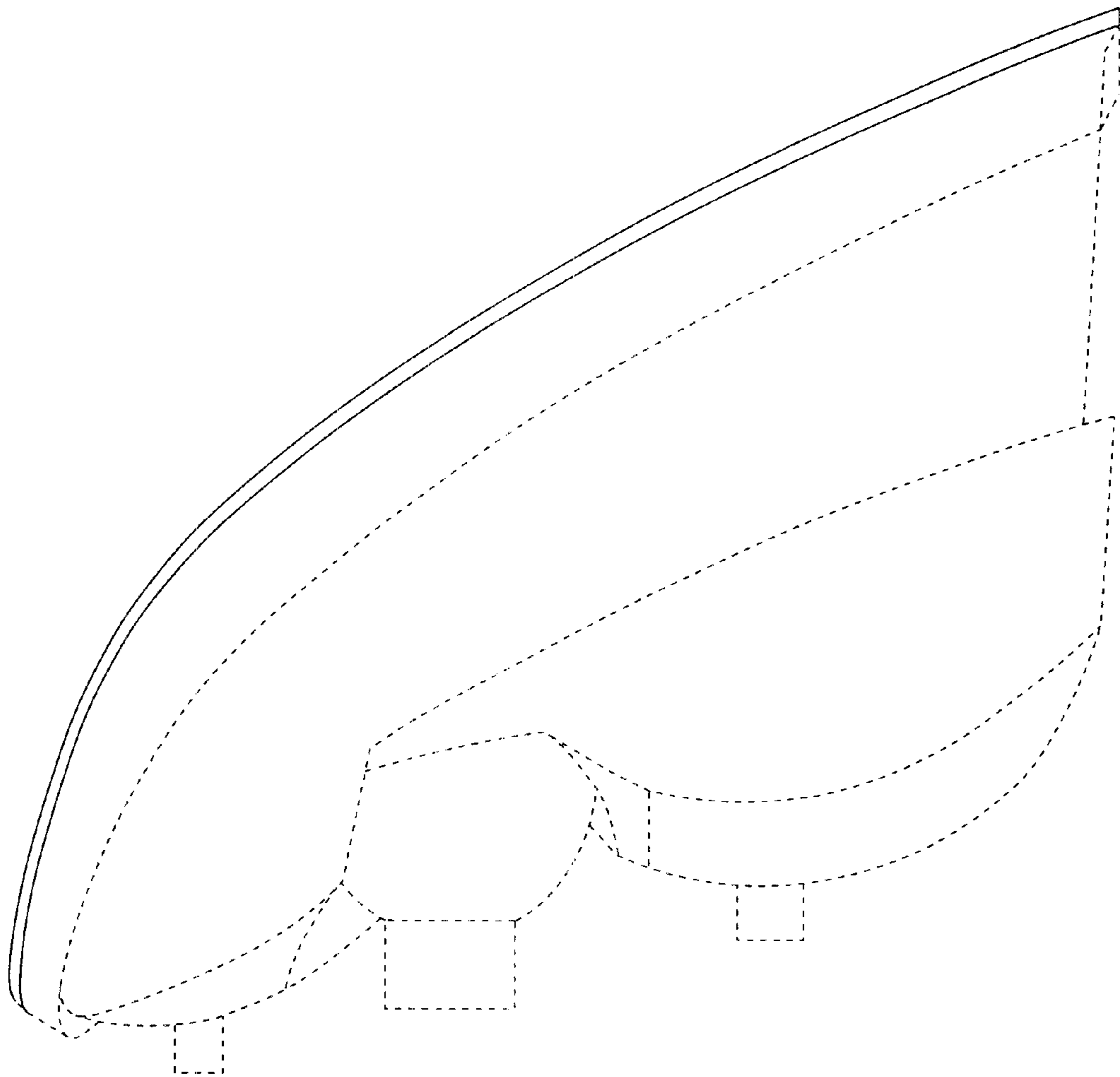

Fig. 7