



US00D470669S

(12) **United States Design Patent**
Stewart

(10) **Patent No.:** **US D470,669 S**

(45) **Date of Patent:** **** Feb. 25, 2003**

- (54) **SEAT**
- (75) **Inventor:** **Kipp Stewart, Carmel, CA (US)**
- (73) **Assignee:** **Landscape Forms, Inc., Kalamazoo, MI (US)**
- (**) **Term:** **14 Years**
- (21) **Appl. No.:** **29/167,419**
- (22) **Filed:** **Sep. 12, 2002**

D354,405 S	1/1995	Greene	D6/370
D381,536 S	7/1997	Kane	D6/500
D412,622 S	8/1999	DeJule	D6/371
D439,068 S	3/2001	Vanderbyl	D6/379
D440,422 S	4/2001	DeJule	D6/371

Primary Examiner—Caron D. Veynar
Assistant Examiner—Mimosa De
 (74) *Attorney, Agent, or Firm*—Heslin Rothenberg Farley & Mesiti P.C.

Related U.S. Application Data

- (62) Division of application No. 29/149,393, filed on Oct. 9, 2001.
- (51) **LOC (7) Cl.** **06-01**
- (52) **U.S. Cl.** **D6/370**
- (58) **Field of Search** D6/334, 335, 370, D6/371, 373, 374, 375, 376, 379, 380, 381, 500-502; 297/232, 248, 452.12, 452.18, 452.19, 452.2, 452.63, 411.2

References Cited

U.S. PATENT DOCUMENTS

3,511,536 A	5/1970	Suzuki	297/452.63
D249,413 S	9/1978	Frank	D6/371
D263,353 S	3/1982	Beals	D6/370
D323,249 S	1/1992	Schwartz	D6/370
D331,518 S	12/1992	Grosfillex	D6/381
D337,001 S	7/1993	Grosfillex	D6/379
D338,115 S	8/1993	Grosfillex	D6/370
D344,200 S	2/1994	Schwartz	D6/500

(57) **CLAIM**

The ornamental design for a seat, as shown and described.

DESCRIPTION

FIG. 1 is an isometric view of a first embodiment of the seat; FIG. 2 is a top plan view thereof; FIG. 3 is a front elevational view thereof; FIG. 4 is a back elevational view thereof; FIG. 5 is a left side elevational view thereof, the right side elevational view being a mirror image thereof; FIG. 6 is an isometric view of a second embodiment of the seat, the only difference from the first embodiment being the addition of a second seat section and a filler strip; FIG. 7 is a back elevational view of the second embodiment; and, FIG. 8 is an isometric view of a third embodiment of the seat, the only difference from the second embodiment being the addition of a third seat section and another filler strip. The broken line showing in the drawing figures is for illustrative purposes only and forms no part of the claimed design.

1 Claim, 5 Drawing Sheets

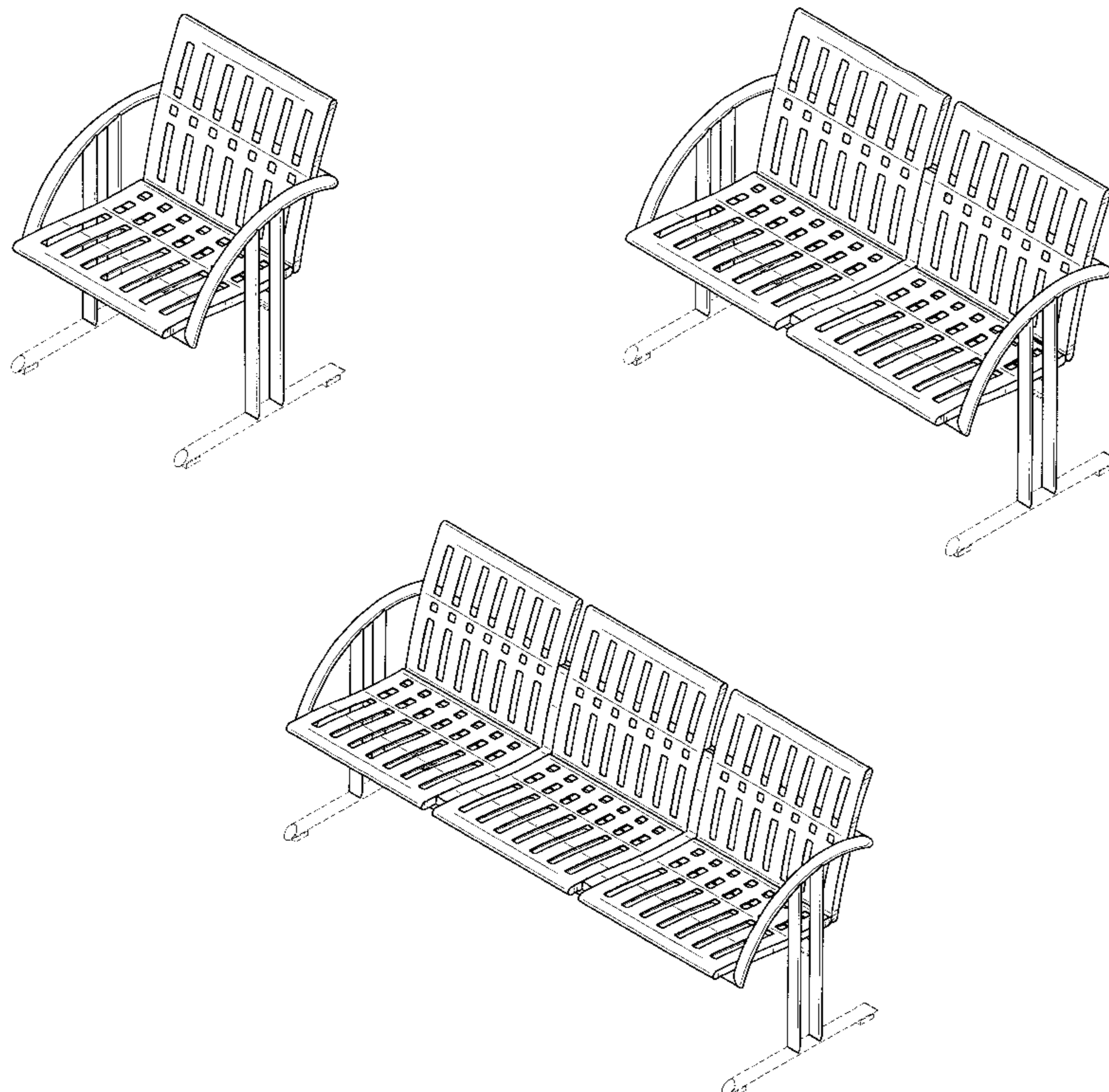

FIG. 1

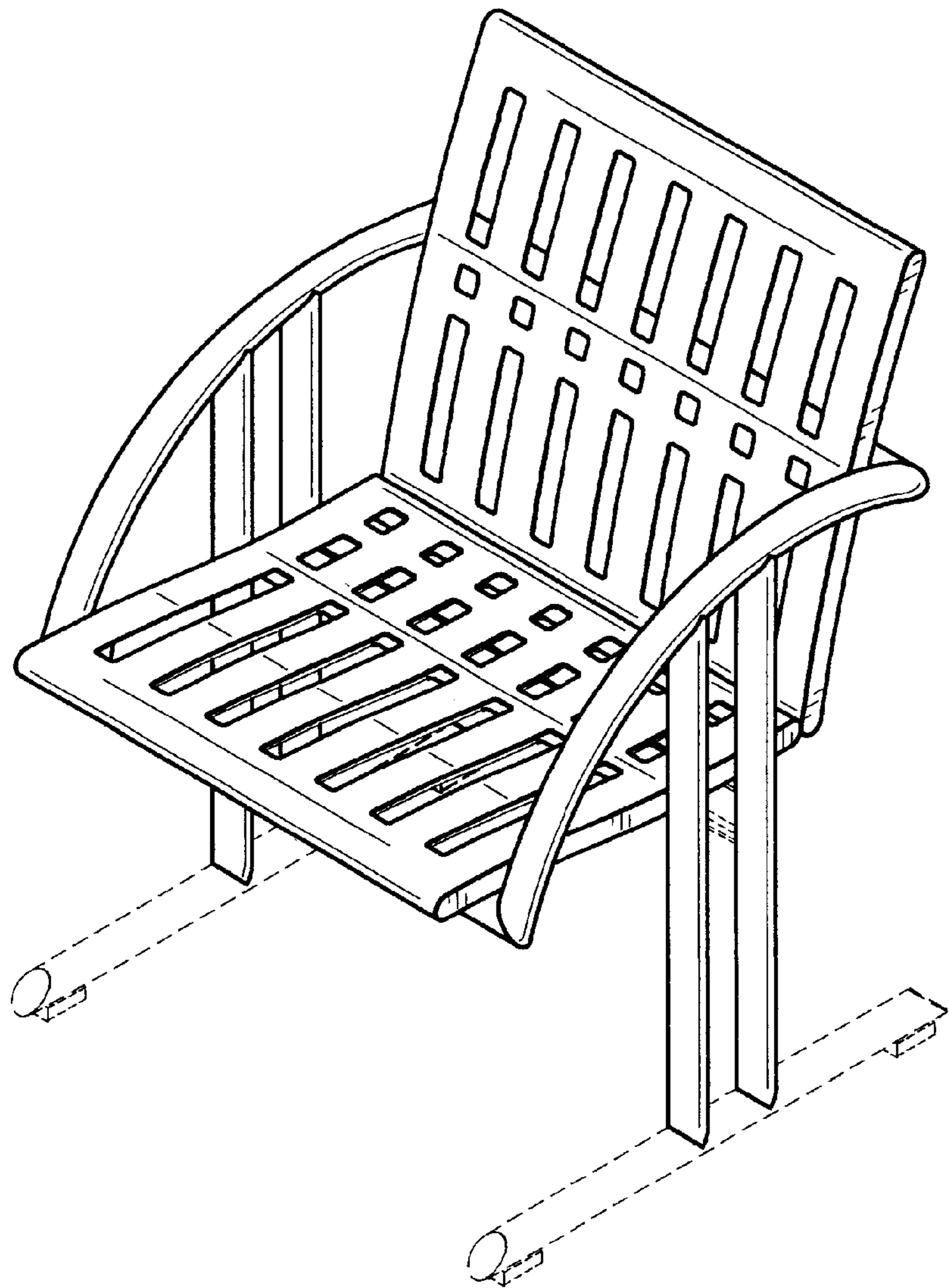

FIG. 2

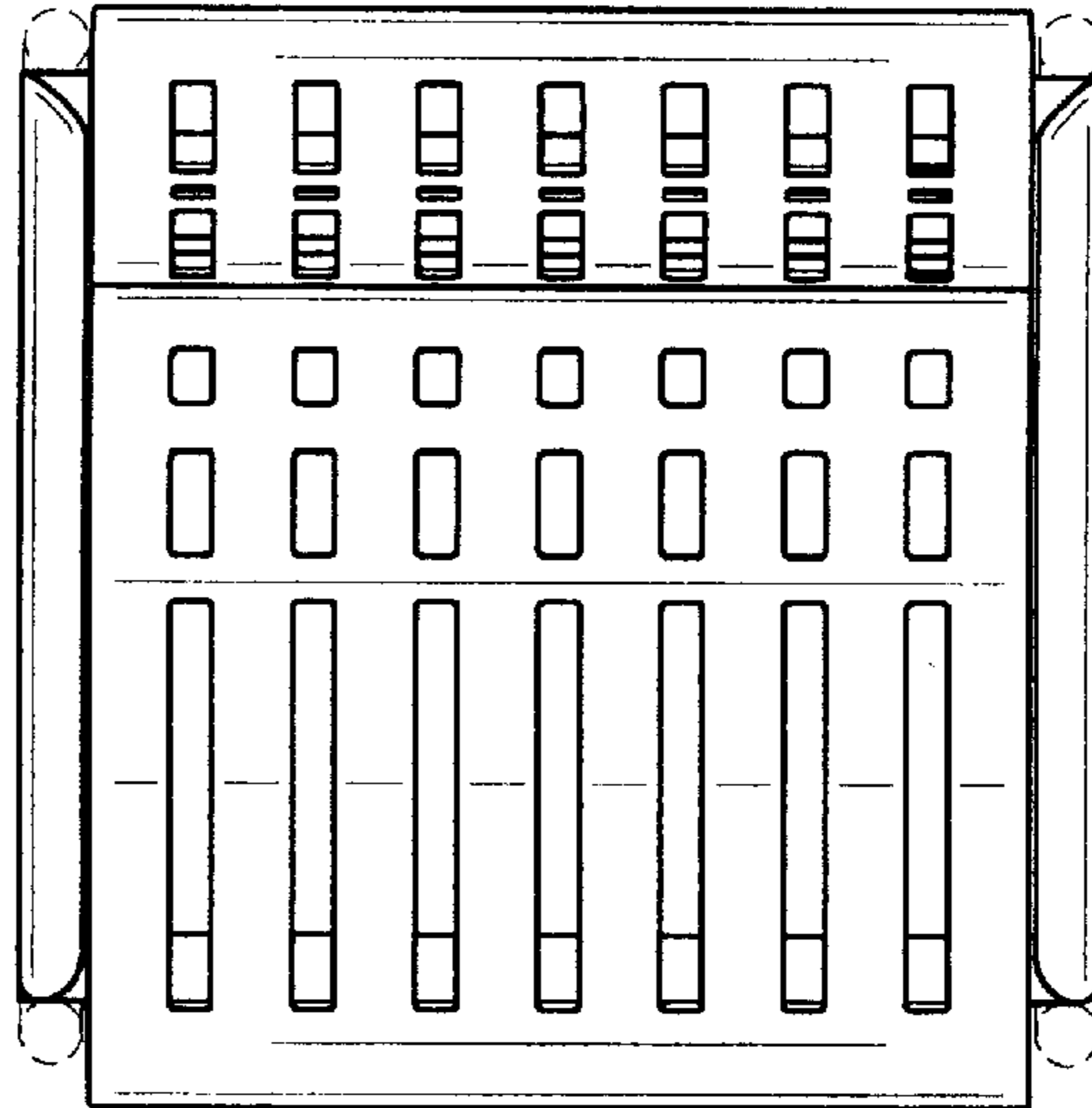

FIG. 3

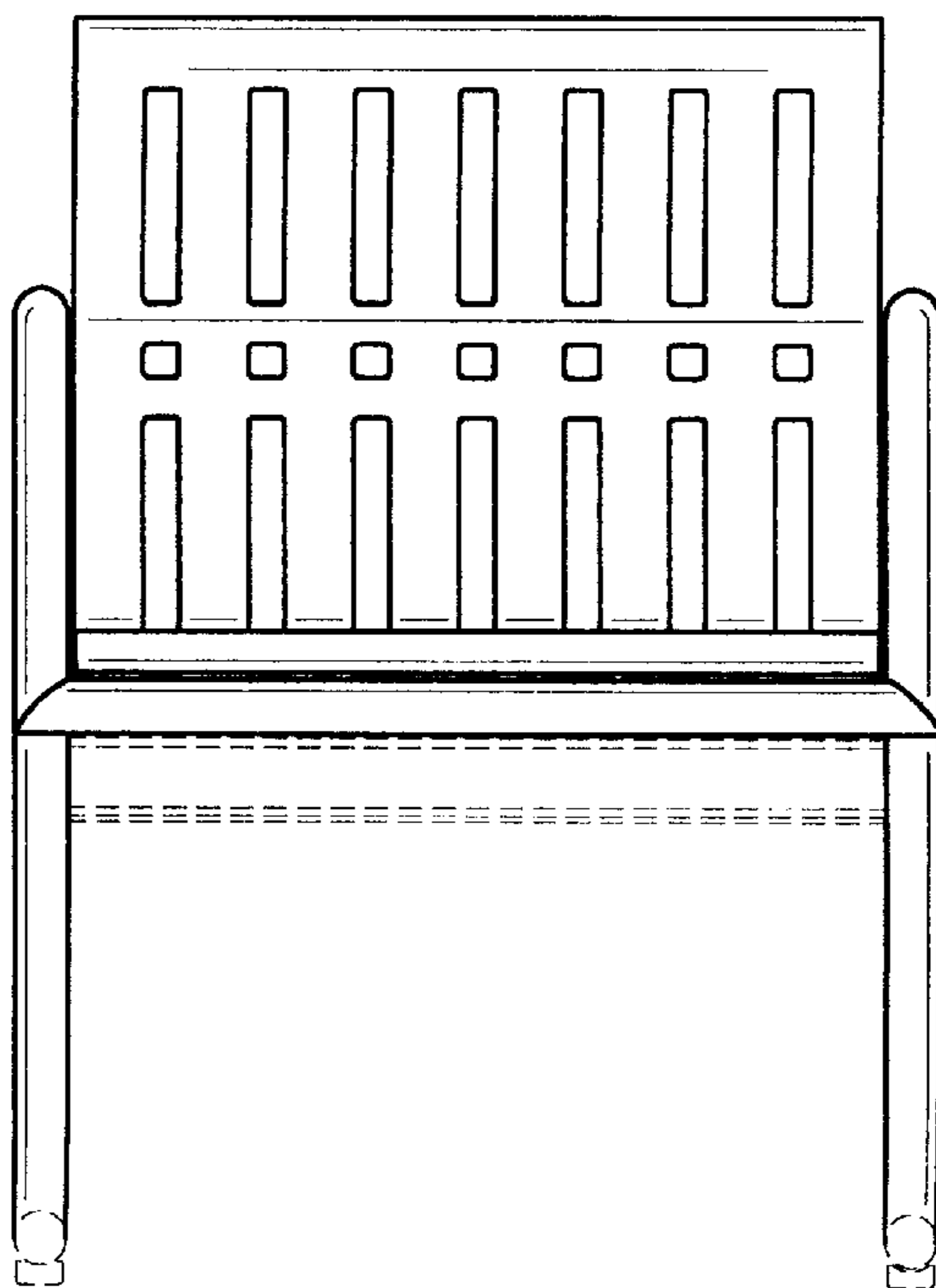

FIG. 4

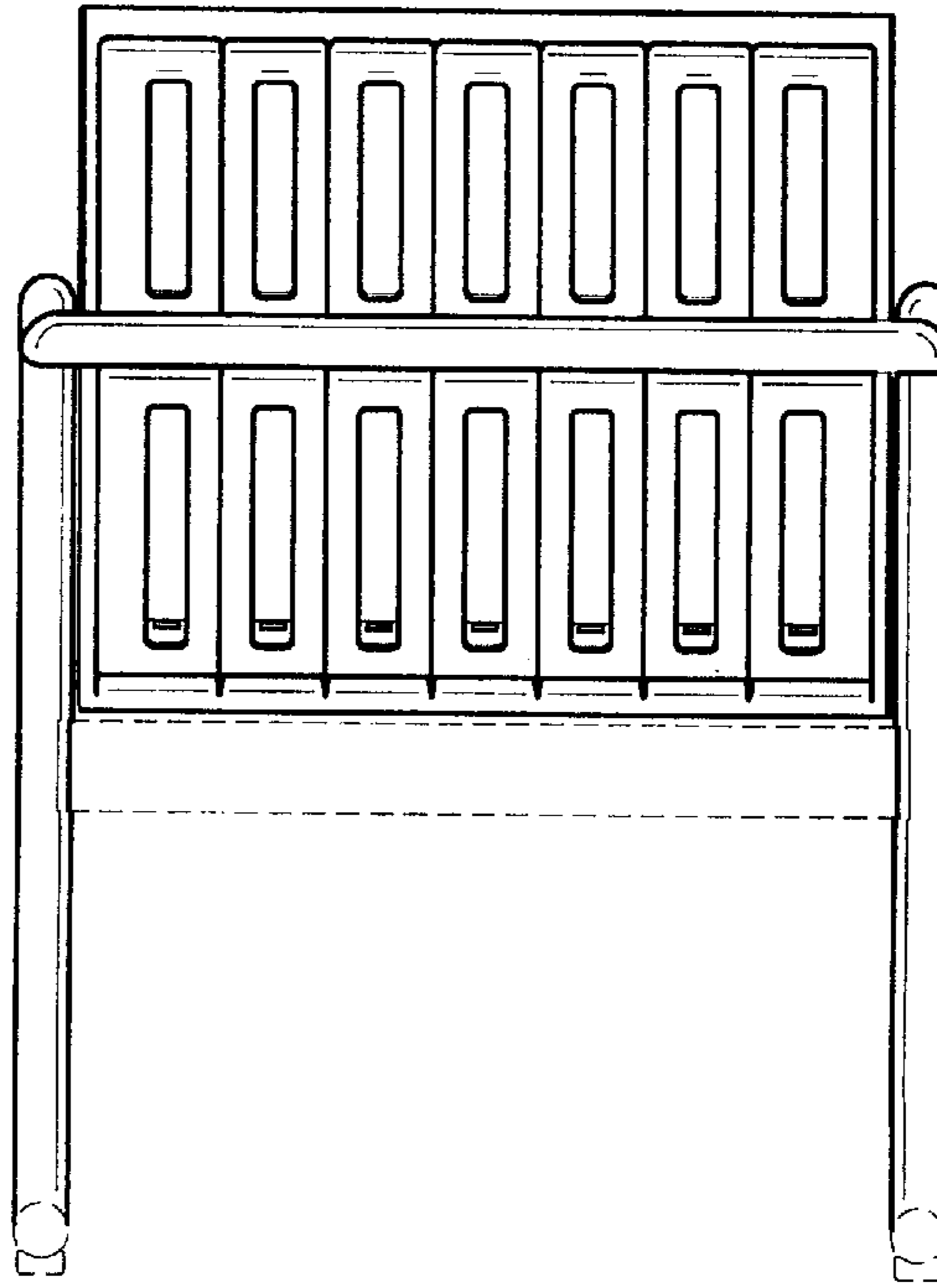

FIG. 5

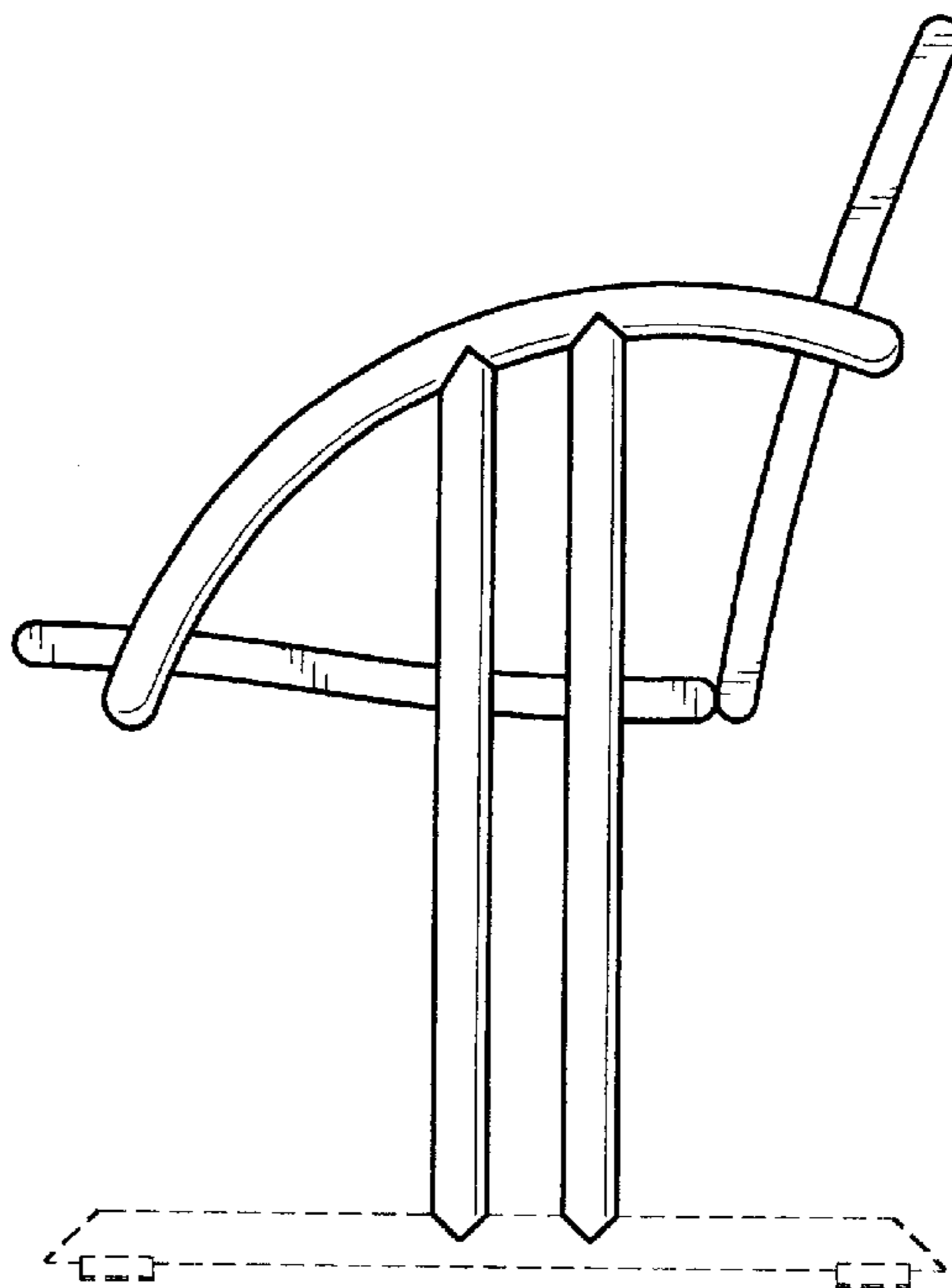

FIG. 6

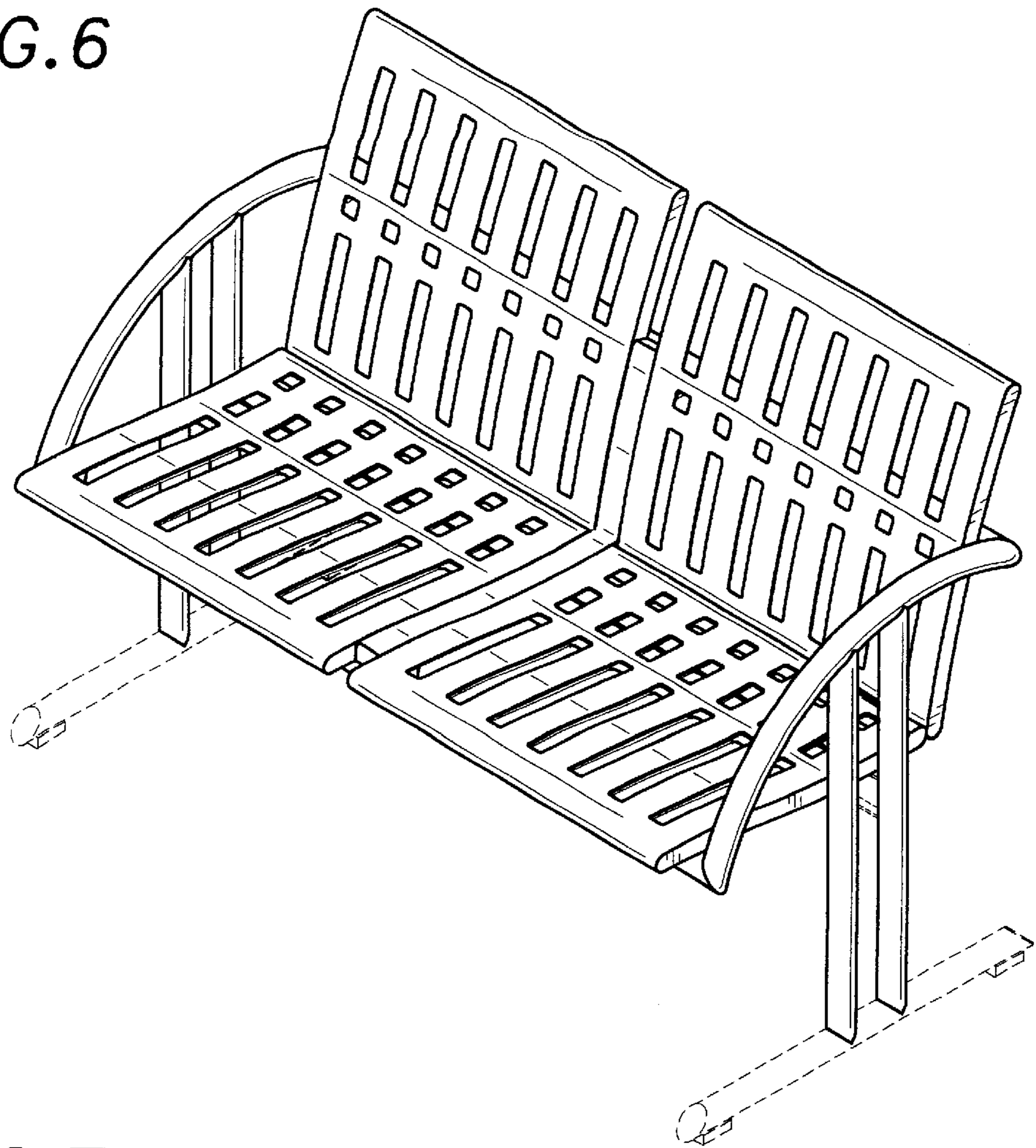
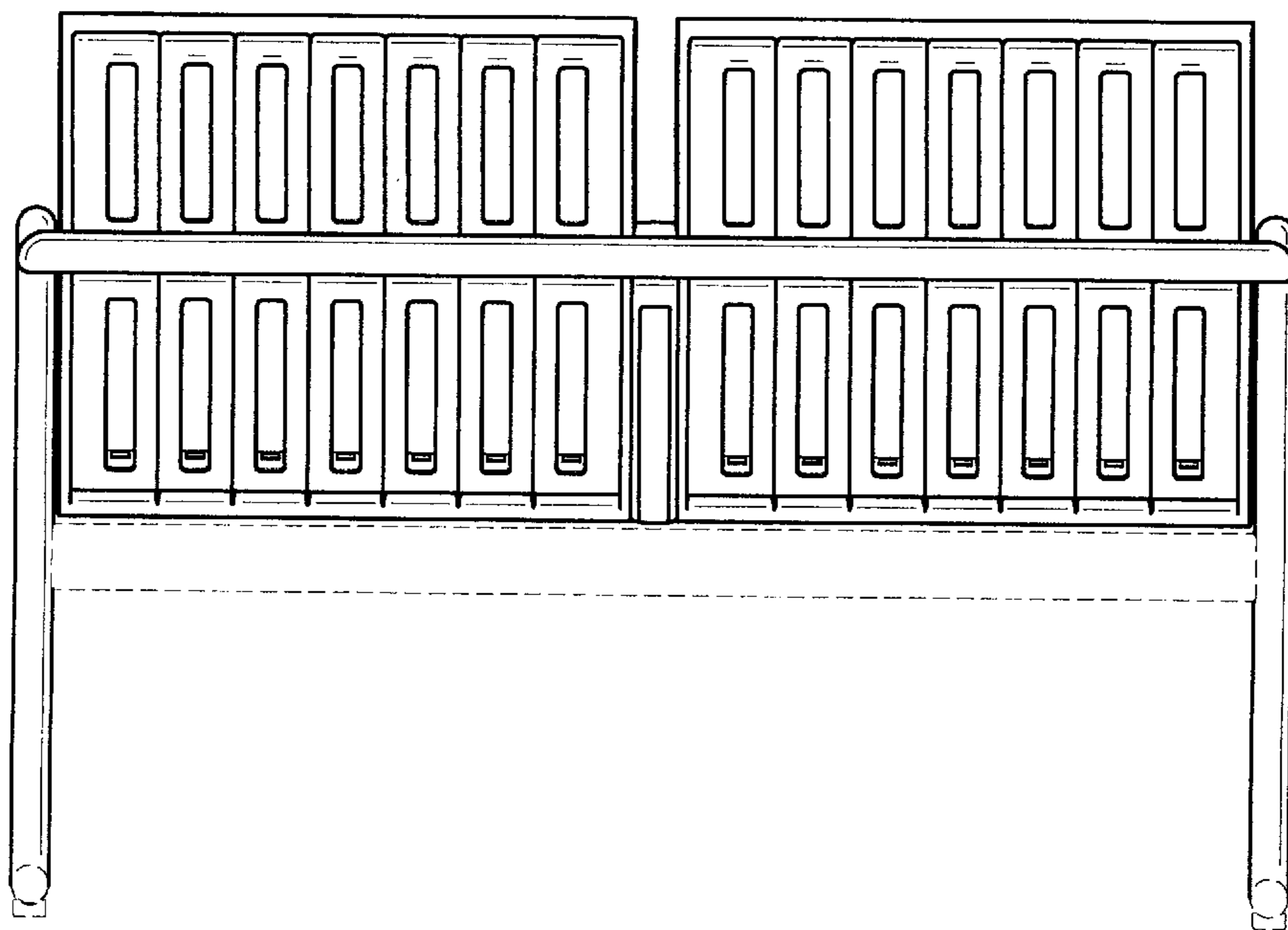

FIG. 7



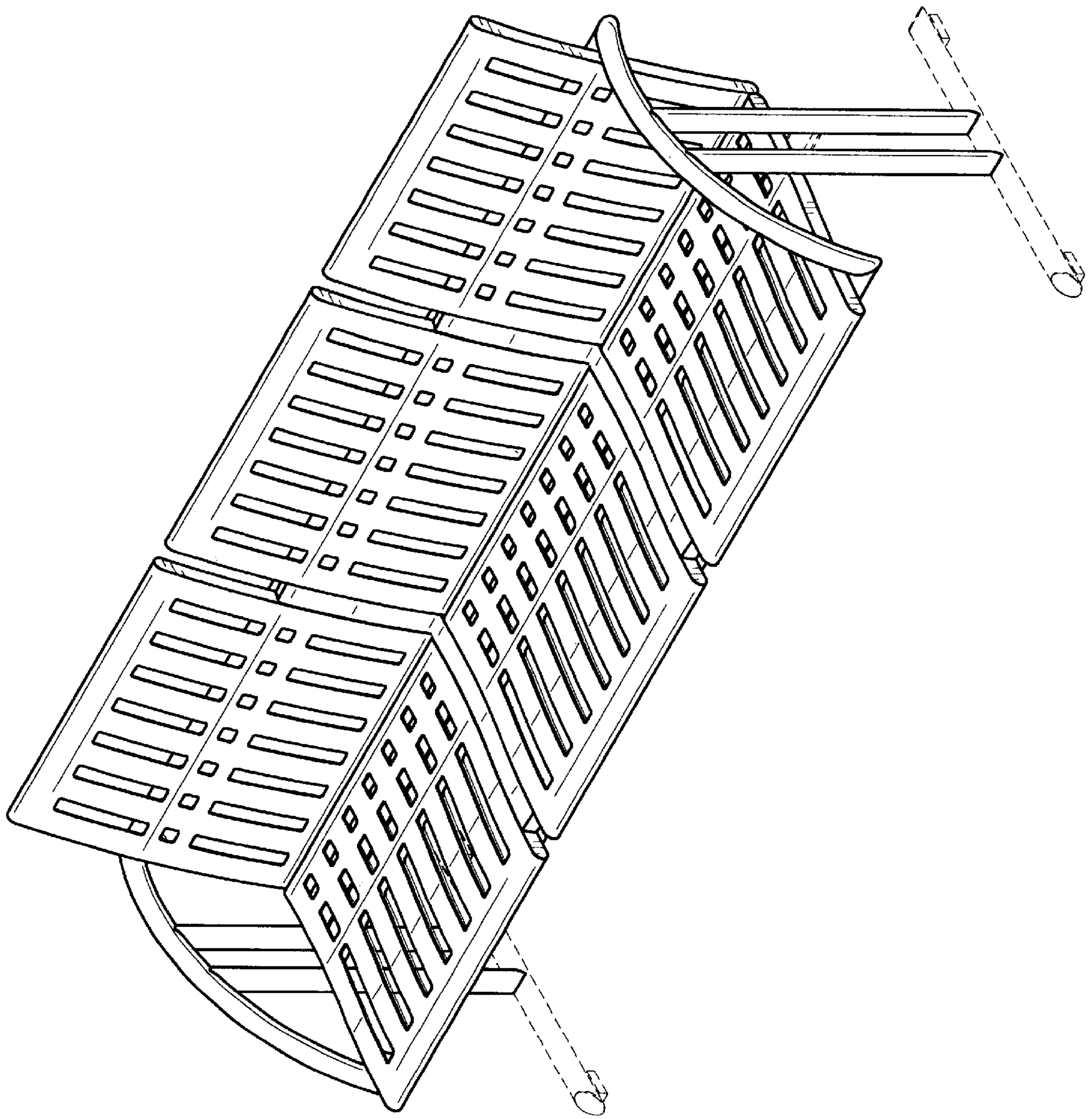

FIG. 8