



US00D470571S

(12) **United States Design Patent**  
**Pitsch**

(10) **Patent No.:** **US D470,571 S**

(45) **Date of Patent:** **\*\* Feb. 18, 2003**

(54) **FAUCET BODY**

(75) Inventor: **Walter Pitsch**, Franklin Park, NJ (US)

(73) Assignee: **American Standard Inc.**, Piscataway, NJ (US)

(\*\*) Term: **14 Years**

(21) Appl. No.: **29/079,814**

(22) Filed: **Nov. 19, 1997**

(51) **LOC (7) Cl.** ..... **23-01**

(52) **U.S. Cl.** ..... **D23/238**

(58) **Field of Search** ..... **D23/238-243,**  
**D23/250-257, 675-678; 137/801**

5,368,071 A	11/1994	Hsieh	
D365,142 S	12/1995	Hill et al.	
D369,208 S	4/1996	Doughty et al.	
D373,616 S	9/1996	Doughty et al.	
D373,618 S	9/1996	Doughty et al.	
D373,621 S	9/1996	Doughty et al.	
D374,706 S	10/1996	Doughty et al.	
D381,066 S	7/1997	Hill et al.	
5,642,755 A	7/1997	Mark et al.	
D382,940 S	8/1997	Ku	
D388,863 S	* 1/1998	Kolada	..... D23/238
D407,798 S	* 4/1999	Pitsch	..... D23/241
D421,484 S	* 3/2000	Pitsch	..... D23/238

**FOREIGN PATENT DOCUMENTS**

EP 485346 10/1991

**OTHER PUBLICATIONS**

Delta-Delex Faucets Catalog—1976.  
*Domestic Engineering*—Kitchen and Bath—1989.

\* cited by examiner

*Primary Examiner*—Louis S. Zarfes  
*Assistant Examiner*—Gregory Andoll

(57) **CLAIM**

The ornamental design for a faucet body, as shown and described.

**DESCRIPTION**

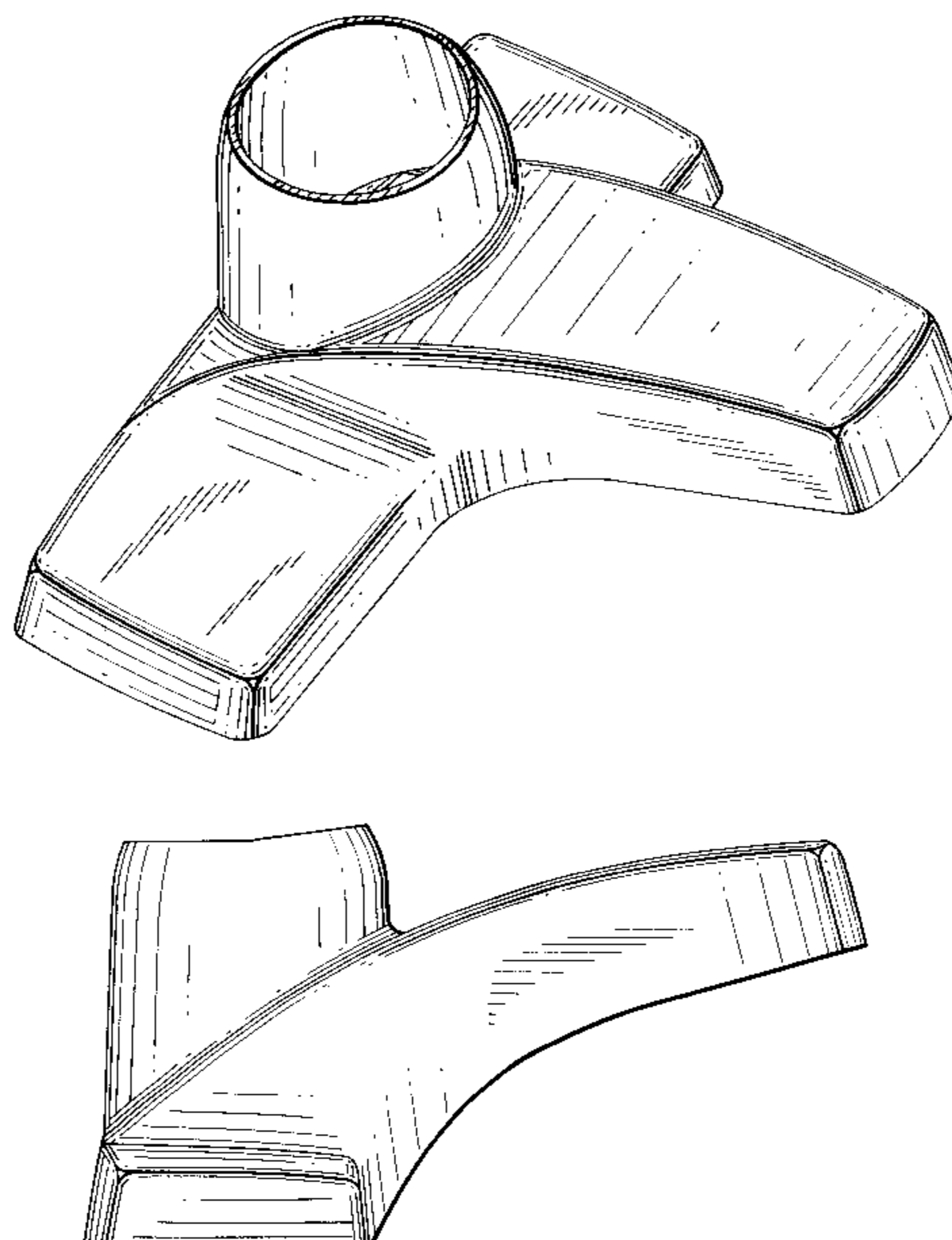
FIG. 1 is a top, front and left side perspective view of a faucet body showing my new design;  
FIG. 2 is a top plan view thereof;  
FIG. 3 is a right side elevational view thereof;  
FIG. 4 is a left side elevational view thereof;  
FIG. 5 is a front elevational view thereof;  
FIG. 6 is a back elevational view thereof; and,  
FIG. 7 is a bottom plan view thereof.

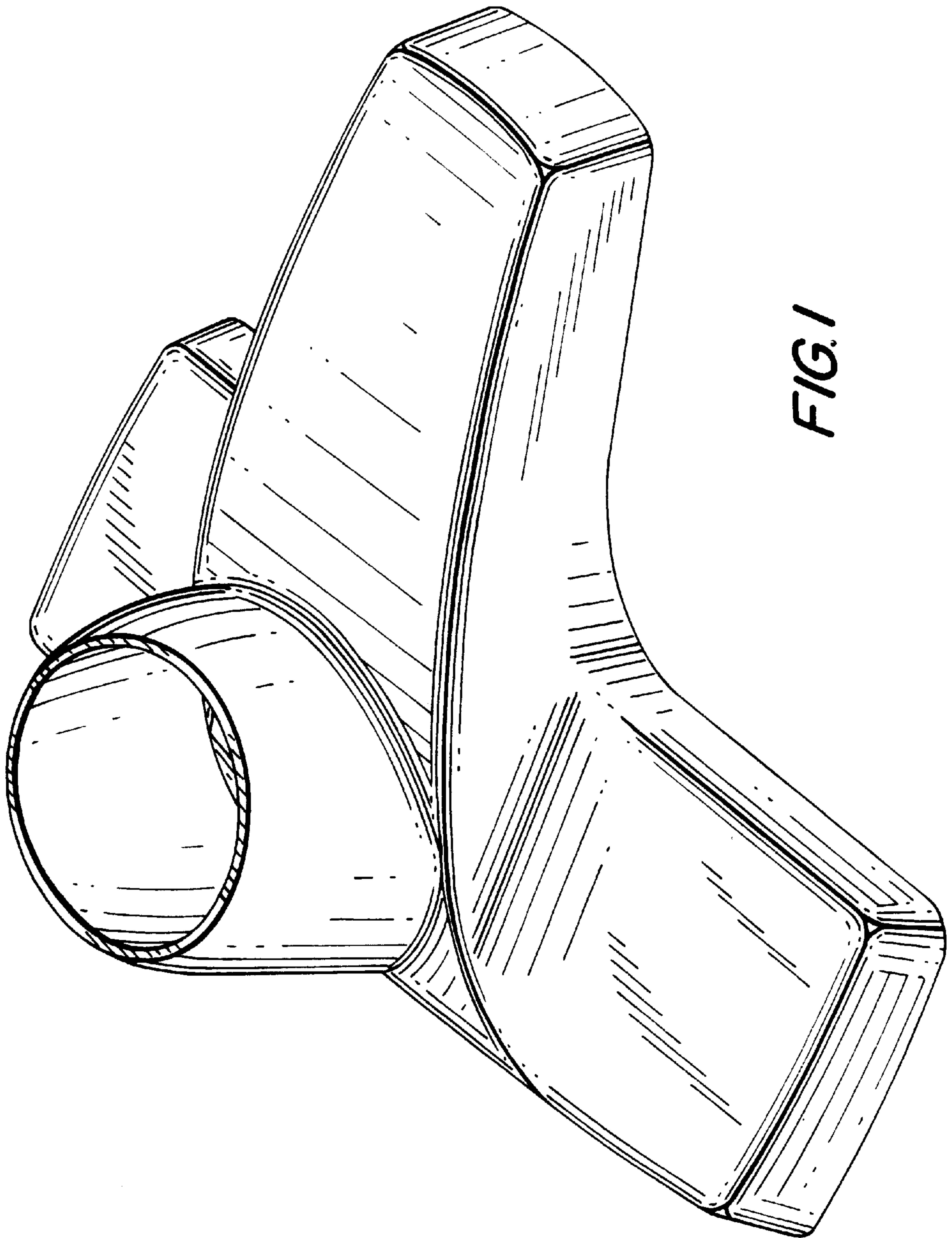
**1 Claim, 4 Drawing Sheets**

(56) **References Cited**

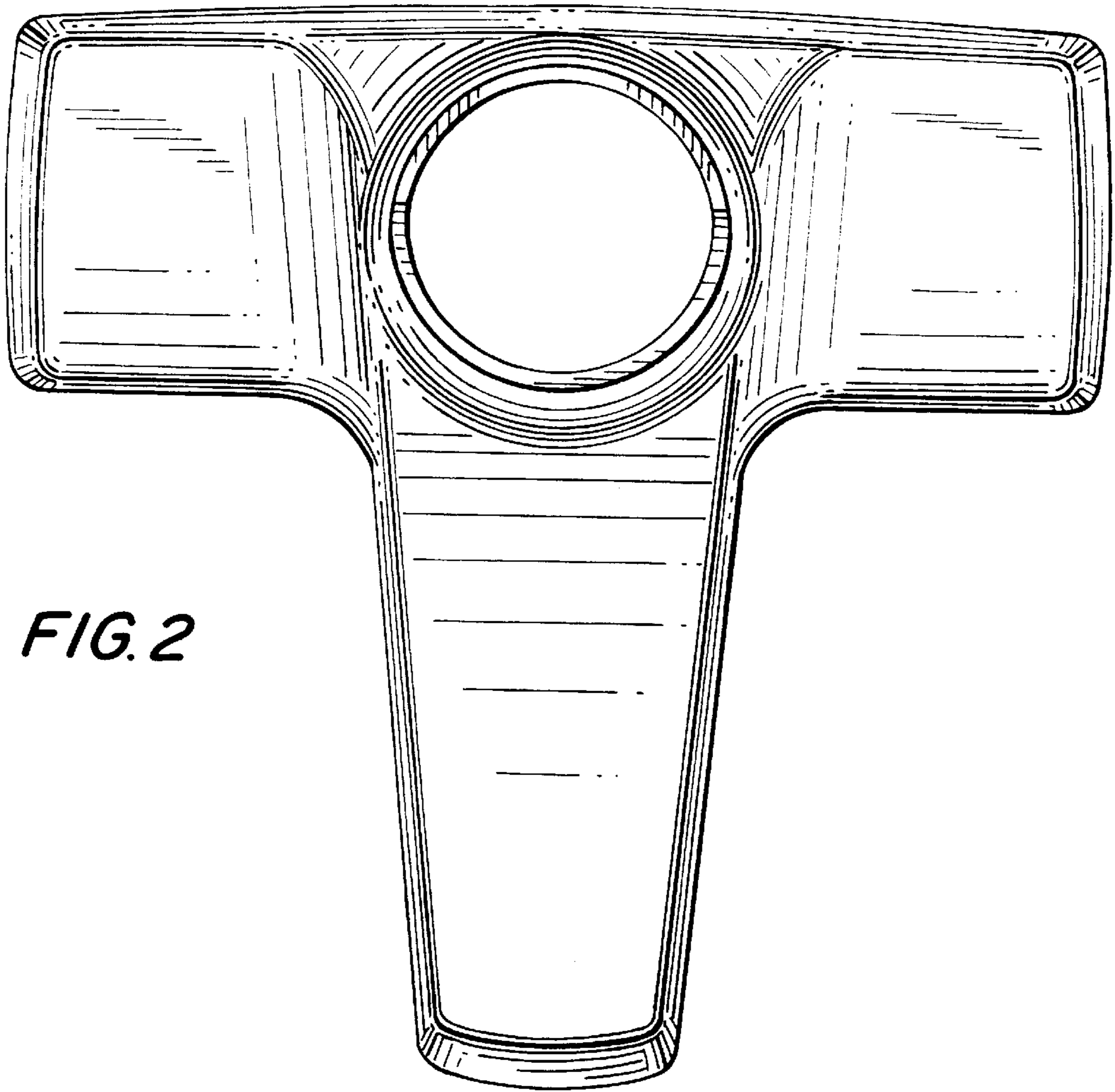
**U.S. PATENT DOCUMENTS**

D169,551 S	5/1953	Kendrick
D187,846 S	5/1960	Brown
3,035,612 A	5/1962	Lyon
3,533,436 A	10/1970	Parkinson
D250,272 S	11/1978	Jones
4,290,445 A	9/1981	Turner
4,356,574 A	11/1982	Johnson
4,387,738 A	6/1983	Bisonaya et al.
4,513,769 A	4/1985	Purcell
4,649,958 A	3/1987	Purcell
4,700,928 A	10/1987	Marty
4,747,428 A	5/1988	Crawford et al.
4,751,943 A	6/1988	Chi
D299,518 S	1/1989	Yost
5,031,657 A	7/1991	Stairs
D323,877 S	2/1992	Haug et al.
D325,423 S	4/1992	Kolada et al.
5,131,428 A	7/1992	Bory
D329,685 S	9/1992	Brattoli et al.
5,165,121 A	11/1992	McTargett et al.
D346,852 S	5/1994	Hill

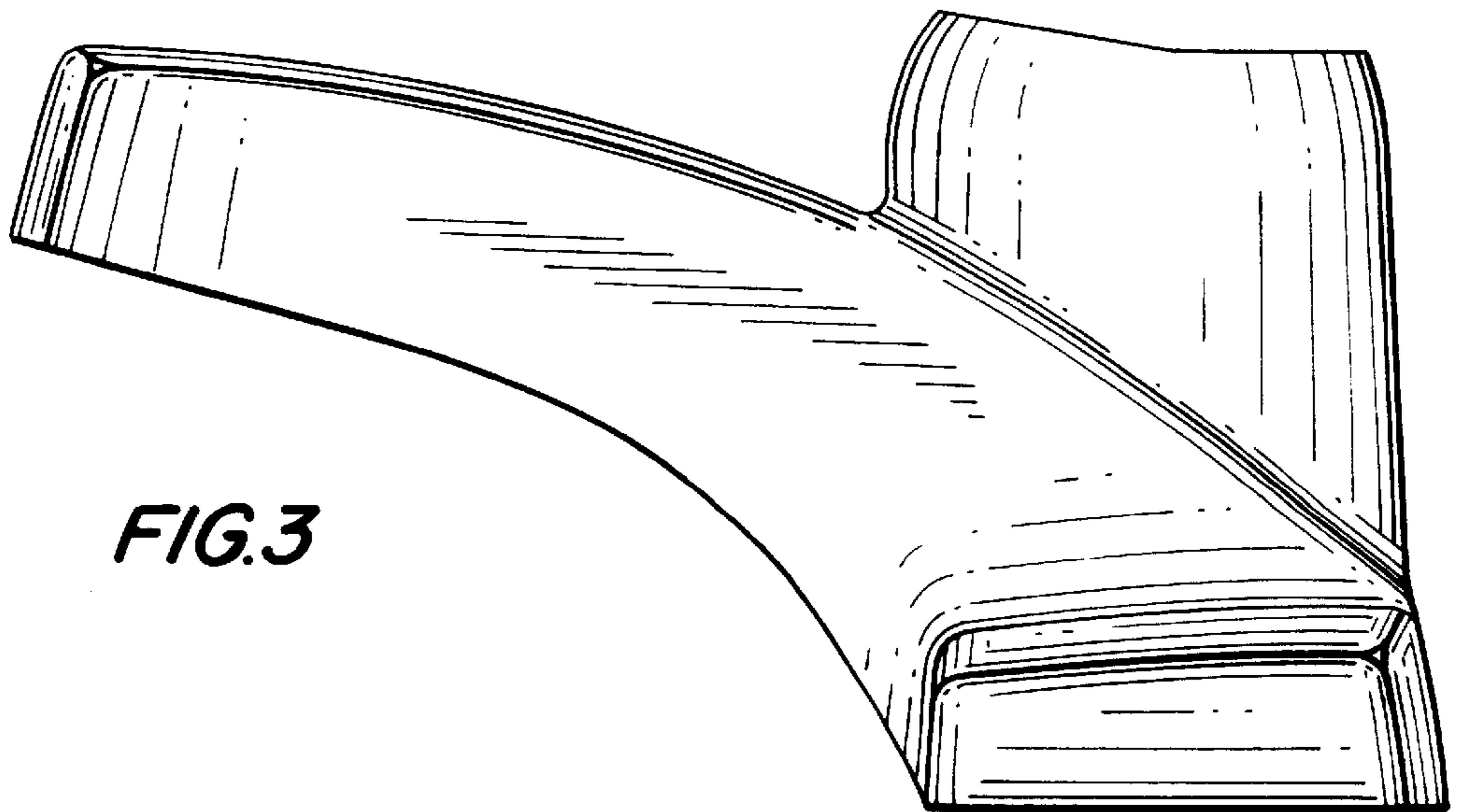




*FIG. 1*



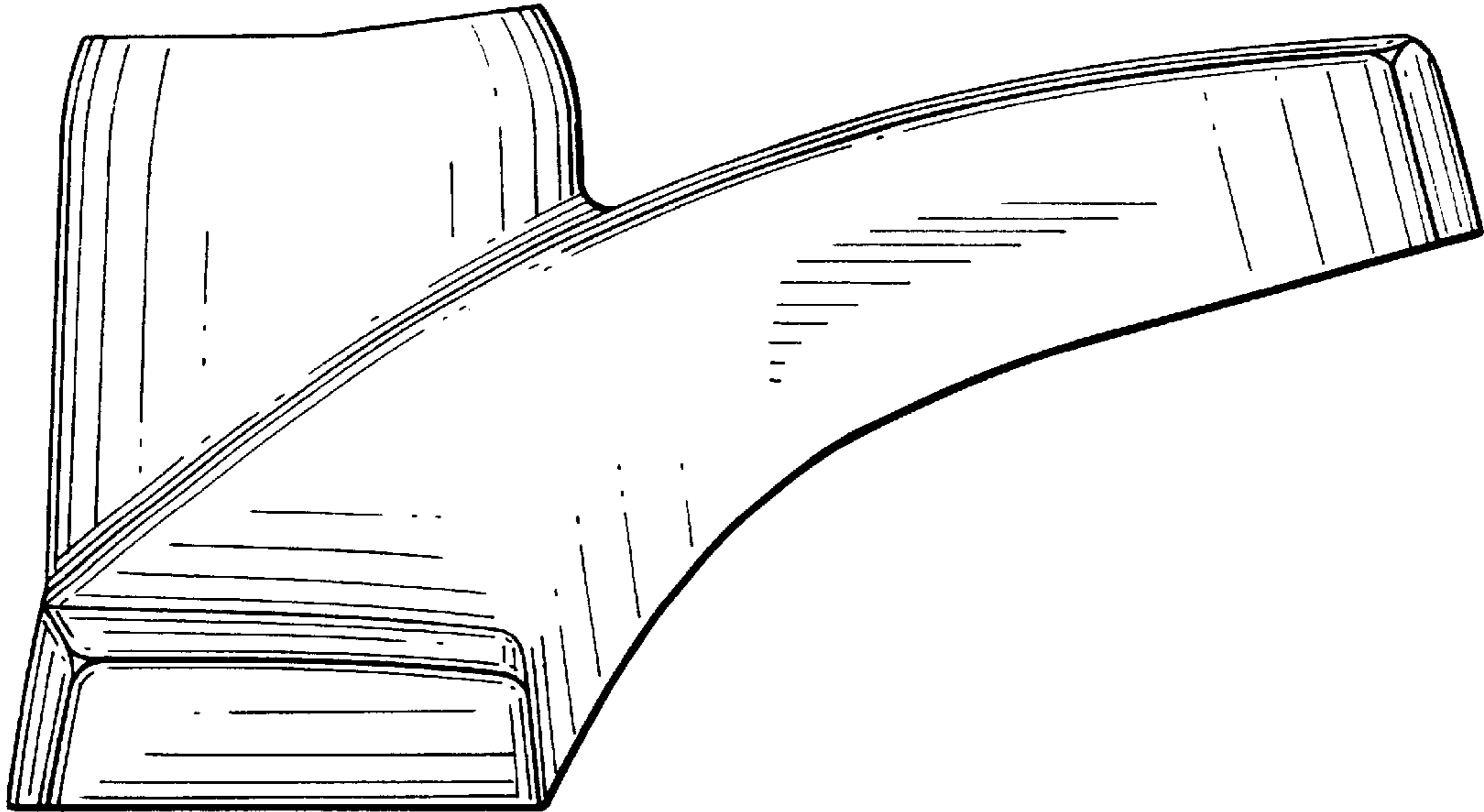
*FIG. 2*



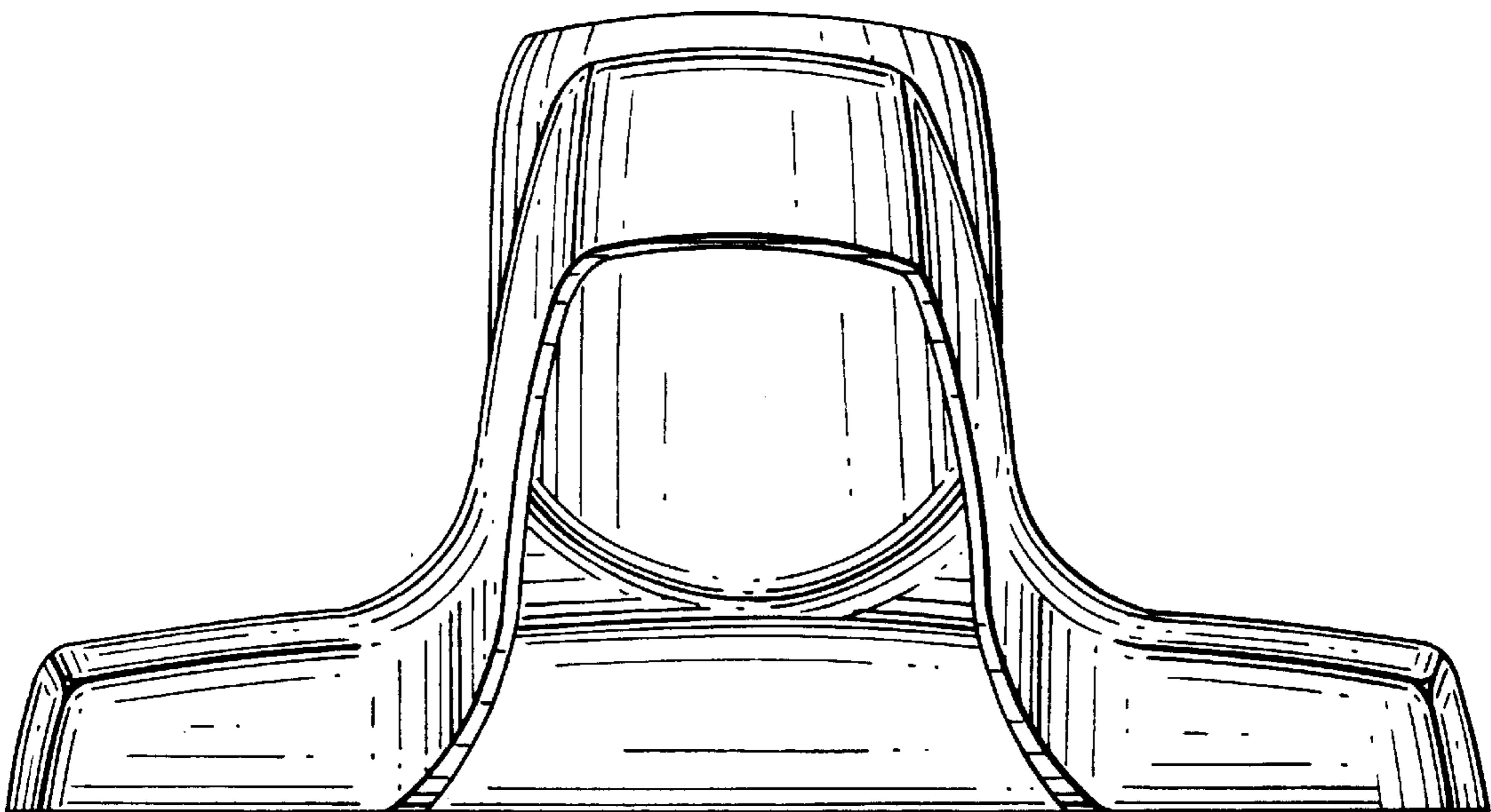
*FIG. 3*



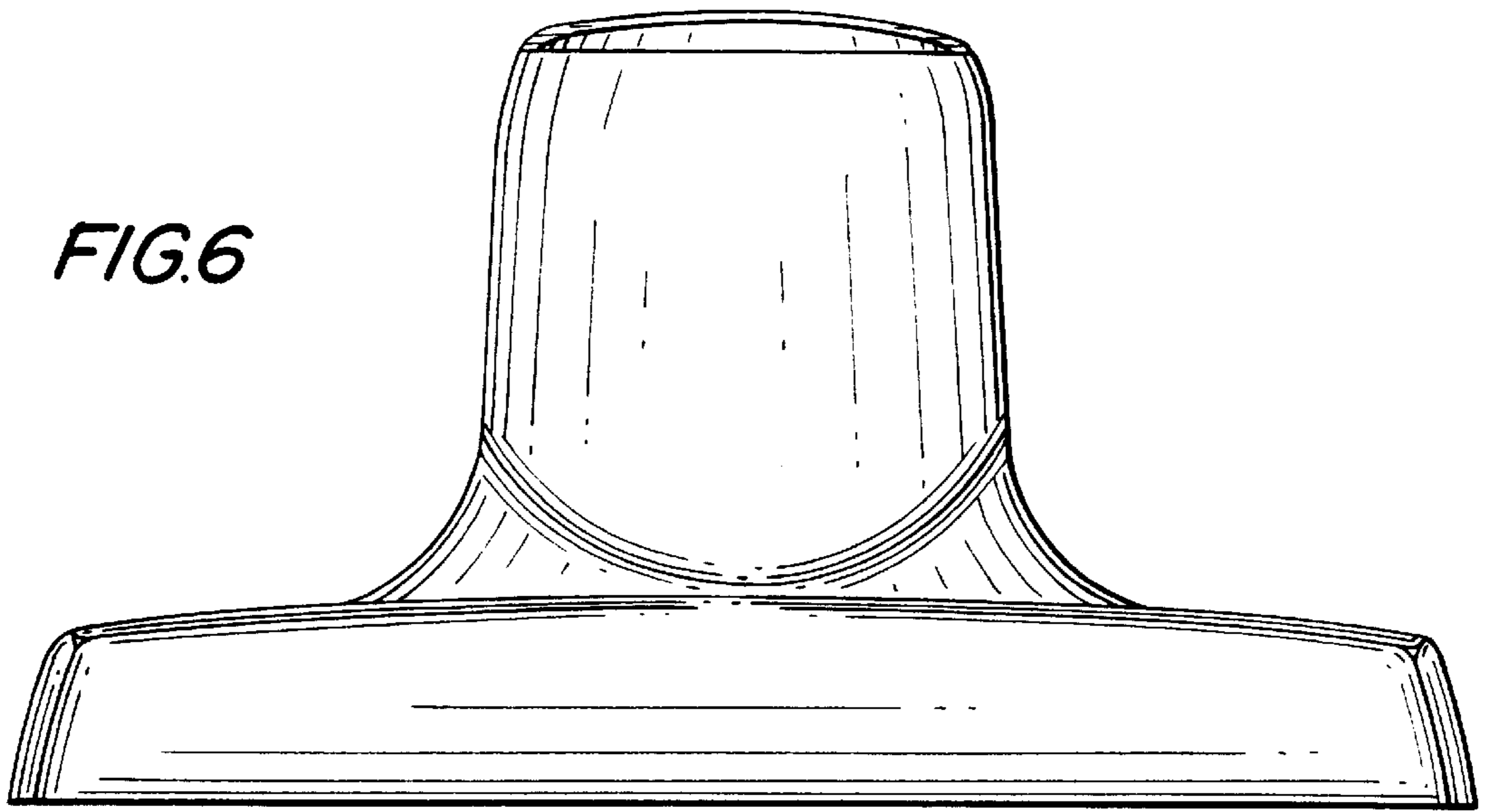
*FIG. 4*



*FIG. 5*



*FIG.6*



*FIG.7*

