



US00D470519S

(12) **United States Design Patent**
Ogura

(10) **Patent No.:** **US D470,519 S**

(45) **Date of Patent:** **** Feb. 18, 2003**

(54) **ELECTRIC STILL CAMERA**

(75) **Inventor:** **Ryosuke Ogura, Tokyo (JP)**

(73) **Assignee:** **Fuji Photo Film Co., Ltd., Kanagawa (JP)**

(**) **Term:** **14 Years**

(21) **Appl. No.:** **29/158,228**

(22) **Filed:** **Apr. 2, 2002**

(30) **Foreign Application Priority Data**

Oct. 4, 2001 (JP) 2001-029208

(51) **LOC (7) Cl.** **16-01**

(52) **U.S. Cl.** **D16/202; D16/212**

(58) **Field of Search** **D16/200-204, D16/208, 209, 211, 212, 218, 219; 348/373-376; 396/348, 349, 448, 536-541**

(56) **References Cited**

U.S. PATENT DOCUMENTS

- D369,372 S * 4/1996 Ishikawa et al. D16/218
- D401,258 S 11/1998 Tanaka D16/218
- D410,019 S * 5/1999 Shimobayashi et al. ... D16/209
- D410,665 S * 6/1999 Shinano D16/202
- 5,913,089 A * 6/1999 Ebe 396/448

- D449,324 S * 10/2001 Iue et al. D16/202
- D450,072 S 11/2001 Katayama D16/202
- D451,114 S * 11/2001 Tanaka D16/202
- 2002/0036702 A1 * 3/2002 Ohnogi 348/373

* cited by examiner

Primary Examiner—Adir Aronovich

(74) *Attorney, Agent, or Firm*—Young & Thompson

(57) **CLAIM**

The ornamental design for an electric still camera, as shown and described.

DESCRIPTION

FIG. 1 is a top, front and side perspective view of an electric still camera showing my new design;
 FIG. 2 is a front elevational view thereof;
 FIG. 3 is a rear elevational view thereof;
 FIG. 4 is a top plan view thereof;
 FIG. 5 is a bottom plan view thereof;
 FIG. 6 is a side elevational view thereof from the left of FIG. 2;
 FIG. 7 is a side elevational view thereof from the right of FIG. 2; and,
 FIG. 8 is a view similar to FIG. 1 but showing the parts in a different position.

1 Claim, 4 Drawing Sheets

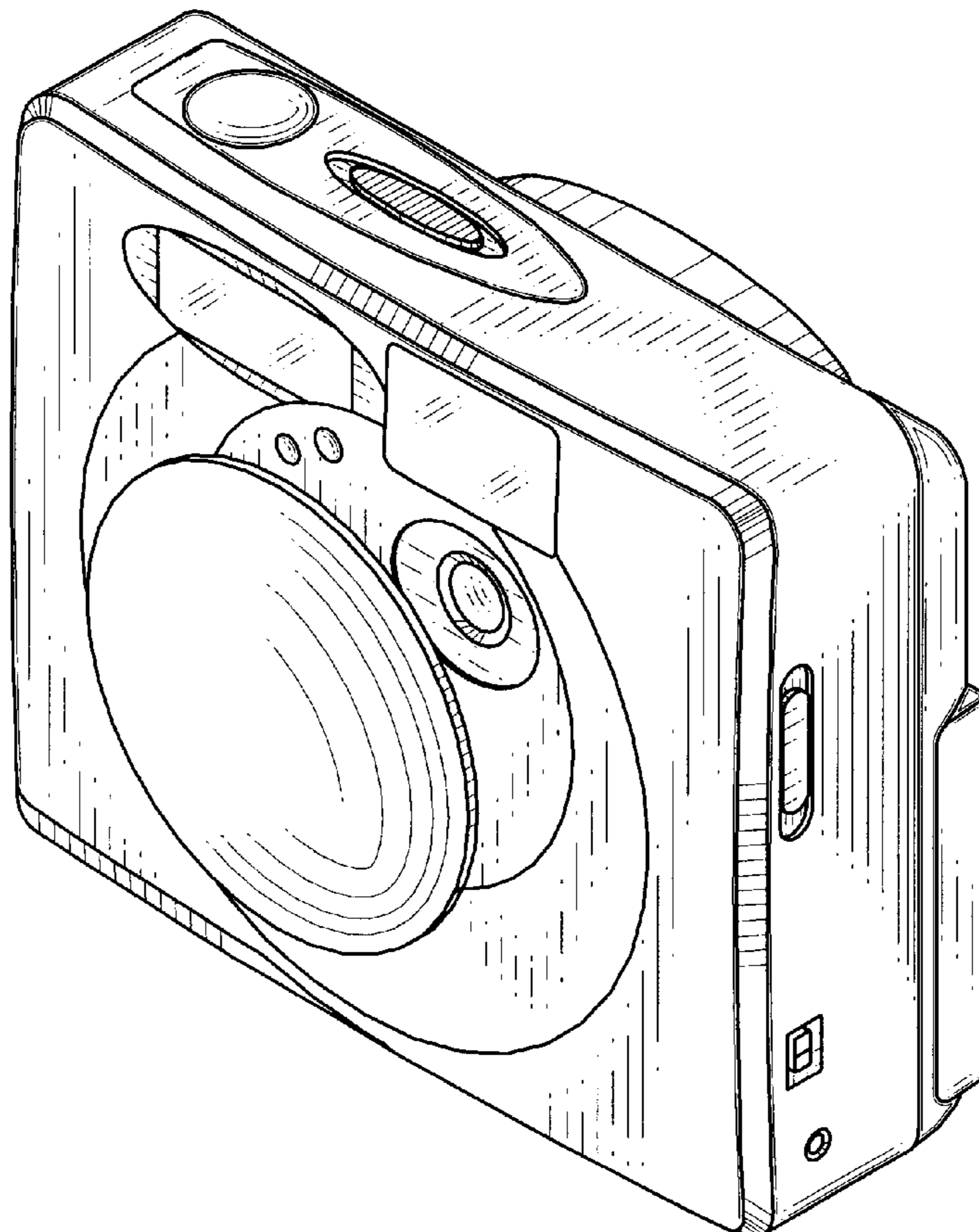

FIG. 1

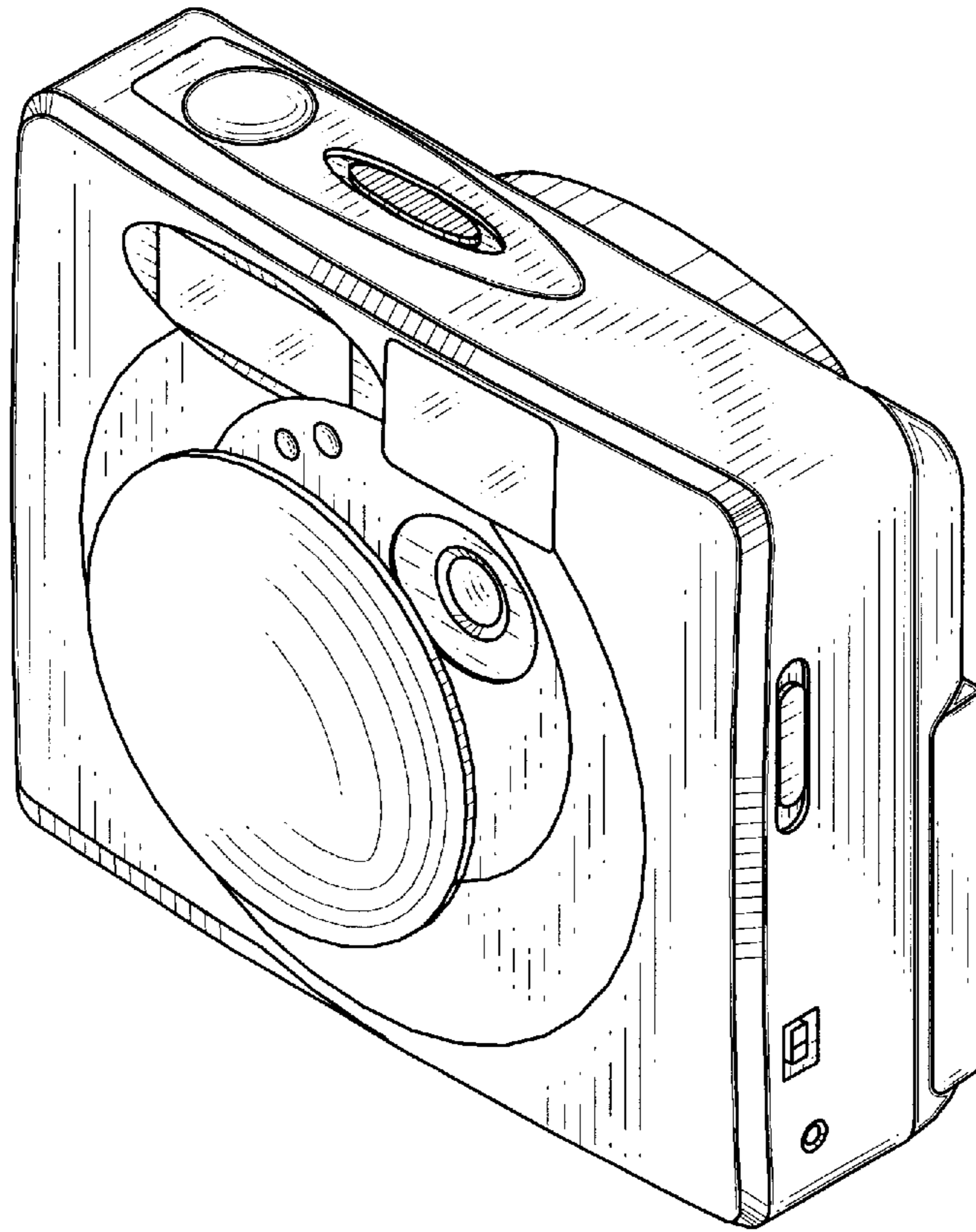

FIG. 2

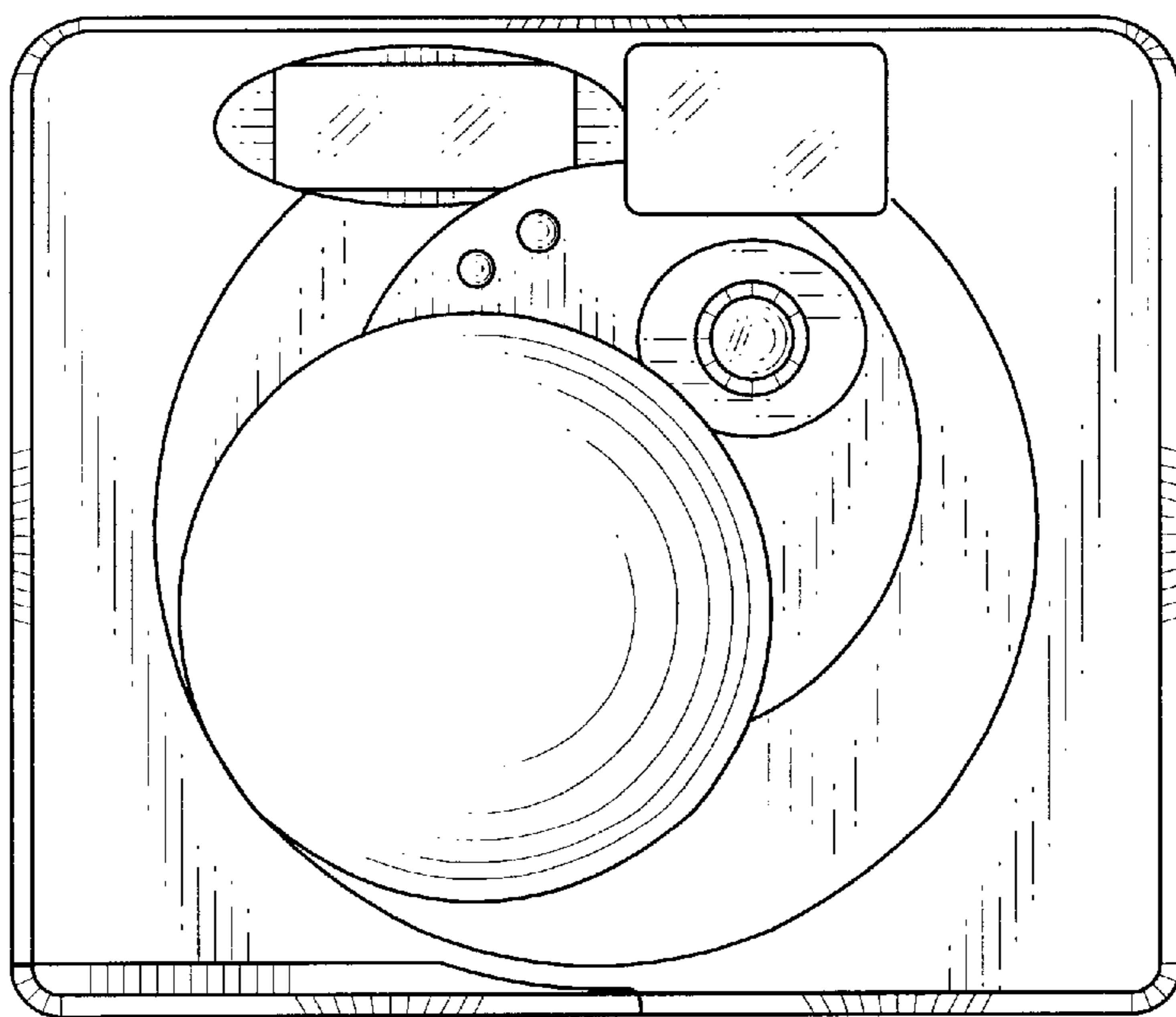

FIG. 3

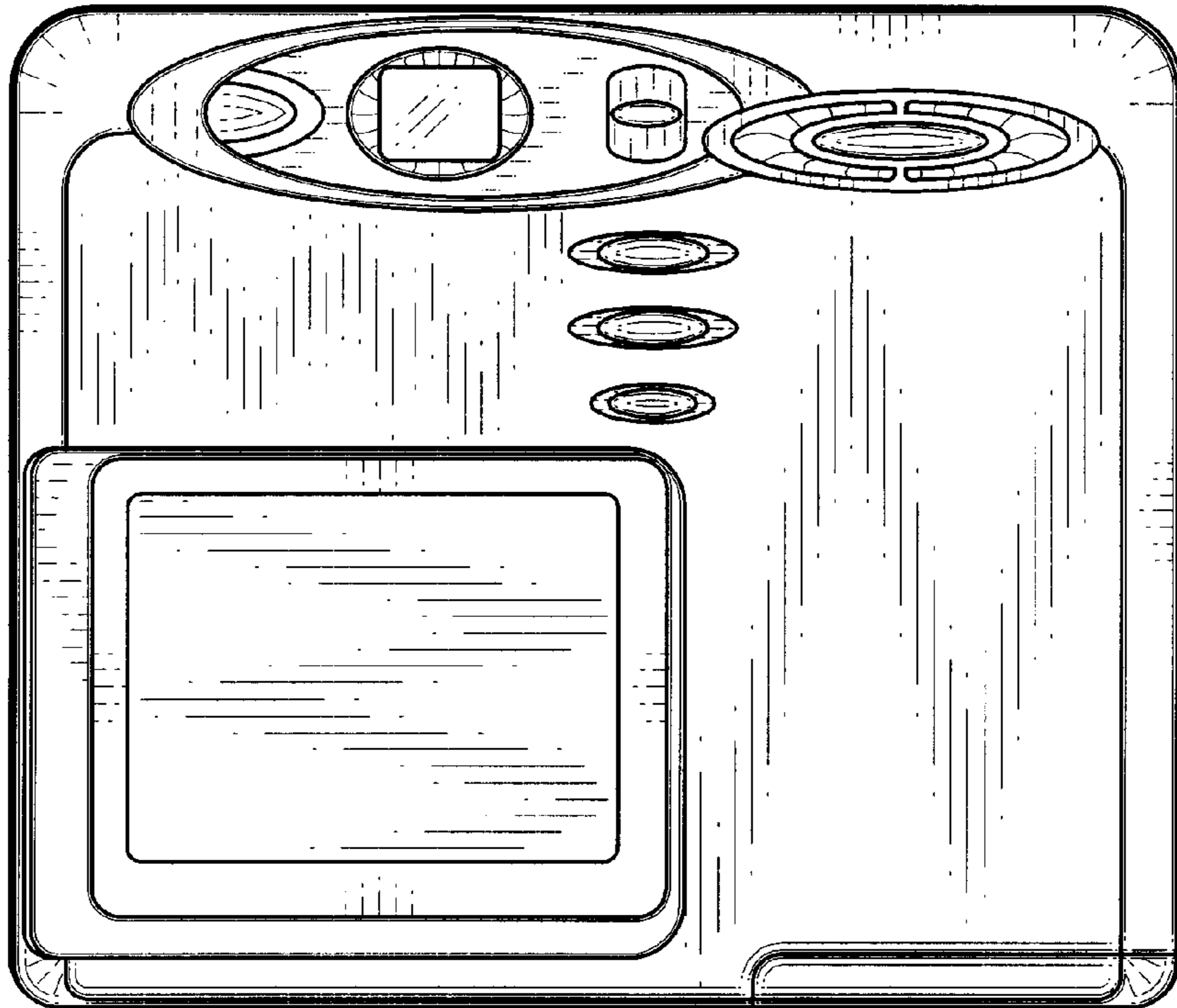

FIG. 4

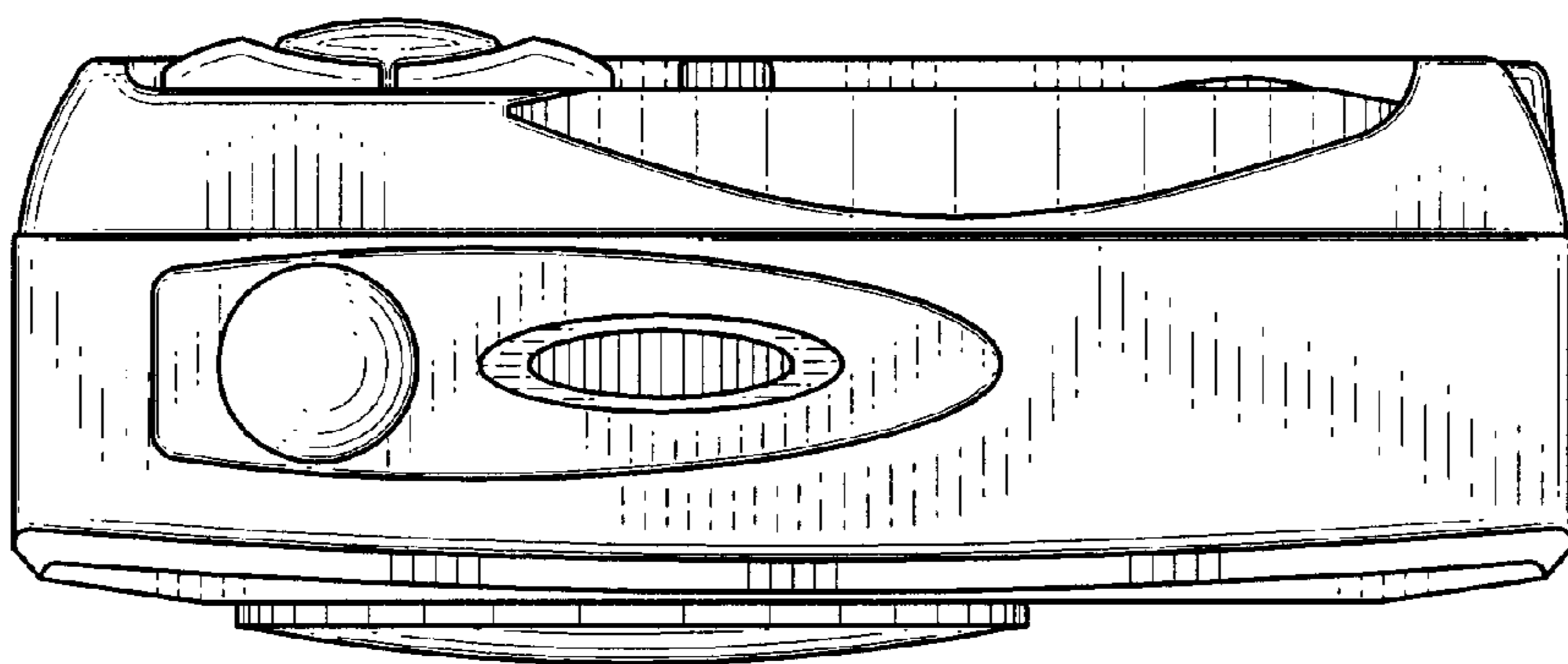

FIG. 5

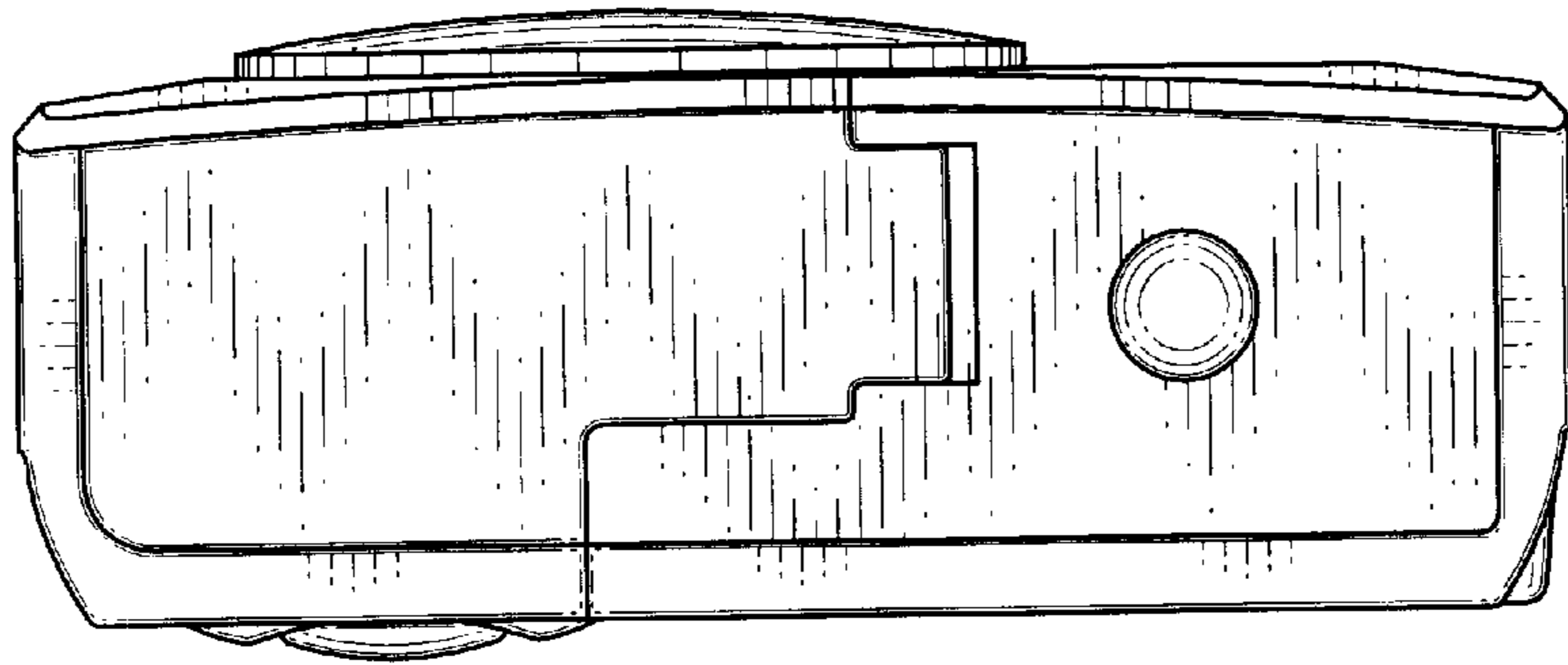

FIG. 6

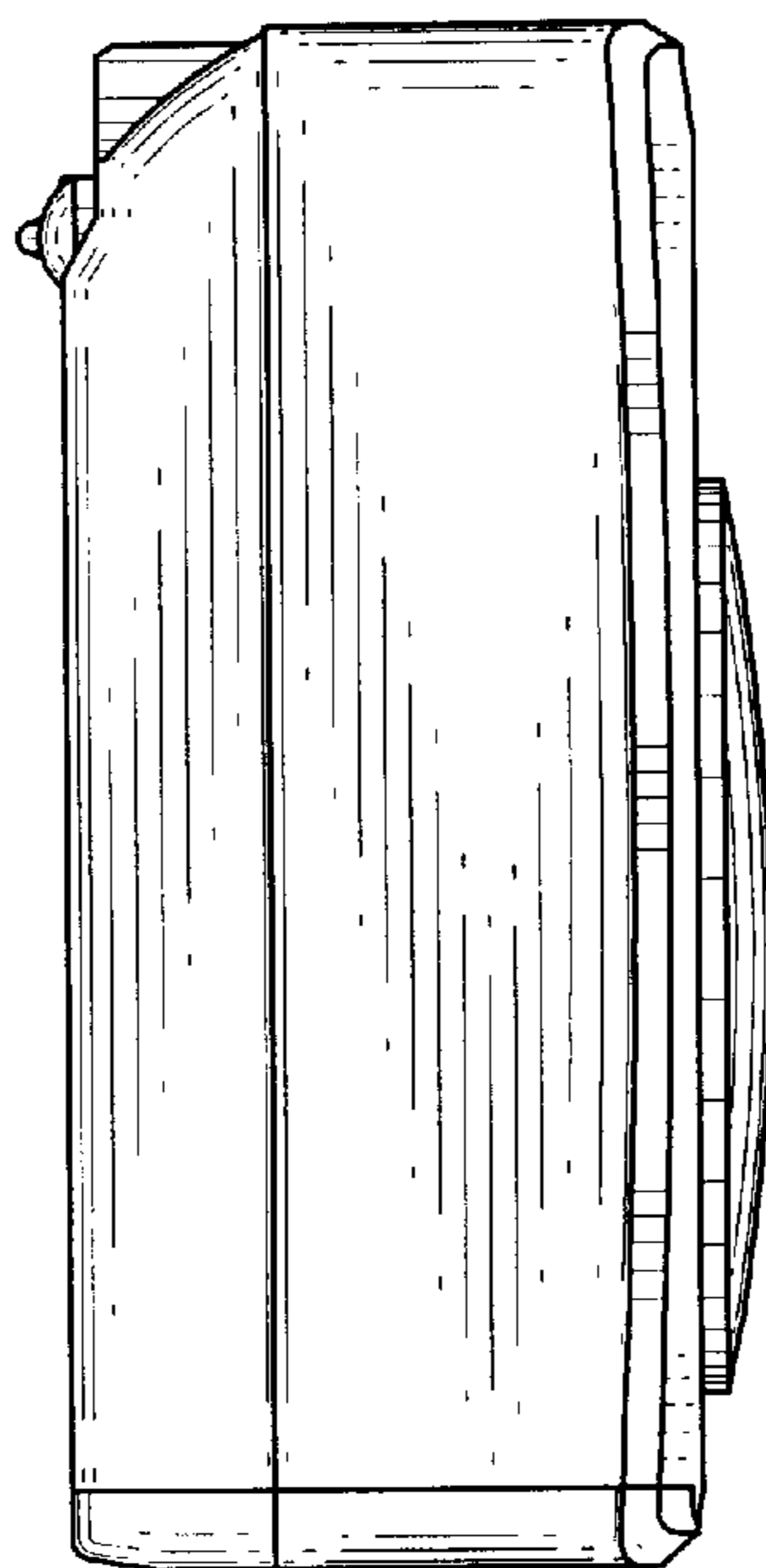

FIG. 7

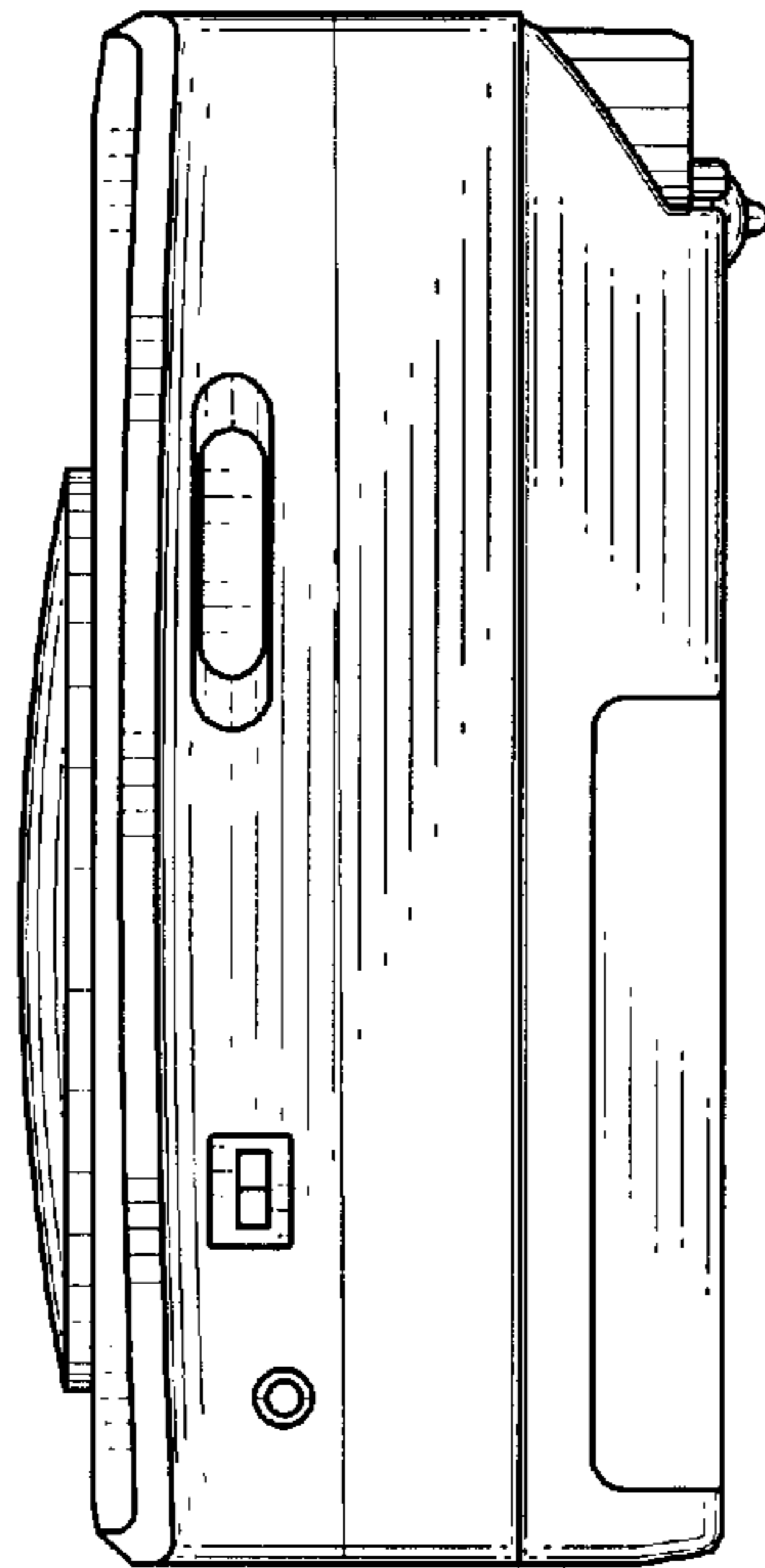

FIG. 8

