



US00D470435S

(12) **United States Design Patent**  
**Donckerwolke**

(10) **Patent No.:** **US D470,435 S**

(45) **Date of Patent:** **\*\* Feb. 18, 2003**

(54) **MOTOR VEHICLE**

D451,844 S \* 12/2001 Thomas ..... D12/92  
D455,102 S \* 4/2002 Crijns ..... D12/92

(75) Inventor: **Luc Donckerwolke**, Kosching (DE)

\* cited by examiner

(73) Assignee: **Audi AG**, Ingolstadt (DE)

*Primary Examiner*—Melody N. Brown

(\*\*) Term: **14 Years**

(74) *Attorney, Agent, or Firm*—Stevens, Davis, Miller & Mosher, LLP

(21) Appl. No.: **29/150,838**

(57) **CLAIM**

(22) Filed: **Nov. 30, 2001**

The ornamental design for a motor vehicle, as shown and described.

(30) **Foreign Application Priority Data**

Jul. 9, 2001 (DE) ..... DMA/005 374

**DESCRIPTION**

(51) **LOC (7) Cl.** ..... **12-08**

(52) **U.S. Cl.** ..... **D12/92**

(58) **Field of Search** ..... D12/90–92, 86,  
D12/88; 296/185

FIG. 1 is a perspective view of a motor vehicle embodying the design invention, taken from an upper, right side facing the vehicle.

FIG. 2 is a side elevational view thereof;

FIG. 3 is a front elevational view thereof; and,

FIG. 4 is a rear view thereof.

(56) **References Cited**

**U.S. PATENT DOCUMENTS**

D411,138 S \* 6/1999 Ramaciotti ..... D12/92

**1 Claim, 3 Drawing Sheets**

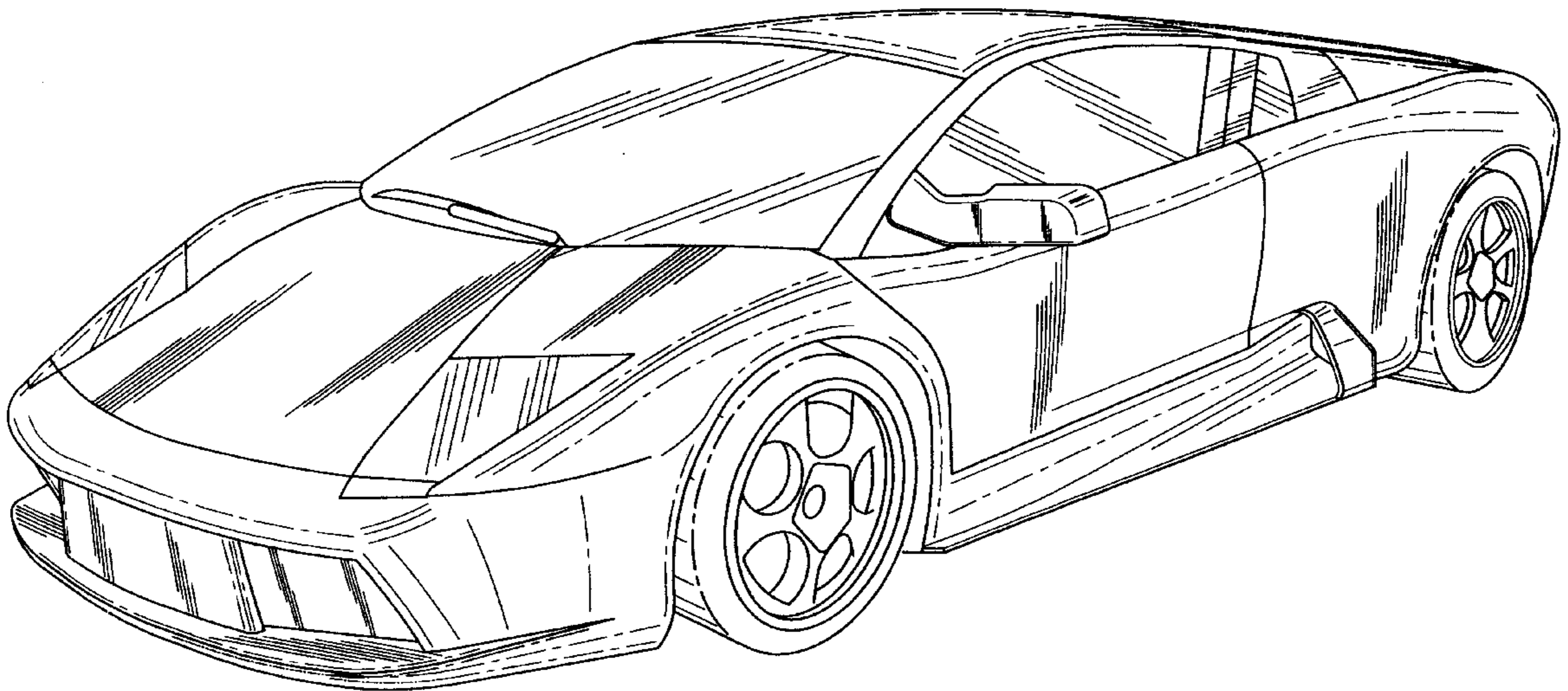

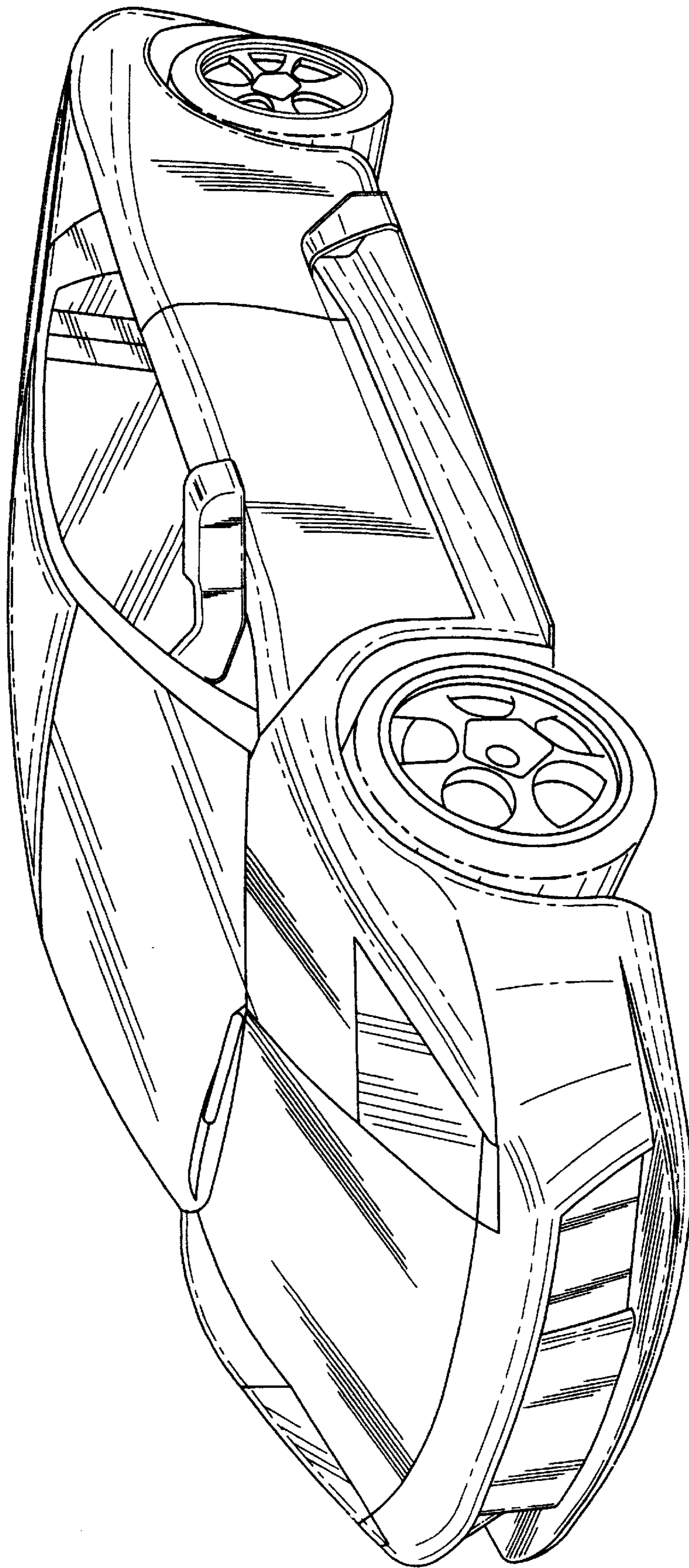

FIG. 1

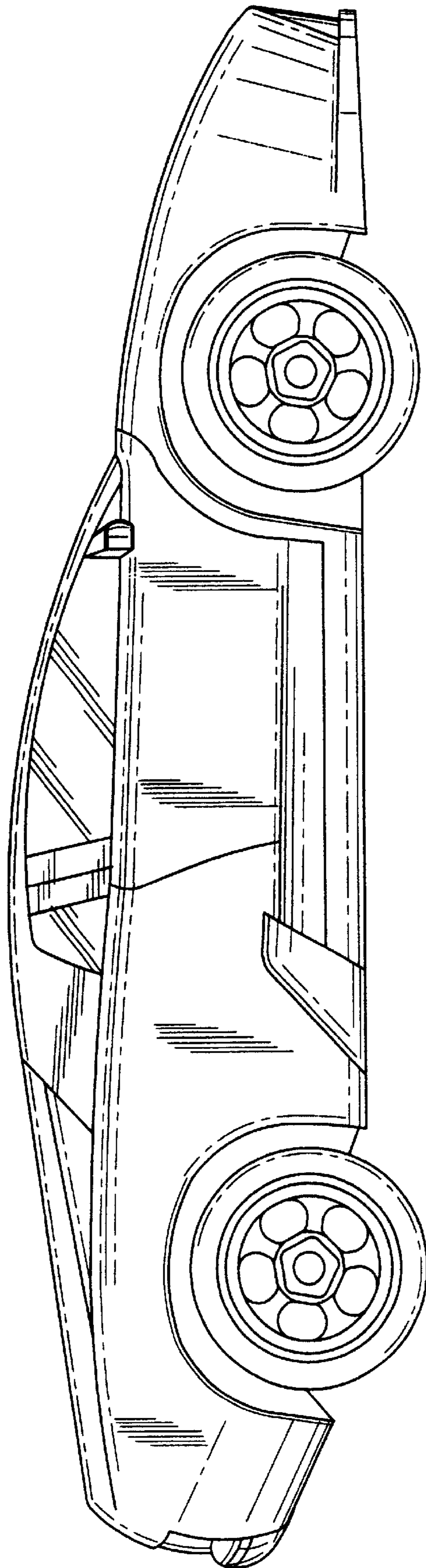

FIG. 2

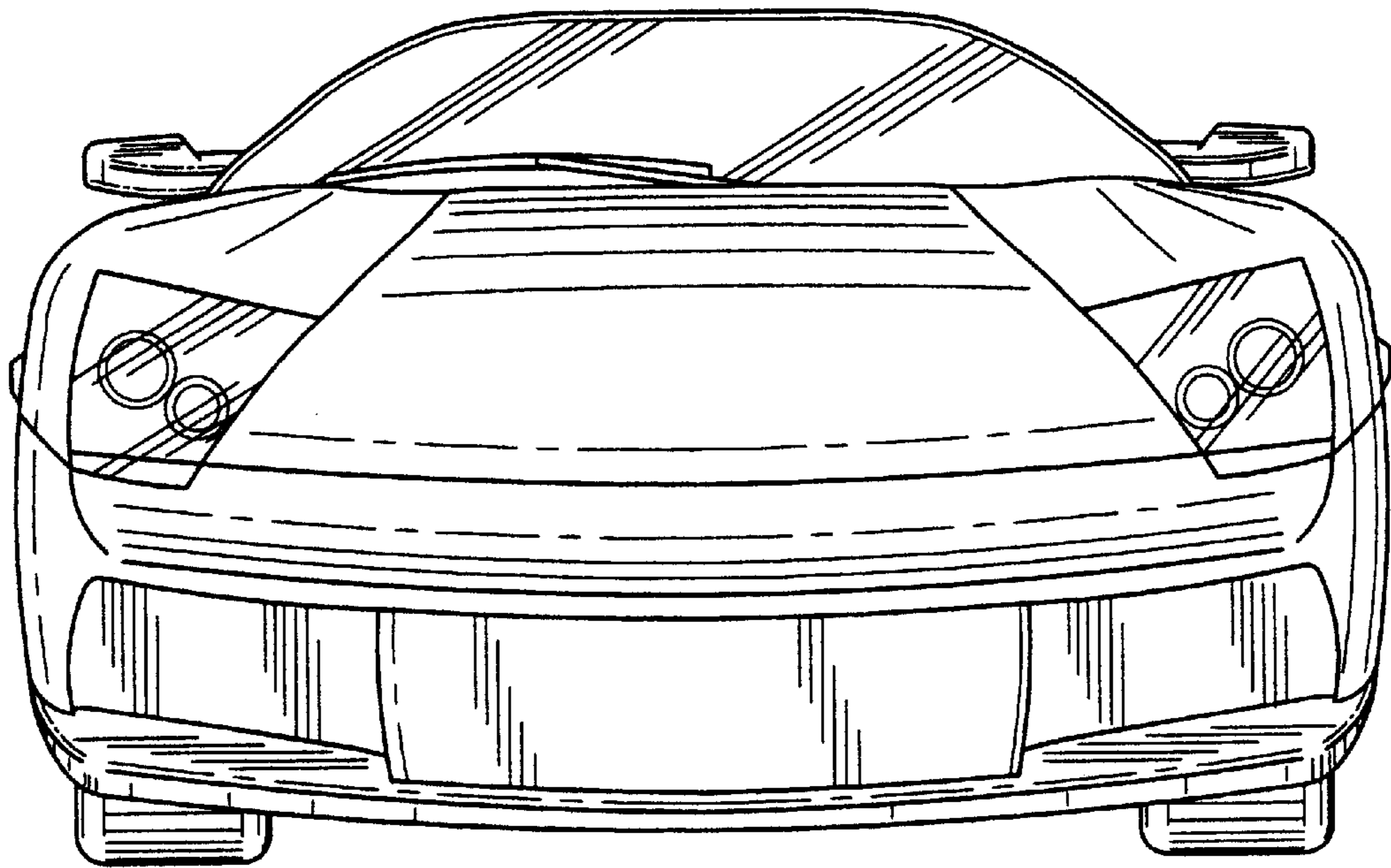

FIG.3

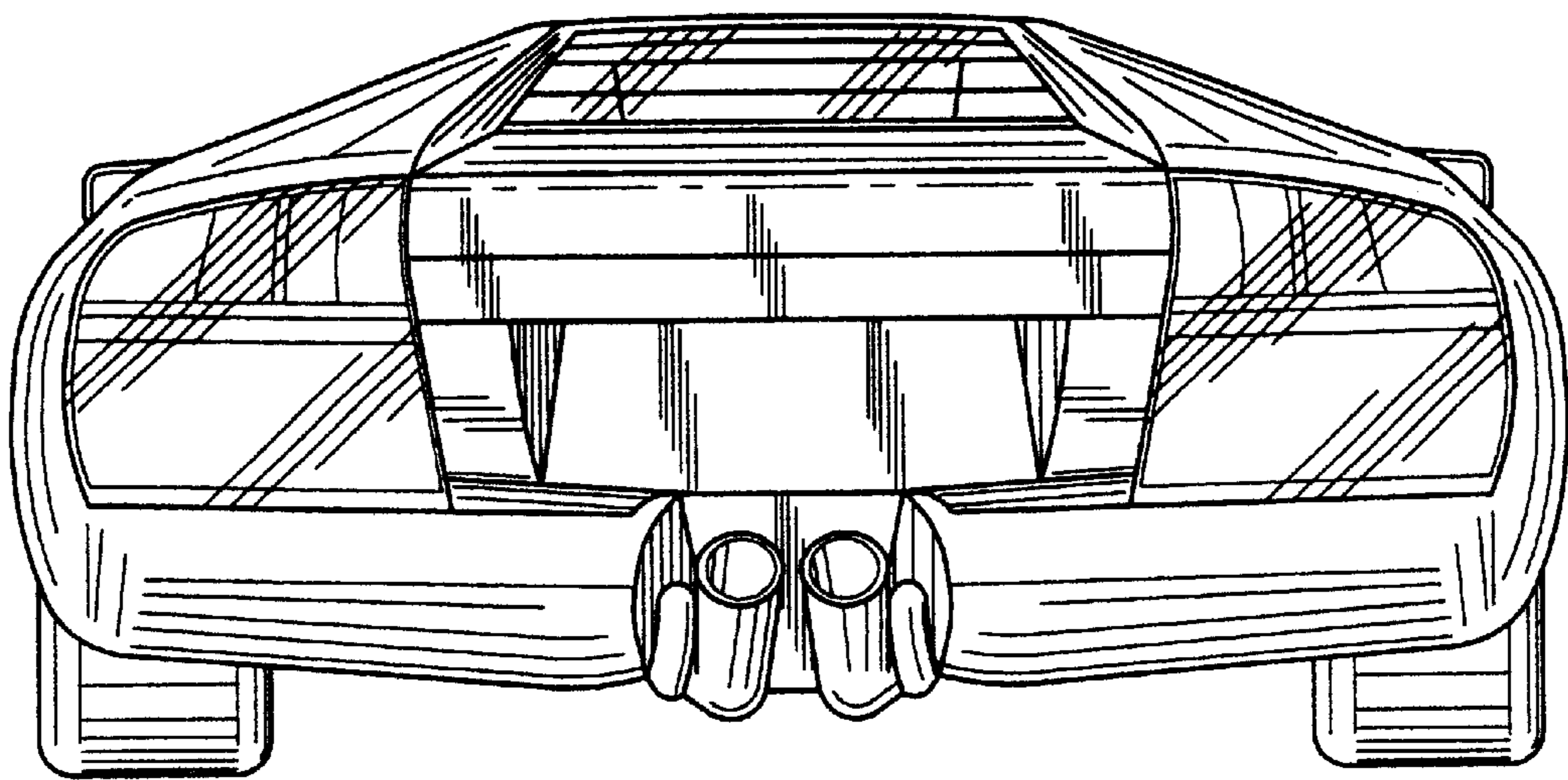

FIG.4