



US00D470400S

(12) **United States Design Patent**
Fraser et al.

(10) **Patent No.:** **US D470,400 S**

(45) **Date of Patent:** **** Feb. 18, 2003**

(54) **UMBRELLA CLAMP**

(76) Inventors: **Alan T. Fraser**, P. O. Box 82, Lower Sackville, Nova Scotia (CA), B4C 2S8;
Bryan Quinn, 30 Brookdale Crescent, Unit 412, Dartmouth, Nova Scotia (CA), B3A 4T7

(**) Term: **14 Years**

(21) Appl. No.: **29/137,817**

(22) Filed: **Mar. 1, 2001**

(51) **LOC (7) Cl.** **08-08**

(52) **U.S. Cl.** **D8/396**

(58) **Field of Search** D8/394-396, 354, D8/355; D3/10; D6/416, 418; 248/229.1, 218.4, 219.3, 229.15, 226.11, 230.1, 230.6, 228.6, 231.7, 309.1, 313, 316.1

(56) **References Cited**

U.S. PATENT DOCUMENTS

5,524,667 A * 6/1996 Potter 248/228.6
D389,334 S * 1/1998 Attridge D6/418

D396,185 S * 7/1998 Fraser D8/396
5,823,657 A * 10/1998 Price et al. 248/229.15
D413,429 S * 9/1999 Carson D3/10

* cited by examiner

Primary Examiner—Louis S. Zarfes
Assistant Examiner—Deanne Levy
(74) *Attorney, Agent, or Firm*—Mario Theriault

(57) **CLAIM**

The ornamental design for an umbrella clamp, as shown and described.

DESCRIPTION

FIG. 1 is a front, right side and top perspective view of an umbrella clamp showing our new design;
FIG. 2 is a front view thereof;
FIG. 3 is a rear view thereof;
FIG. 4 is a top view thereof;
FIG. 5 is a right side view thereof; the left side view being a mirror image with the exclusion of the thumb-screw; and,
FIG. 6 is a bottom view thereof.

1 Claim, 2 Drawing Sheets

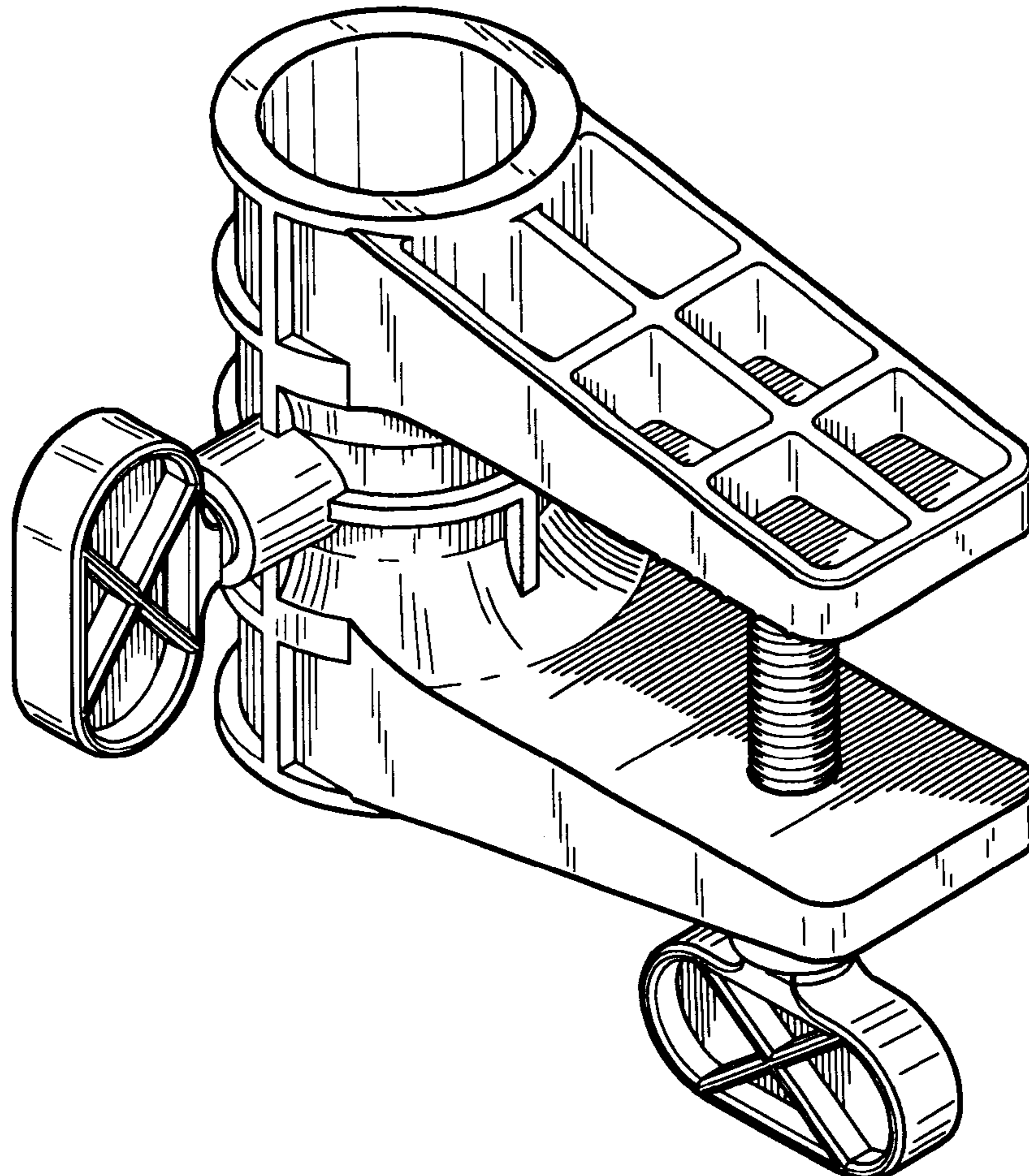

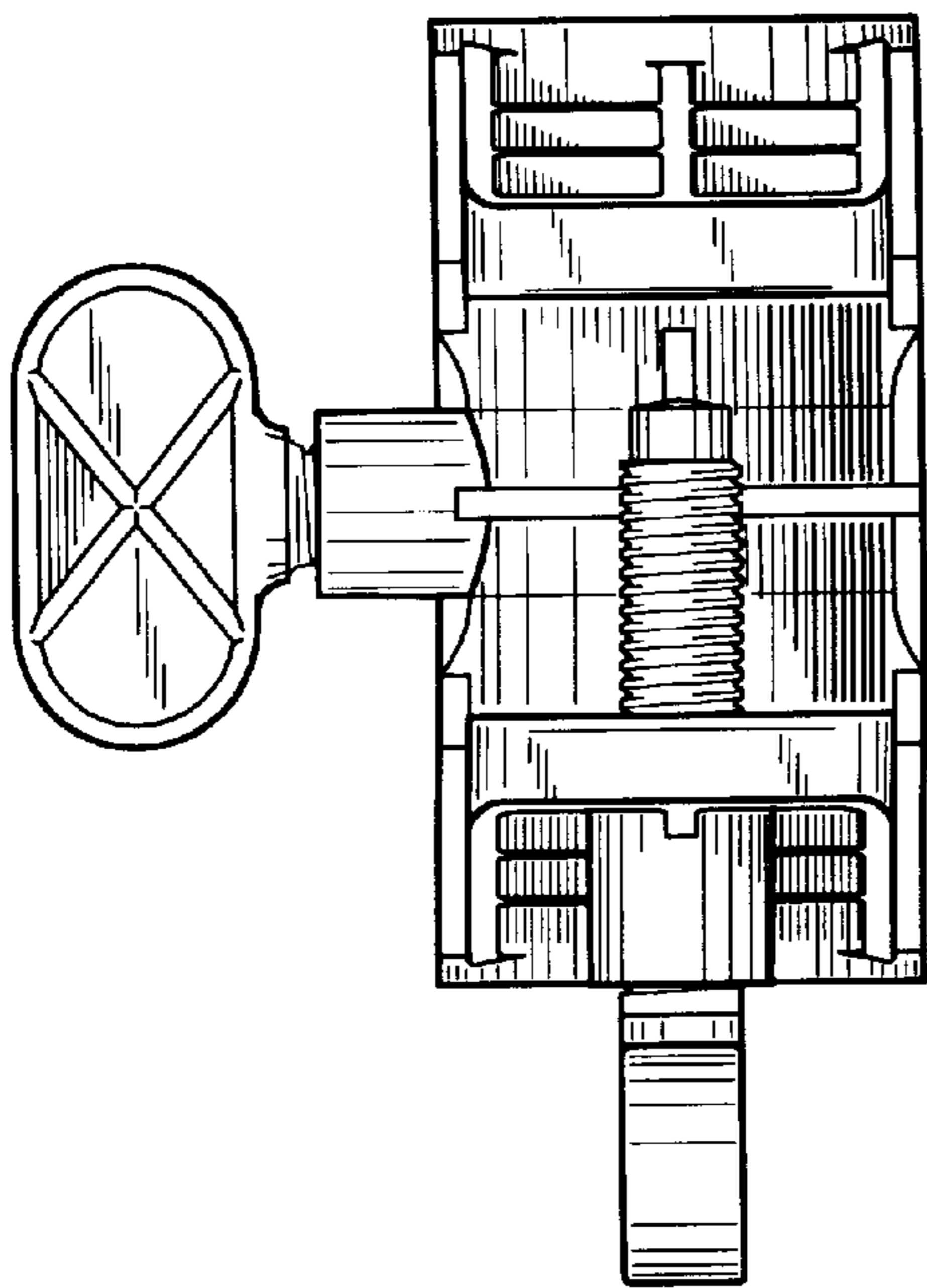

FIG. 2

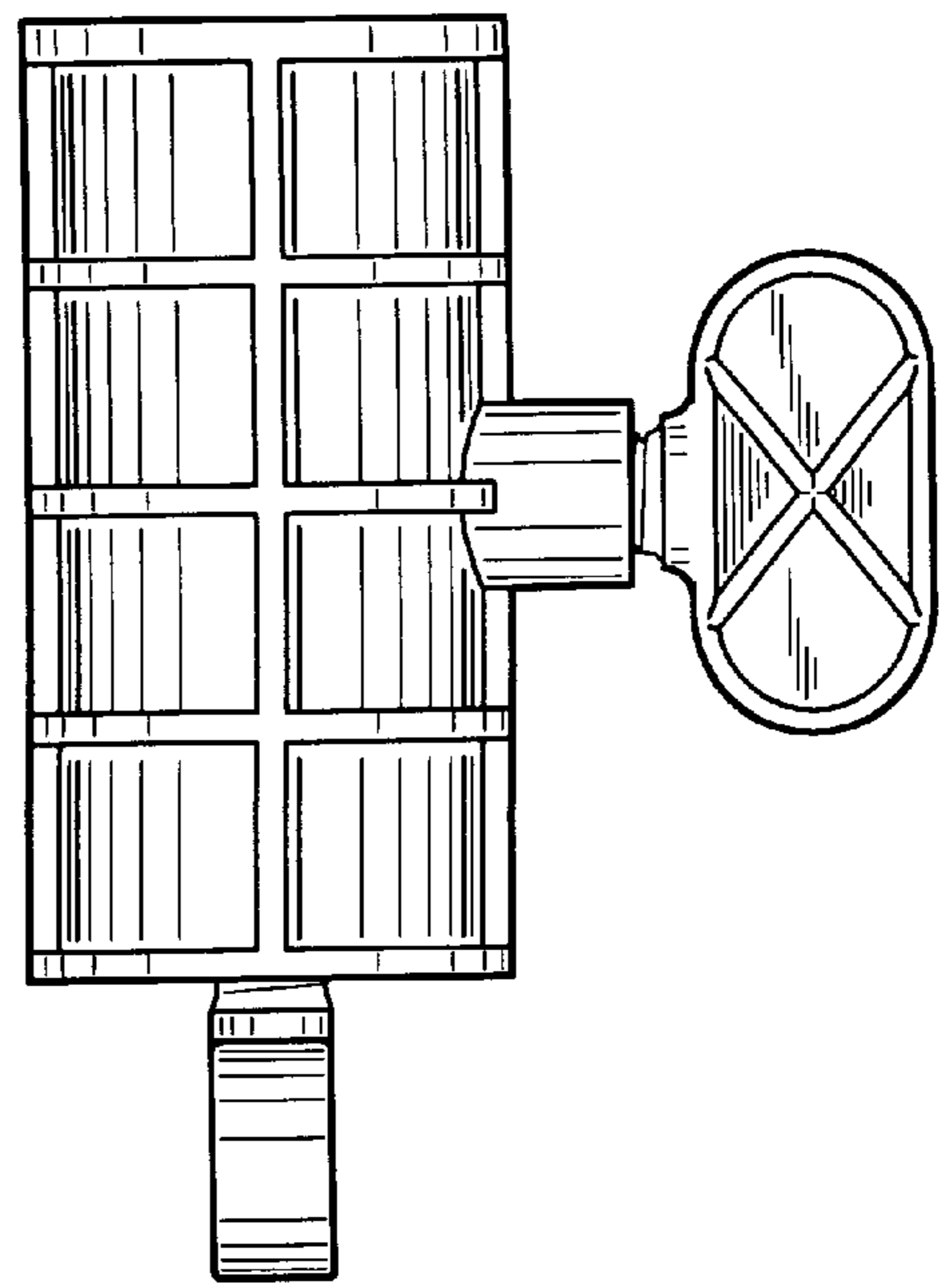

FIG. 3

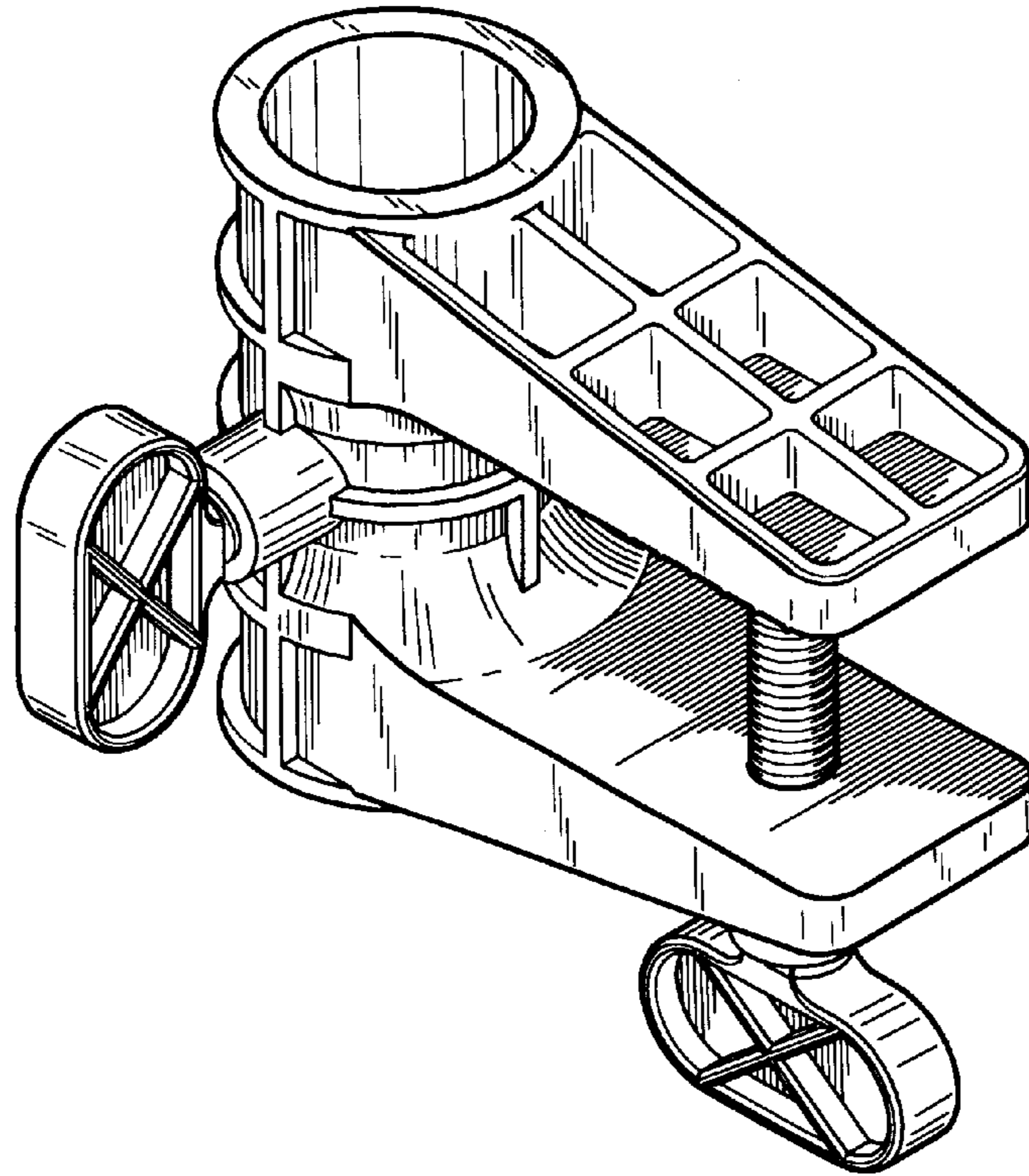

FIG. 1

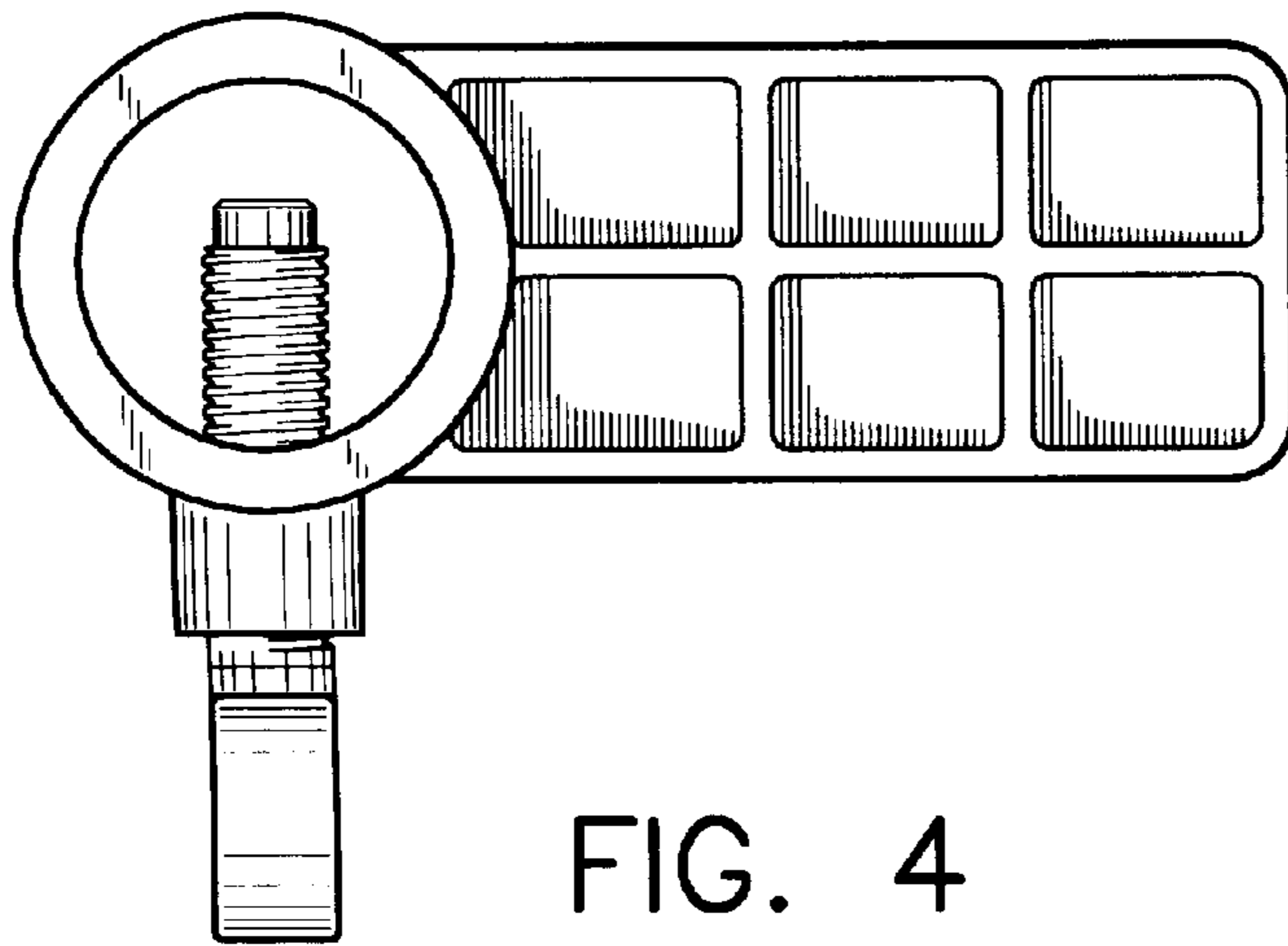

FIG. 4

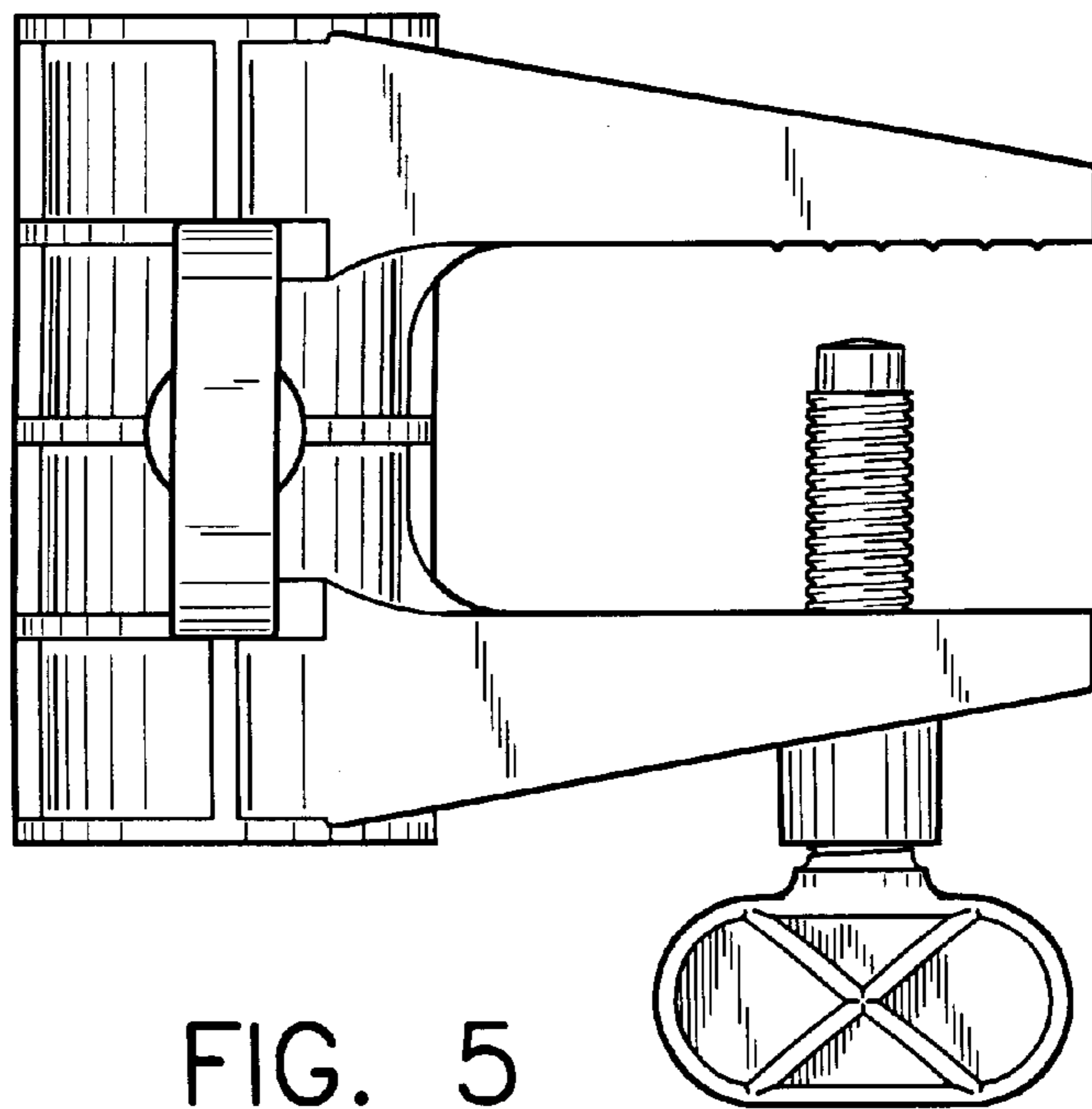

FIG. 5

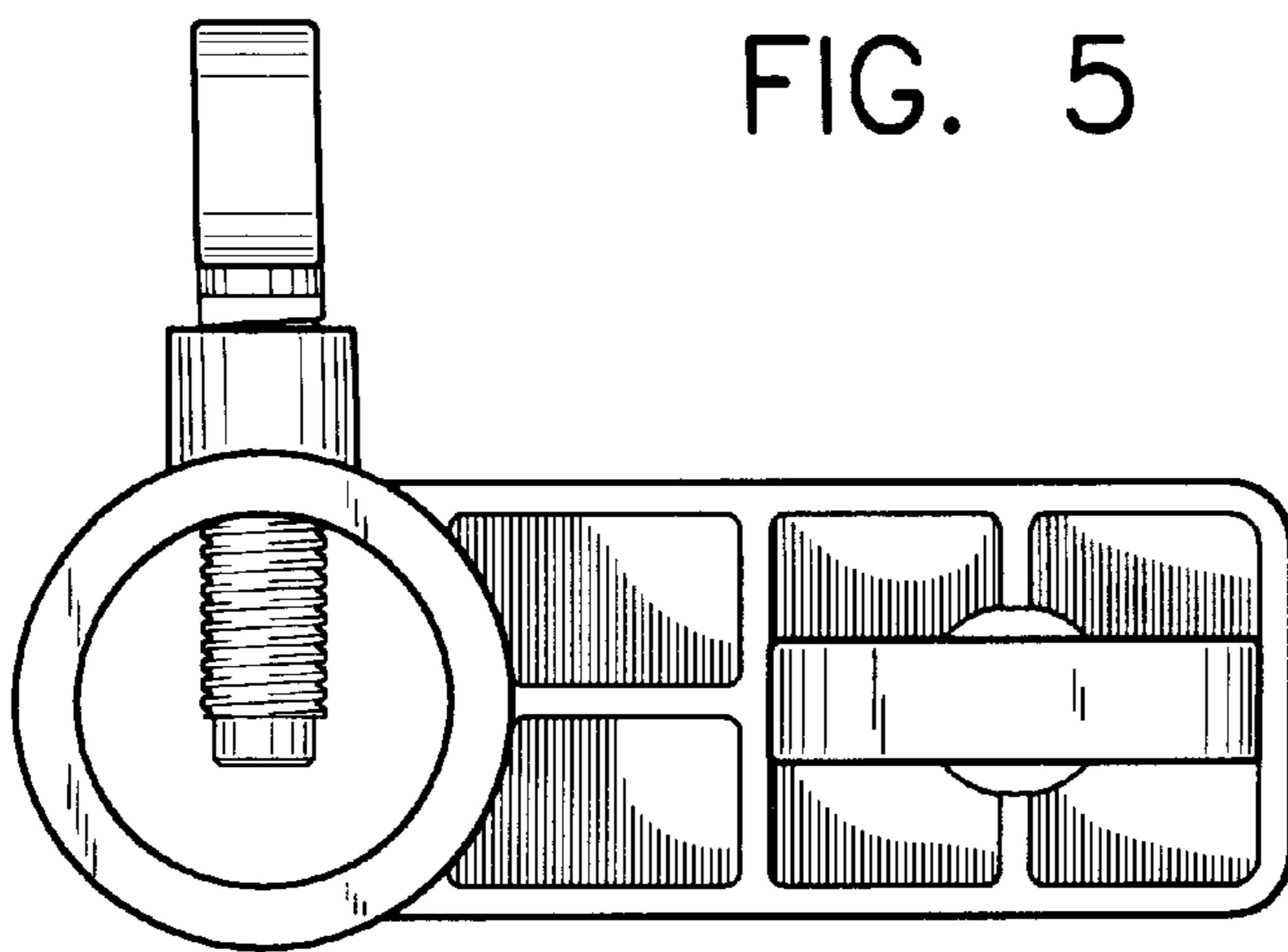

FIG. 6