



US00D470292S

(12) **United States Design Patent**
Johnson et al.

(10) **Patent No.:** **US D470,292 S**

(45) **Date of Patent:** **** Feb. 11, 2003**

(54) **CART**

(75) Inventors: **Christopher M. Johnson**, Richmond, VA (US); **Terrill M. Porter**, Richmond, VA (US); **Ralph C. McCann**, Richmond, VA (US); **Norm DeCost**, Midlothian, VA (US); **Robert G. Butterfield**, Lanesbrough, MA (US); **George Inashvili**, Pittsfield, MA (US); **Joseph T. Woods**, Chicopee, MA (US); **Lawrence J. Doheny**, Holly Springs, NC (US); **William Grant**, Lanesbrough, MA (US)

(73) Assignees: **Rehrig International Inc.**, Richmond, VA (US); **GE Plastics Business Unit**, Pittsfield, MA (US)

(**) Term: **14 Years**

(21) Appl. No.: **29/157,827**

(22) Filed: **Mar. 27, 2002**

(51) **LOC (7) Cl.** **12-02**

(52) **U.S. Cl.** **D34/19**

(58) **Field of Search** ... D34/12-27; 280/33.991-33.997, 280/47.34, 47.35

(56) **References Cited**

U.S. PATENT DOCUMENTS

- D188,841 S * 9/1960 Umanoff D34/19
- 5,203,578 A * 4/1993 Davidson et al. 280/33.991
- 5,441,288 A * 8/1995 Rehrig 280/33.991
- D366,546 S * 1/1996 Schaub et al. D34/20

- 5,947,313 A * 9/1999 Kern et al. 220/4.01
- D444,281 S * 6/2001 Gaze et al. D34/19
- 2002/0135144 A1 9/2002 Murar et al. 280/33.991

* cited by examiner

Primary Examiner—Kay H. Chin

(74) *Attorney, Agent, or Firm*—McGuireWoods LLP

(57) **CLAIM**

The ornamental design for a cart, as shown and described.

DESCRIPTION

FIG. 1 is a perspective view of a first embodiment of a cart; FIG. 2 is a side elevation view of the first embodiment of the cart; FIG. 3 is a front elevation view of the first embodiment of the cart; FIG. 4 is a rear elevation view of the first embodiment of the cart; FIG. 5 is a top plan view of the first embodiment of the cart; FIG. 6 is a bottom plan view of the first embodiment of the cart; FIG. 7 is a side elevation view of a second embodiment of the cart; FIG. 8 is a top plan view of the second embodiment of the cart; and, FIG. 9 is a front elevation view of the second embodiment of the cart.

The bottom, rear and perspective view of the second embodiment of the cart is not shown, but are substantially the same as those views of the first embodiment except for the grid pattern of the cart, itself.

1 Claim, 6 Drawing Sheets

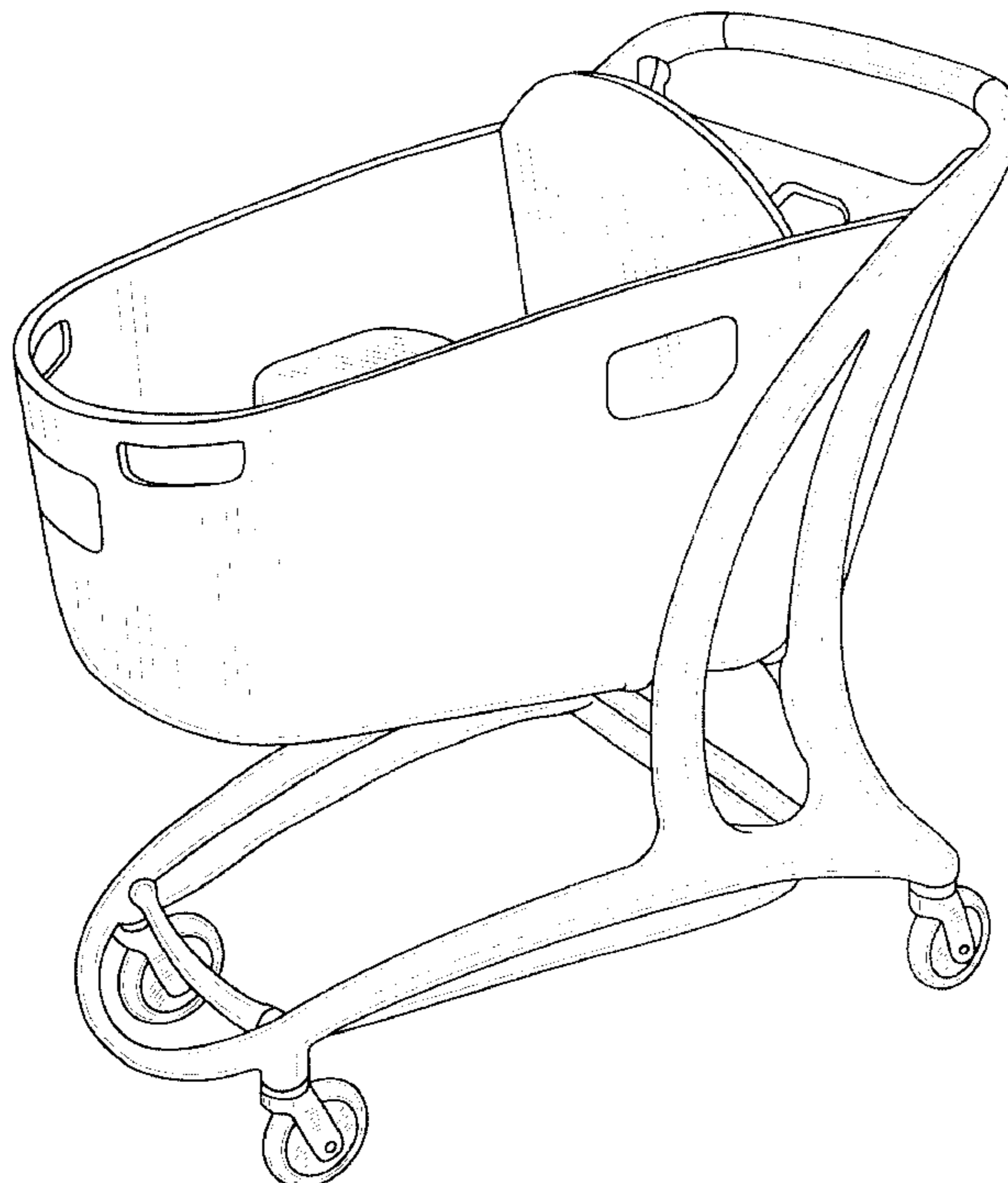

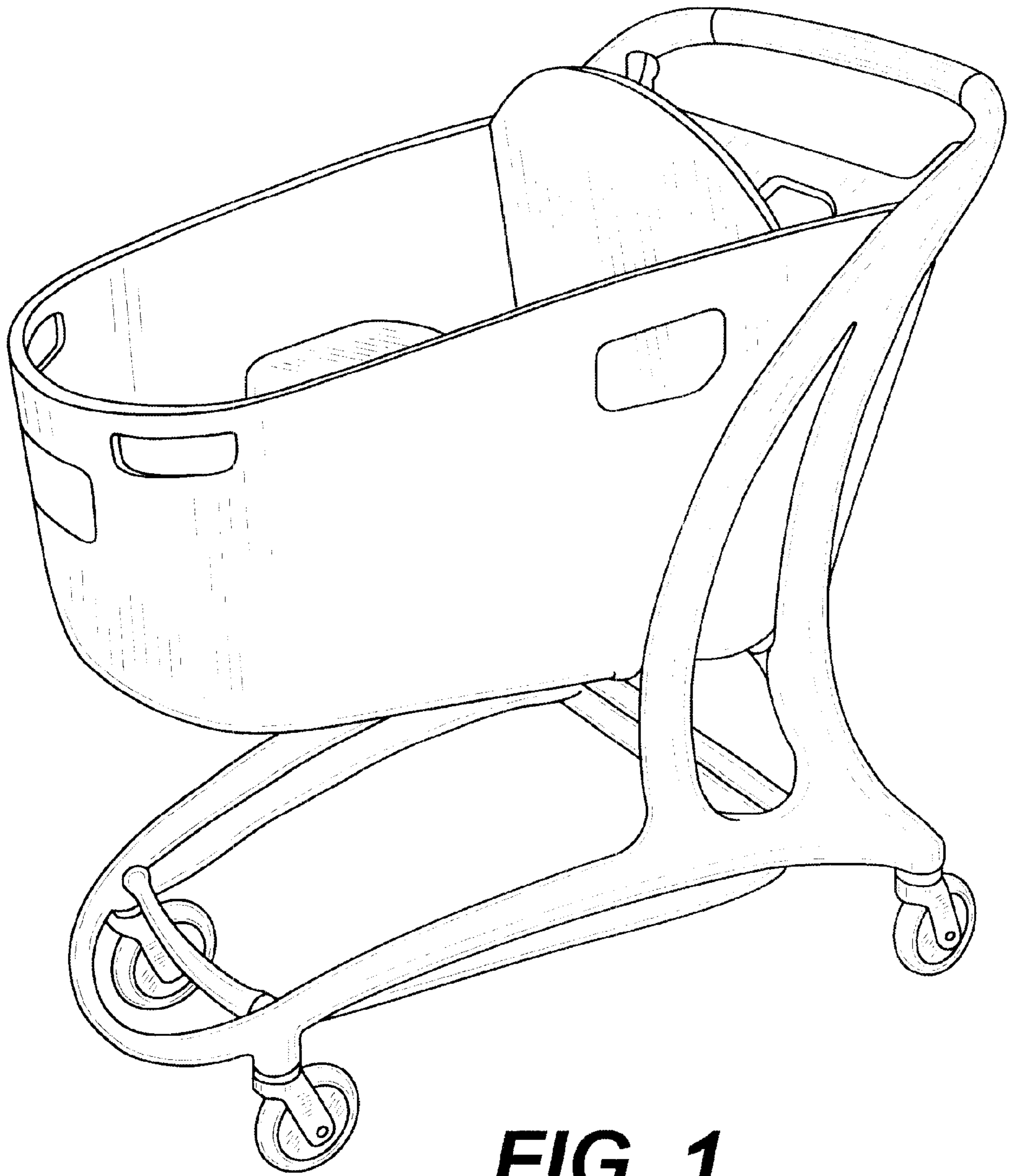

FIG. 1

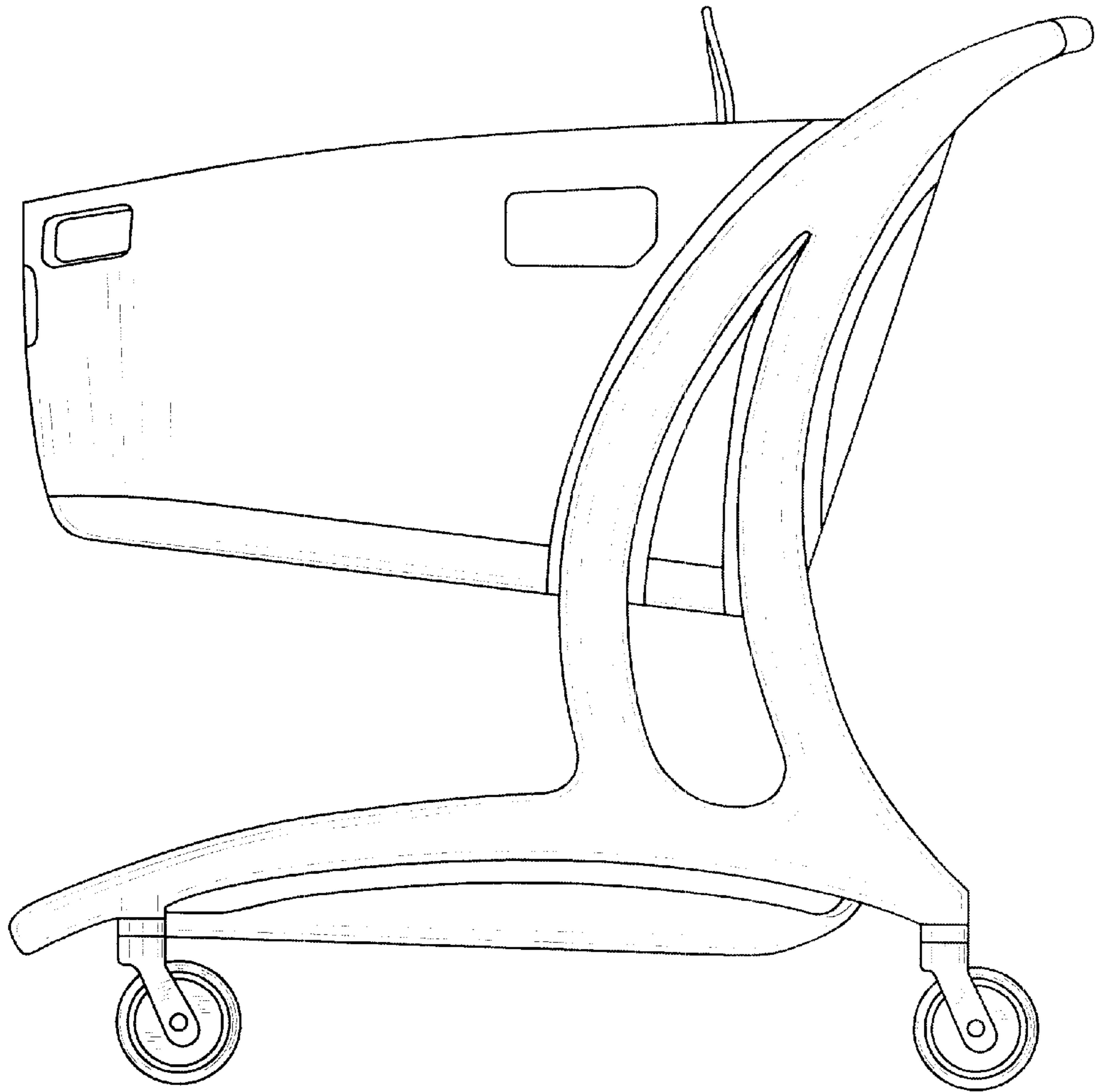

FIG. 2

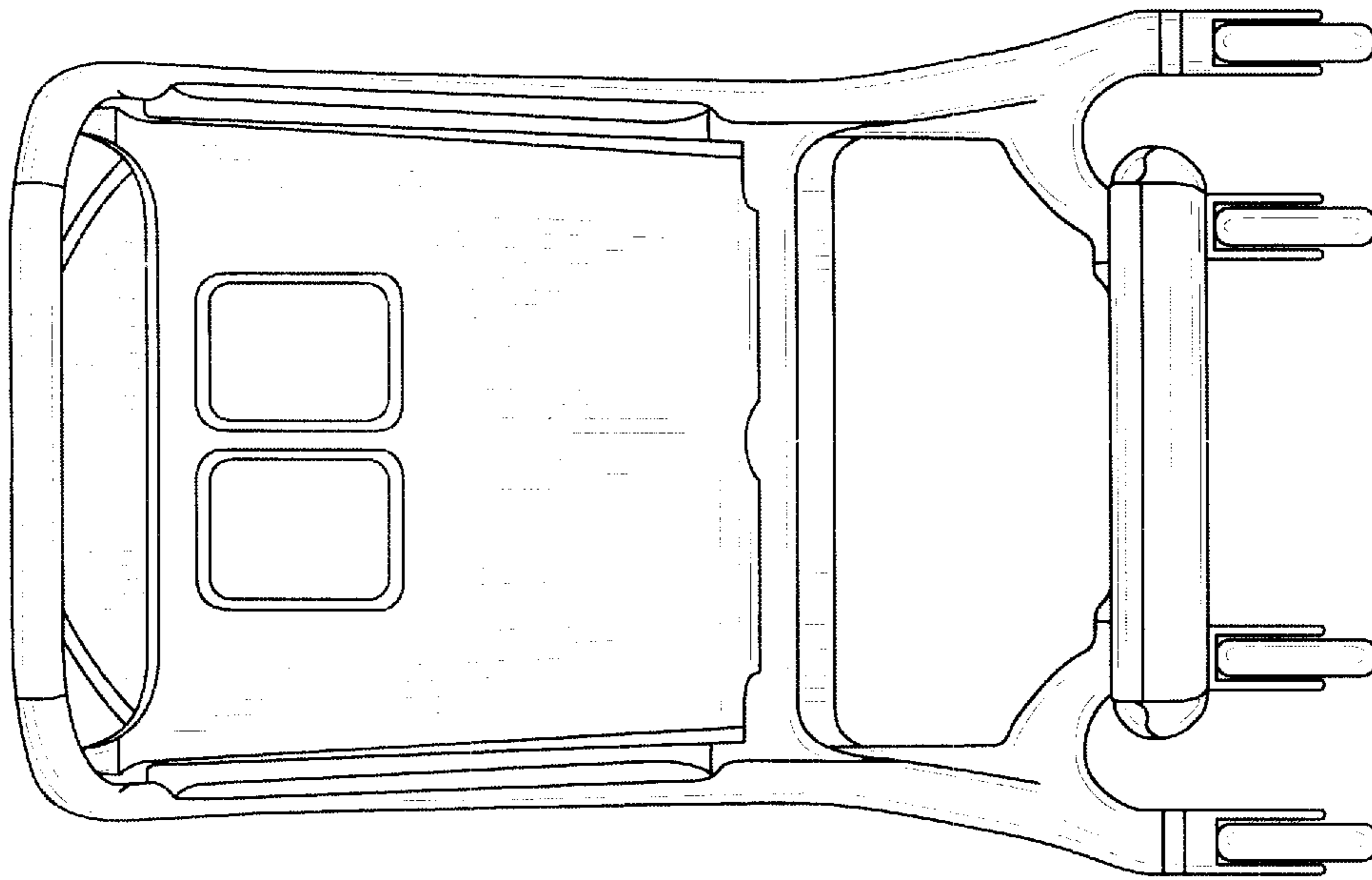

FIG. 4

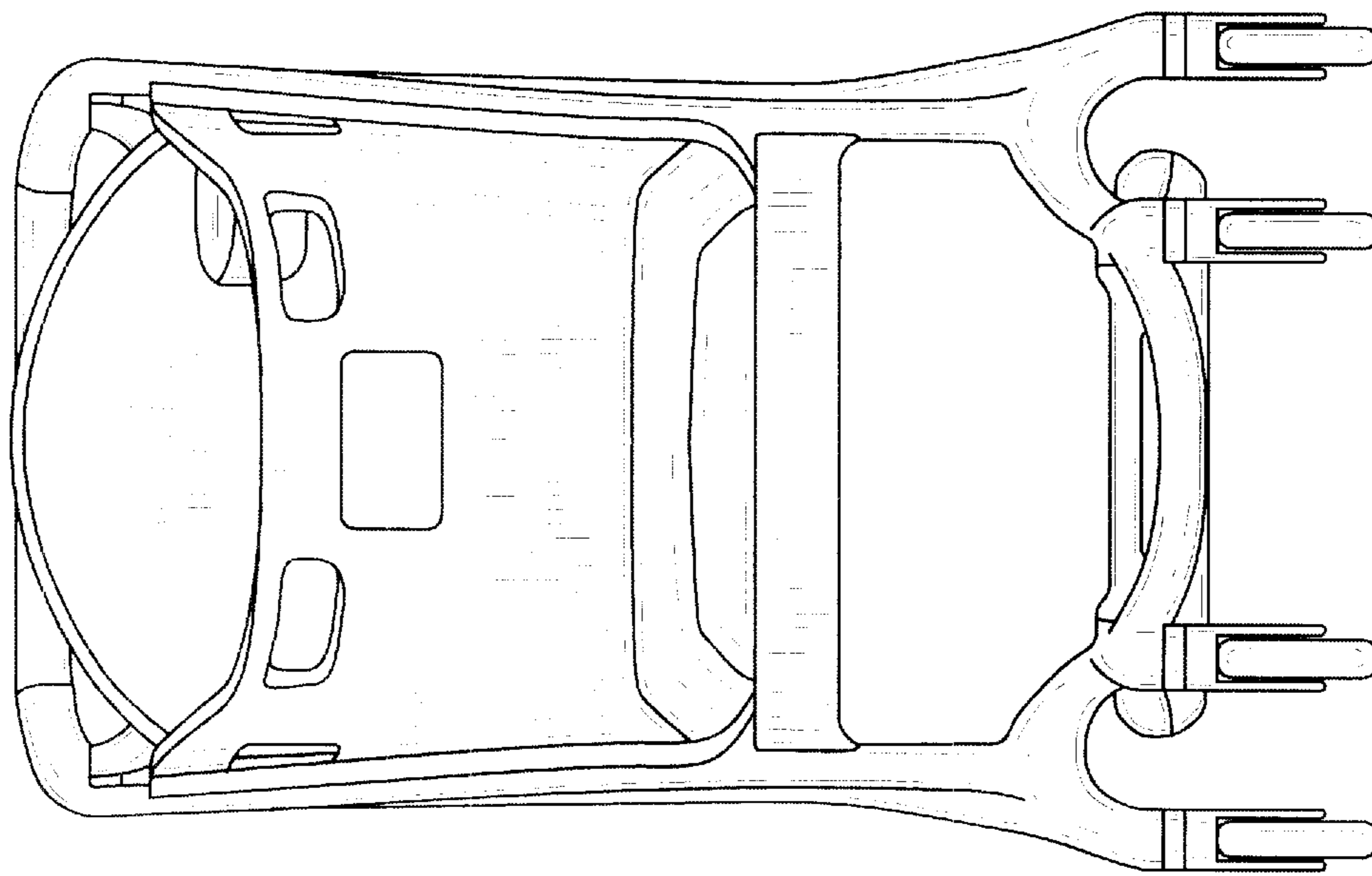

FIG. 3

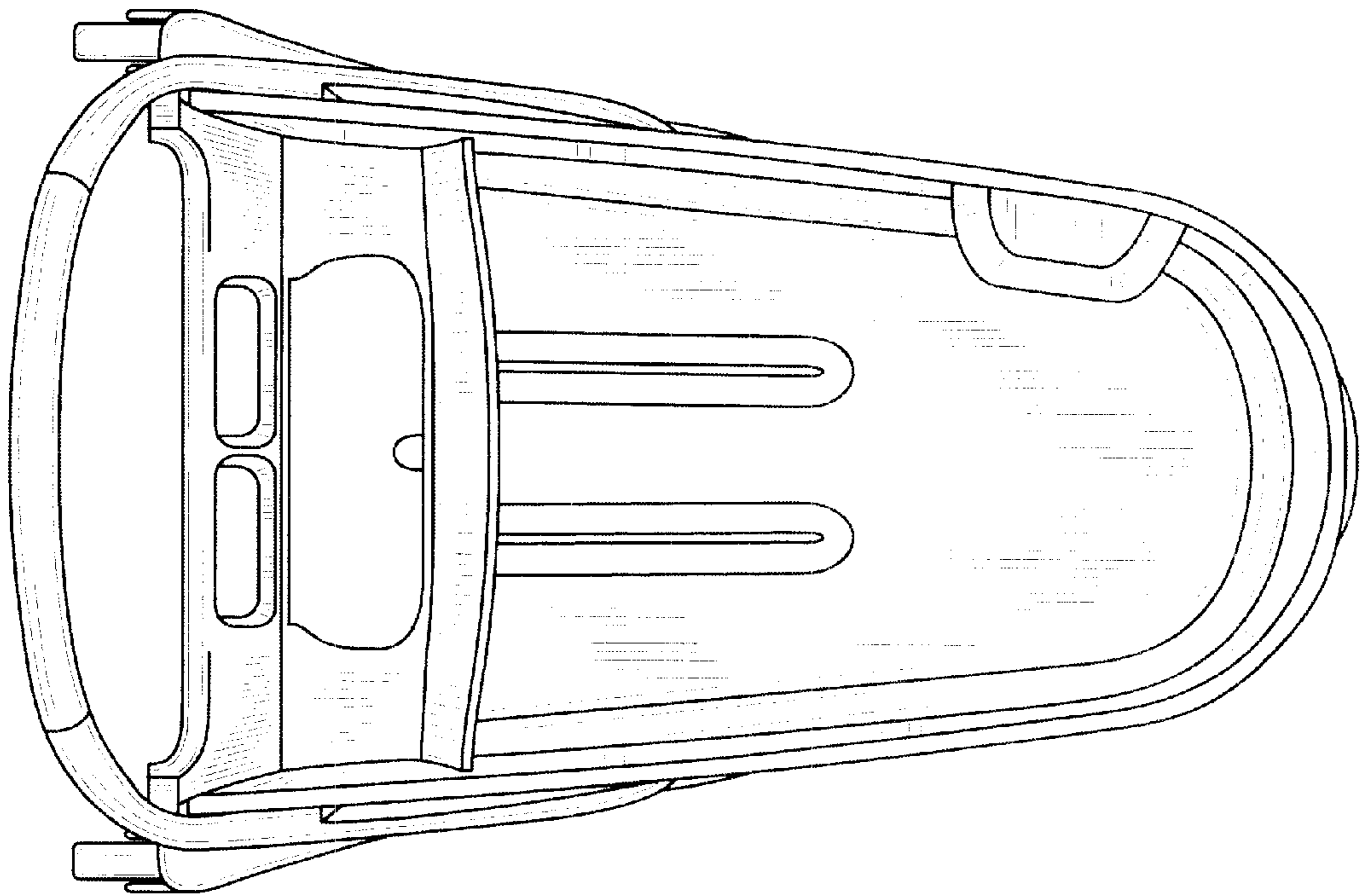

FIG. 5

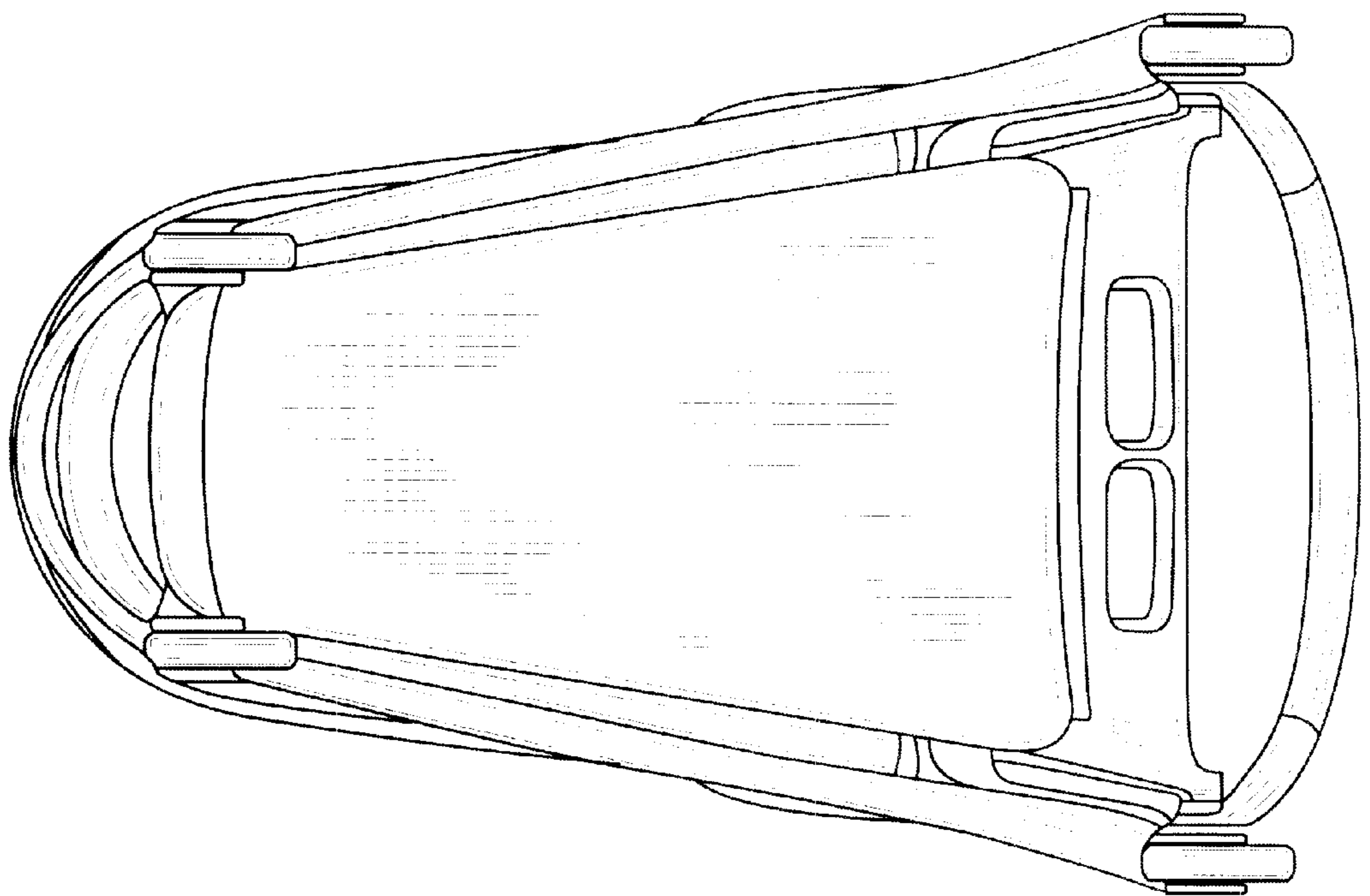

FIG. 6

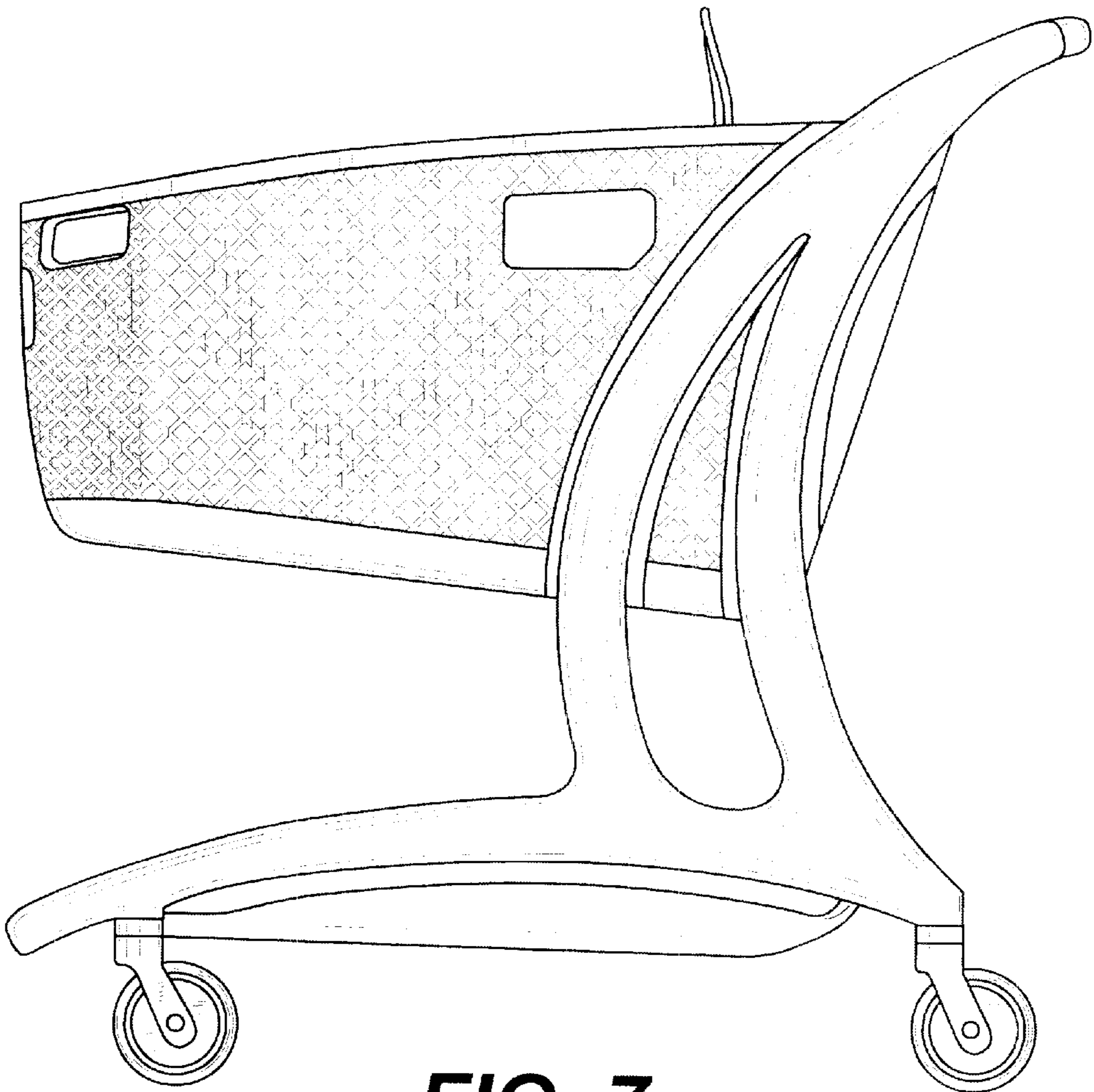

FIG. 7

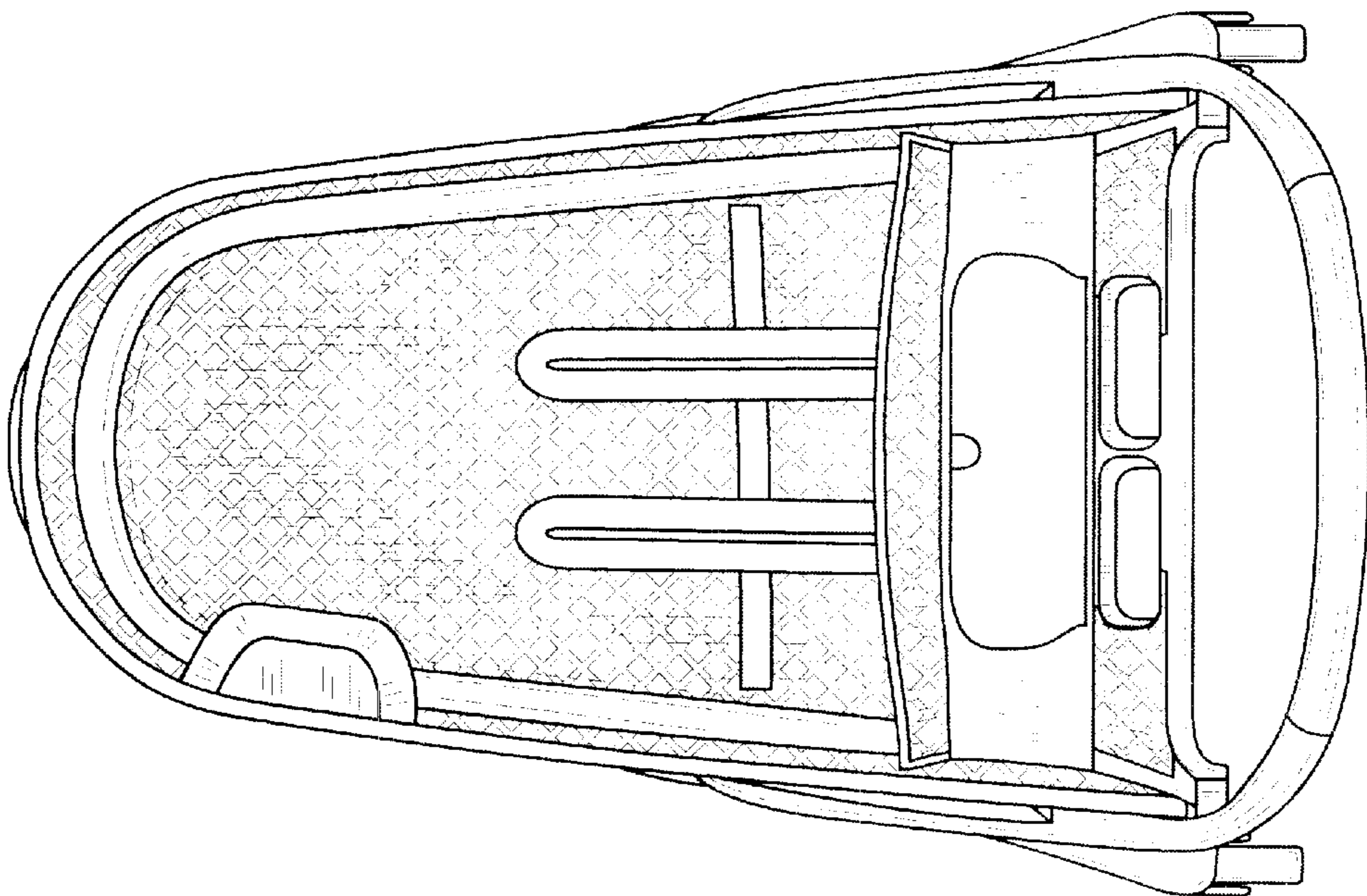

FIG. 8

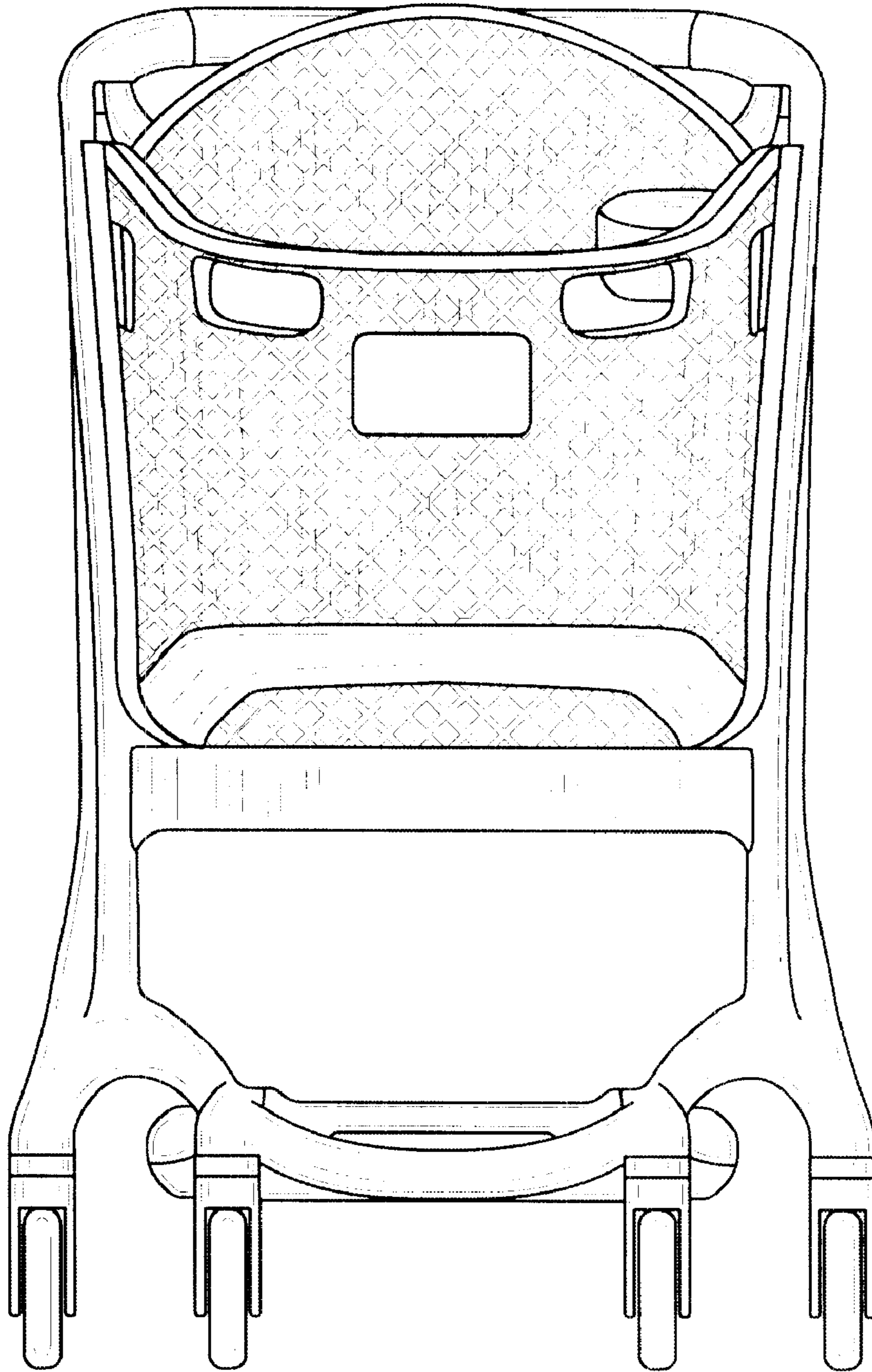

FIG. 9

UNITED STATES PATENT AND TRADEMARK OFFICE
CERTIFICATE OF CORRECTION

PATENT NO. : Des. 470,292 S
DATED : February 11, 2003
INVENTOR(S) : Christopher M. Johnson et al.

Page 1 of 1

It is certified that error appears in the above-identified patent and that said Letters Patent is hereby corrected as shown below:

Title page,
DESCRIPTION, change "expect for" to -- except for --.

Signed and Sealed this

Twenty-fifth Day of March, 2003

A handwritten signature in black ink, appearing to read "James E. Rogan", with a horizontal line drawn underneath it.

JAMES E. ROGAN
Director of the United States Patent and Trademark Office