



US00D470154S

(12) **United States Design Patent**  
**Burmeister et al.**

(10) **Patent No.:** **US D470,154 S**

(45) **Date of Patent:** **\*\* Feb. 11, 2003**

(54) **OUTBOARD MOTOR**

(75) Inventors: **Scott N. Burmeister**, Libertyville, IL (US); **Robert B. Gowens**, Lake Bluff, IL (US); **Peter J. Van Lancker**, Palm City, FL (US); **Christopher F. Deutschmann**, Palm City, FL (US); **Harold L. Wikel, III**, Muskego, WI (US)

(73) Assignee: **Bombardier Motor Corporation of America**, Grant, FL (US)

(\*\*) Term: **14 Years**

(21) Appl. No.: **29/157,825**

(22) Filed: **Mar. 27, 2002**

**Related U.S. Application Data**

(62) Division of application No. 29/122,836, filed on May 4, 2000, now Pat. No. Des. 458,273.

(51) **LOC (7) Cl.** ..... **15-01**

(52) **U.S. Cl.** ..... **D15/4**

(58) **Field of Search** ..... D15/4, 1, 5; 440/3, 440/4, 6, 52, 84, 88, 900; 123/495, 195 P, 195 W; 290/43, 46, 54; 248/642

(56) **References Cited**

**U.S. PATENT DOCUMENTS**

5,830,021 A \* 11/1998 Takahasha et al. .... 440/88

D428,616 S \* 7/2000 Iekura ..... D15/4  
D458,273 S \* 6/2002 Burmeister et al. .... D15/4  
D458,274 S \* 6/2002 Burmeister et al. .... D15/4  
D460,082 S \* 7/2002 Burmeister et al. .... D15/4

\* cited by examiner

*Primary Examiner*—Melody N. Brown  
(74) *Attorney, Agent, or Firm*—Pillsbury Winthrop LLP

(57) **CLAIM**

The ornamental design for a cowling embellishment, as shown and described.

**DESCRIPTION**

FIG. 1 is a perspective view of cowling embellishment in accordance with the present invention.

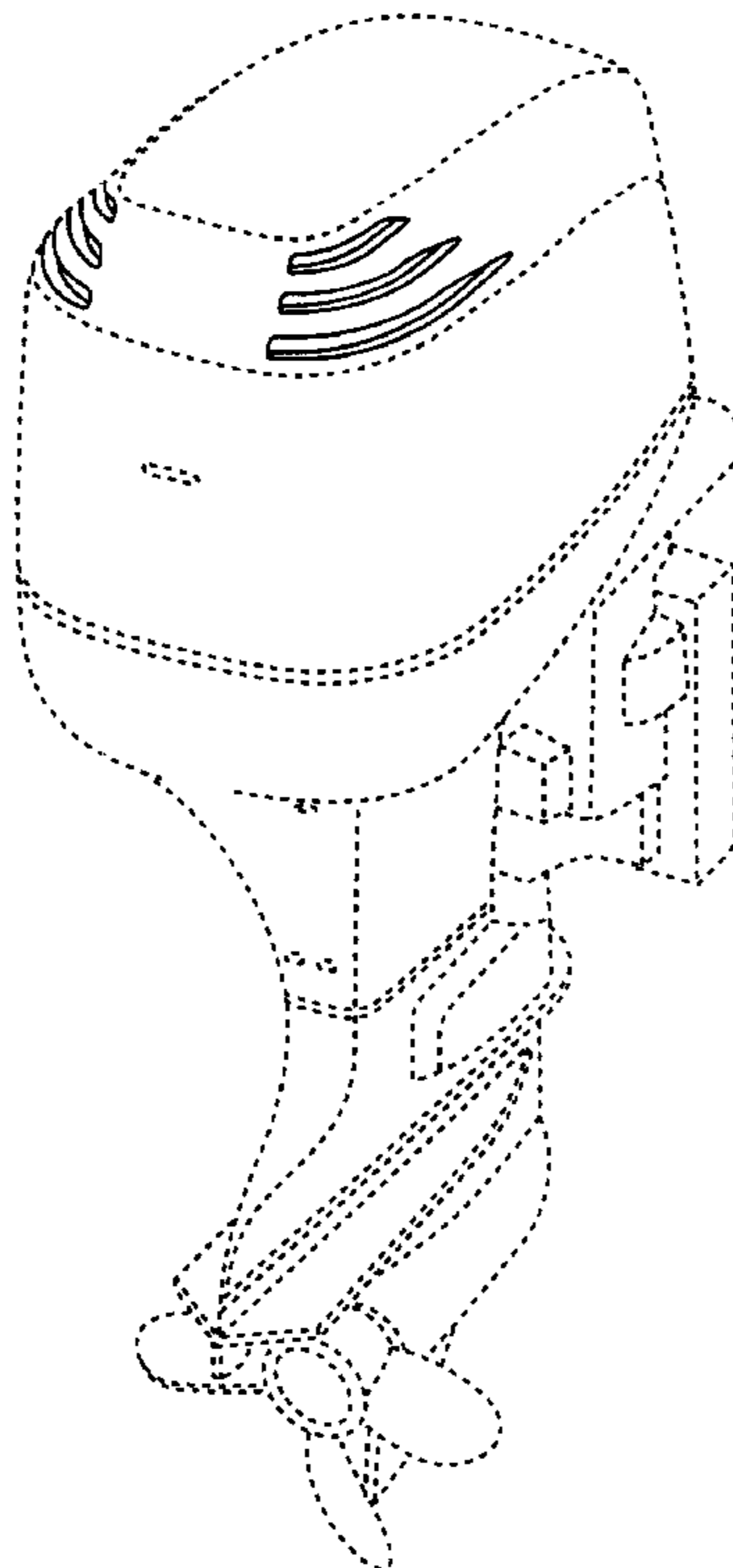
FIG. 2 is the left side view of the cowling embellishment shown in FIG. 1, the right side view being a mirror image thereof.

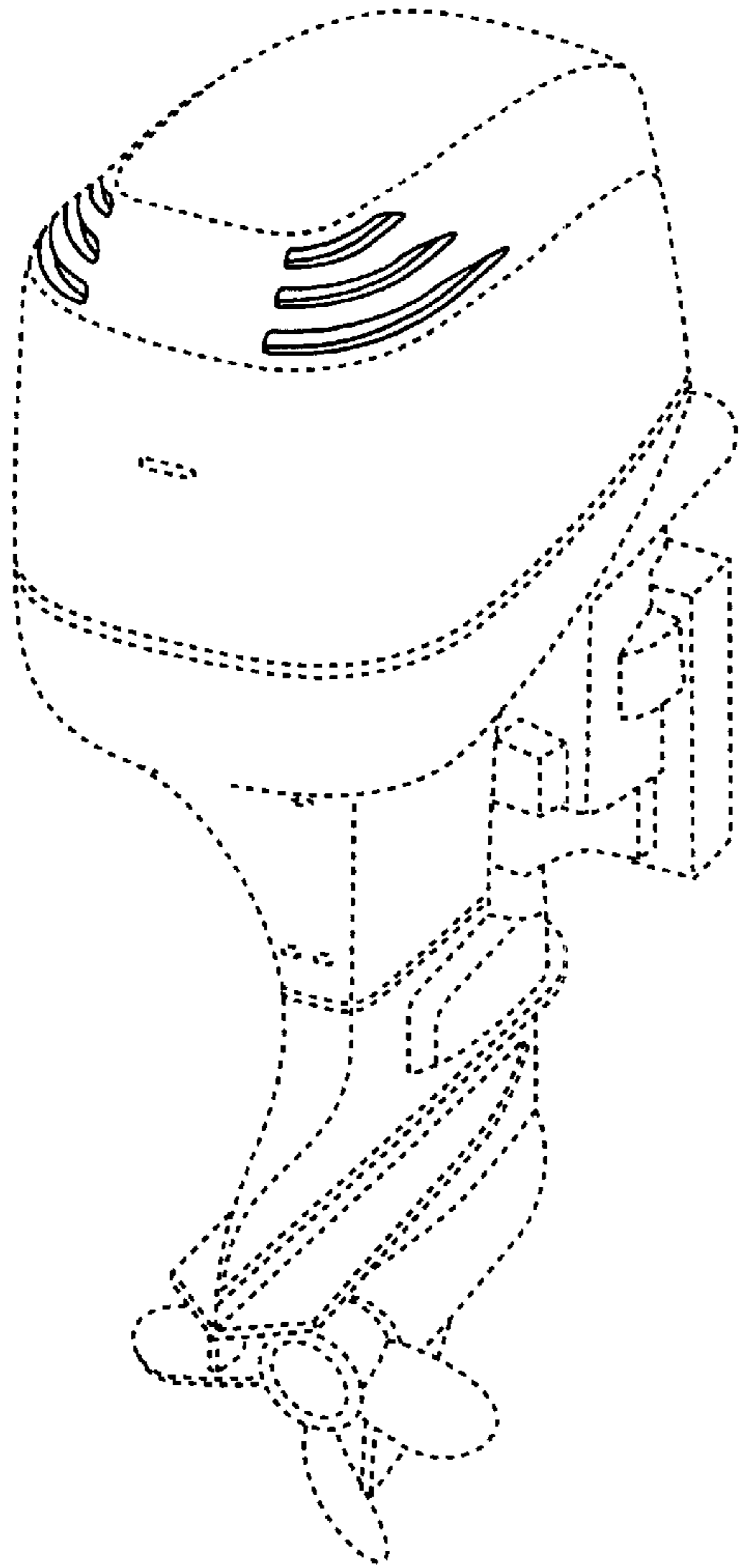
FIG. 3 is a rear view of the cowling embellishment shown in FIG. 1; and,

FIG. 4 is a top view of the cowling embellishment shown in FIG. 1.

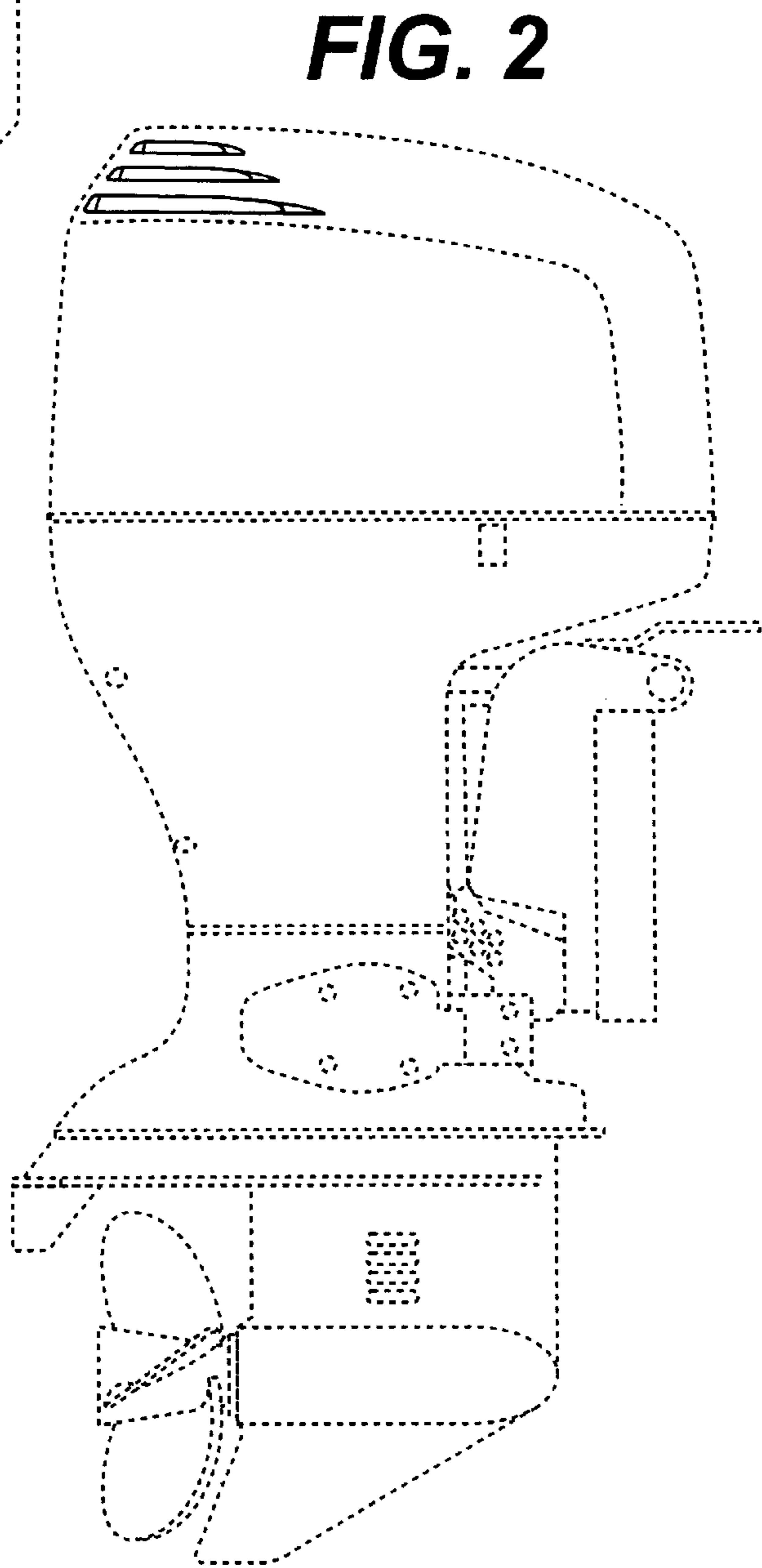
Where included, broken lines showing environment or structure are for illustrative purposes only and form no part of the claimed design.

**1 Claim, 2 Drawing Sheets**

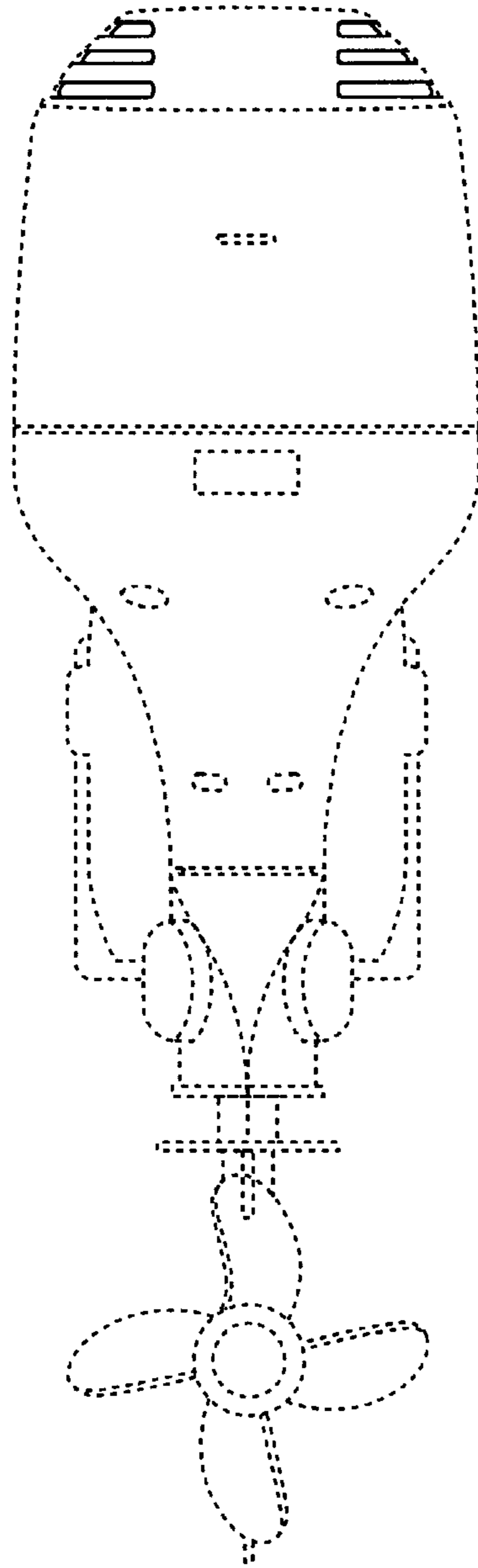




**FIG. 1**



**FIG. 2**



**FIG. 3**

**FIG. 4**

