



US00D469788S

(12) **United States Design Patent**
Mann et al.

(10) **Patent No.:** **US D469,788 S**

(45) **Date of Patent:** **** Feb. 4, 2003**

(54) **COVER FOR WATERJET ASSEMBLY**

(75) Inventors: **Robert J. Mann**, Puyallup, WA (US);
Charles D. Burnham, Southbury, CT (US); **John L. Bushong**, Federal Way, WA (US)

(73) Assignee: **Flow International Corporation**, Kent, WA (US)

(**) Term: **14 Years**

(21) Appl. No.: **29/147,331**

(22) Filed: **Aug. 27, 2001**

(51) **LOC (7) Cl.** **15-09**

(52) **U.S. Cl.** **D15/127; D15/199**

(58) **Field of Search** D15/199, 127;
83/53, 170, 171, 177; 451/40, 91, 102,
38, 39, 75; 239/596, 589, 590, 591, 600,
DIG. 19

(56) **References Cited**

U.S. PATENT DOCUMENTS

5,848,753 A * 12/1998 Wands et al. 239/596

* cited by examiner

Primary Examiner—Antoine Duval Davis

(74) *Attorney, Agent, or Firm*—Seed Intellectual Property Law Group PLLC

(57) **CLAIM**

The ornamental design for a cover for waterjet assembly, as shown and described.

DESCRIPTION

FIG. 1 is a front elevational view of a cover for waterjet assembly showing a first embodiment of our new design. FIG. 2 is a rear perspective view thereof. FIG. 3 is a left side elevational view thereof, the right side elevational view being symmetrical. FIG. 4 is a rear elevational view thereof. FIG. 5 is a top plan view thereof. FIG. 6 is a bottom plan view thereof. FIG. 7 is a front elevational view of a cover for waterjet assembly showing a second embodiment of our new design. FIG. 8 is a rear perspective view thereof. FIG. 9 is a left side elevational view thereof, the right side elevational view being symmetrical. FIG. 10 is a rear elevational view thereof. FIG. 11 is a top plan view thereof. FIG. 12 is a bottom plan view thereof. FIG. 13 is a front elevational view of a cover for waterjet assembly showing a third embodiment of our new design. FIG. 14 is a left side elevational view thereof, the right side elevational view being symmetrical. FIG. 15 is a rear elevational view thereof. FIG. 16 is a top plan view thereof; and, FIG. 17 is a bottom plan view thereof. The broken lines in FIG. 15 are for illustrative purposes only and form no part of the claimed design.

1 Claim, 9 Drawing Sheets

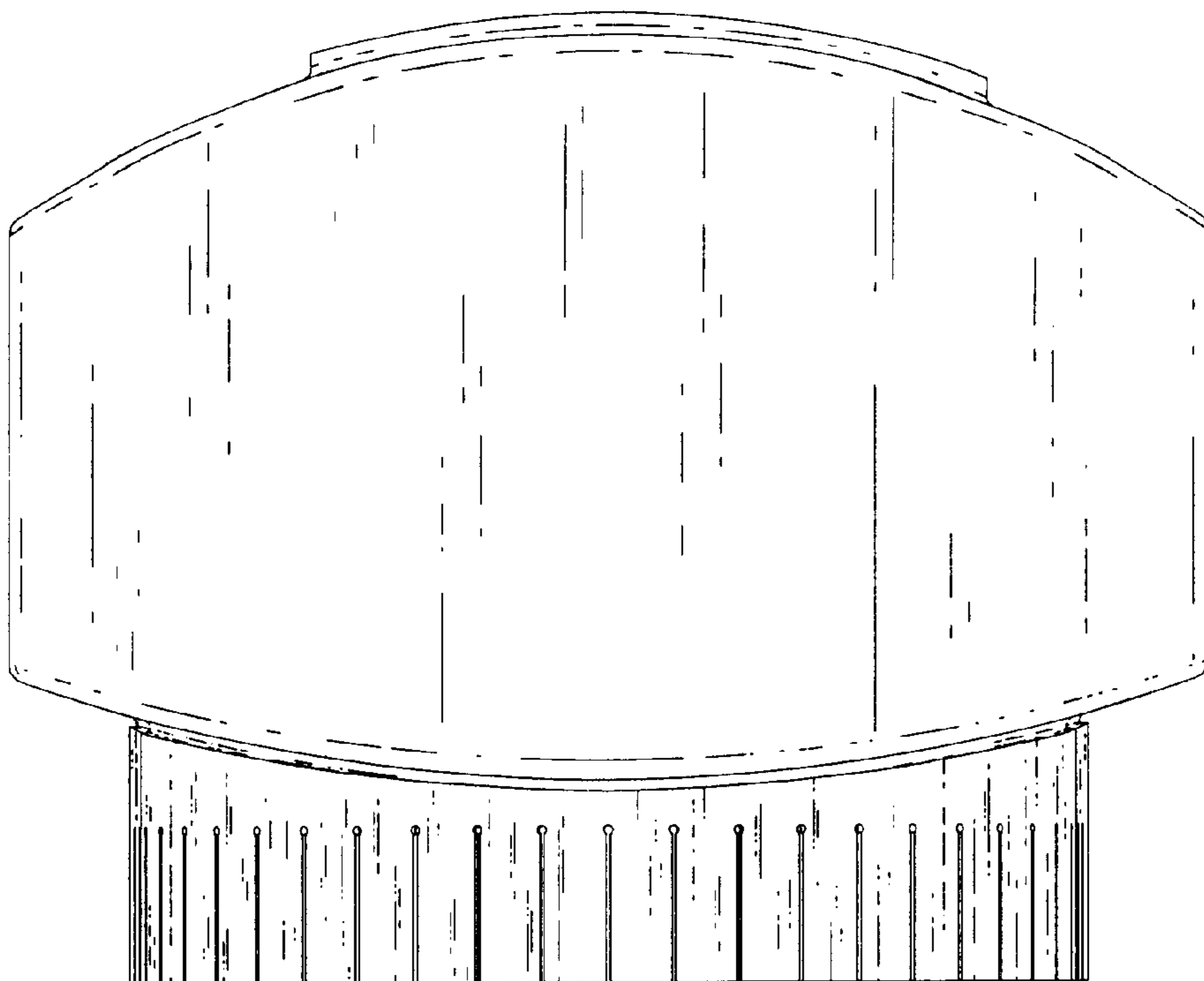

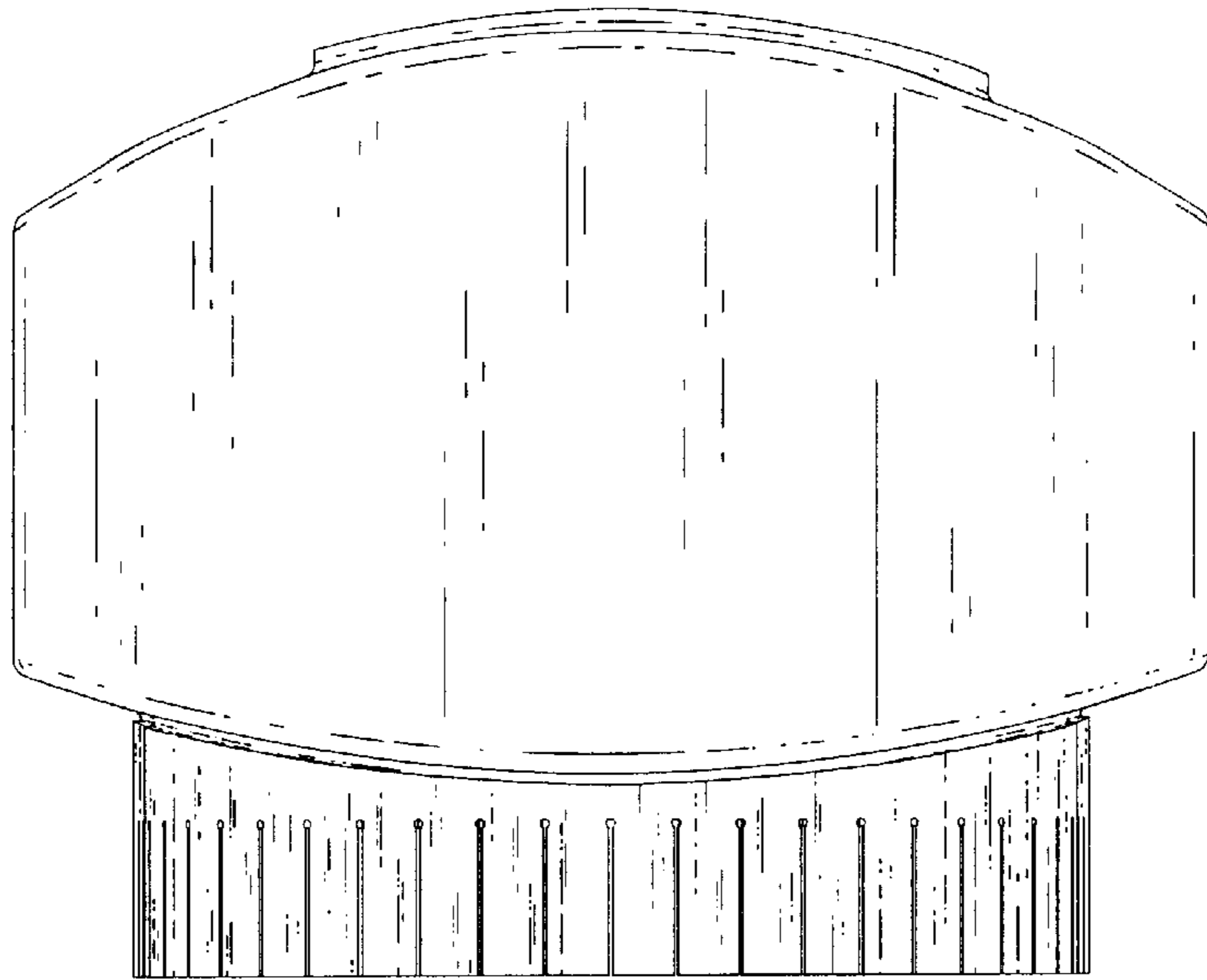

Fig. 1

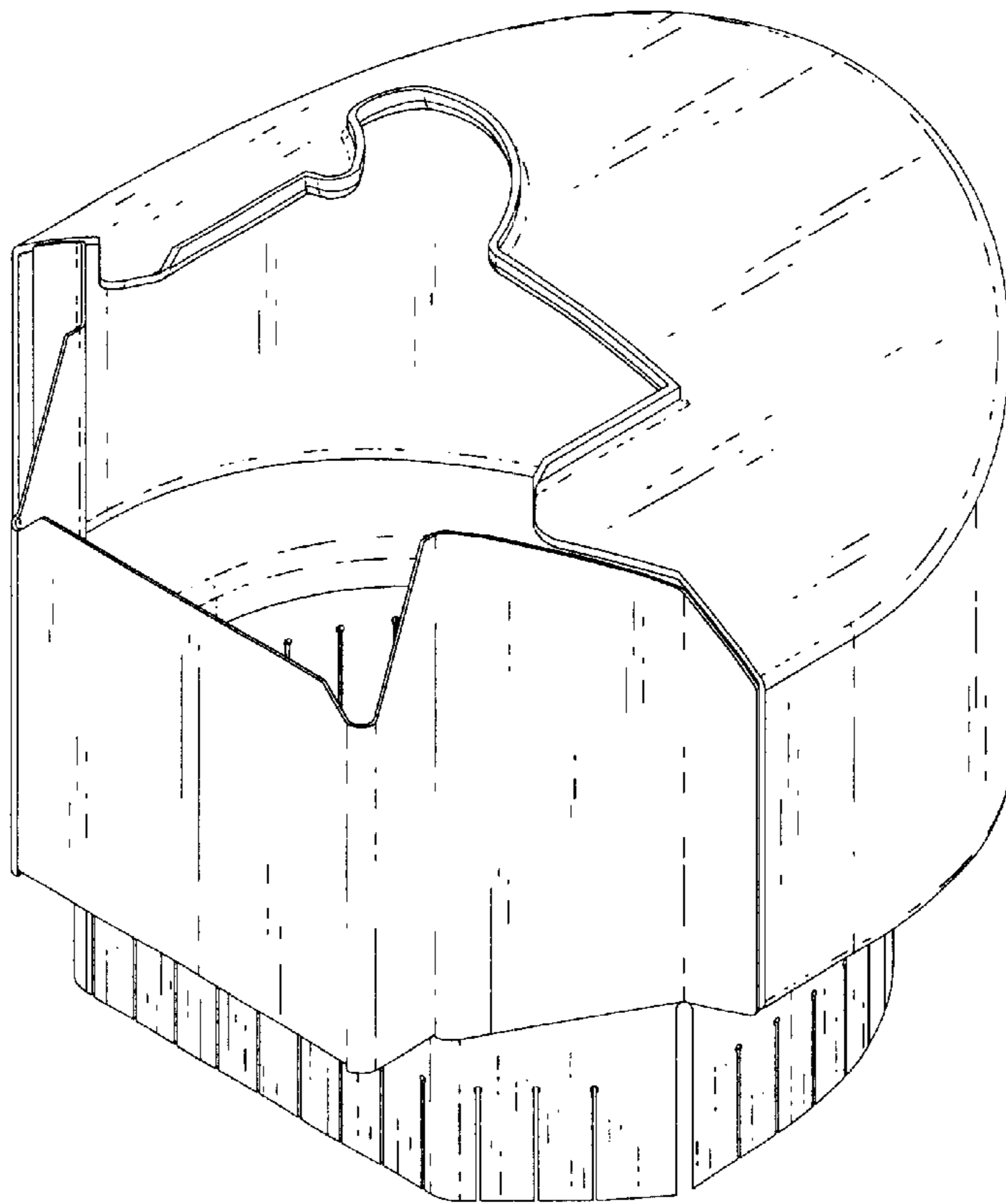

Fig. 2

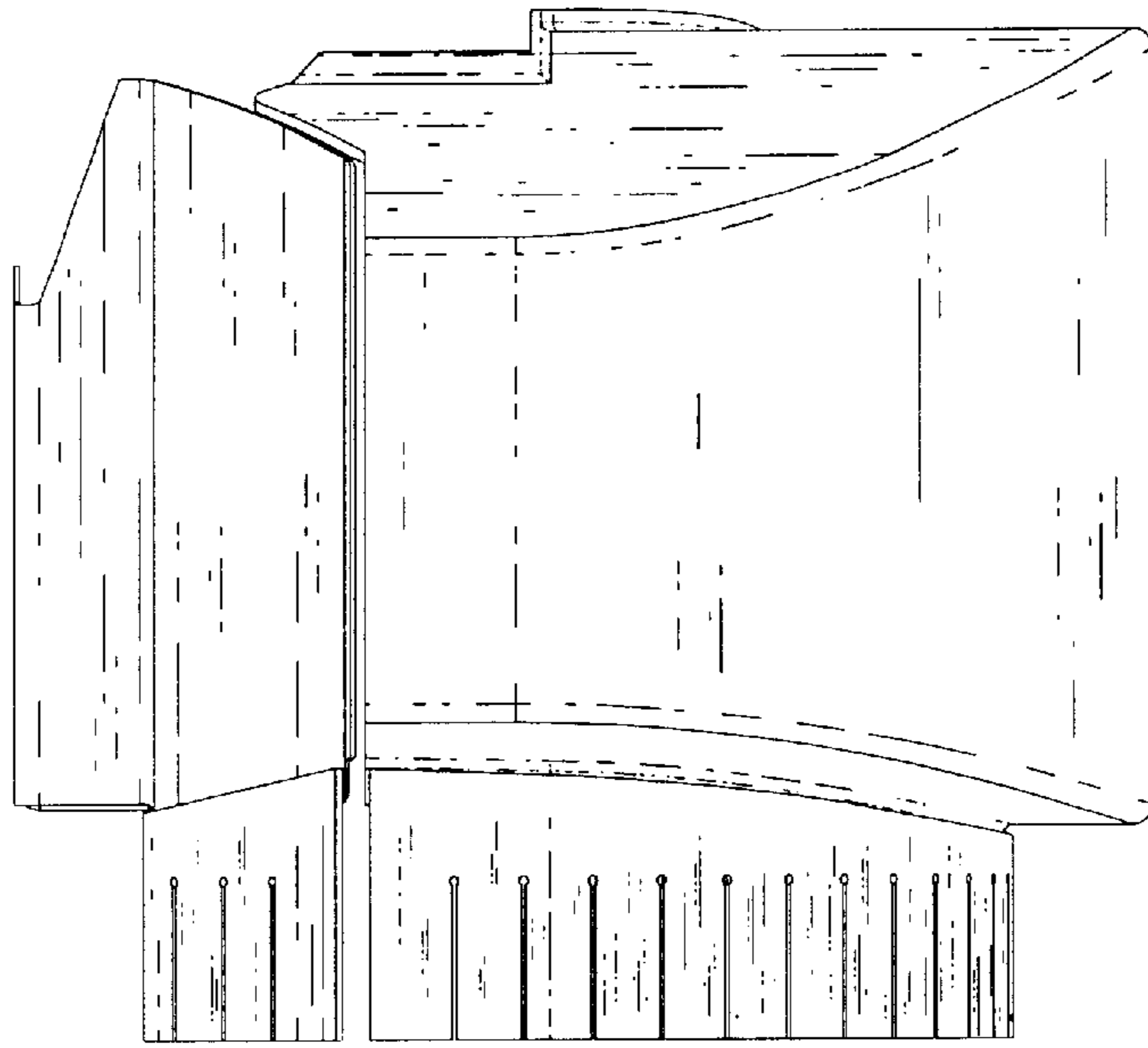

Fig. 3

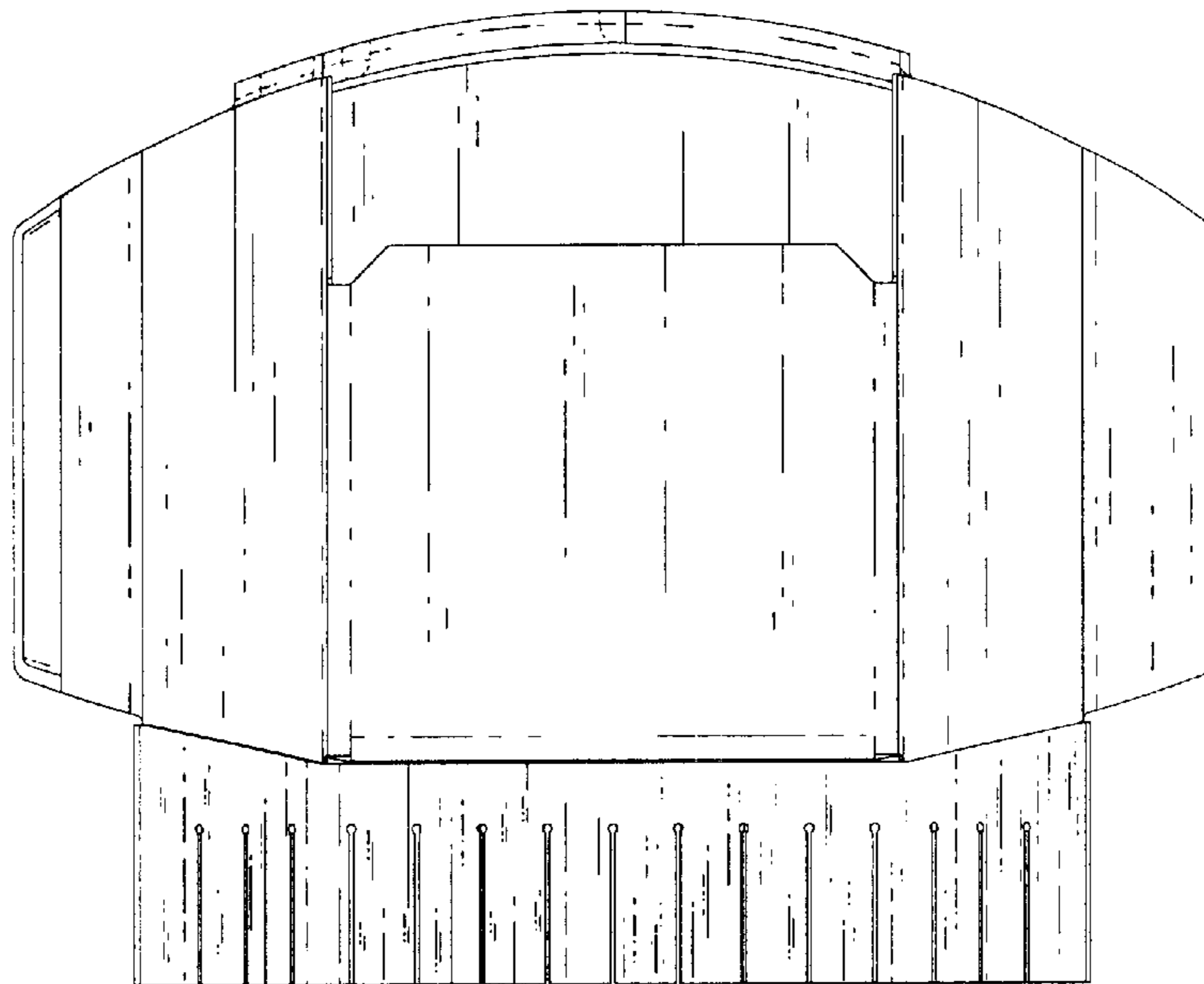

Fig. 4

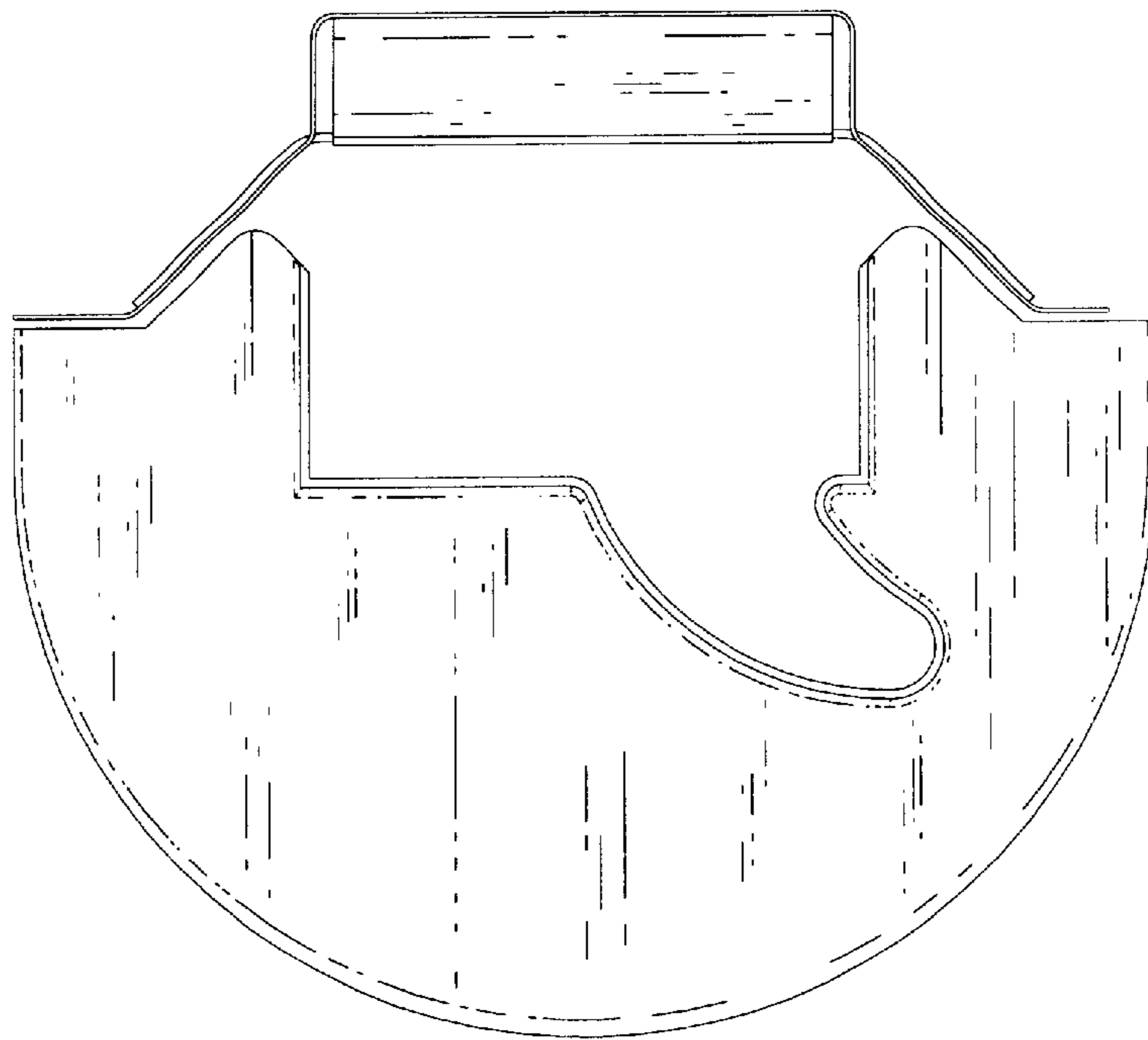

Fig. 5

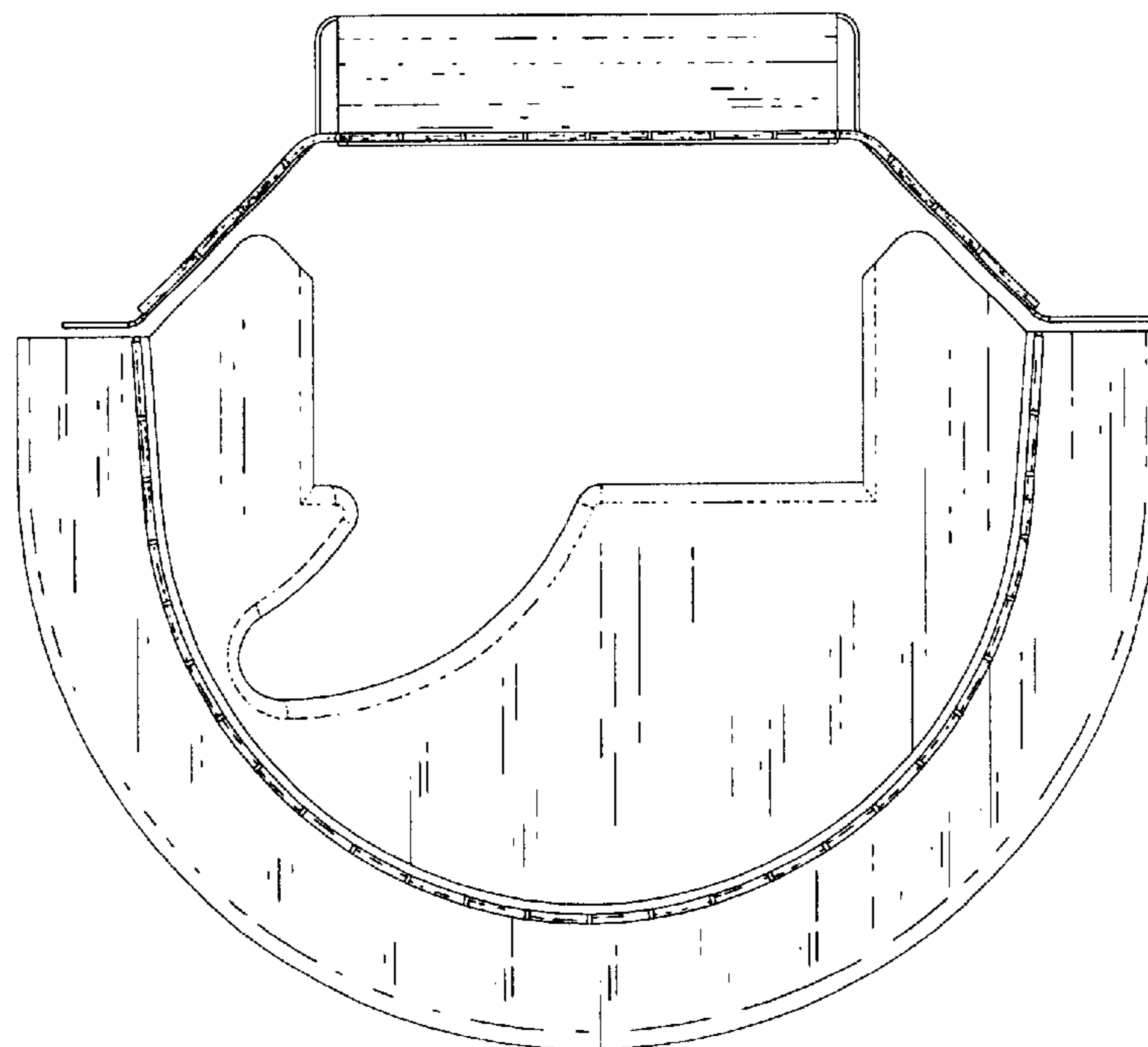

Fig. 6

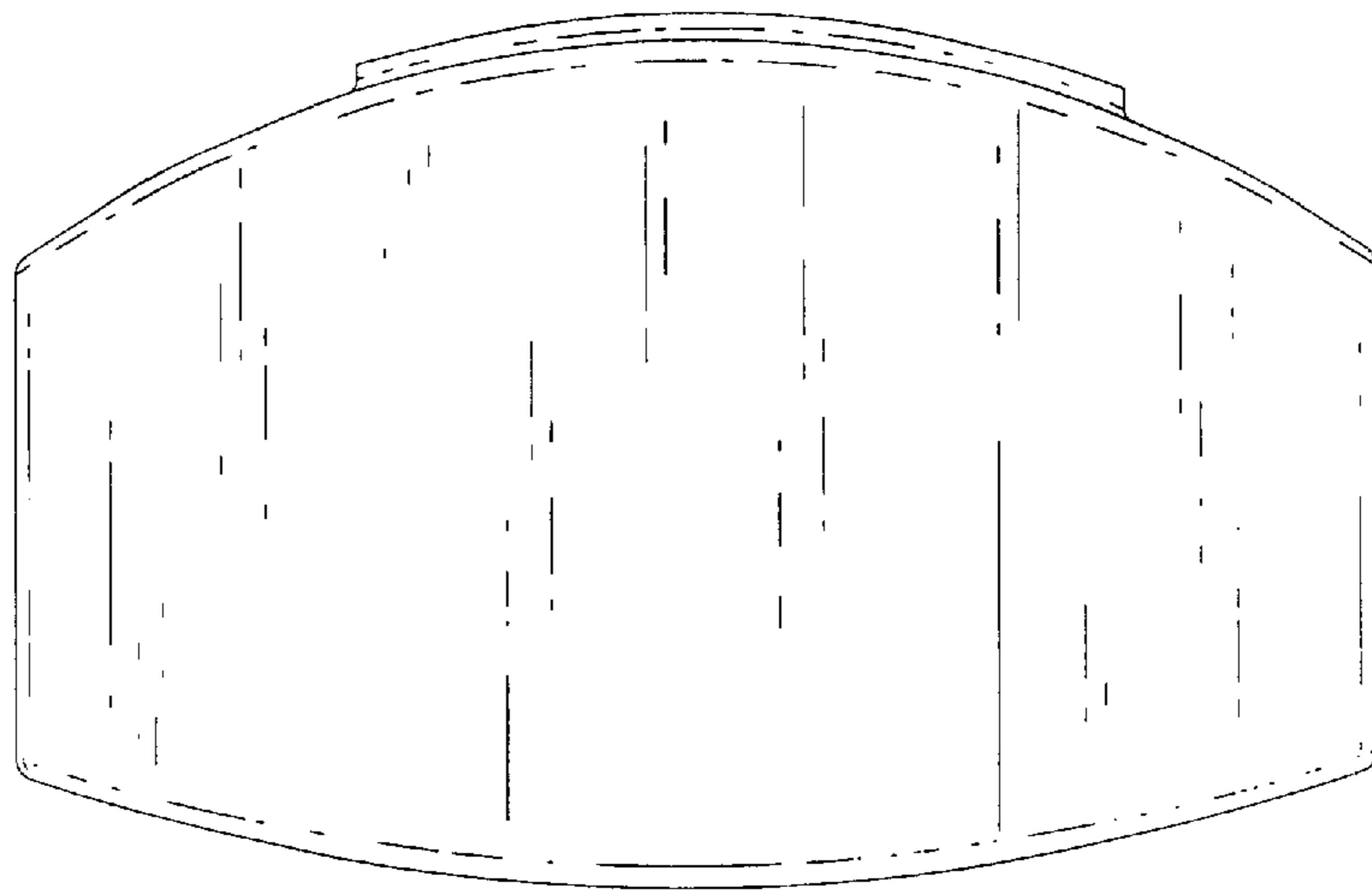

Fig. 7

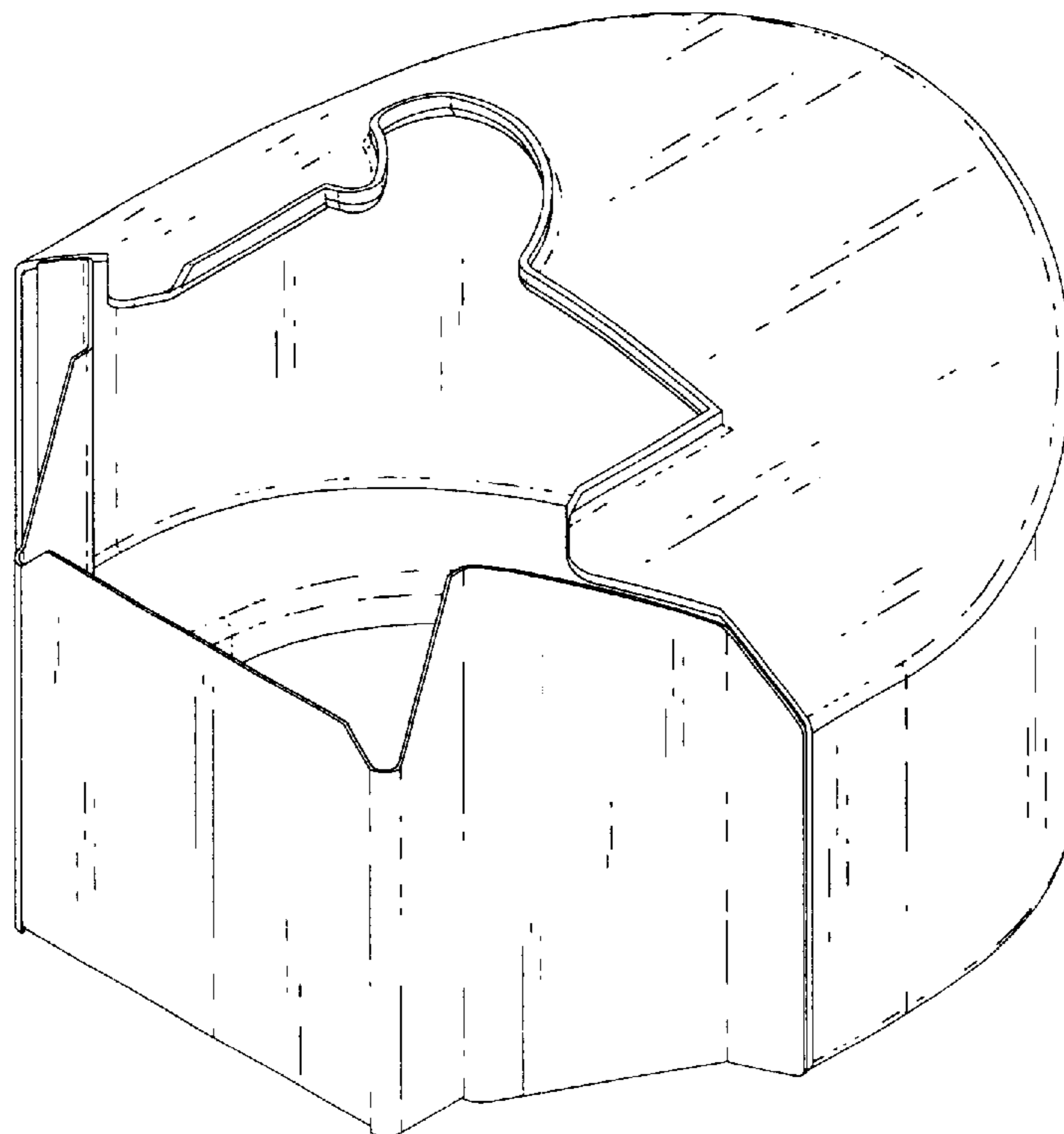

Fig. 8

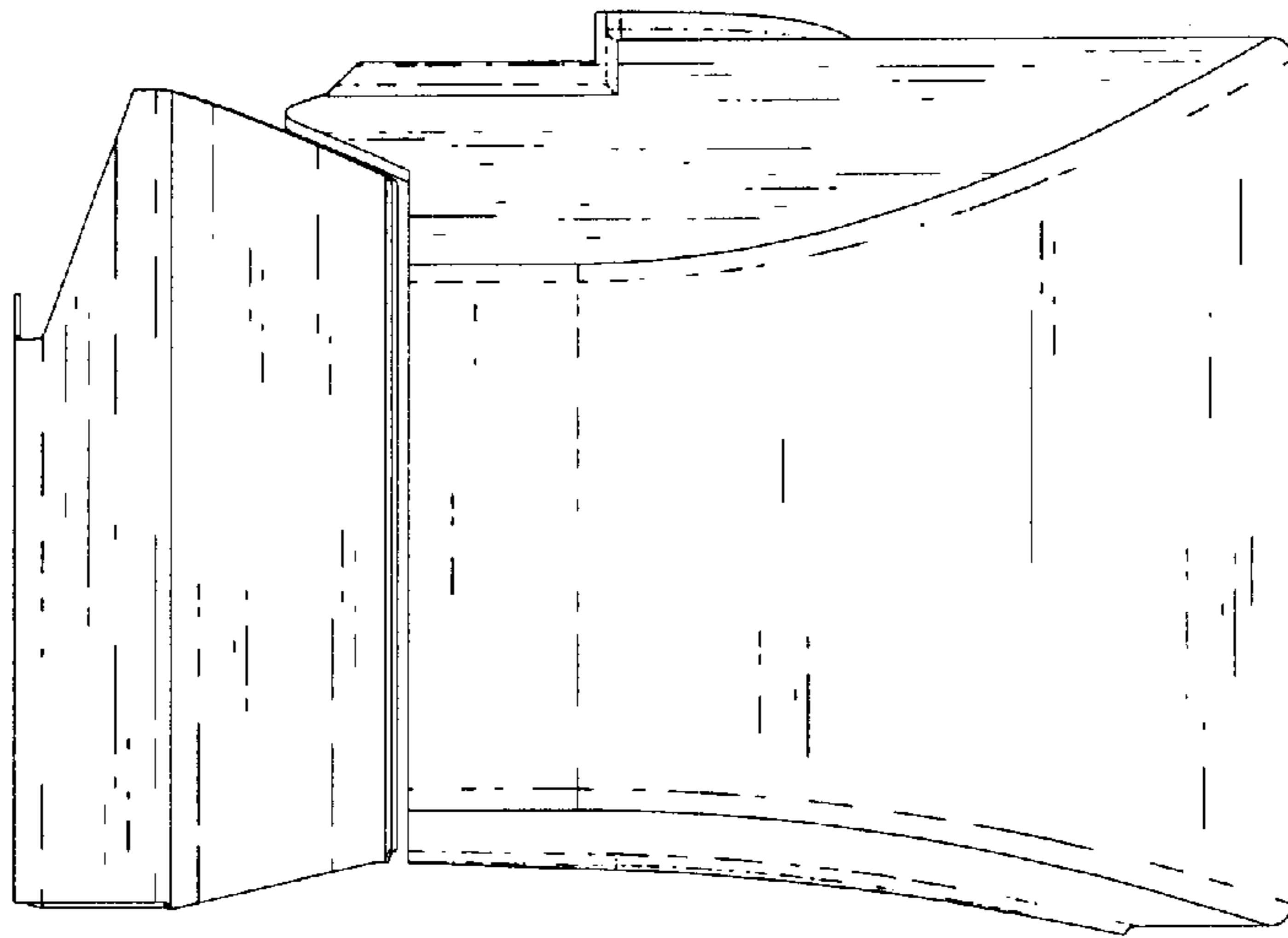

Fig. 9

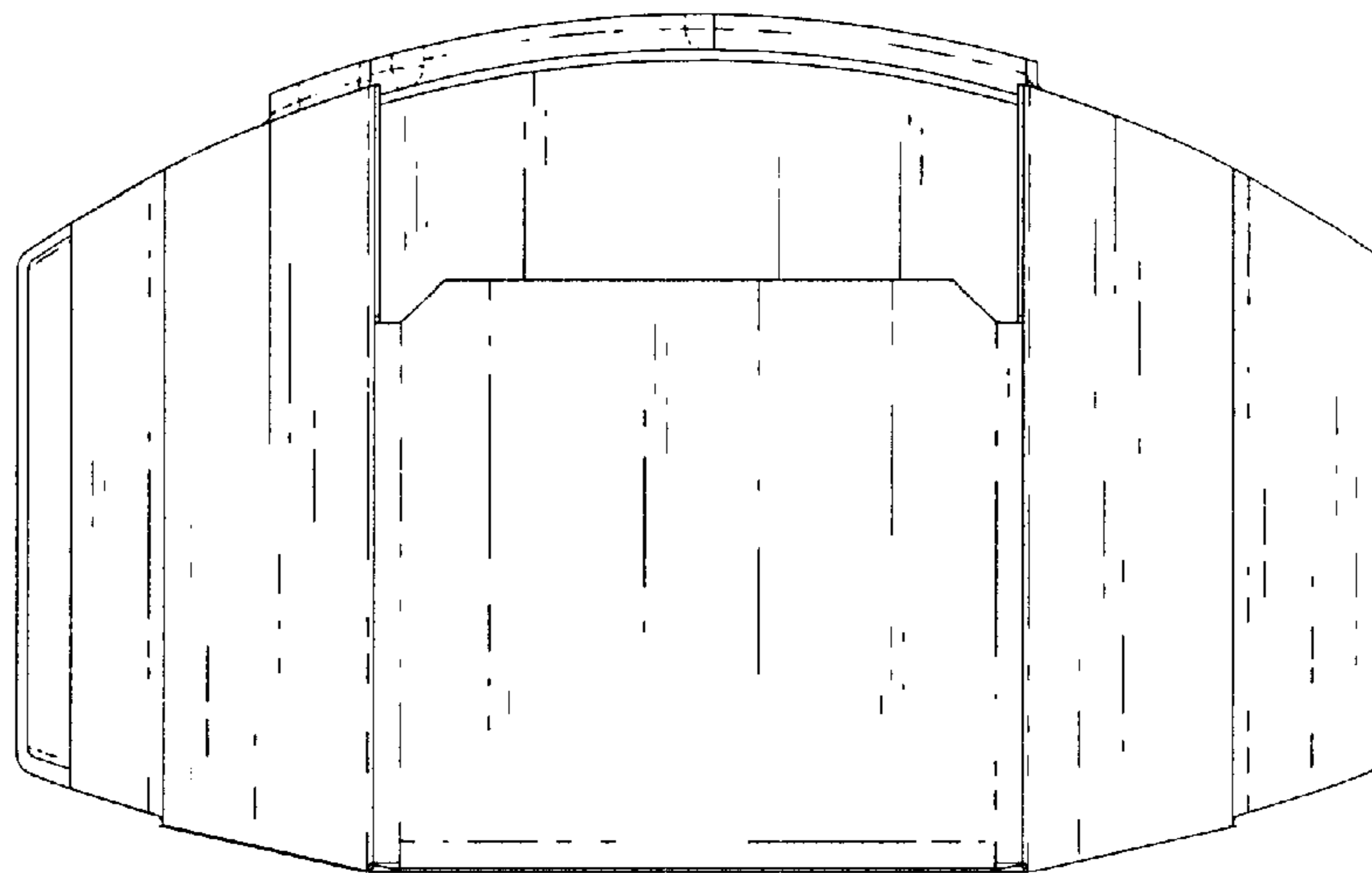

Fig. 10

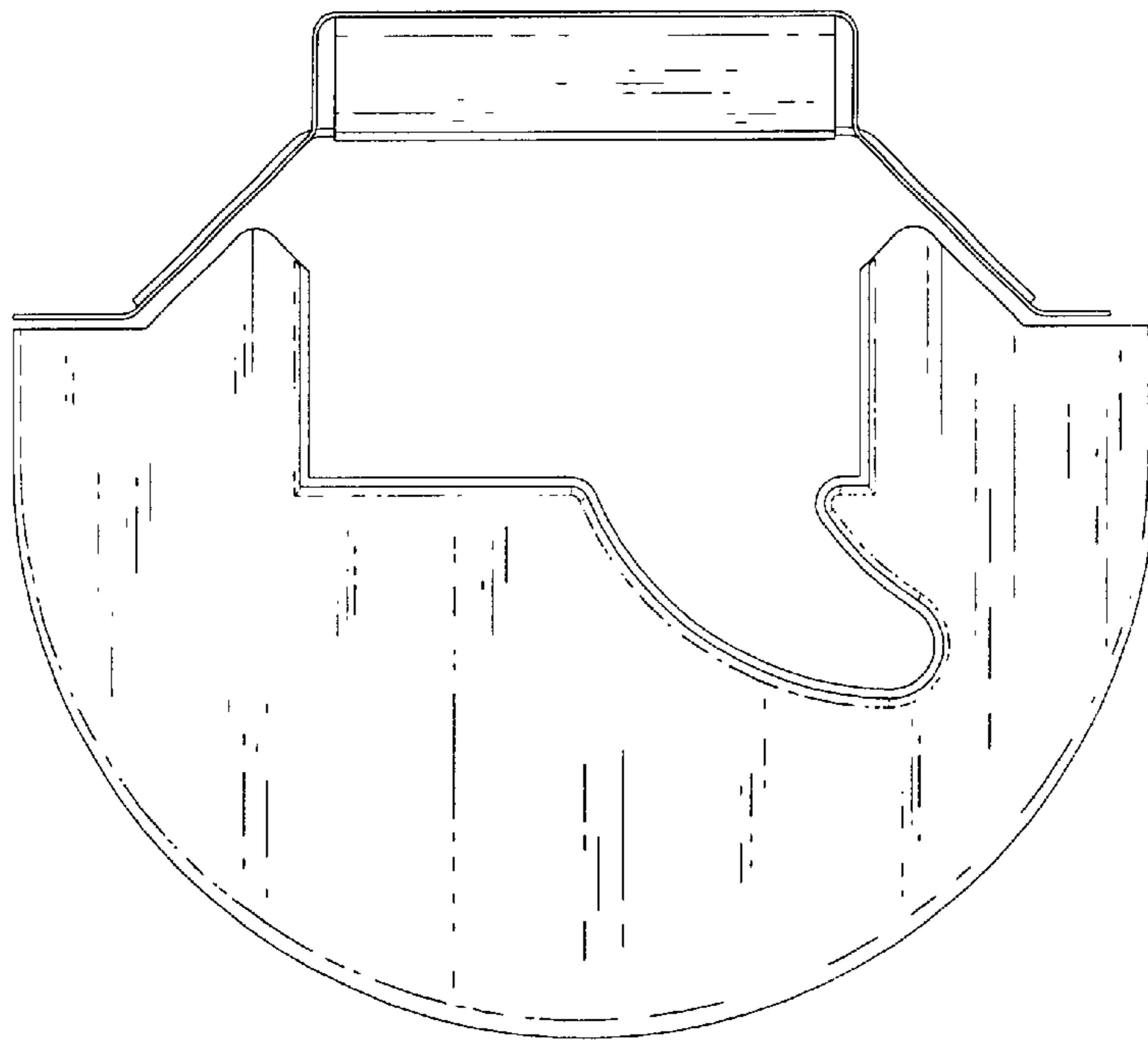

Fig. 11

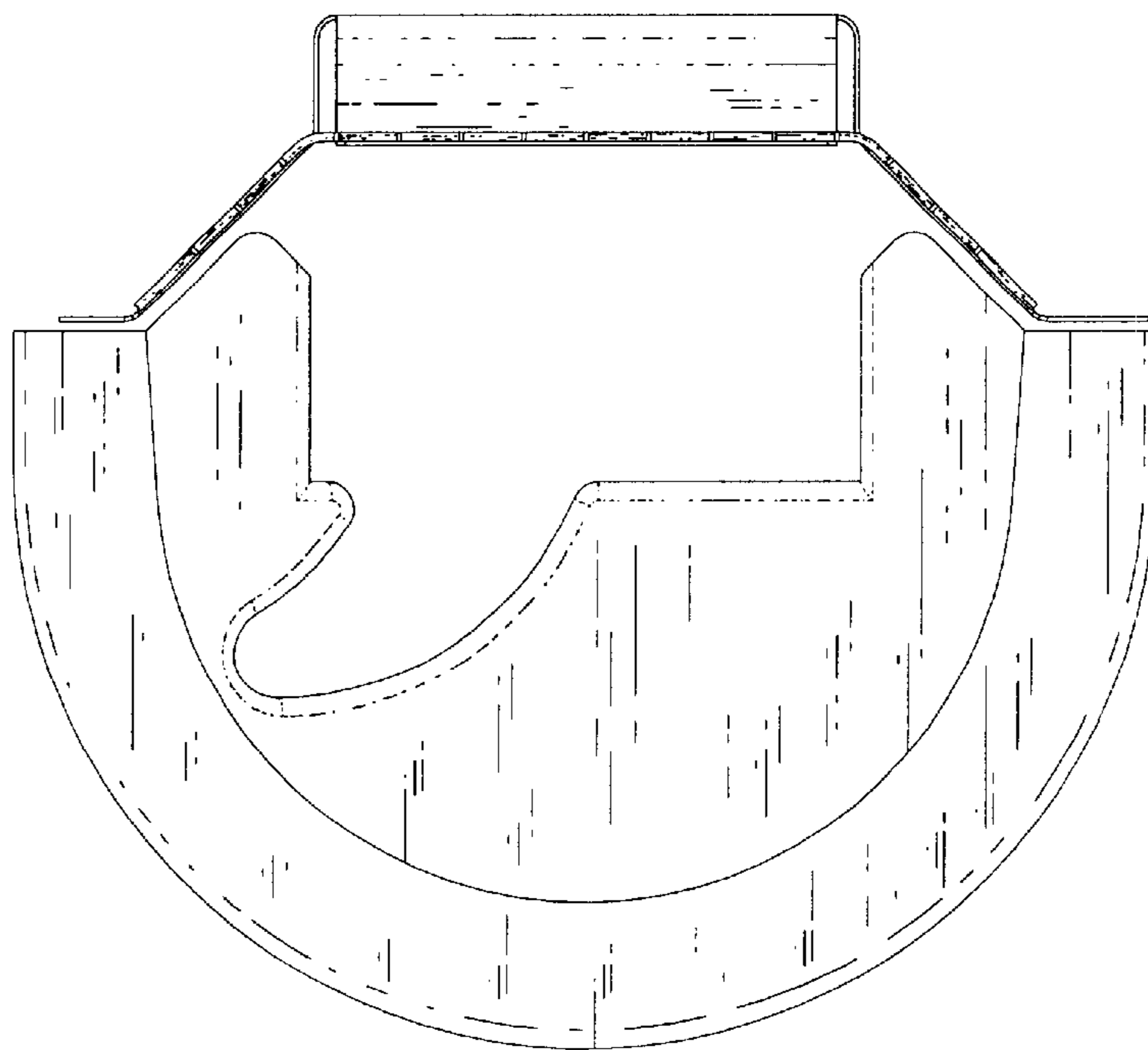

Fig. 12

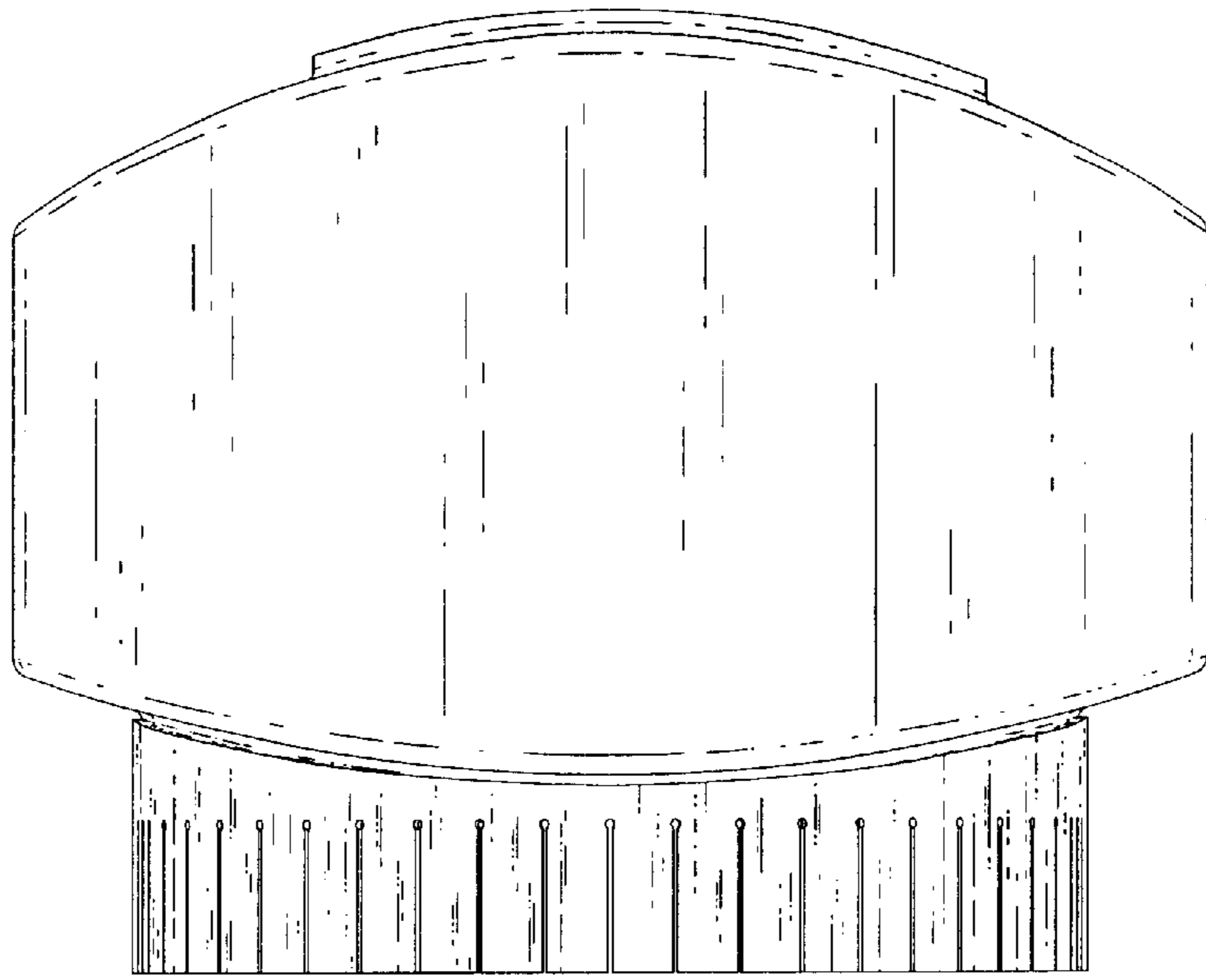

Fig. 13

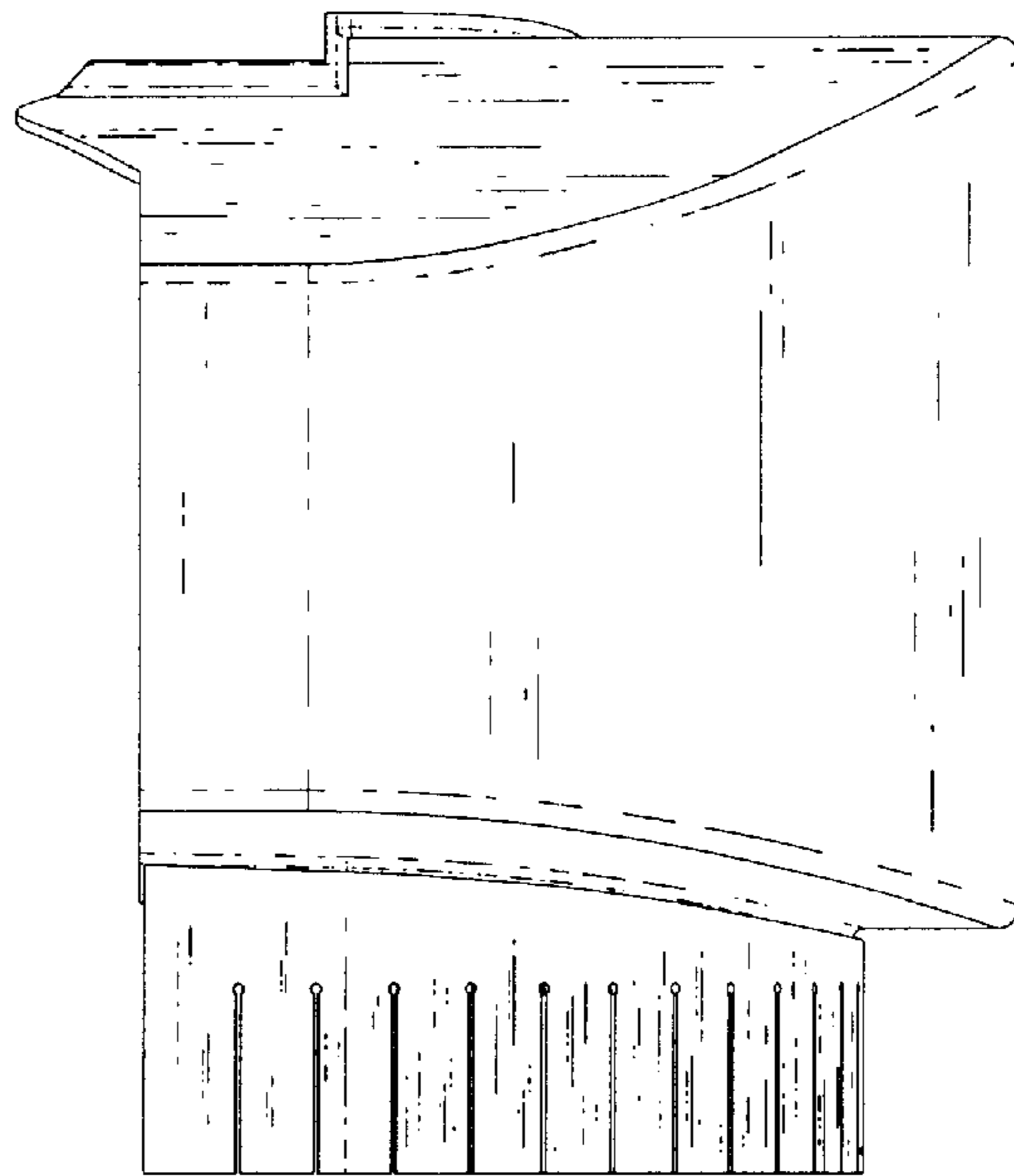

Fig. 14

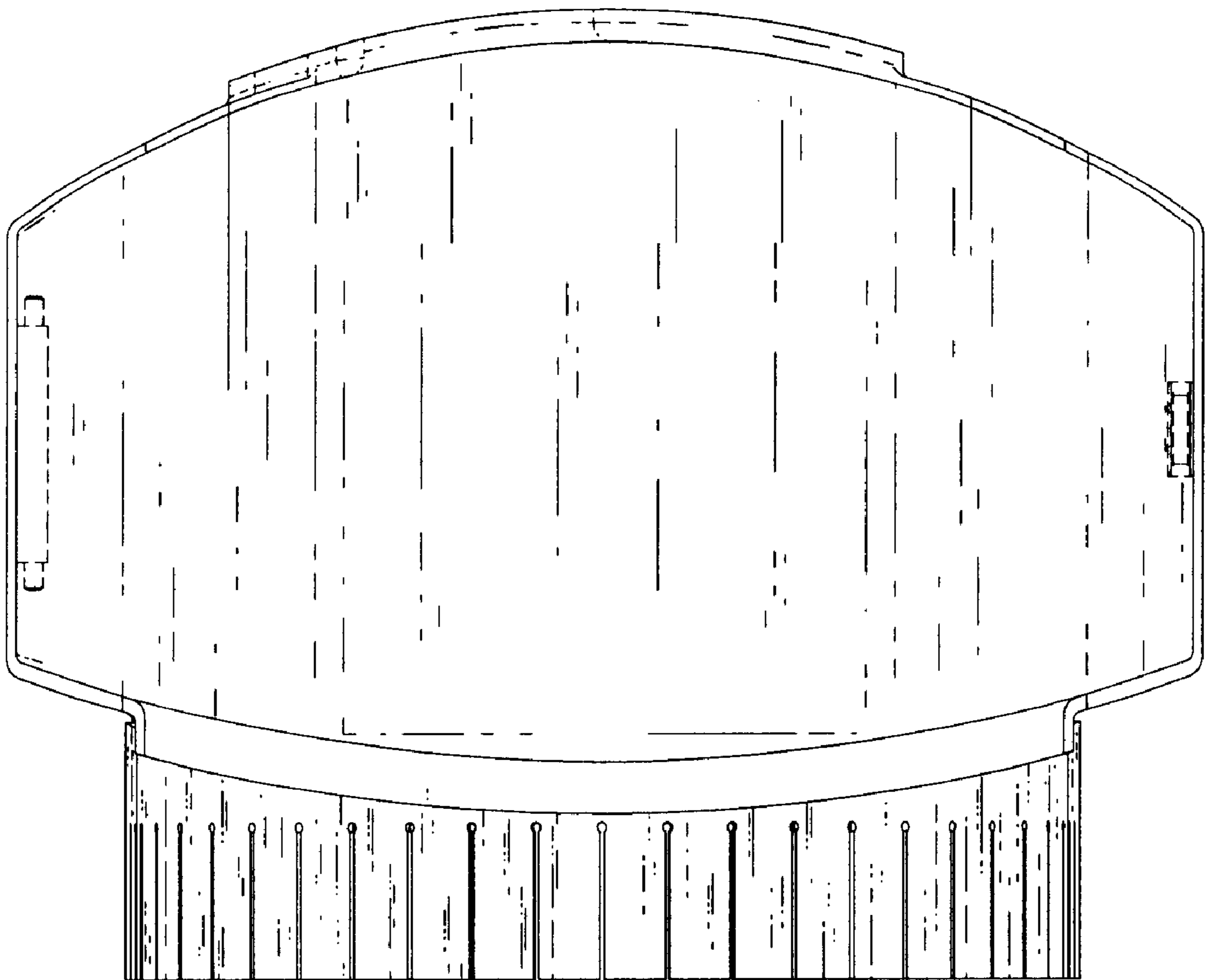

Fig. 15

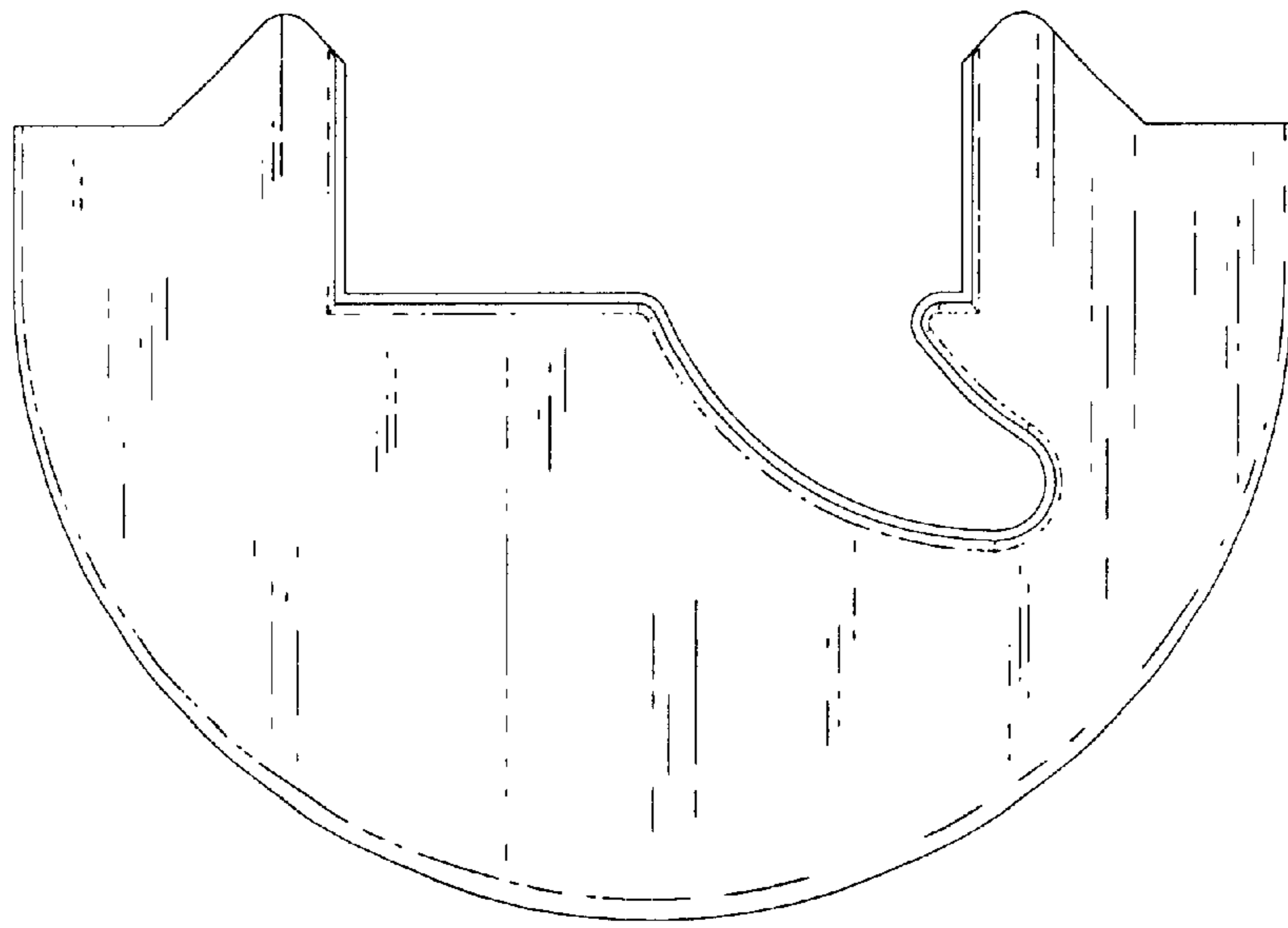

Fig. 16

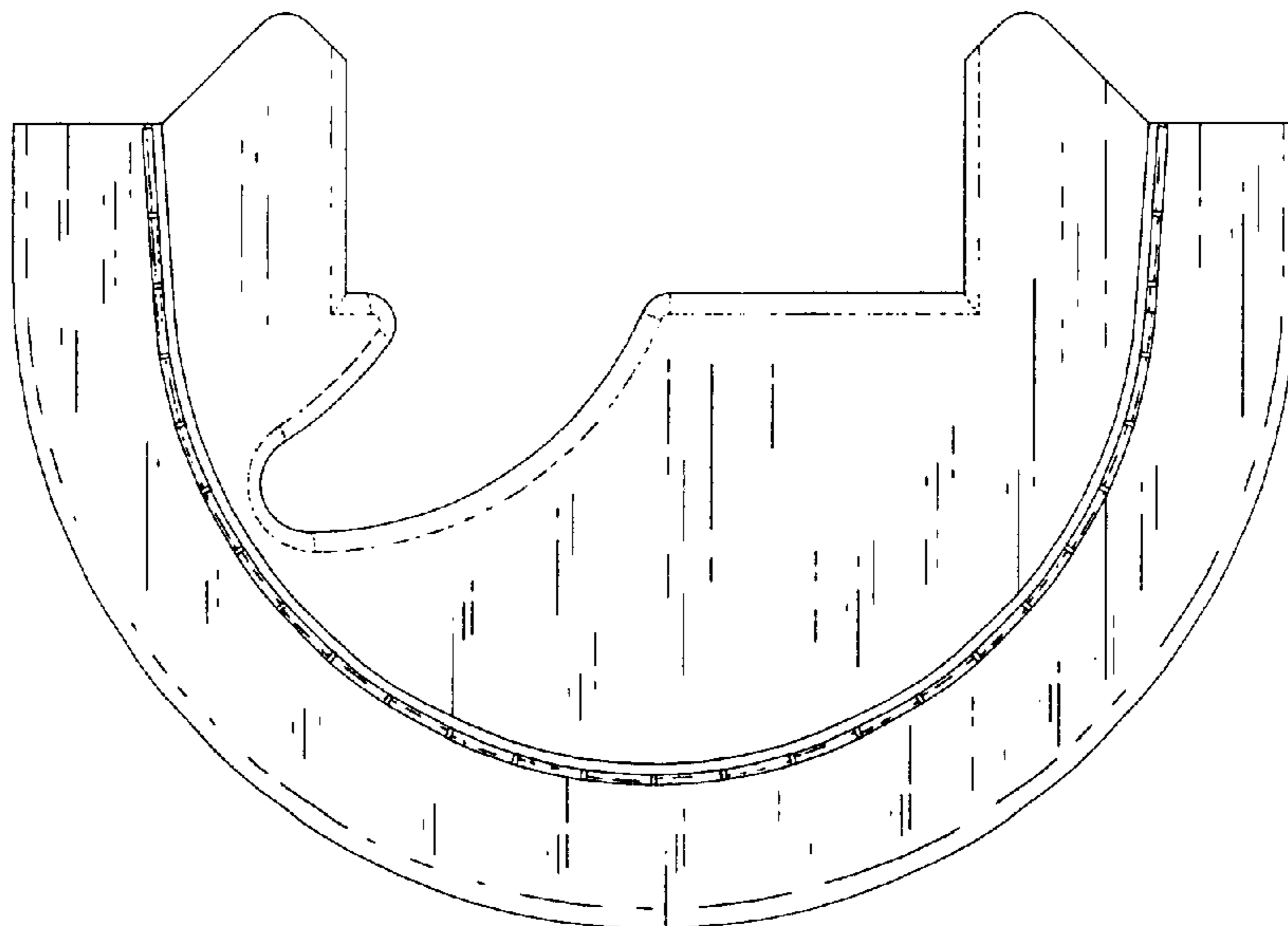

Fig. 17