



US00D469675S

(12) **United States Design Patent**
Chung

(10) **Patent No.:** **US D469,675 S**

(45) **Date of Patent:** **** Feb. 4, 2003**

(54) **CORDLESS DRILL**

(75) **Inventor:** **Godfrey Ka Wai Chung, Chung UK**
Tsuen (HK)

(73) **Assignee:** **One World Technologies Limited,**
Hamilton (BM)

(**) **Term:** **14 Years**

(21) **Appl. No.:** **29/151,751**

(22) **Filed:** **Dec. 7, 2001**

(51) **LOC (7) Cl.** **08-01**

(52) **U.S. Cl.** **D8/68**

(58) **Field of Search** D8/61, 62, 63,
D8/64, 65, 66, 67, 68, 69, 70; 81/57.11,
429, 464, 465, 466, 469, 489; 173/13, 169,
178, 213, 217; 227/8, 114, 120, 130, 136,
142; 310/50; 408/20, 124, 125, 234, 241 R;
451/358

D419,413 S	1/2000	Heun	
D420,879 S	2/2000	Watson et al.	
D421,883 S	3/2000	Watson et al.	
6,045,303 A	4/2000	Chung	
D428,320 S	7/2000	Ohi et al.	
D429,134 S	8/2000	Schultz et al.	
D435,414 S	12/2000	Etter et al.	
D436,511 S	1/2001	Hayakawa et al.	
D437,759 S	* 2/2001	Breit et al. D8/68
6,308,378 B1	10/2001	Mooty et al.	
6,364,580 B1	* 4/2002	Dils et al. 408/241 R
D460,673 S	* 7/2002	Heun D8/68
D460,674 S	* 7/2002	Heun D8/68

* cited by examiner

Primary Examiner—Doris V. Coles

Assistant Examiner—T. Chase Nelson

(74) *Attorney, Agent, or Firm*—Brooks & Kushman P.C.

(57) **CLAIM**

The ornamental design for a cordless drill, as shown and described.

DESCRIPTION

FIG. 1 is a perspective view of a cordless drill;
FIG. 2 is a left side elevational view thereof;
FIG. 3 is a right side elevational view thereof;
FIG. 4 is a front elevational view thereof;
FIG. 5 is a rear elevational view thereof;
FIG. 6 is a top plan view thereof; and,
FIG. 7 is a bottom plan view of the present invention.
No claim is made to the portions of the cordless drill
illustrated in phantom outline.

1 Claim, 3 Drawing Sheets

(56) **References Cited**

U.S. PATENT DOCUMENTS

D326,598 S	6/1992	Sakamoto et al.	
D377,442 S	* 1/1997	Kikuchi D8/68
D378,268 S	* 3/1997	Schultz D8/68
5,640,741 A	6/1997	Yano	
D382,457 S	* 8/1997	Ghode et al. D8/68
D386,662 S	* 11/1997	Tozawa et al. D8/68
5,690,451 A	11/1997	Thurler et al.	
D402,871 S	* 12/1998	Clowers et al. D8/68
D409,467 S	5/1999	Chung	
D418,730 S	1/2000	Main	

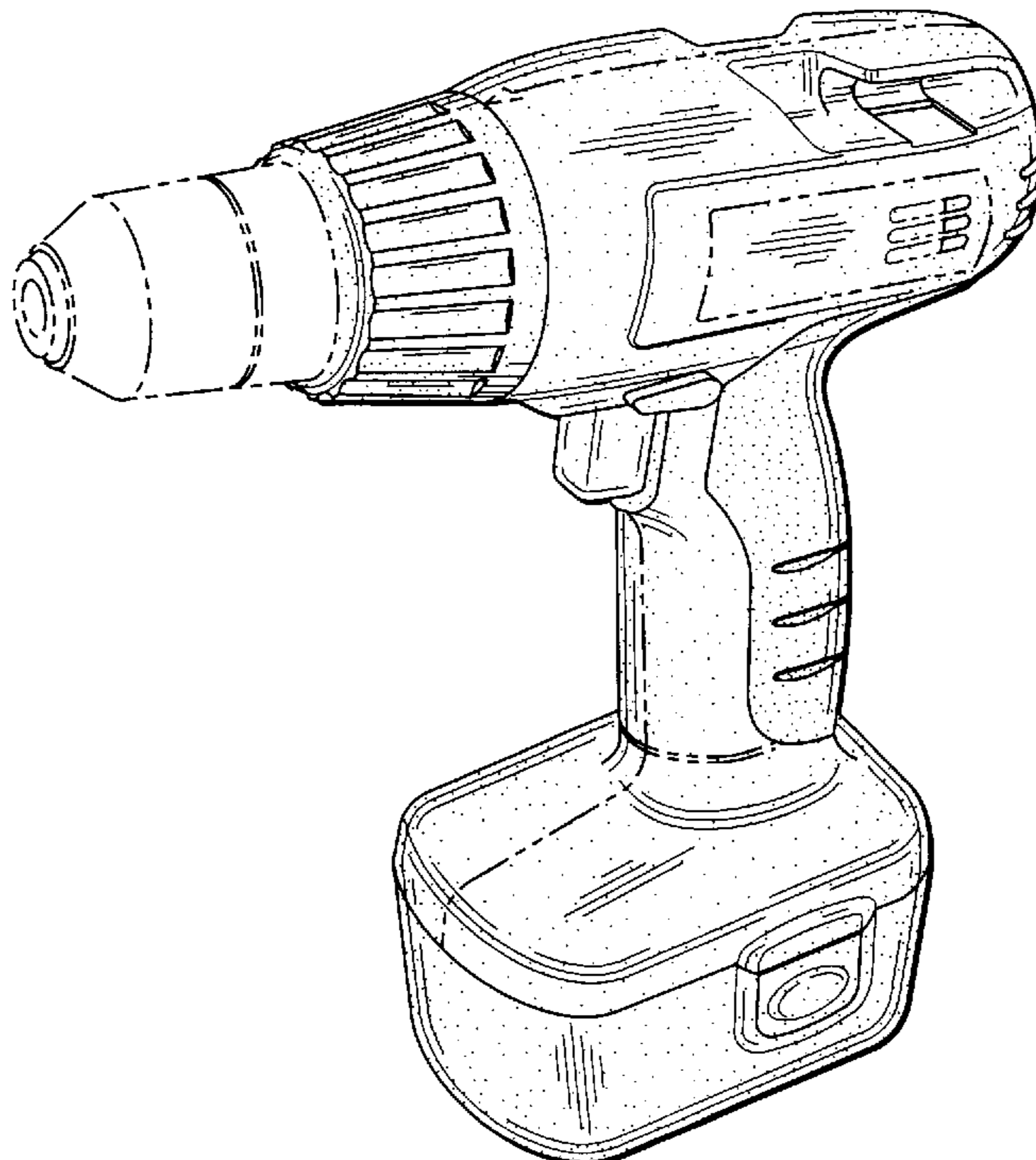

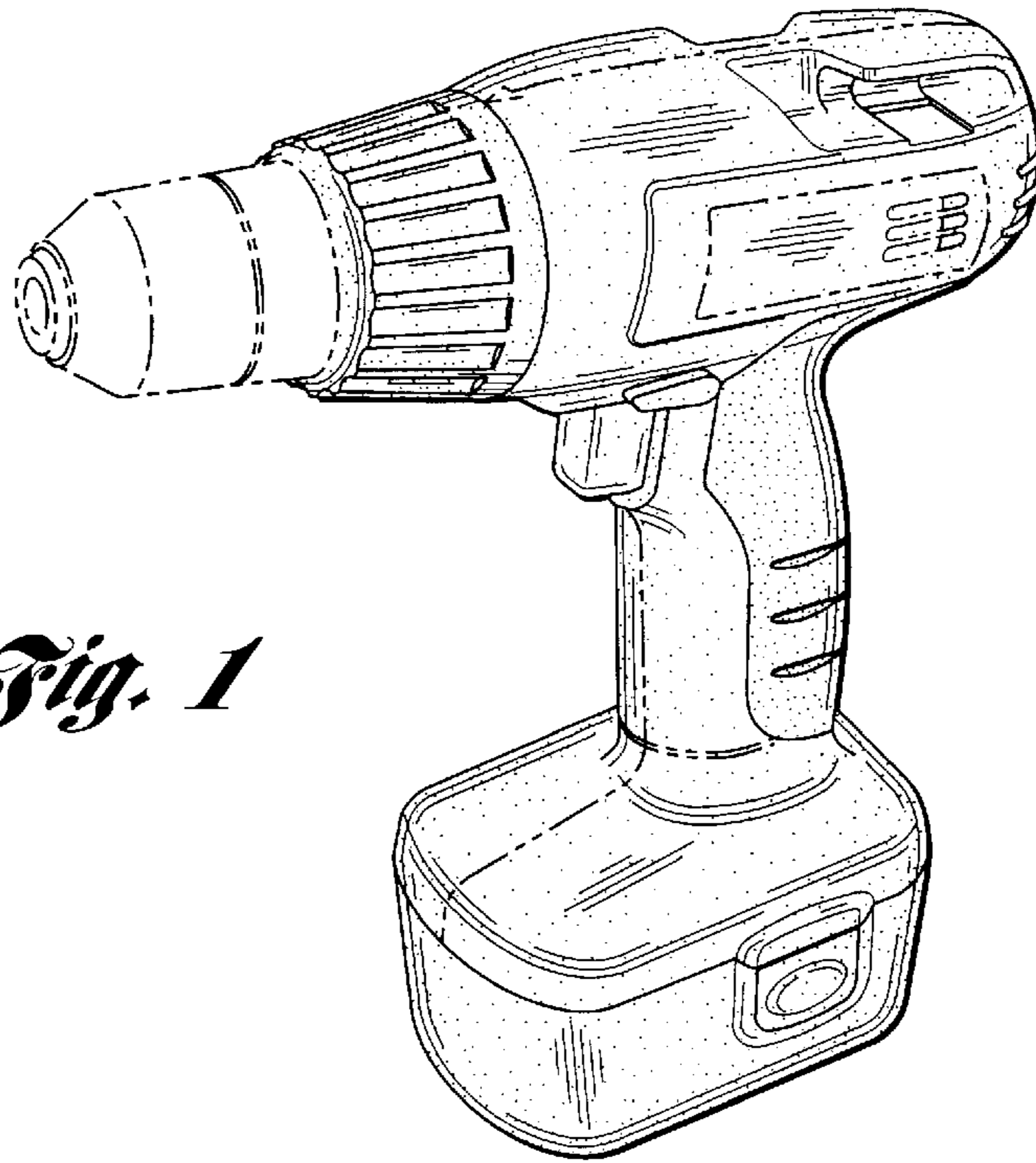

Fig. 1

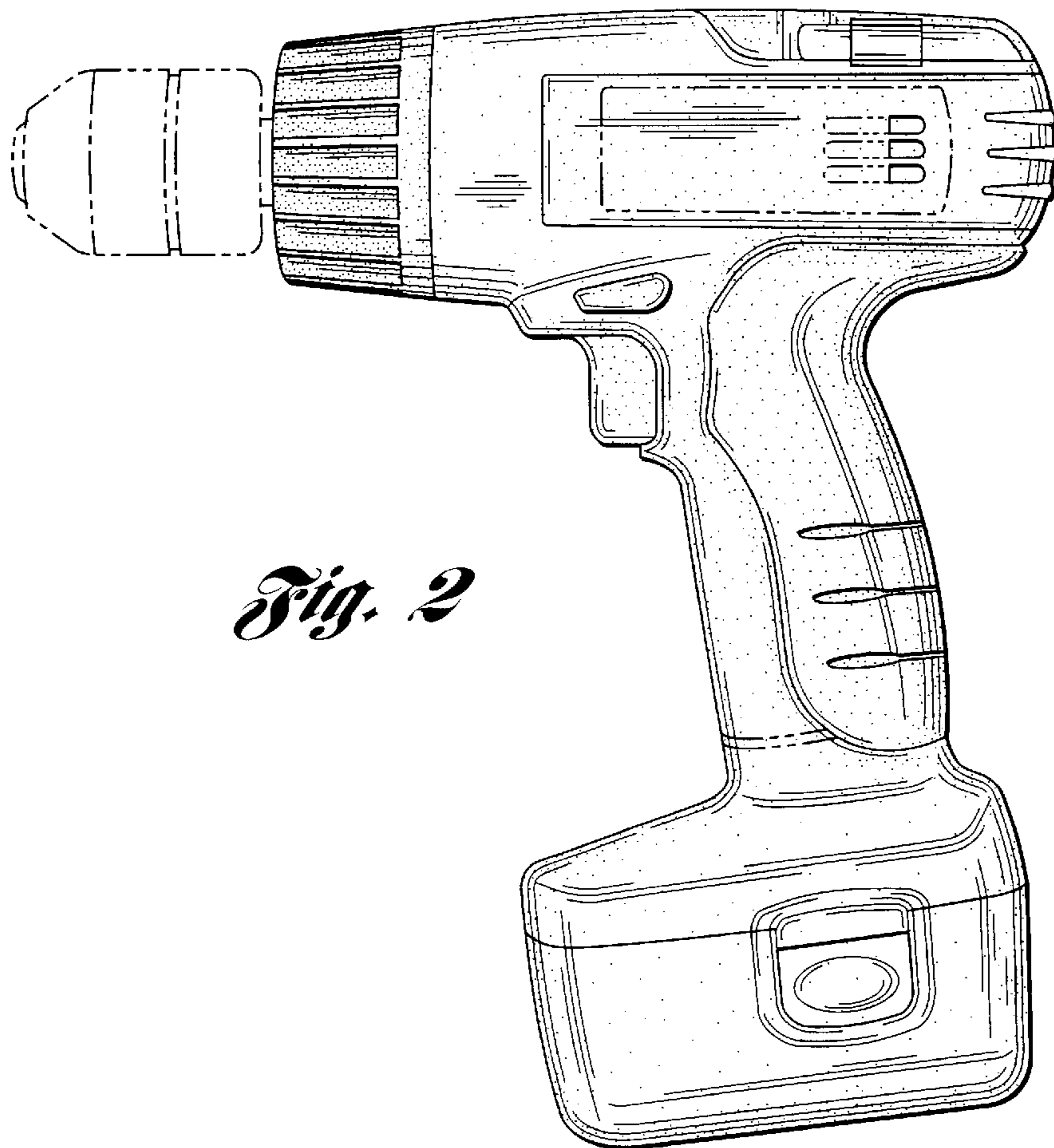

Fig. 2

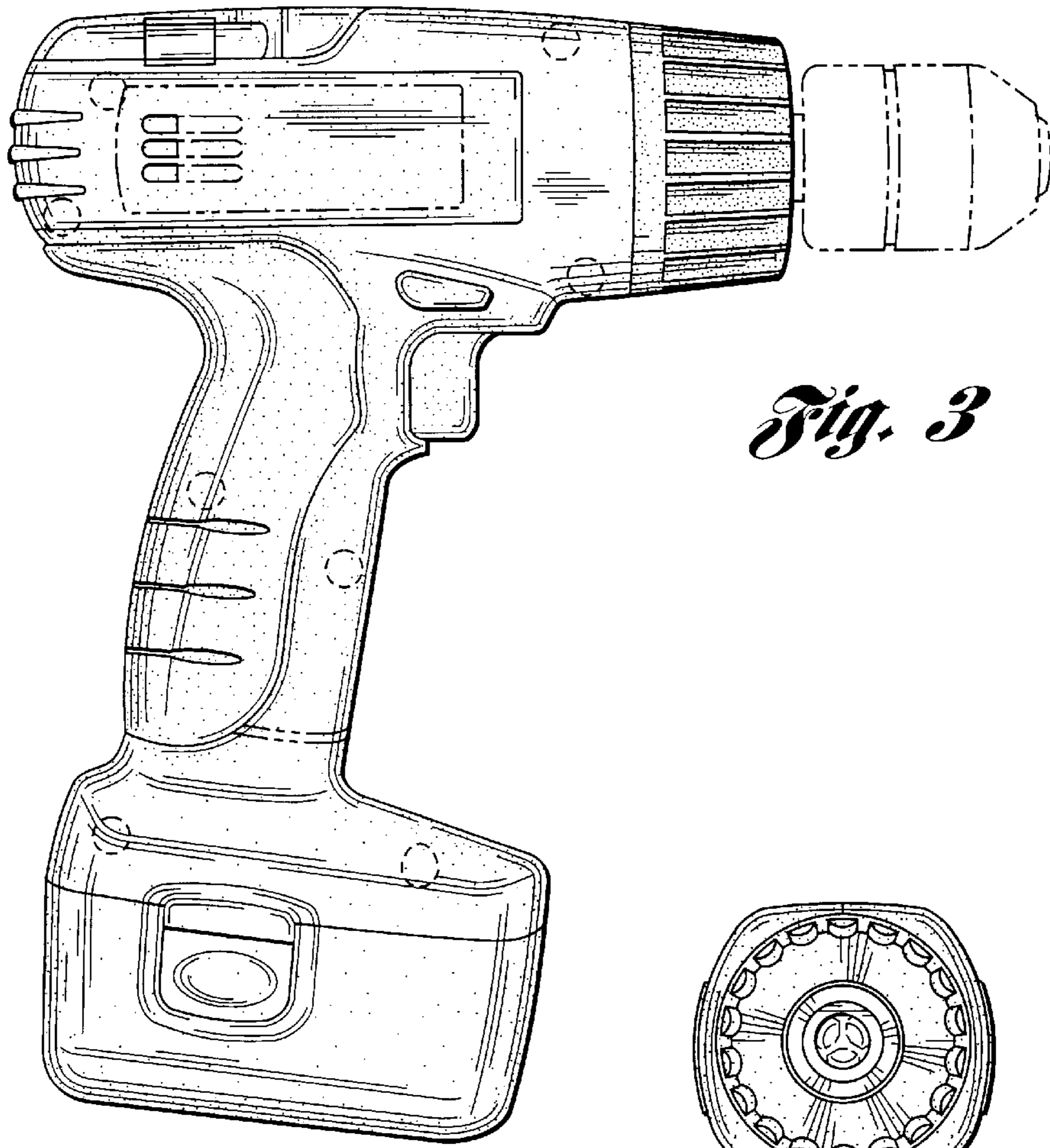

Fig. 3

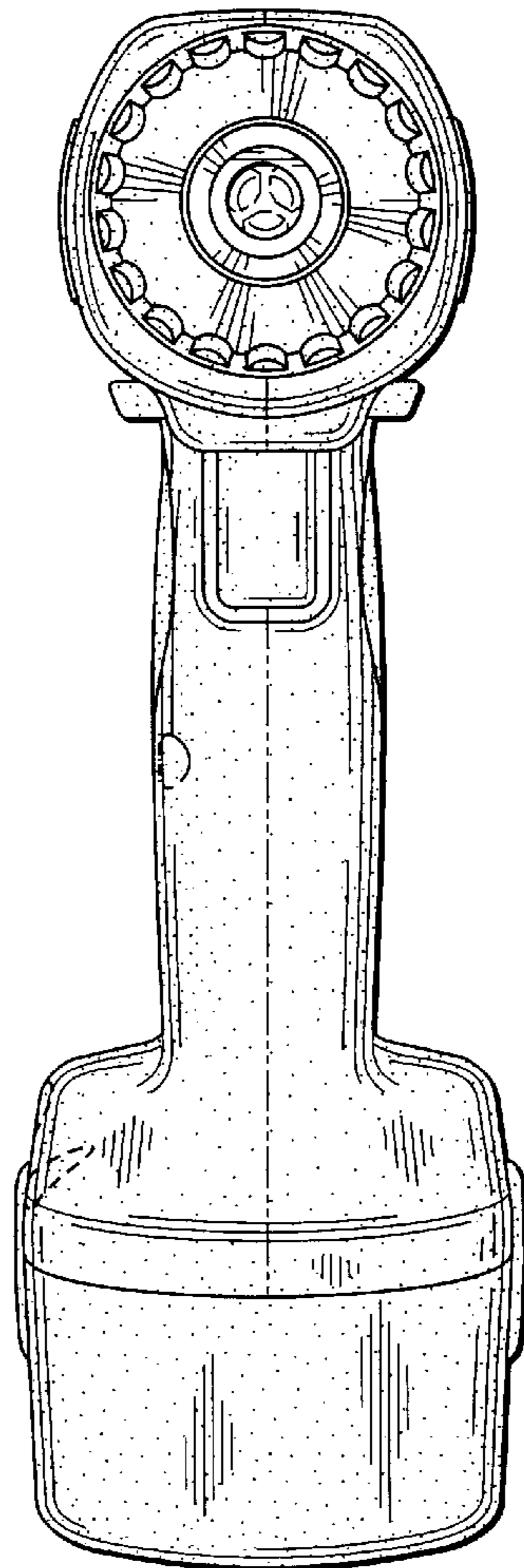

Fig. 4

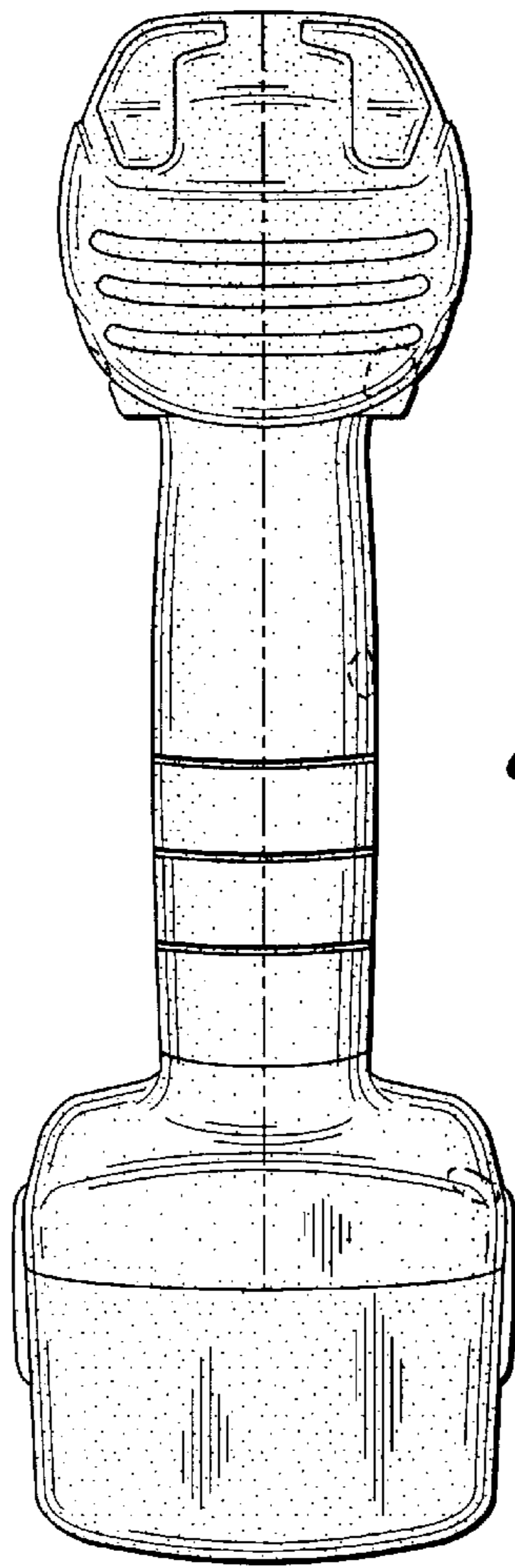

Fig. 5

Fig. 6

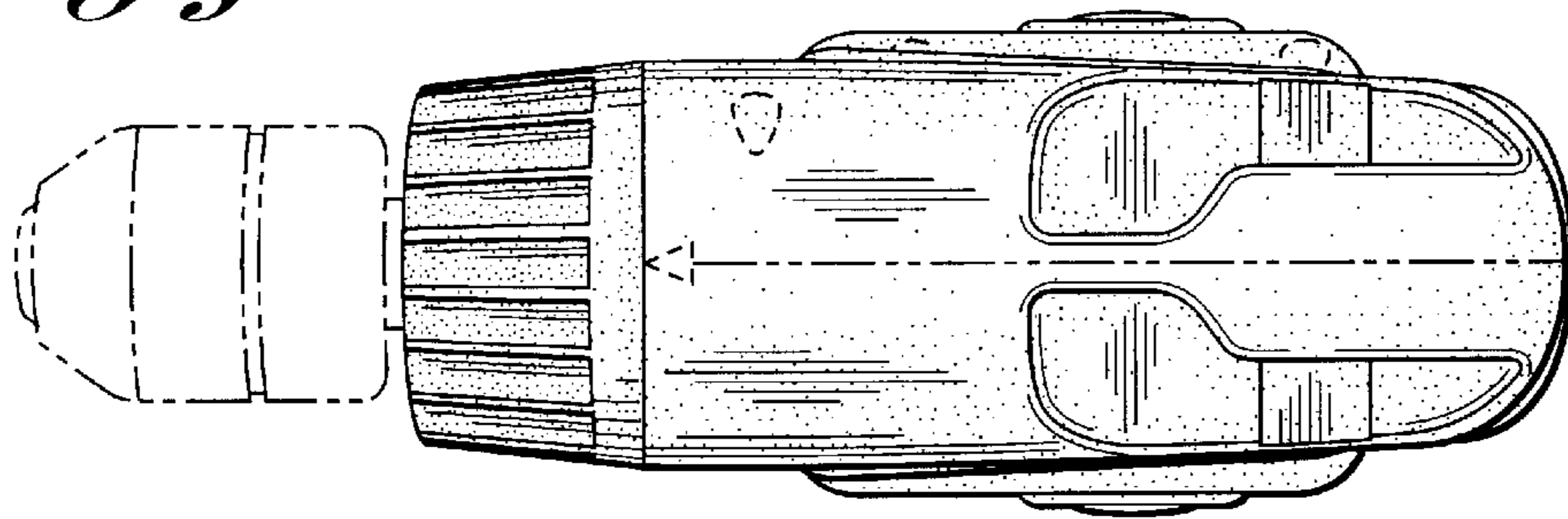

Fig. 7

