



US00D469535S

(12) **United States Design Patent**
Lidskog et al.

(10) **Patent No.:** **US D469,535 S**

(45) **Date of Patent:** **** Jan. 28, 2003**

(54) **ABUTMENT FOR DENTAL IMPLANT**

(75) **Inventors:** **Niklas Lidskog**, Concord, ME (US);
Nils Gustaf Bergström, Vagnhärad (SE)

(73) **Assignee:** **Astra Tech AB**, Molndal (SE)

(**) **Term:** **14 Years**

(21) **Appl. No.:** **29/150,033**

(22) **Filed:** **Nov. 1, 2001**

(51) **LOC (7) Cl.** **24-03**

(52) **U.S. Cl.** **D24/156**

(58) **Field of Search** D24/156; 433/172-174

(56) **References Cited**

U.S. PATENT DOCUMENTS

4,177,562 A	12/1979	Miller et al.	
4,253,833 A	3/1981	Edelman	
4,575,340 A	3/1986	Lustig	
4,738,623 A	4/1988	Driskell	
4,955,811 A	9/1990	Lazzara et al.	
4,995,810 A	2/1991	Söderberg	
5,125,841 A	6/1992	Carlsson et al.	
5,297,963 A	3/1994	Dafatry	
5,334,024 A	8/1994	Niznick	
5,376,004 A	12/1994	Mena	
5,516,288 A *	5/1996	Sichler et al.	433/173
D374,080 S *	9/1996	Broberg	D24/156
5,662,476 A	9/1997	Ingber et al.	
5,685,715 A	11/1997	Beaty et al.	
5,688,123 A	11/1997	Meiers et al.	
5,762,500 A	6/1998	Lazarof	
5,779,480 A	7/1998	Groll et al.	
5,816,809 A	10/1998	Sapkos	
5,829,981 A	11/1998	Ziegler	
5,899,695 A	5/1999	Lazzara et al.	
5,899,697 A	5/1999	Lazzara et al.	
5,904,483 A	5/1999	Wade	
5,938,443 A	8/1999	Lazzara et al.	
5,964,591 A	10/1999	Beaty et al.	
6,068,478 A	5/2000	Grande et al.	
6,120,293 A	9/2000	Lazzara et al.	
6,142,782 A	11/2000	Lazarof	

6,149,433 A	11/2000	Ziegler et al.	
6,155,828 A	12/2000	Lazzara et al.	
6,159,010 A	12/2000	Rogers et al.	
6,315,563 B1 *	11/2001	Sager	433/173

FOREIGN PATENT DOCUMENTS

DE	31 10693 A1	9/1982
EP	0 190 670 A2	8/1986
EP	0 814 724 B1	1/1998
EP	0 879 025 B1	11/1998
WO	WO 98/32393	7/1998
WO	WO 98/52490	11/1998
WO	WO 99/04723	2/1999
WO	WO 99/29255	6/1999

OTHER PUBLICATIONS

Brochure, "TG OSSEOTITE/ITI Impression Procedure Comparison", 3i Implant Innovations, Inc. (Rev Jan. 2001).
Brochure, "TG Post Restorative Guidelines Laboratory Procedure", 3i Implant Innovations, Inc.

* cited by examiner

Primary Examiner—Antoine Duval Davis

(74) *Attorney, Agent, or Firm*—Birch, Stewart, Kolasch & Birch, LLP

(57) **CLAIM**

The ornamental design for an abutment for dental implant, as shown and described.

DESCRIPTION

FIG. 1 is a front elevational view rotated 90° clockwise of an abutment for dental implant showing our new design; FIG. 2 is a bottom plan view thereof; FIG. 3 is a rear, top perspective view thereof; FIG. 4 is a rear, bottom perspective view thereof; FIG. 5 is a front elevational view thereof; FIG. 6 is a front elevational view rotated 90° clockwise of an abutment for dental implant showing our new design; FIG. 7 is a bottom plan view thereof; FIG. 8 is a rear, top perspective view thereof; FIG. 9 is a rear, bottom perspective view thereof; FIG. 10 is a front plan view thereof;

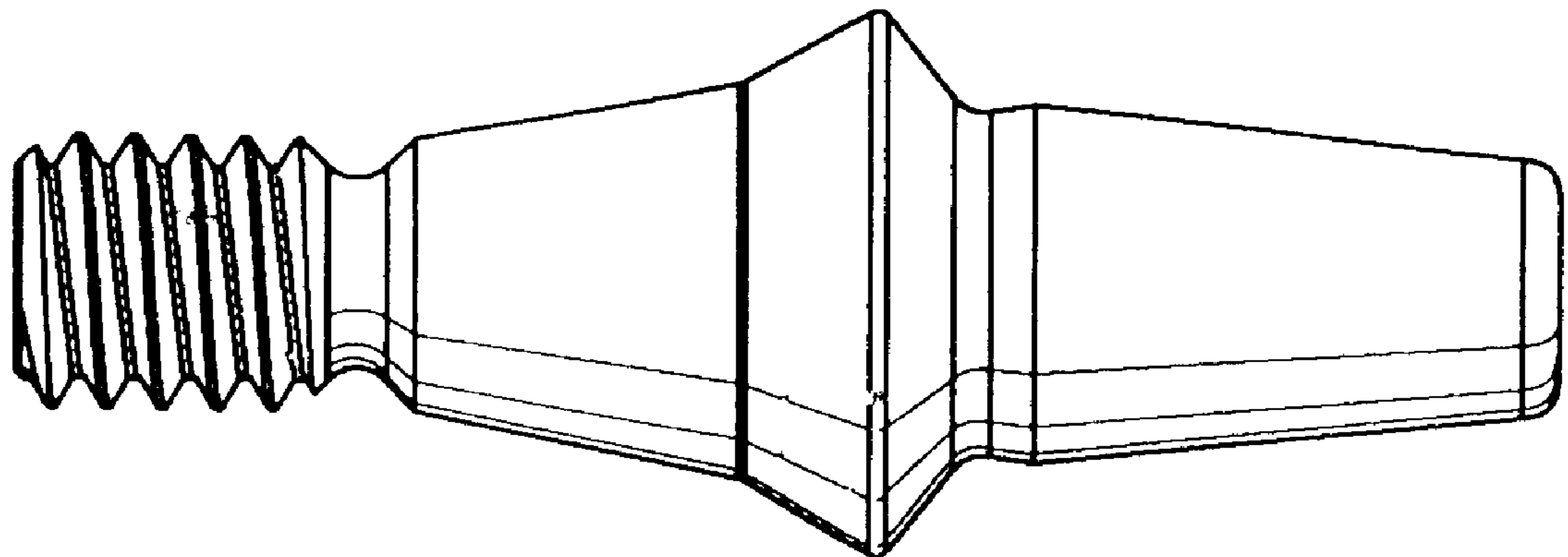

FIG. 11 is a front elevational view rotated 90° clockwise of an abutment for dental implant showing our new design;
FIG. 12 is a bottom plan view thereof;
FIG. 13 is a rear, top perspective view thereof;
FIG. 14 is a rear, bottom perspective view thereof;
FIG. 15 is a front plan view thereof;
FIG. 16 is a front elevational view rotated 90° clockwise of an abutment for dental implant showing our new design;
FIG. 17 is a bottom plan view thereof;
FIG. 18 is a rear, top perspective view thereof;
FIG. 19 is a rear, bottom perspective view thereof;
FIG. 20 is a front plan view thereof;
FIG. 21 is a front elevational view rotated 90° clockwise of an abutment for dental implant showing our new design;
FIG. 22 is a bottom plan view thereof;
FIG. 23 is a rear, top perspective view thereof;
FIG. 24 is a rear, bottom perspective view thereof;
FIG. 25 is a front plan view thereof;
FIG. 26 is a front elevational view rotated 90° clockwise of an abutment for dental implant showing our new design;
FIG. 27 is a bottom plan view thereof;
FIG. 28 is a rear, top perspective view thereof;
FIG. 29 is a rear, bottom perspective view thereof;
FIG. 30 is a front plan view thereof;
FIG. 31 is a front elevational view rotated 90° clockwise of an abutment for dental implant showing our new design;

FIG. 32 is a bottom plan view thereof;
FIG. 33 is a rear, top perspective view thereof;
FIG. 34 is a rear, bottom perspective view thereof;
FIG. 35 is a front plan view thereof;
FIG. 36 is a front elevational view rotated 90° clockwise of an abutment for dental implant showing our new design;
FIG. 37 is a bottom plan view thereof;
FIG. 38 is a rear, top perspective view thereof;
FIG. 39 is a rear, bottom perspective view thereof;
FIG. 40 is a front plan view thereof;
FIG. 41 is a front elevational view rotated 90° clockwise of an abutment for dental umplant showing our new design;
FIG. 42 is a bottom plan view thereof;
FIG. 43 is a rear, top perspective view thereof;
FIG. 44 is a rear, bottom perspective view thereof;
FIG. 45 is a front plan view thereof;
FIG. 46 is a front elevational view rotated 90° clockwise of an abutment for dental implant showing our new design;
FIG. 47 is a bottom plan view thereof;
FIG. 48 is a rear, top perspective view thereof;
FIG. 49 is a rear, bottom perspective view thereof; and,
FIG. 50 is a front plan view thereof.

1 Claim, 10 Drawing Sheets

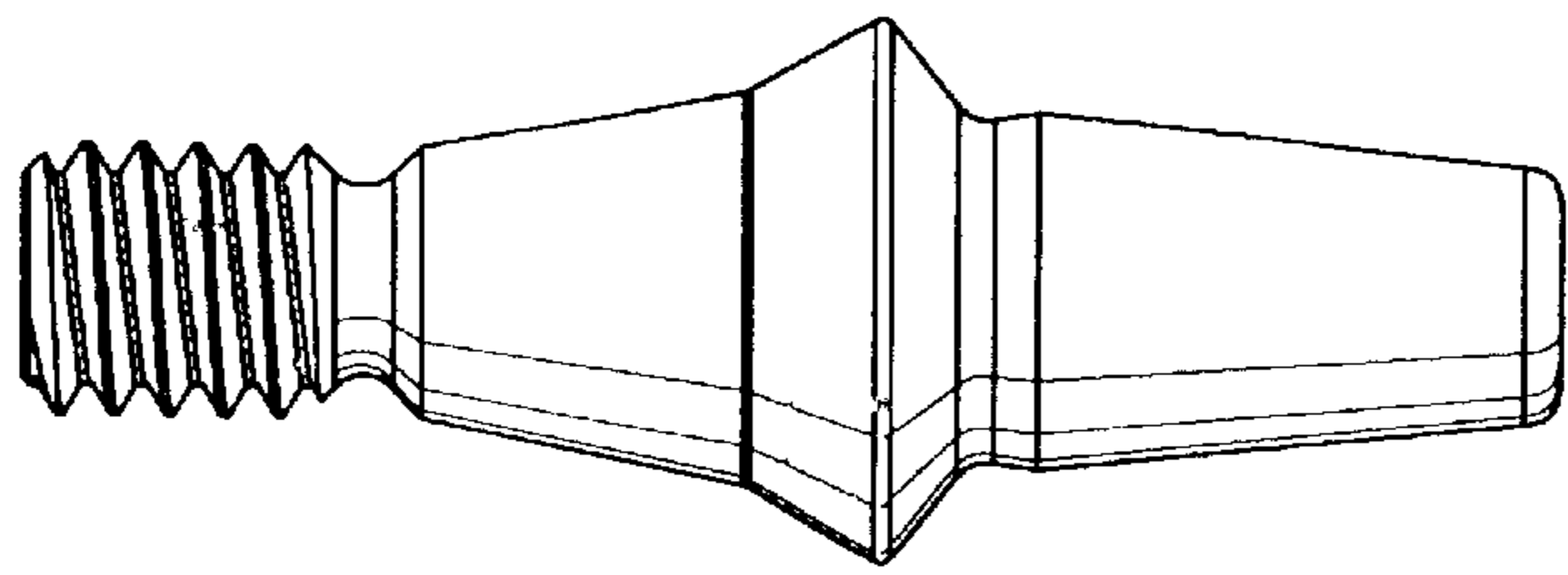

Figure 1

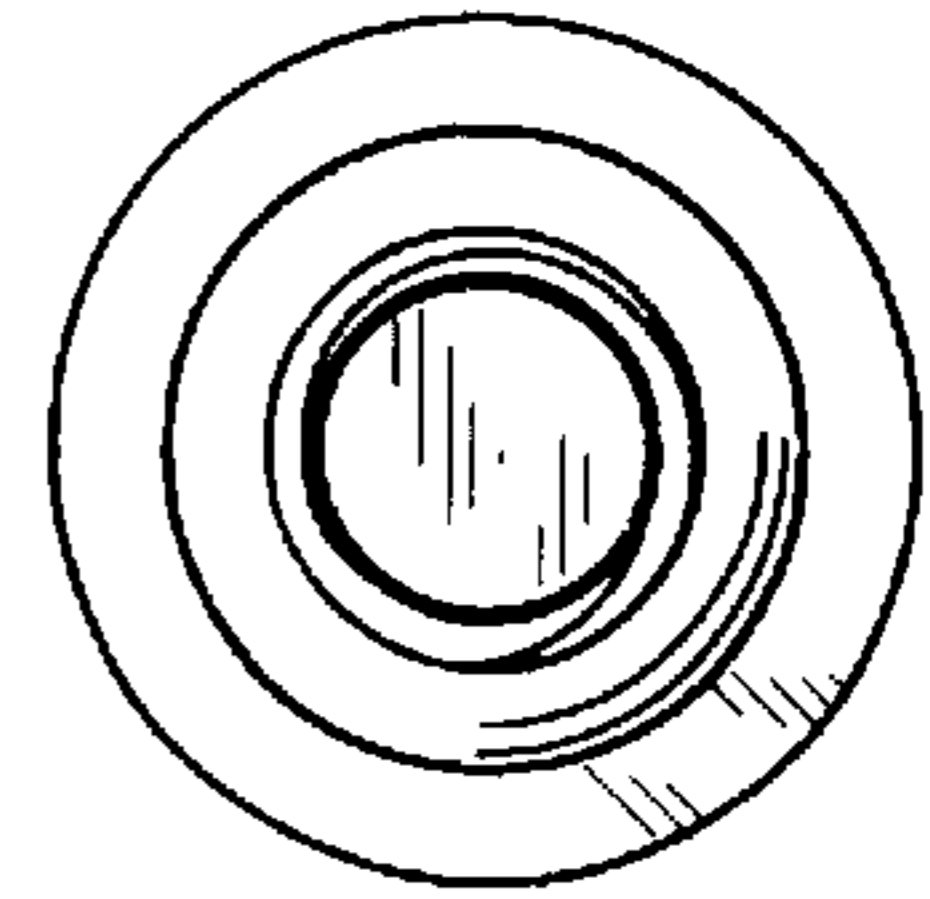

Figure 2

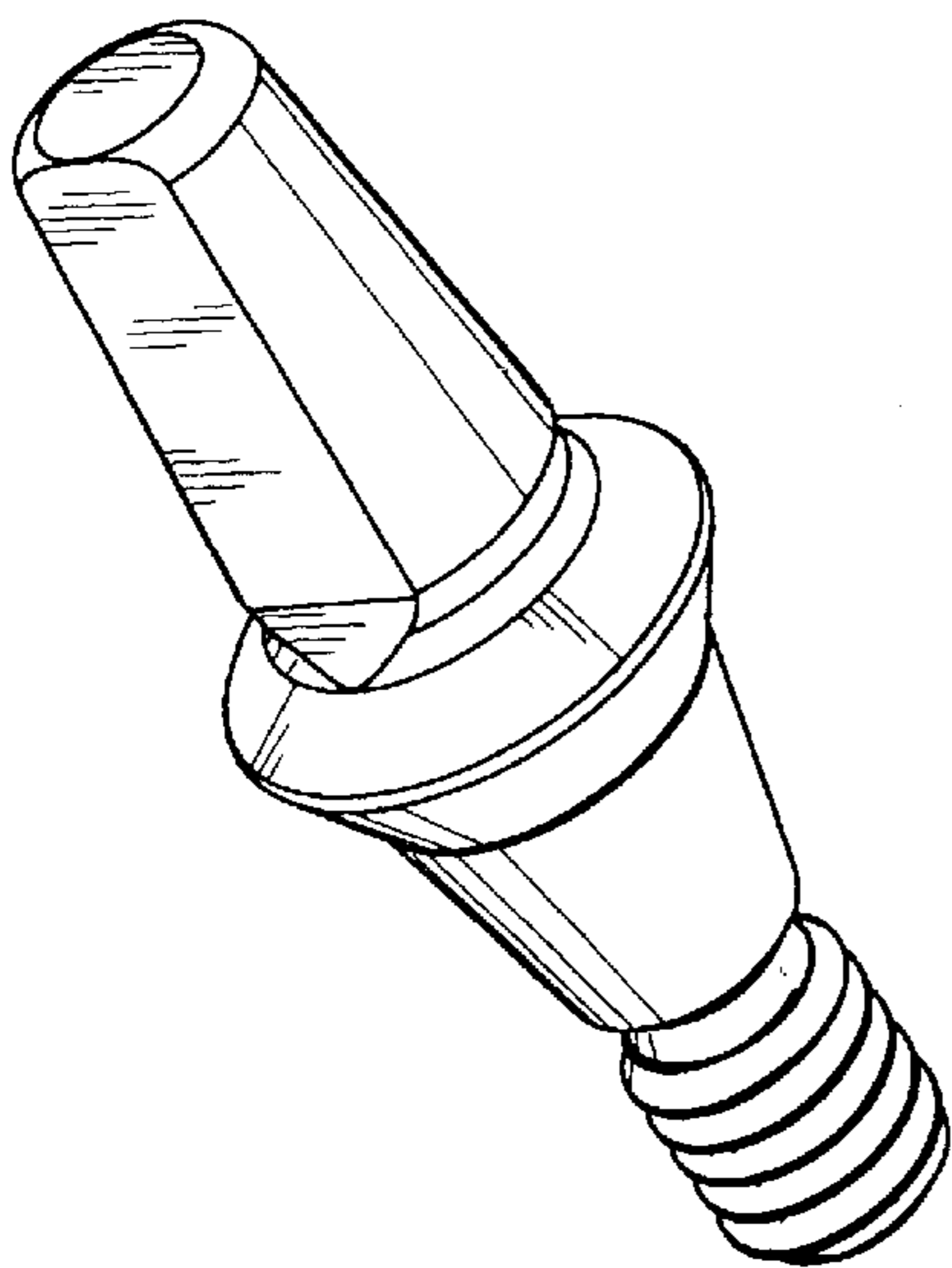

Figure 3

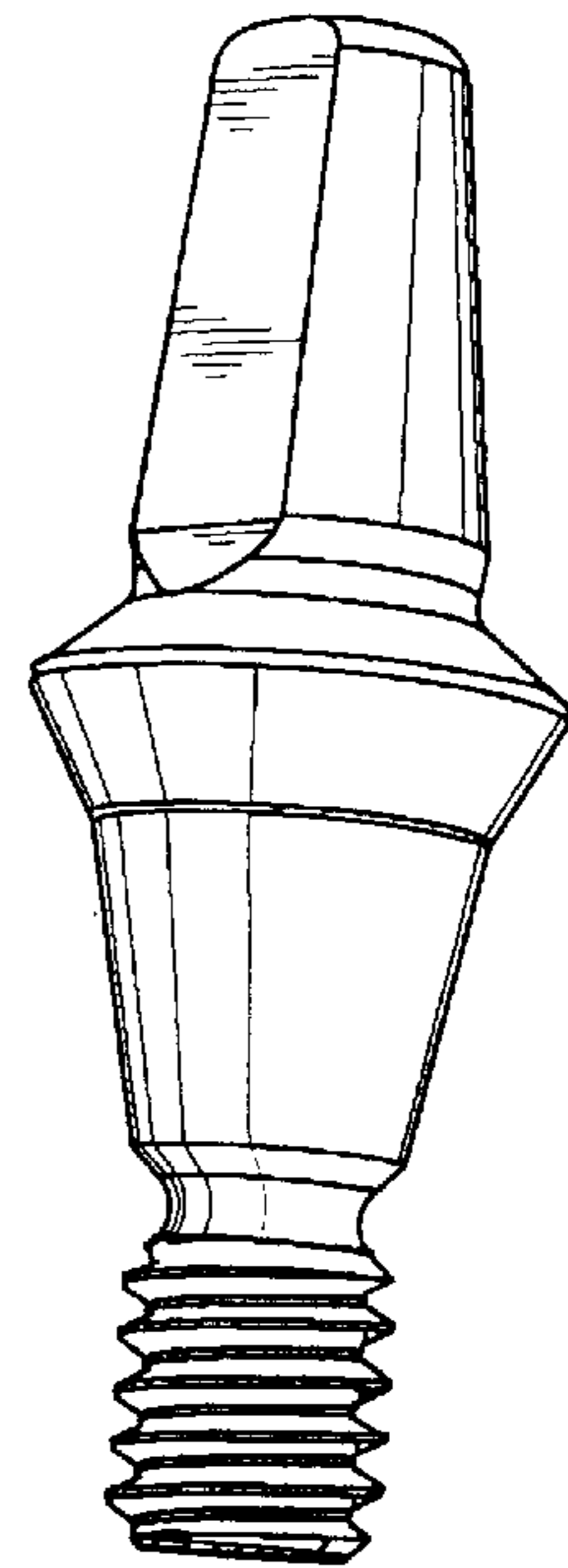

Figure 4

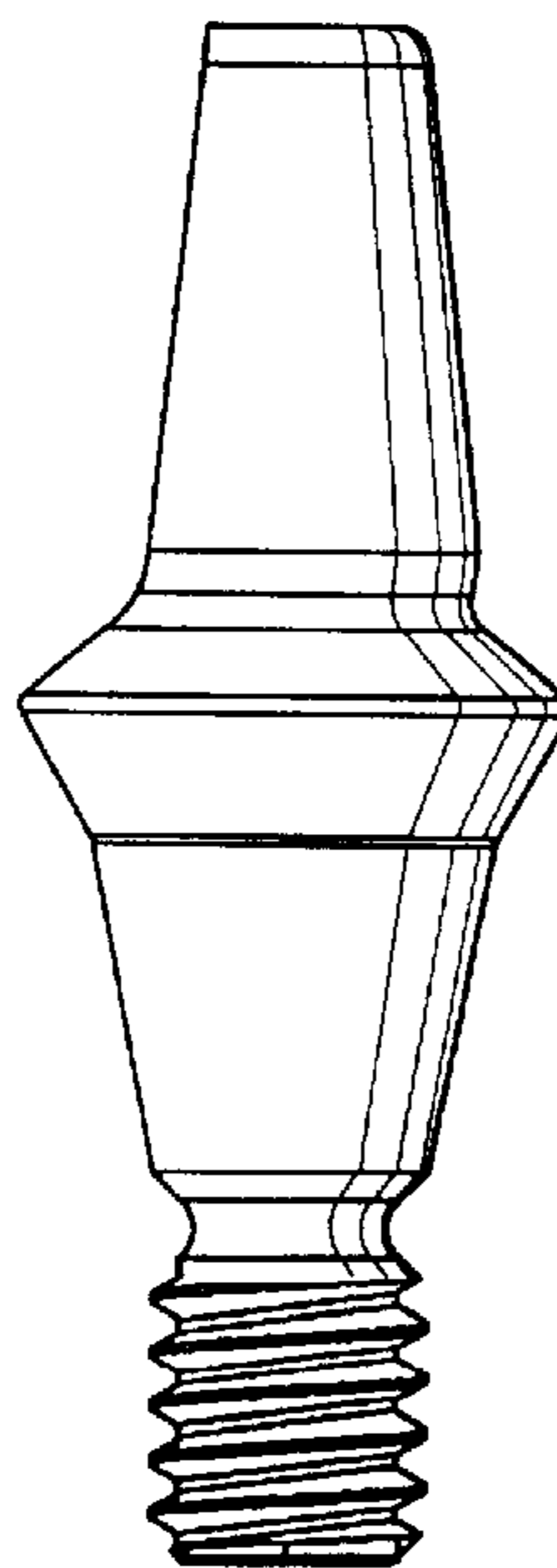

Figure 5

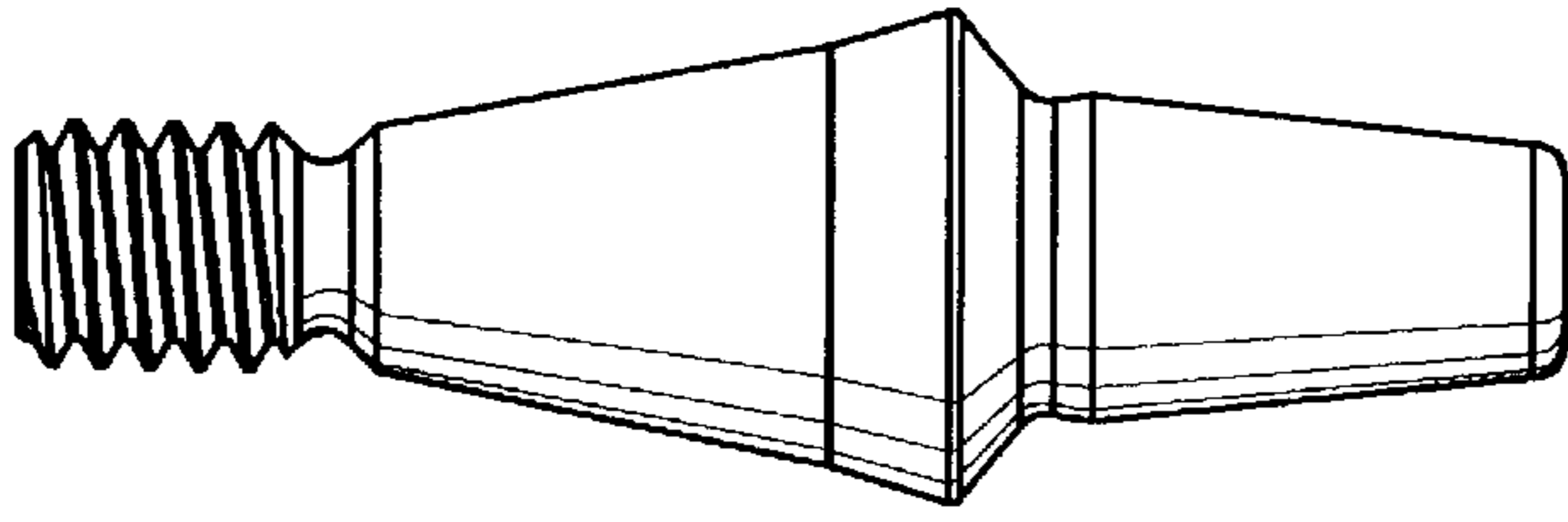

Figure 6

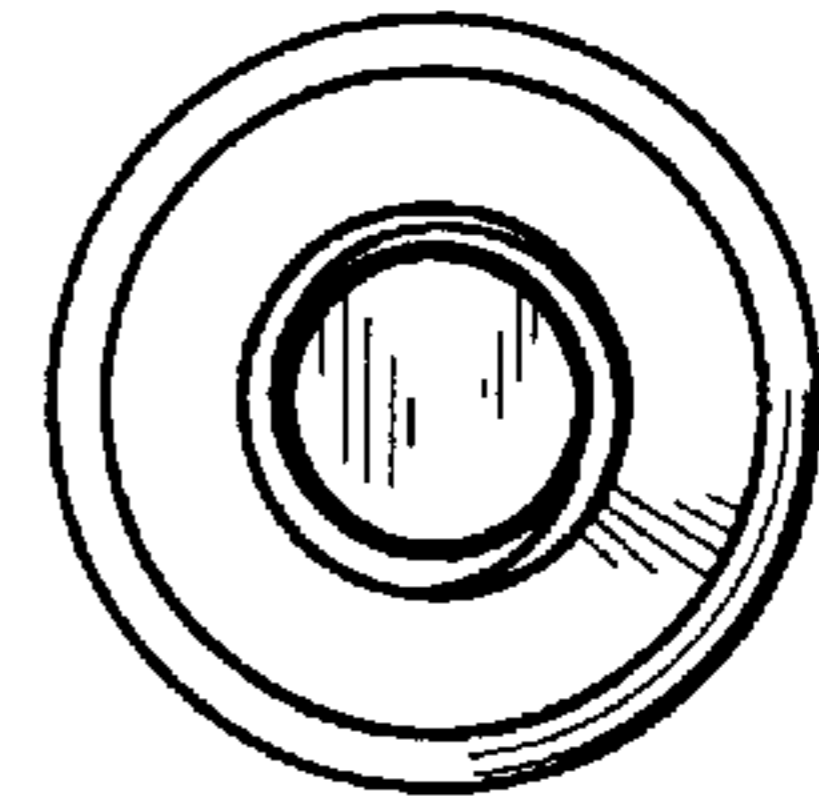

Figure 7

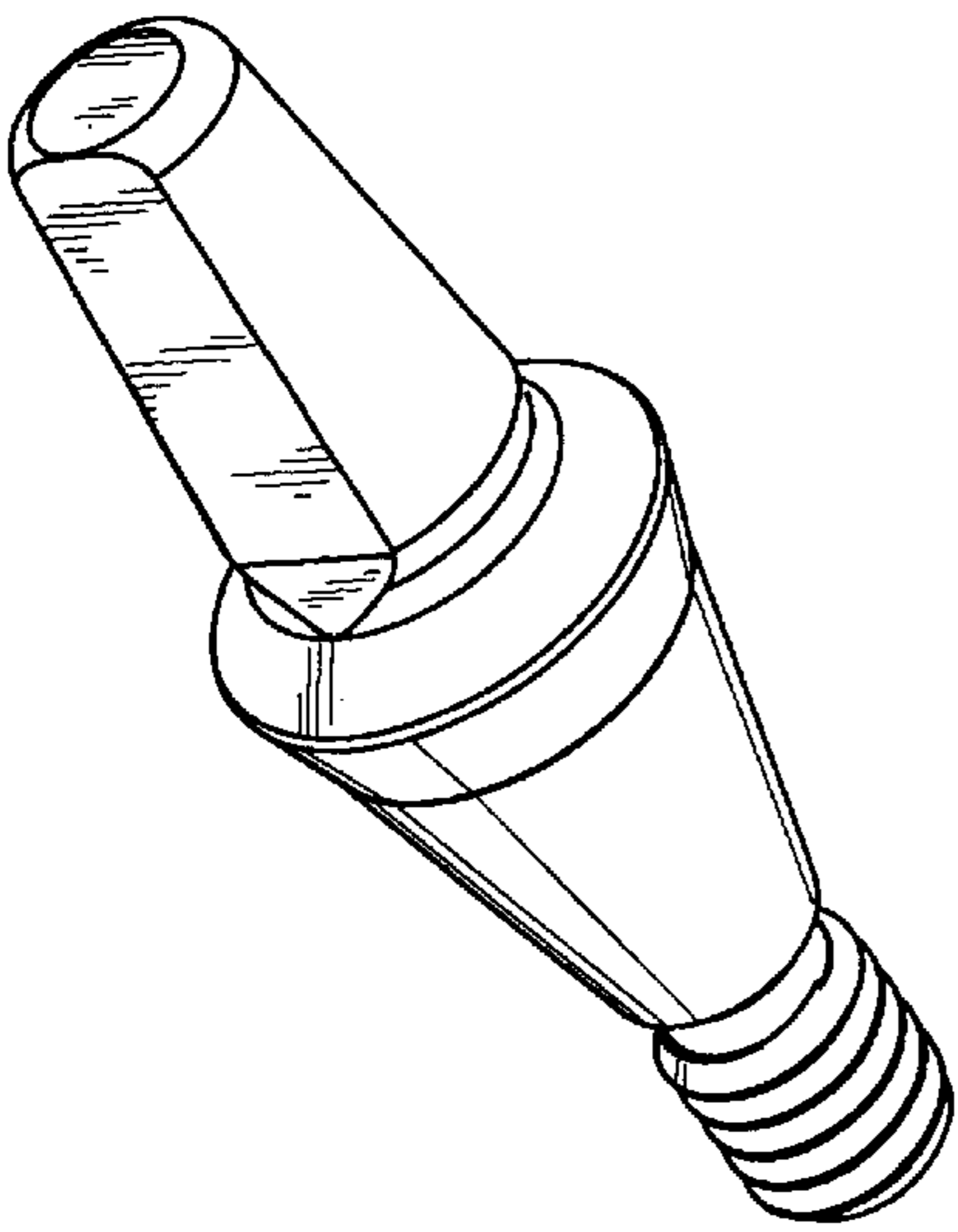

Figure 8

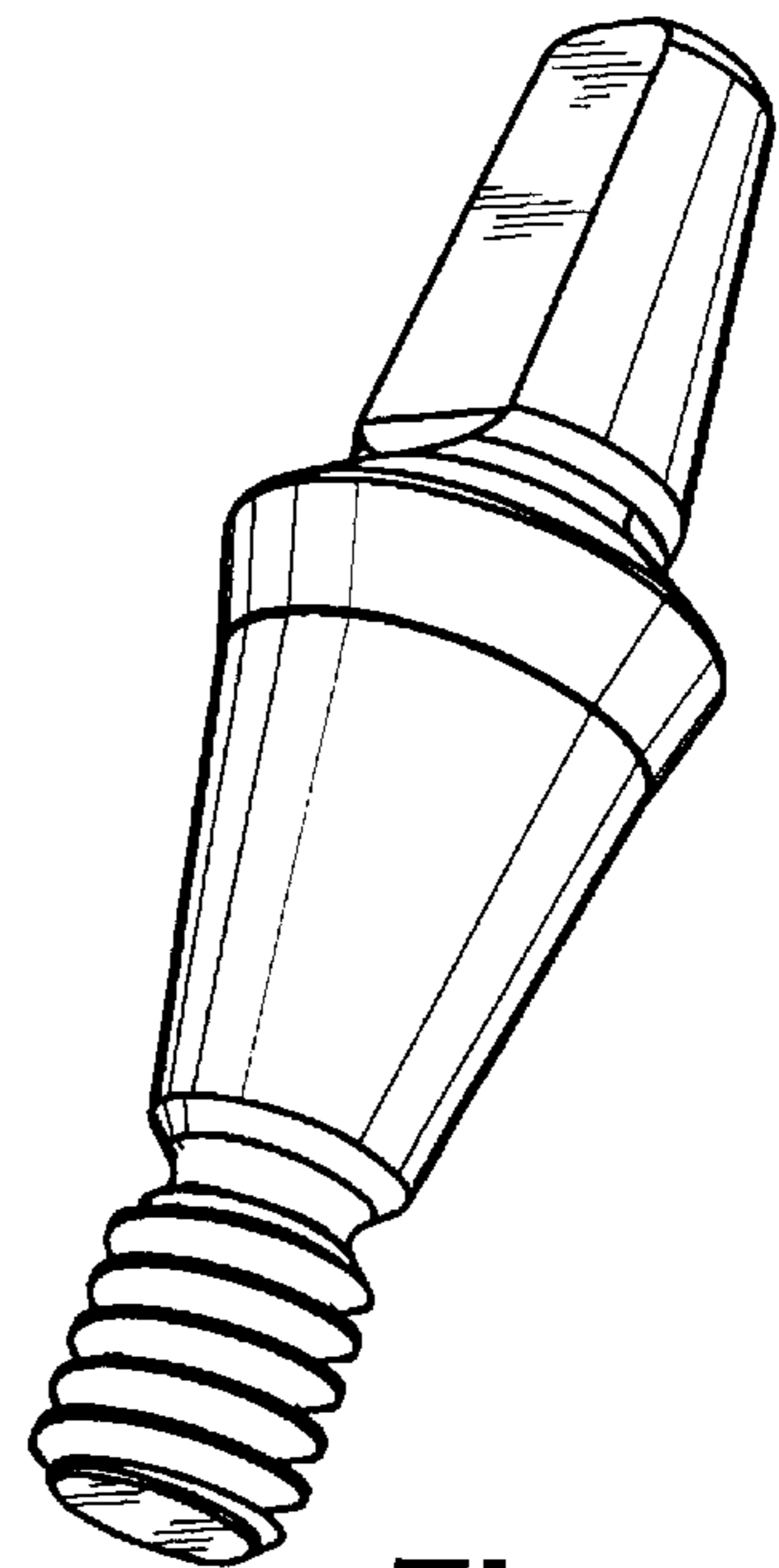

Figure 9

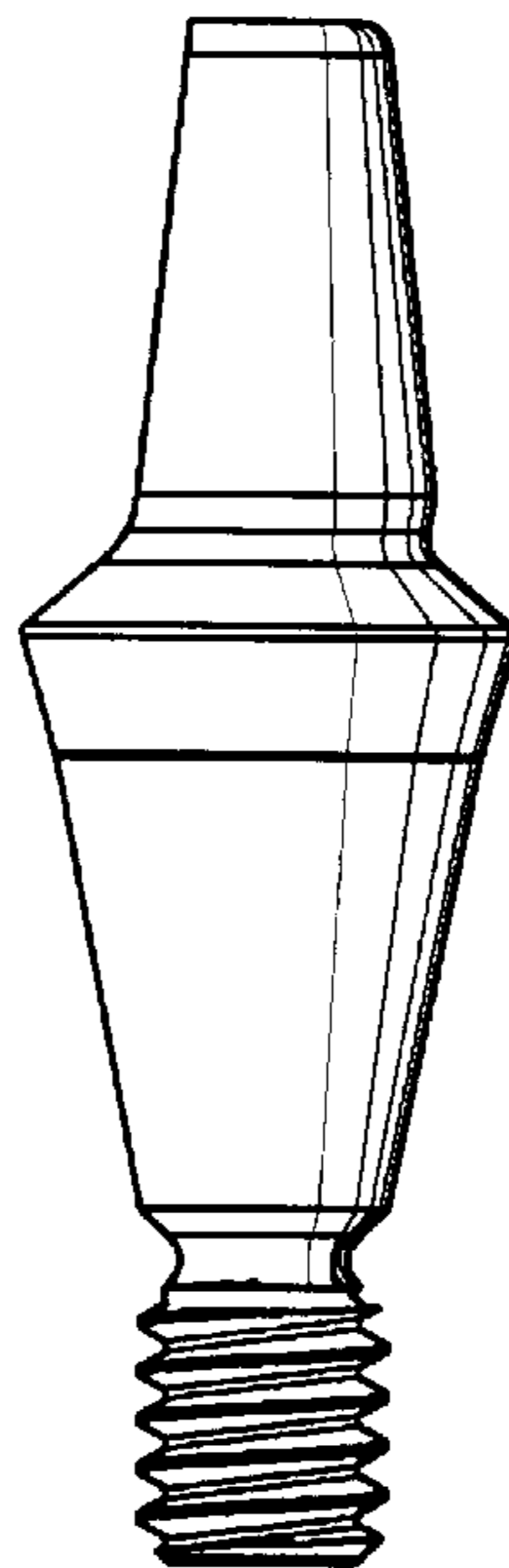

Figure 10

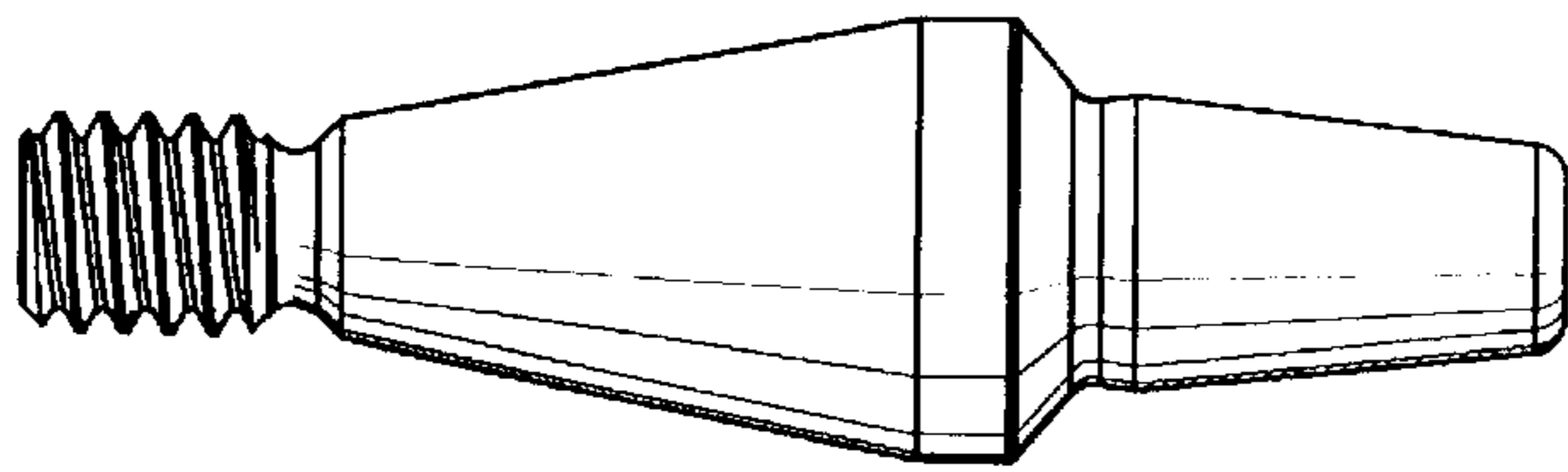

Figure 11

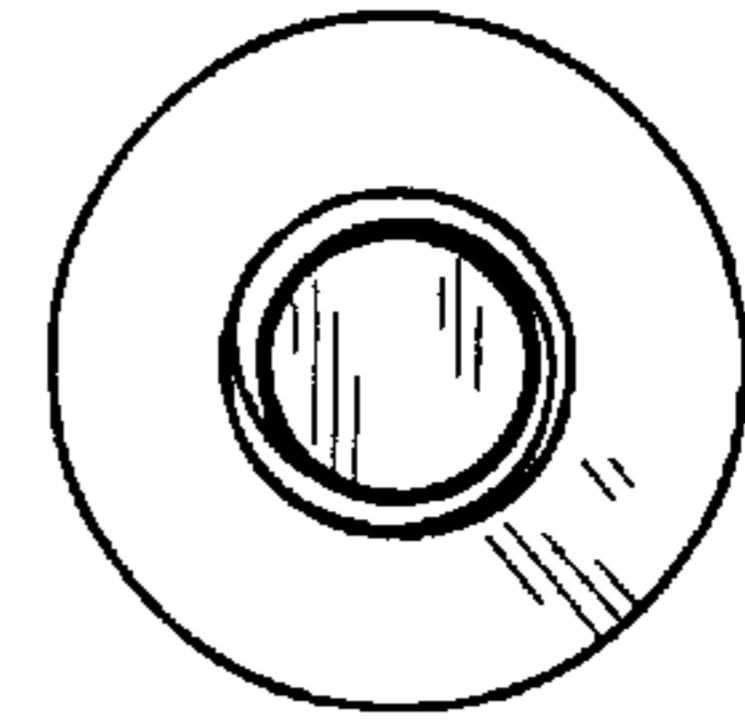

Figure 12

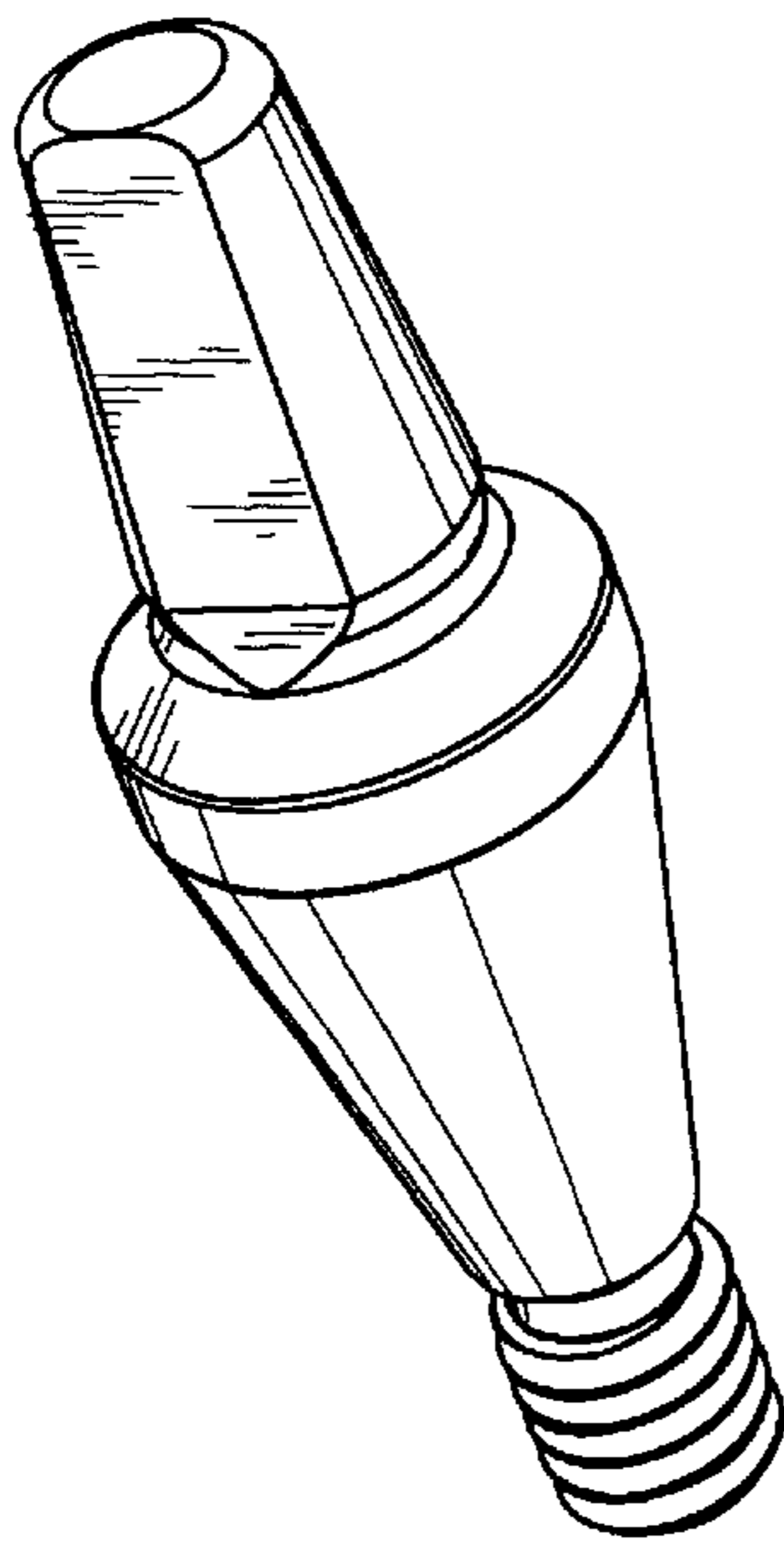

Figure 13

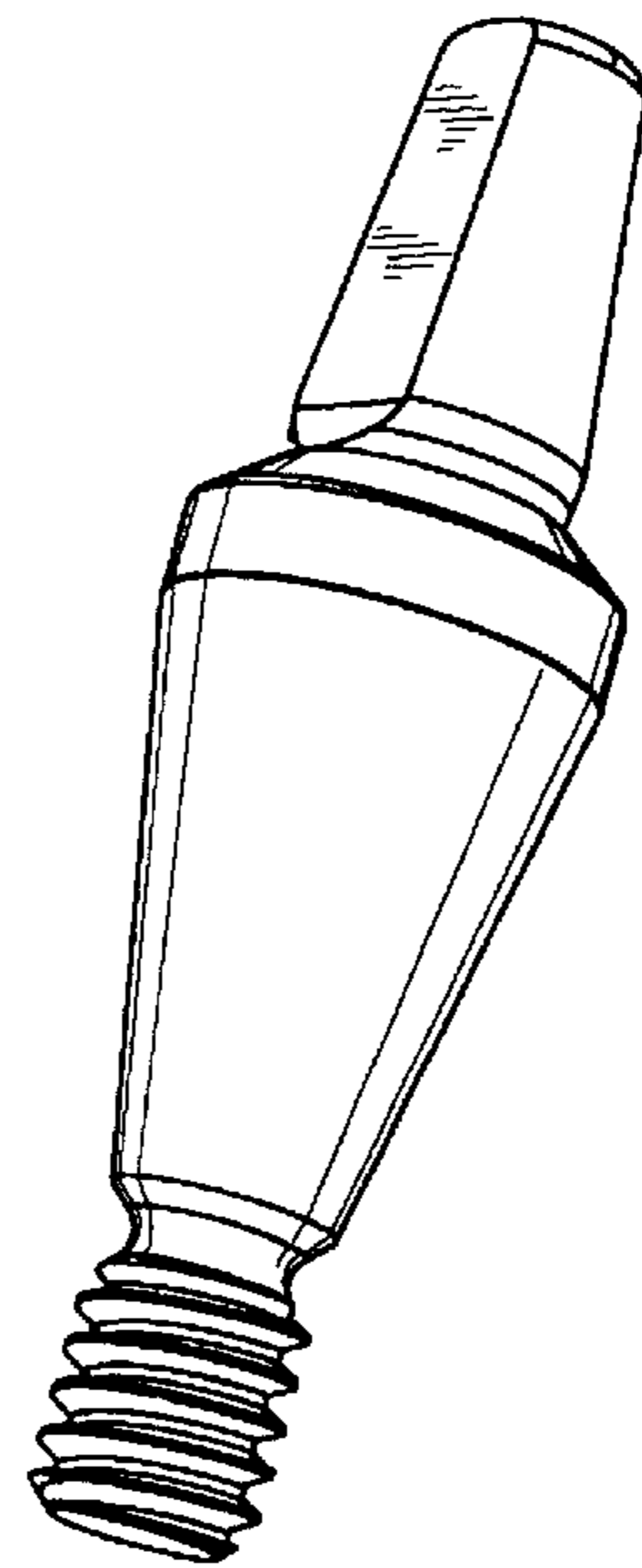

Figure 14

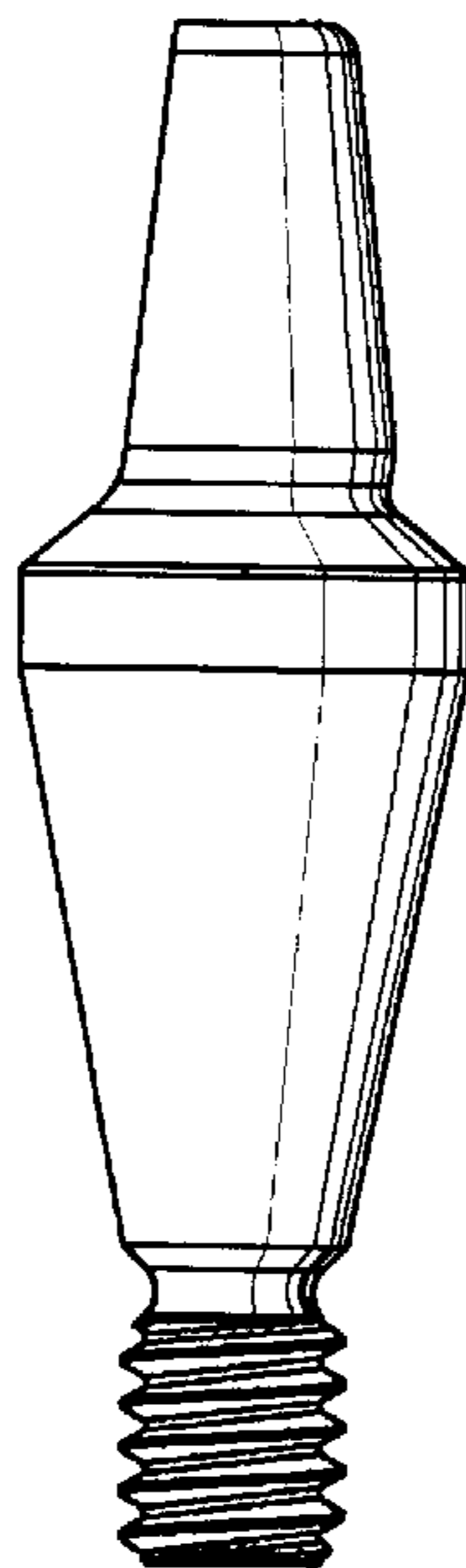

Figure 15

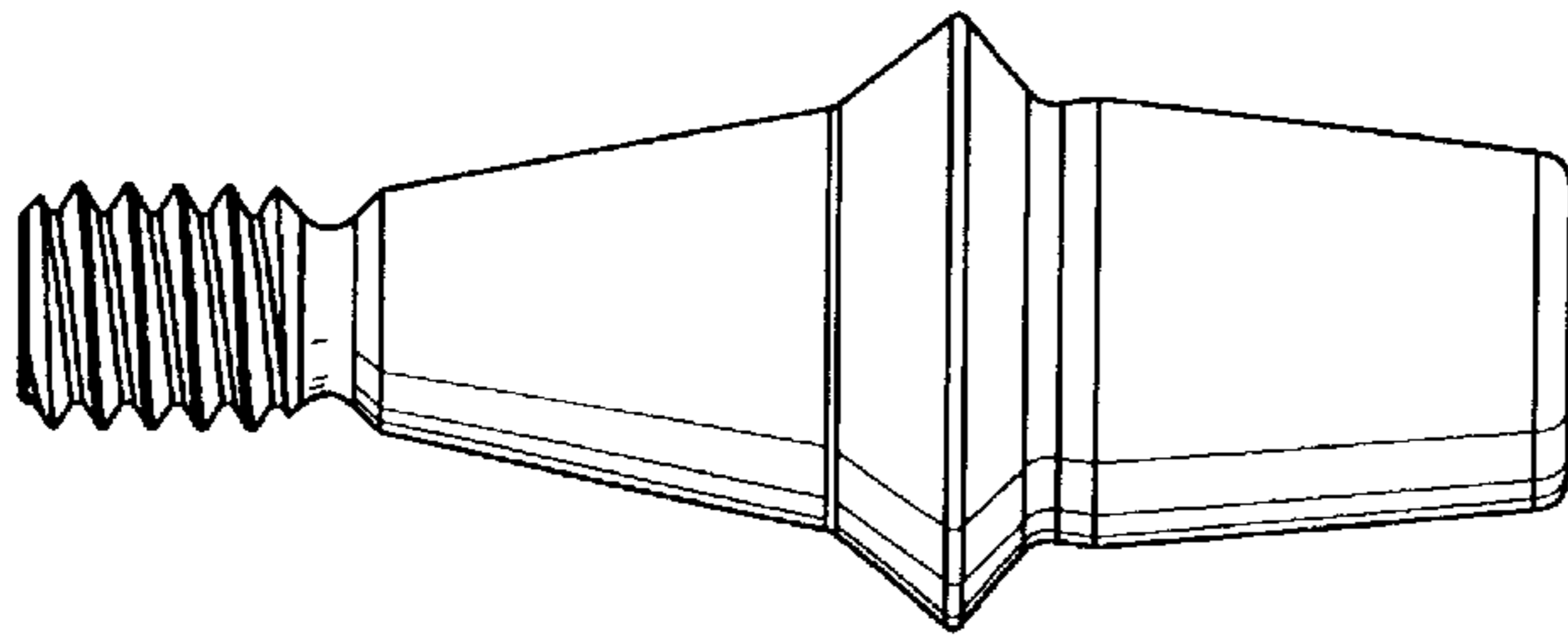

Figure 16

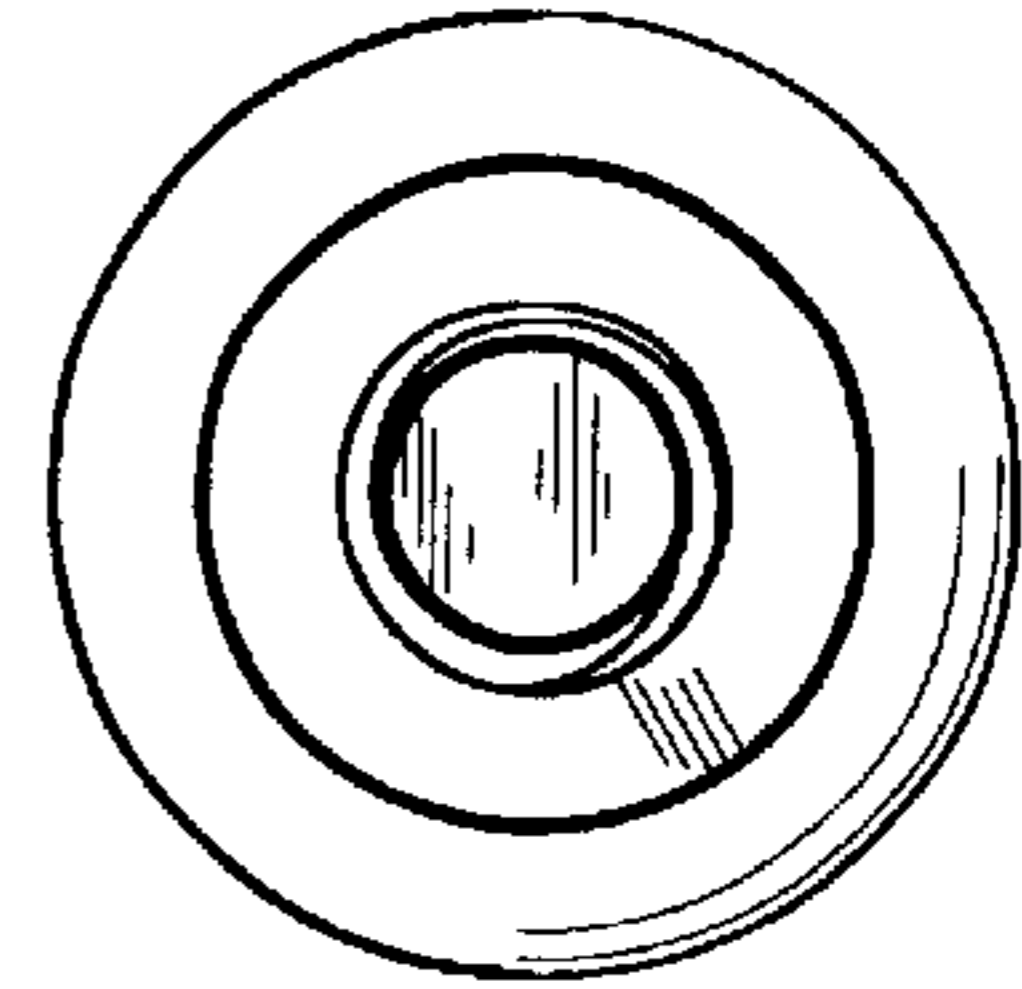

Figure 17

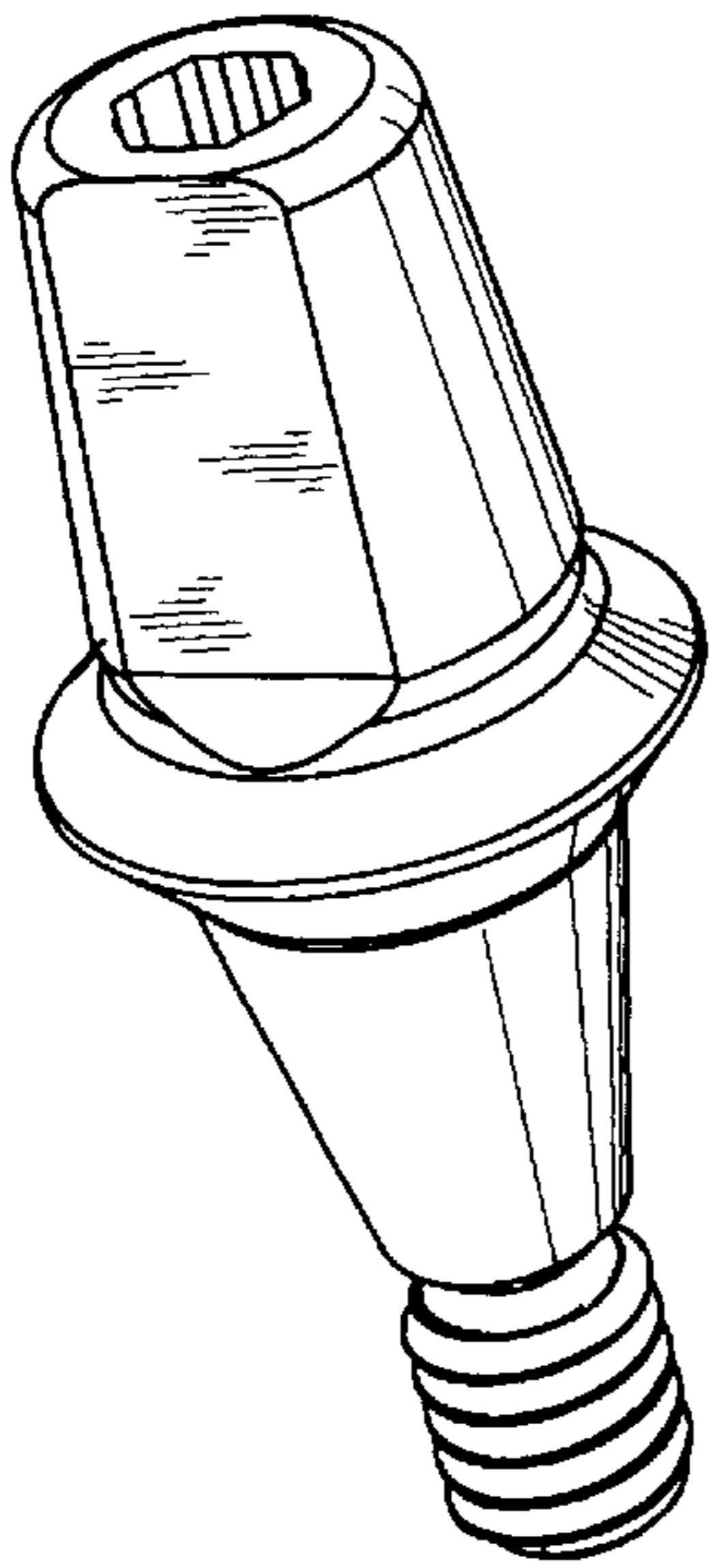

Figure 18

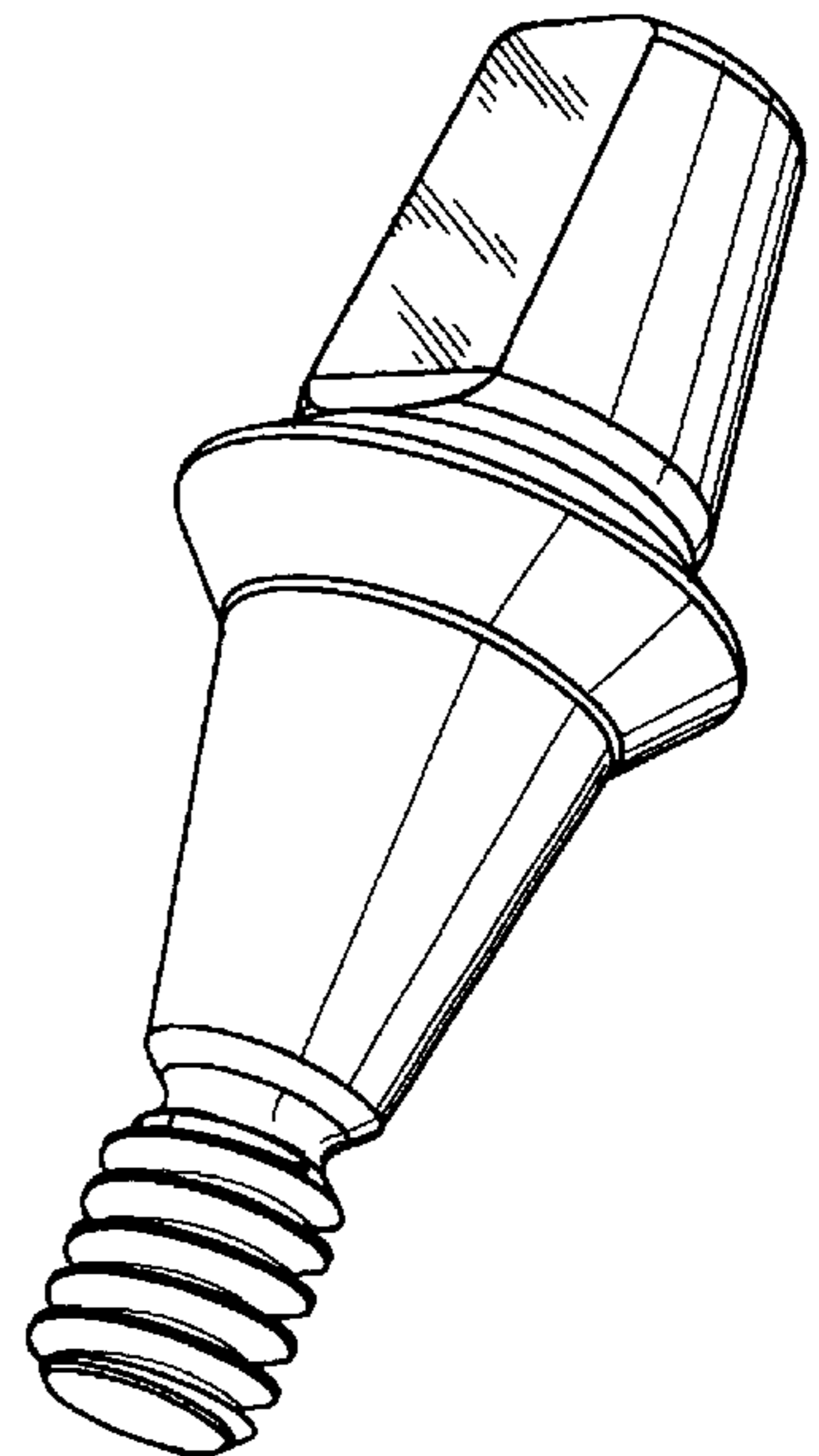

Figure 19

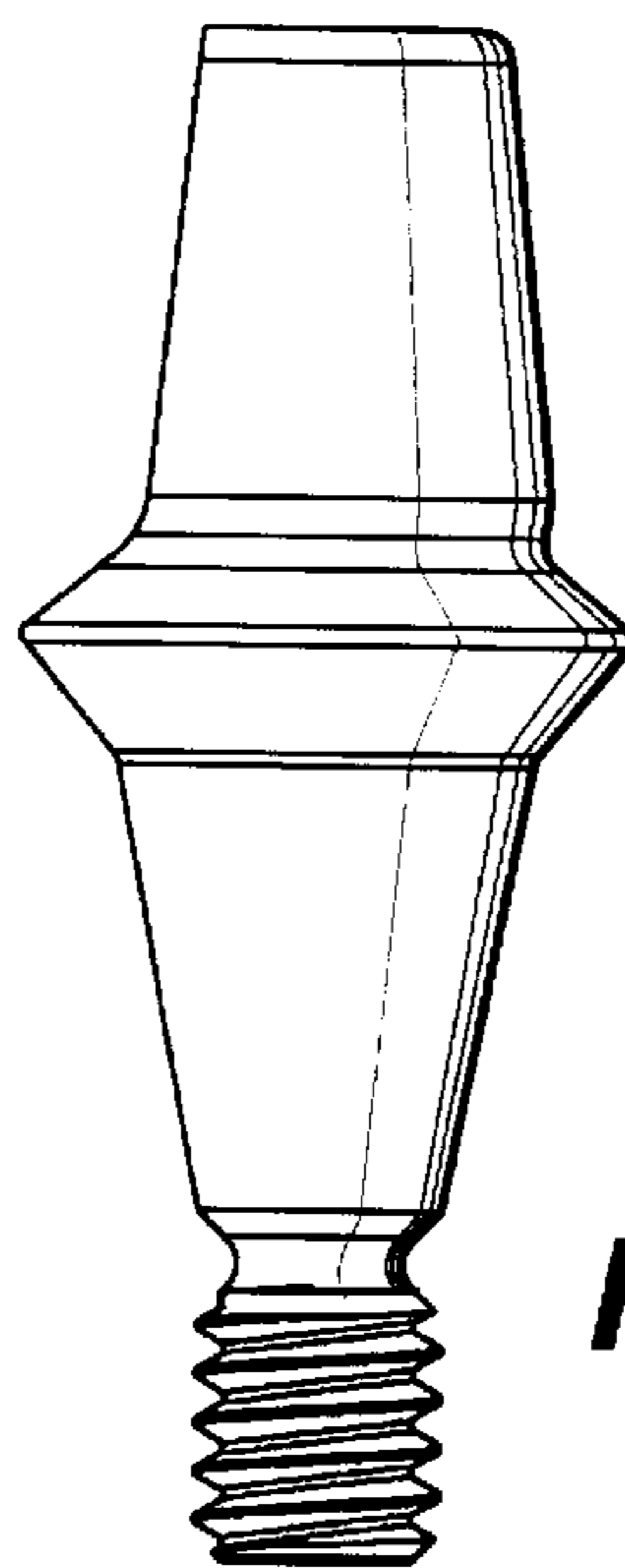

Figure 20

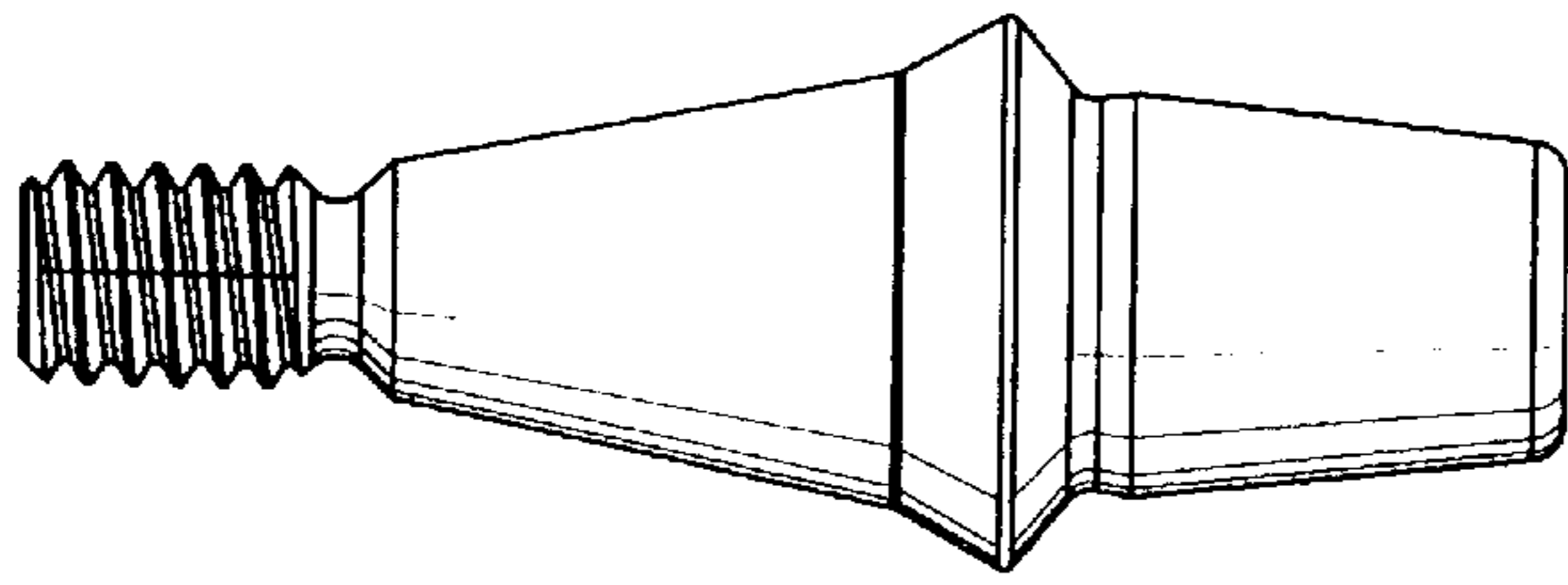

Figure 21

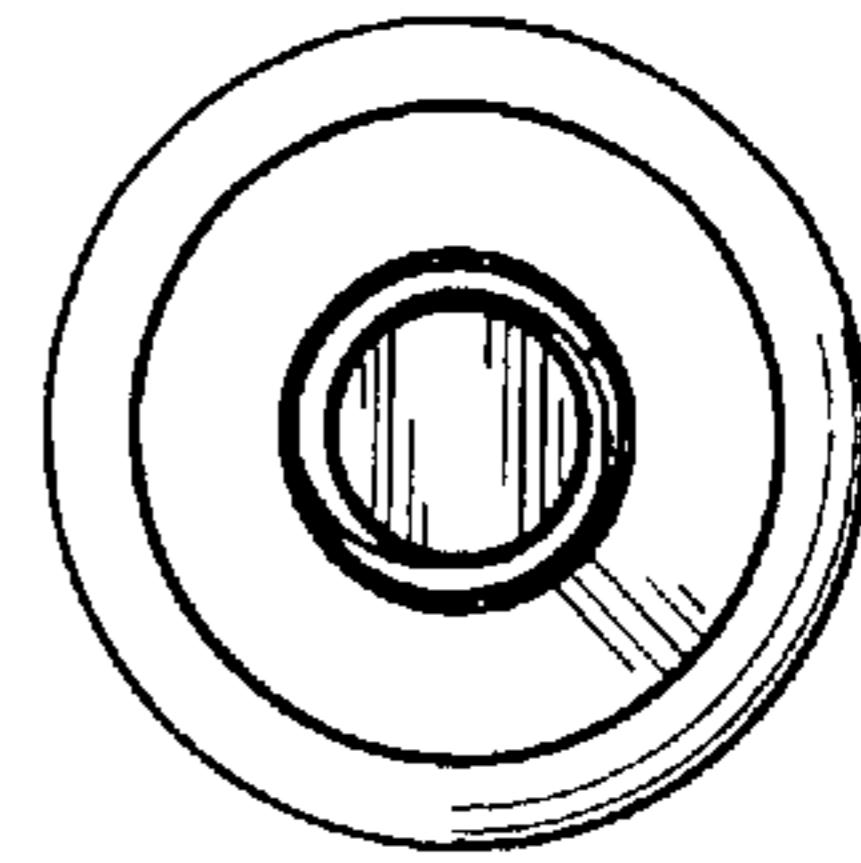

Figure 22

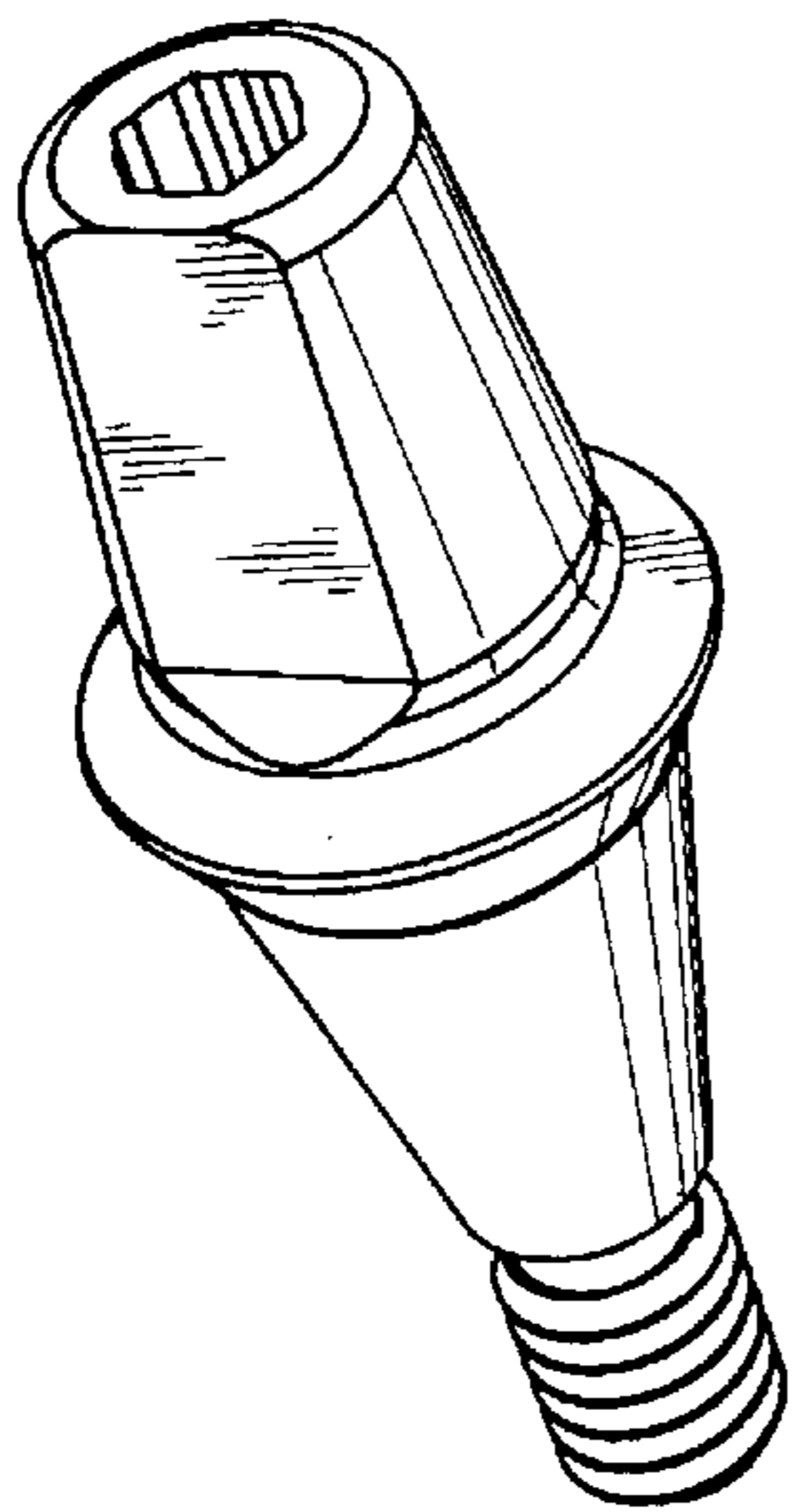

Figure 23

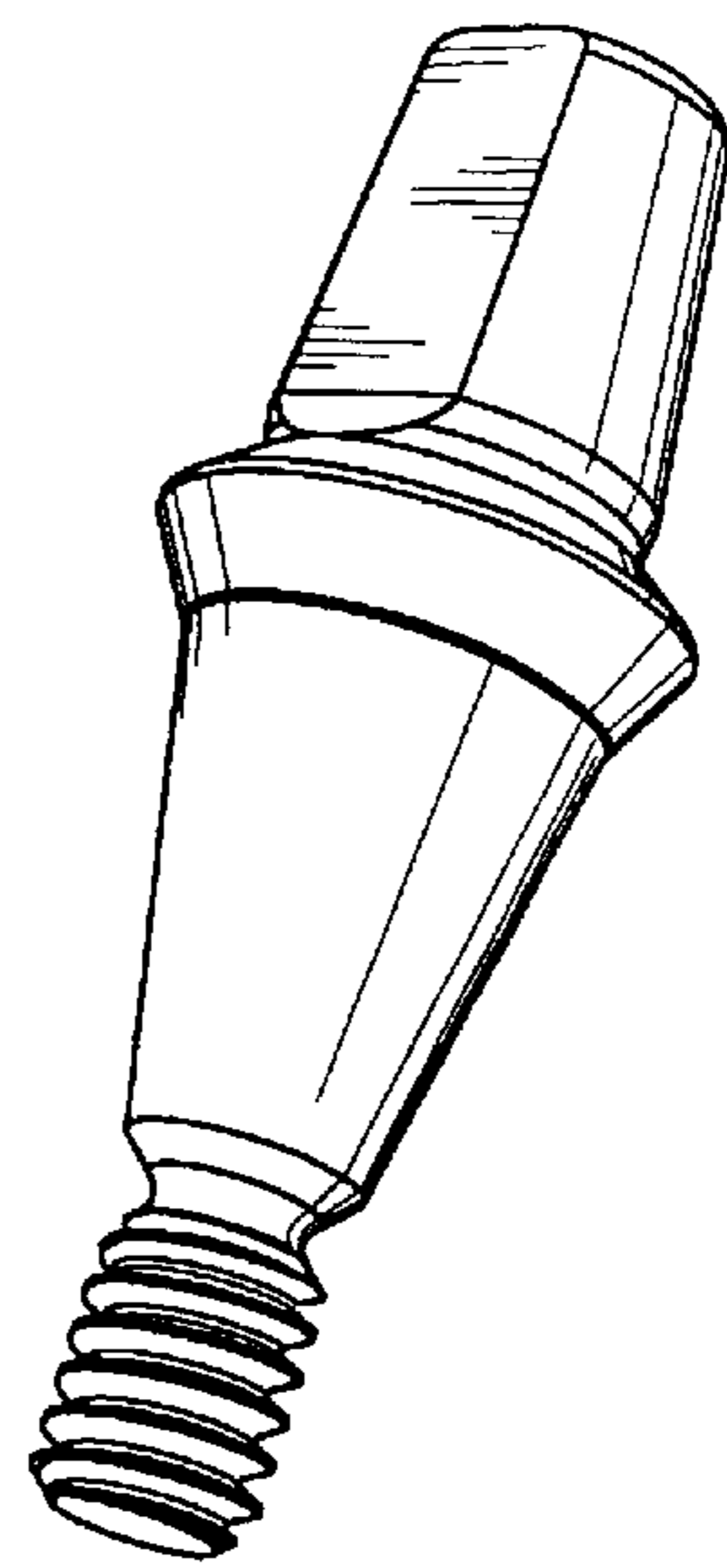

Figure 24

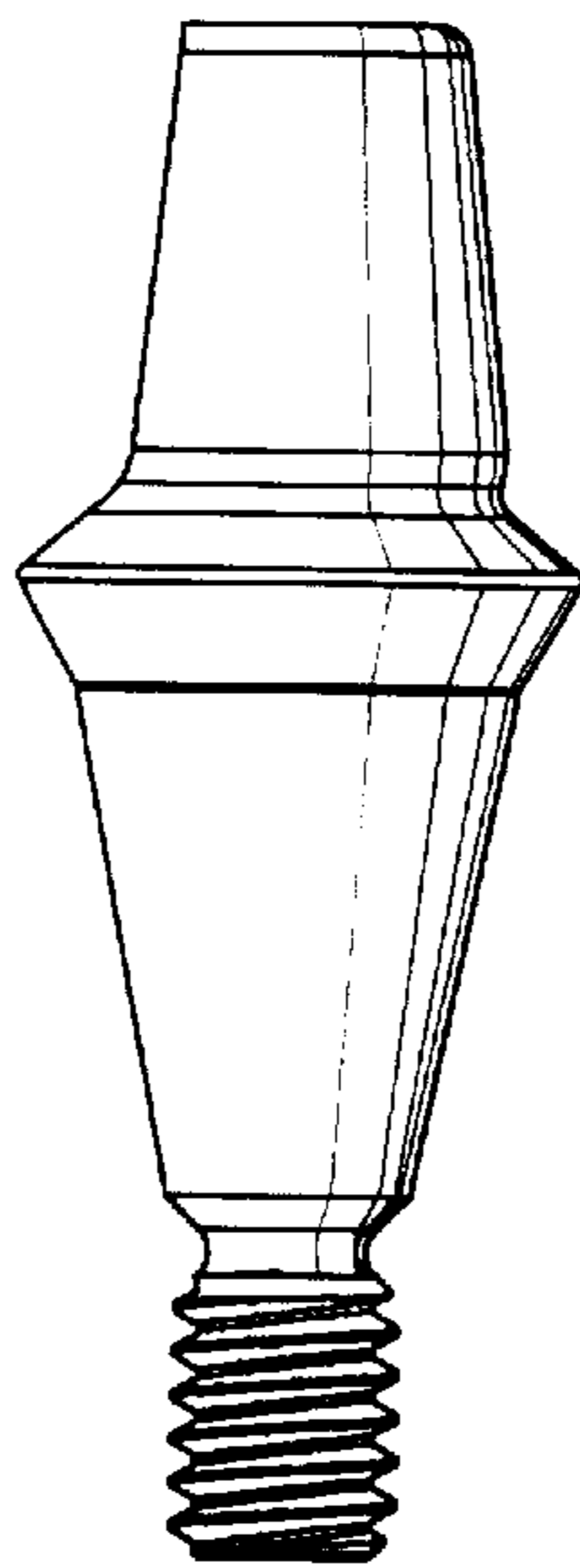

Figure 25

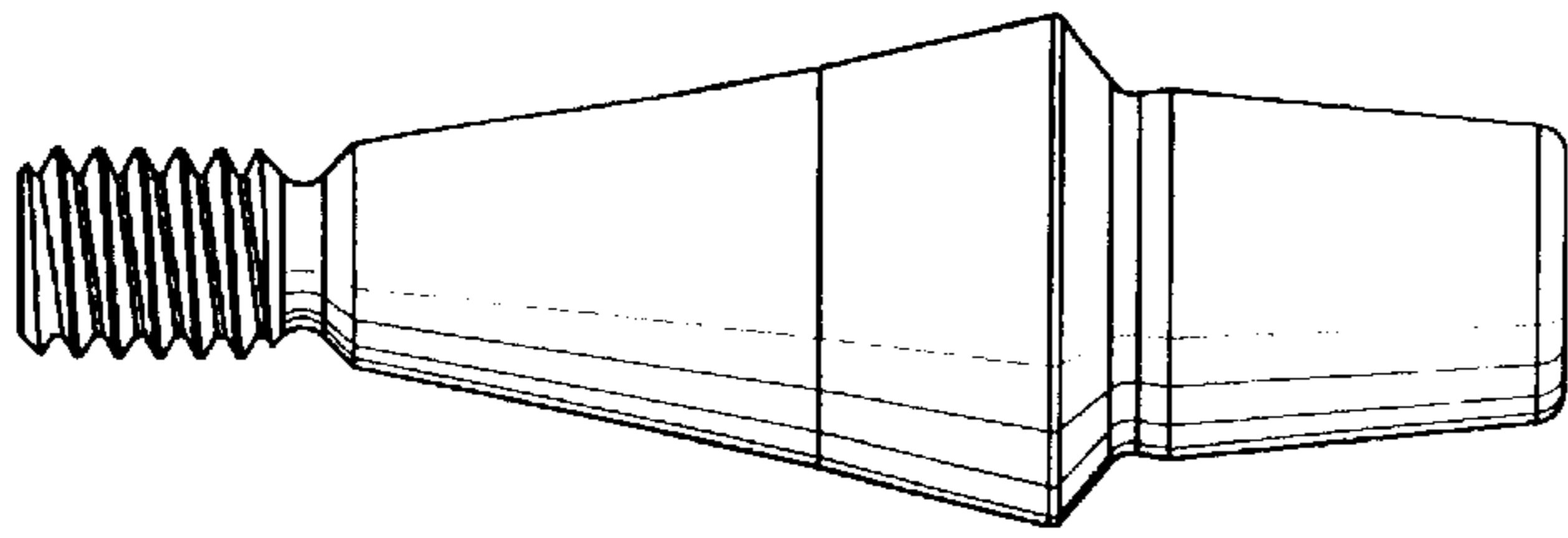

Figure 26

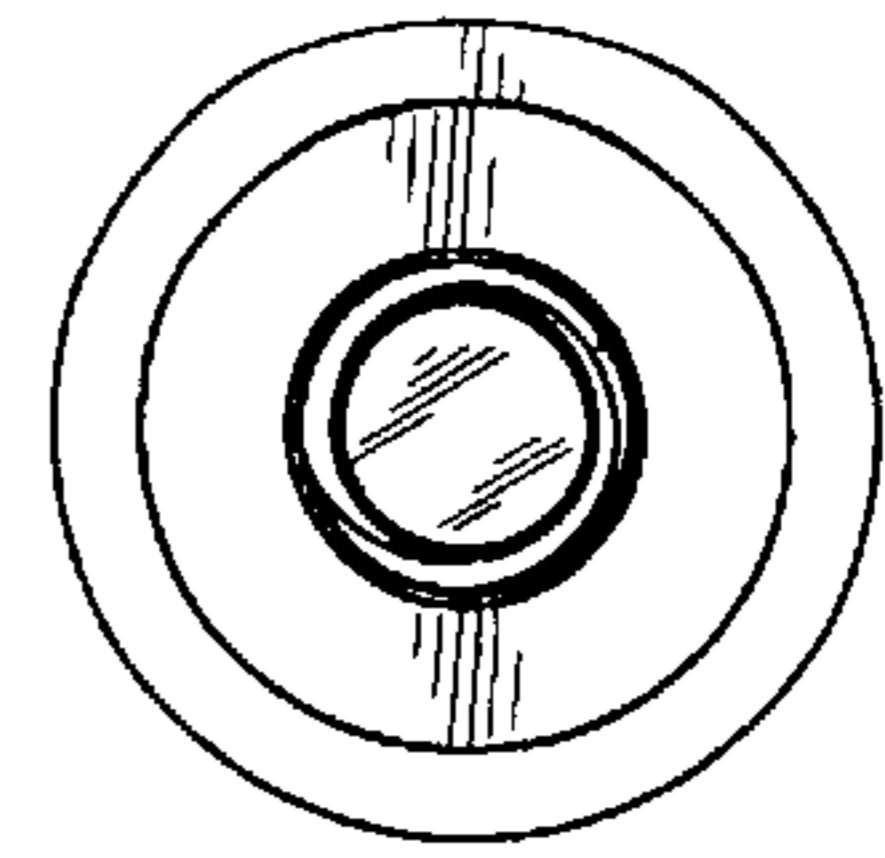

Figure 27

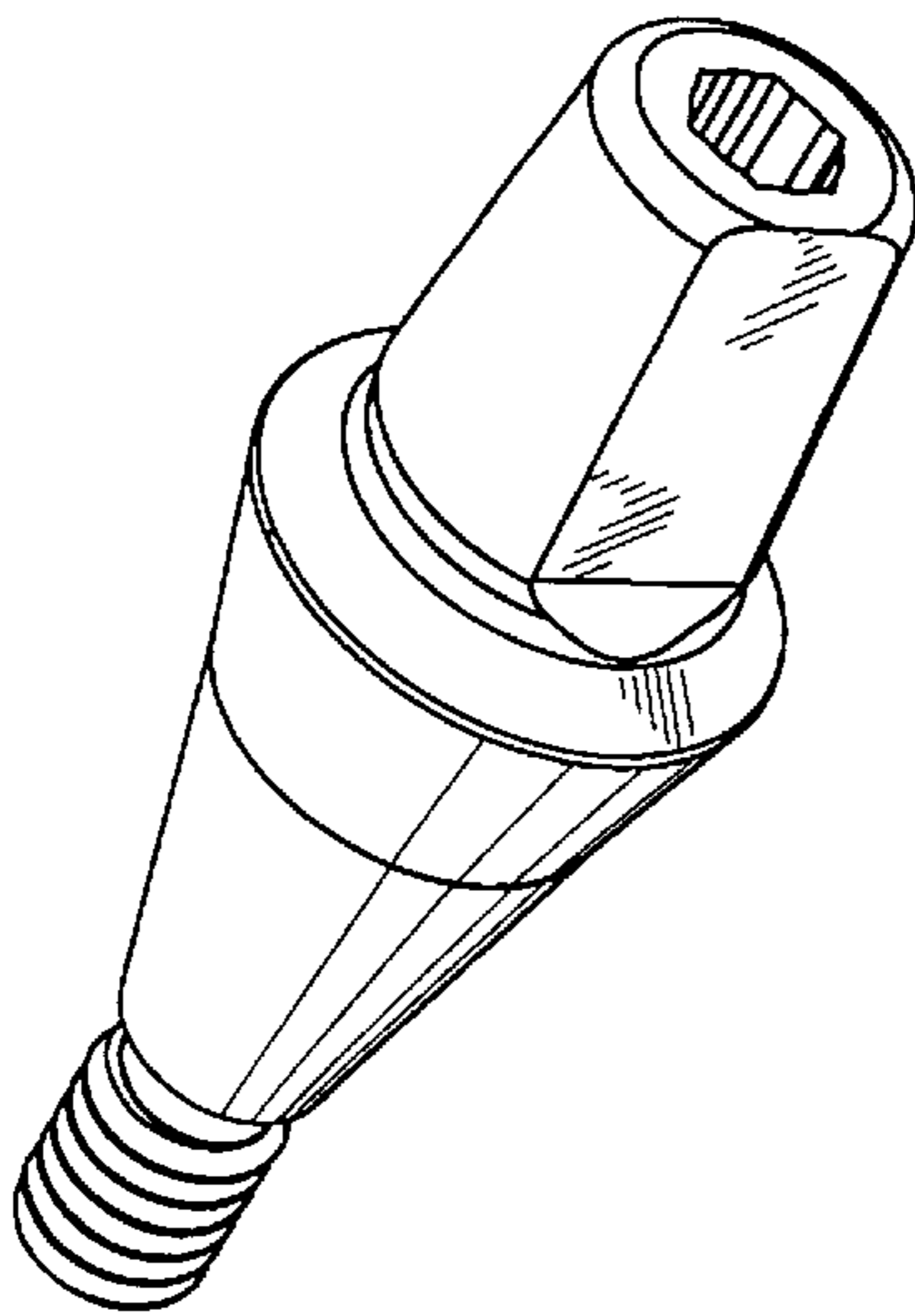

Figure 28

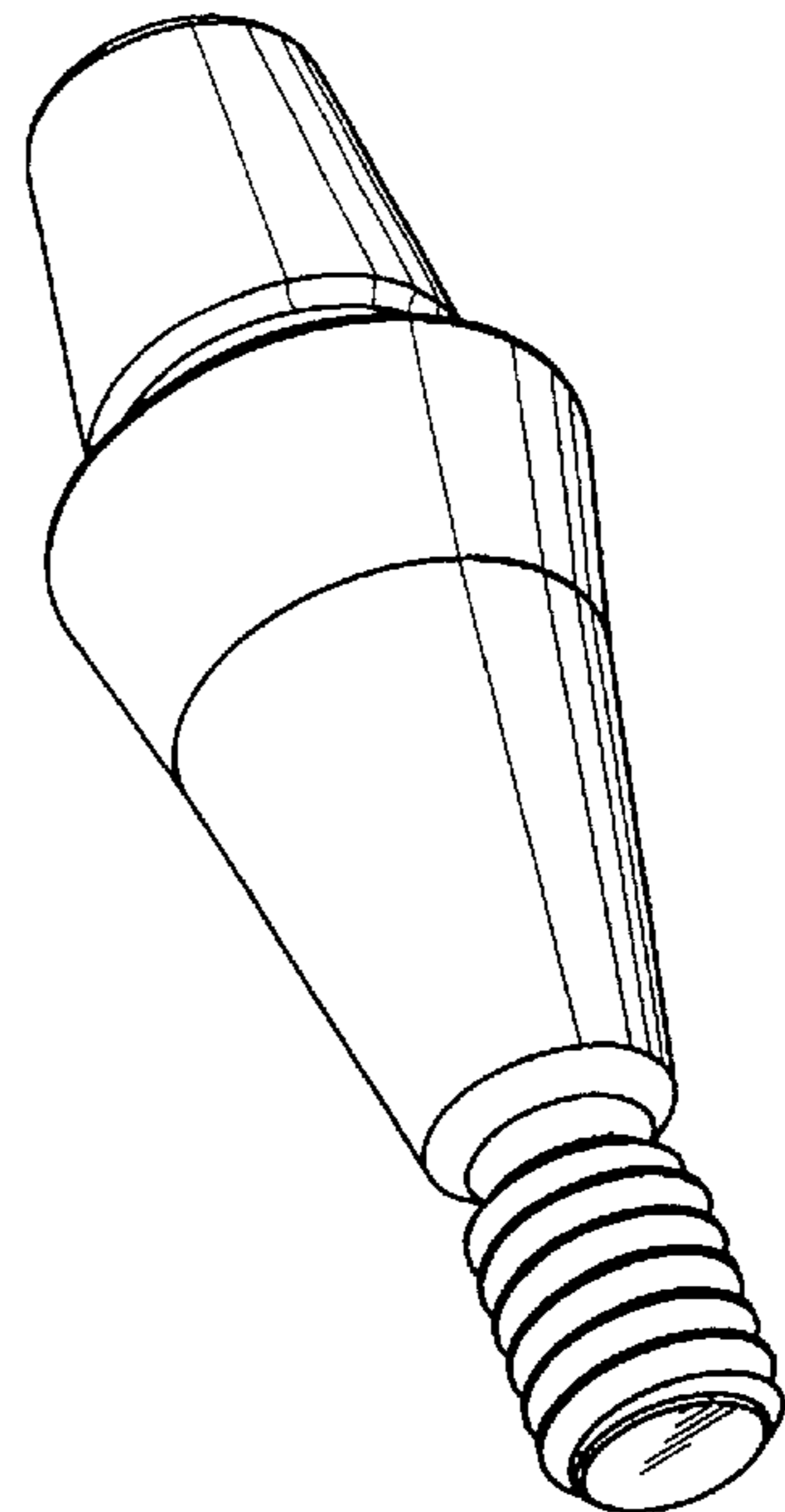

Figure 29

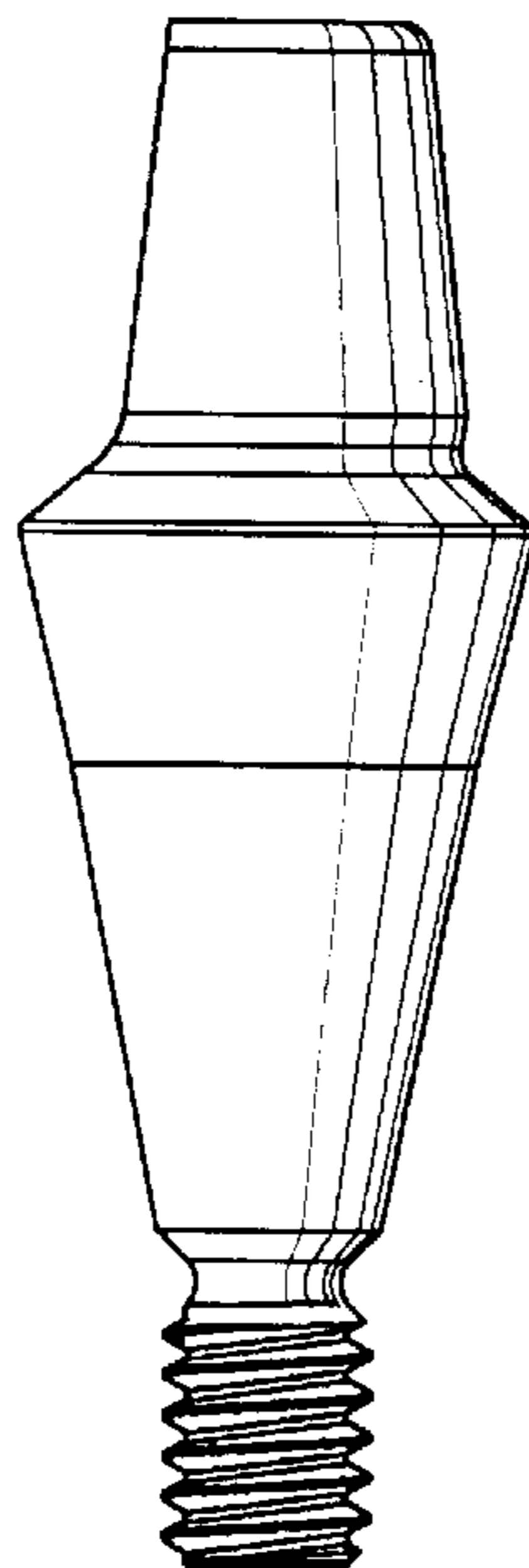

Figure 30

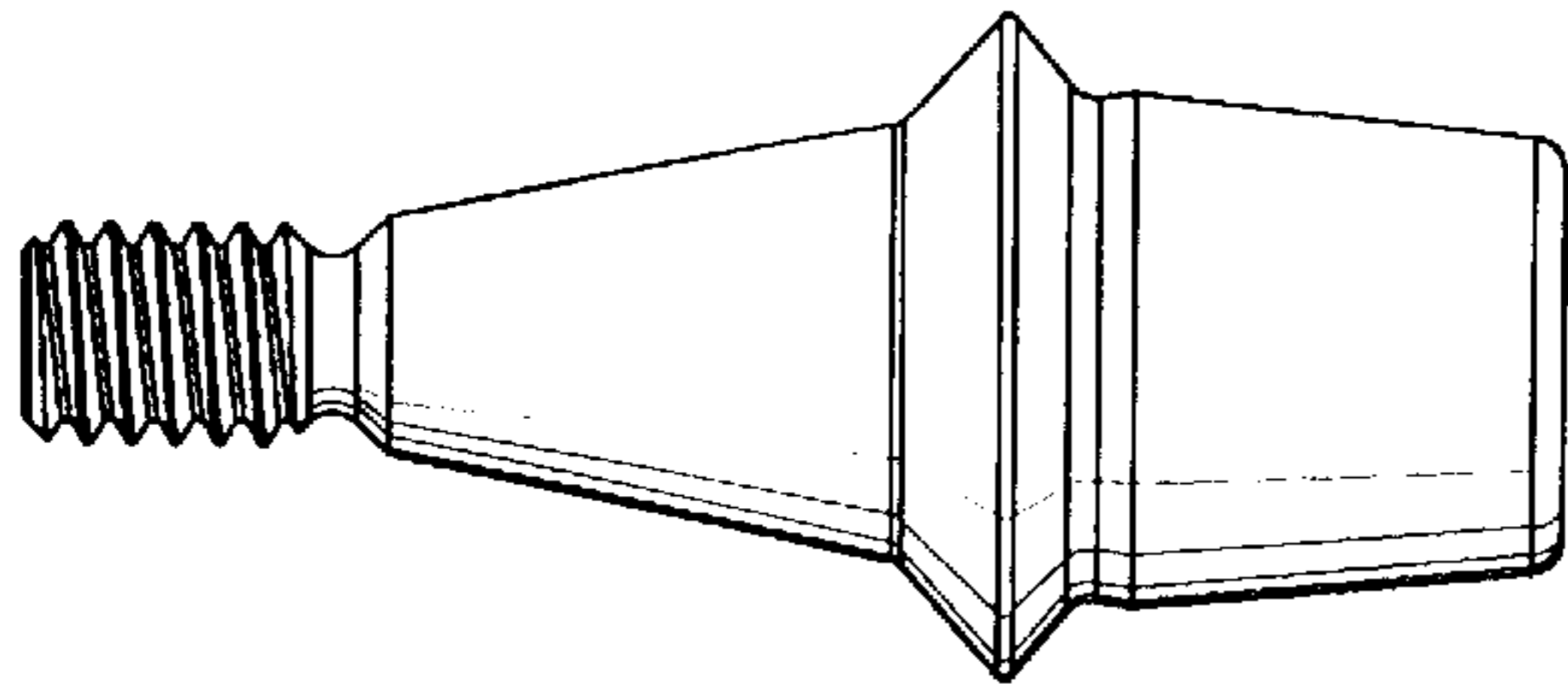

Figure 31

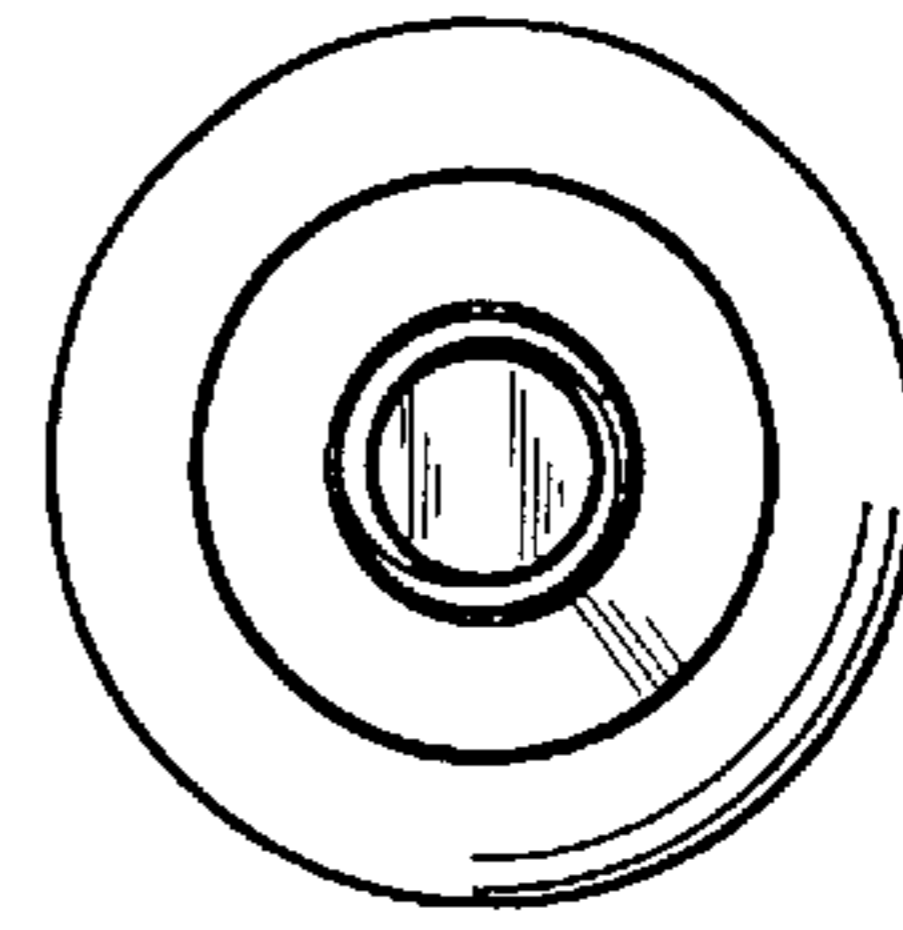

Figure 32

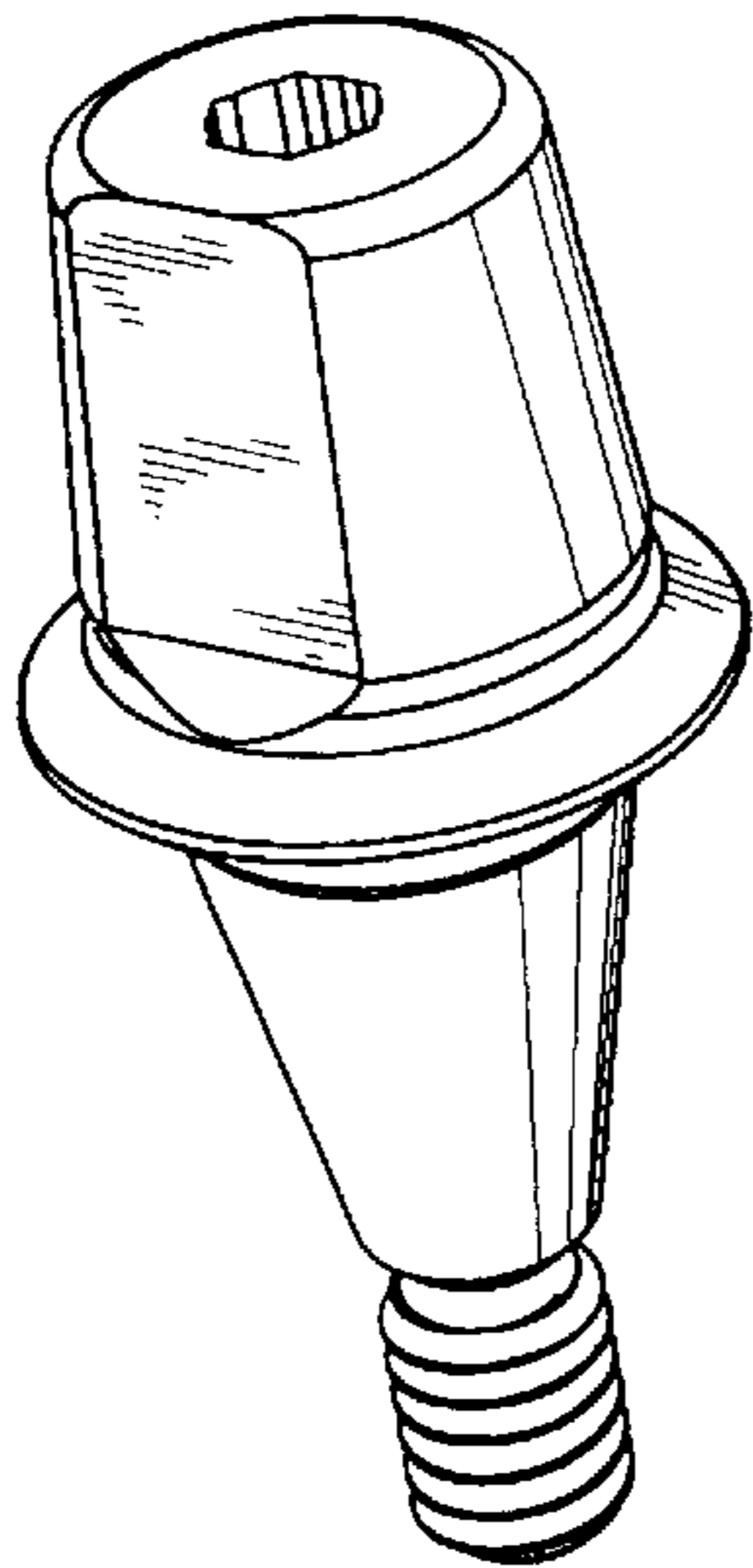

Figure 33

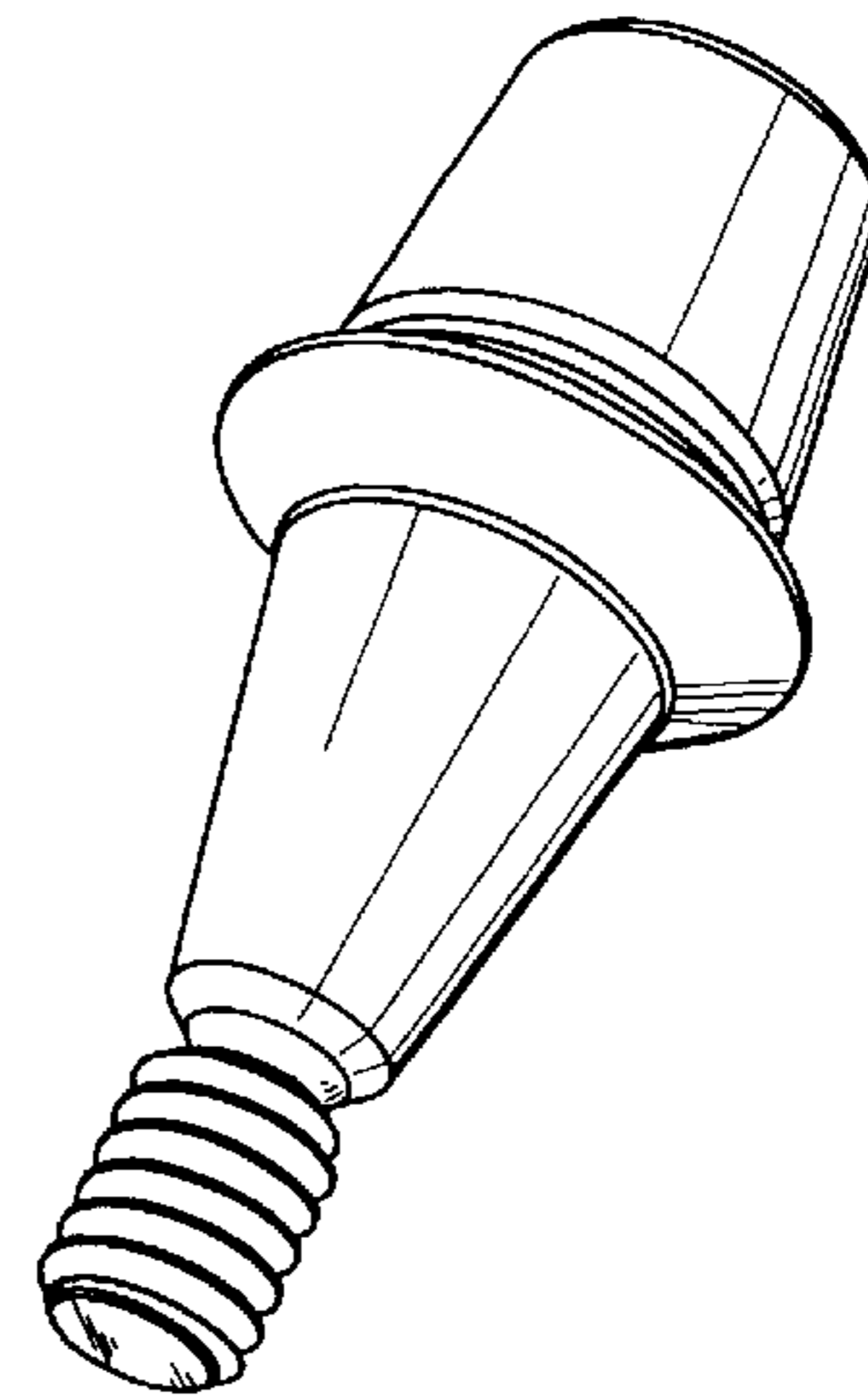

Figure 34

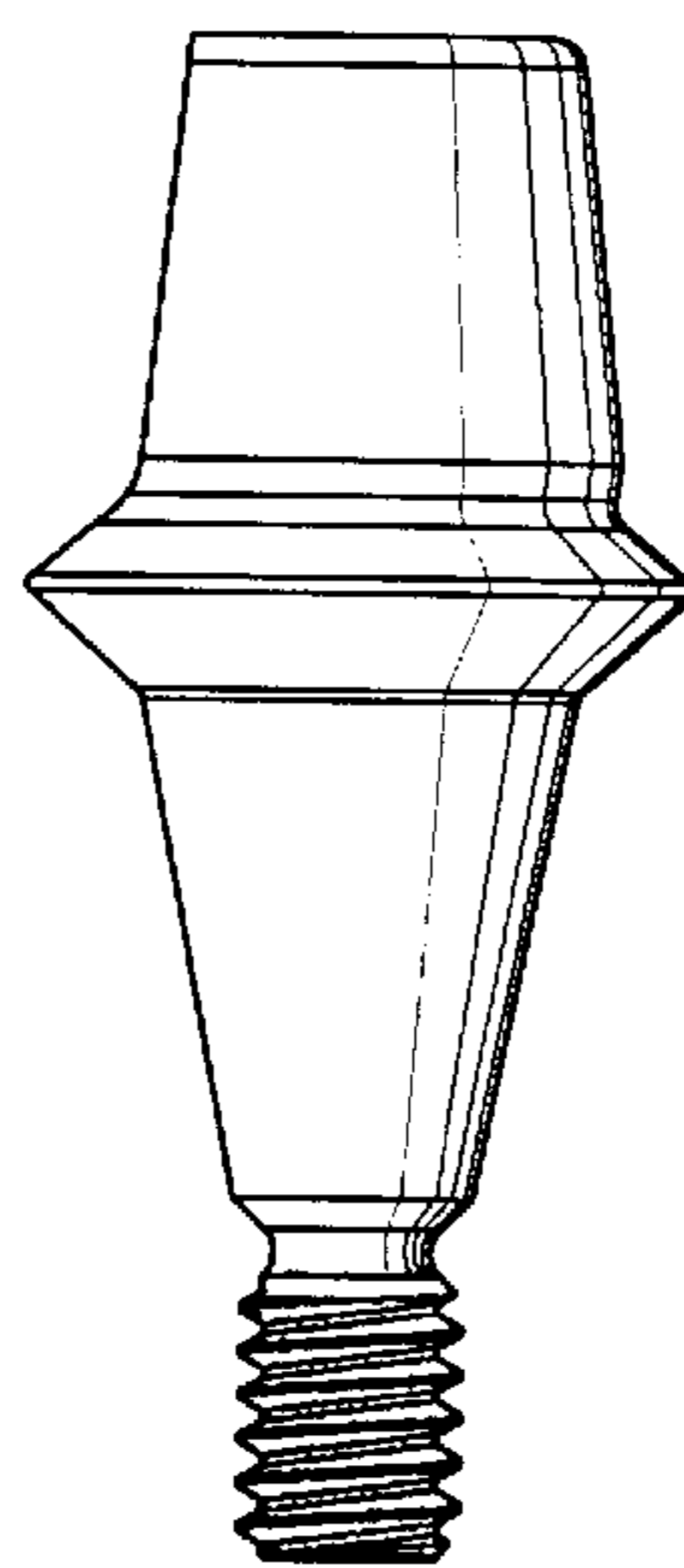

Figure 35

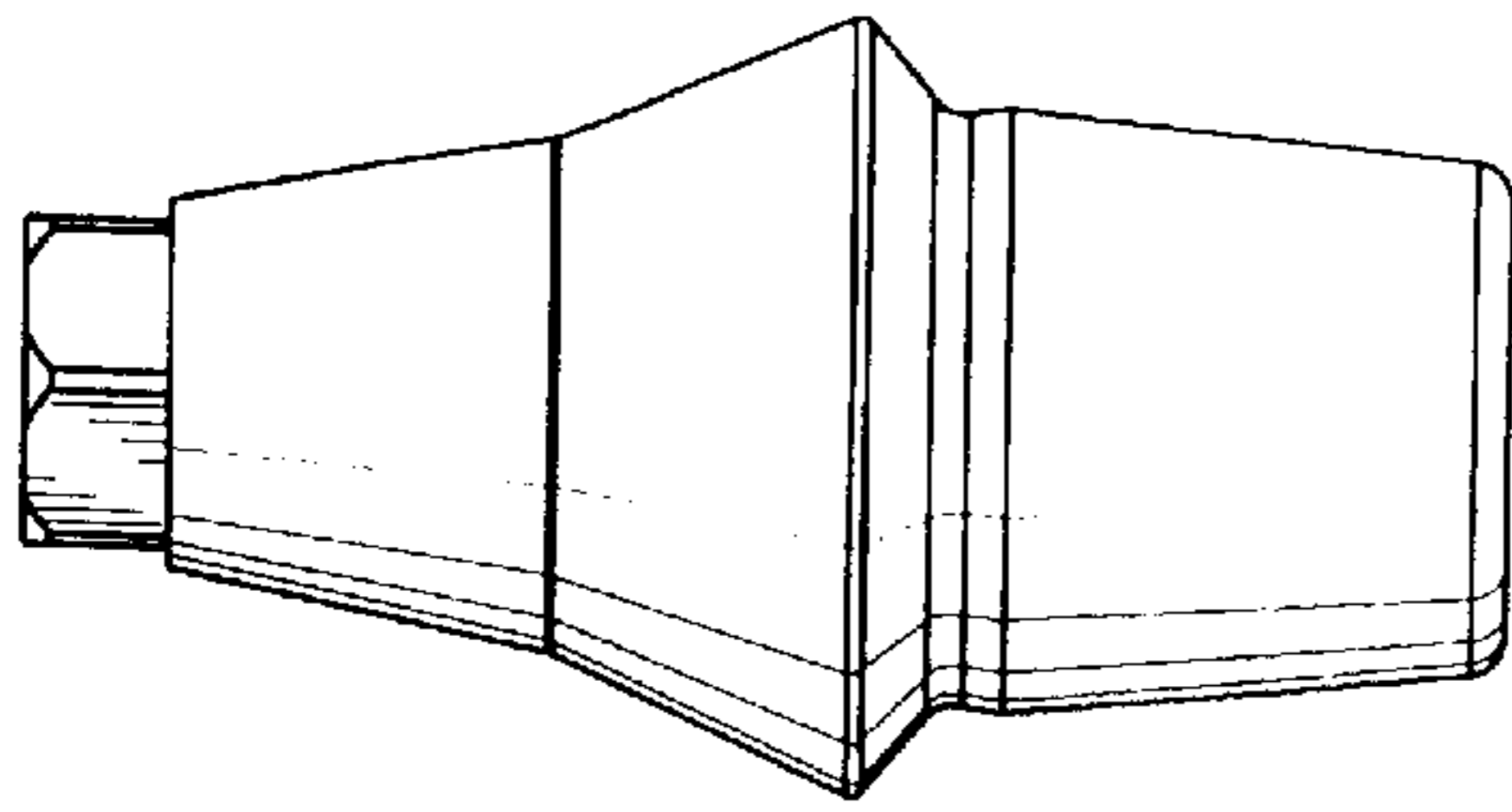

Figure 36

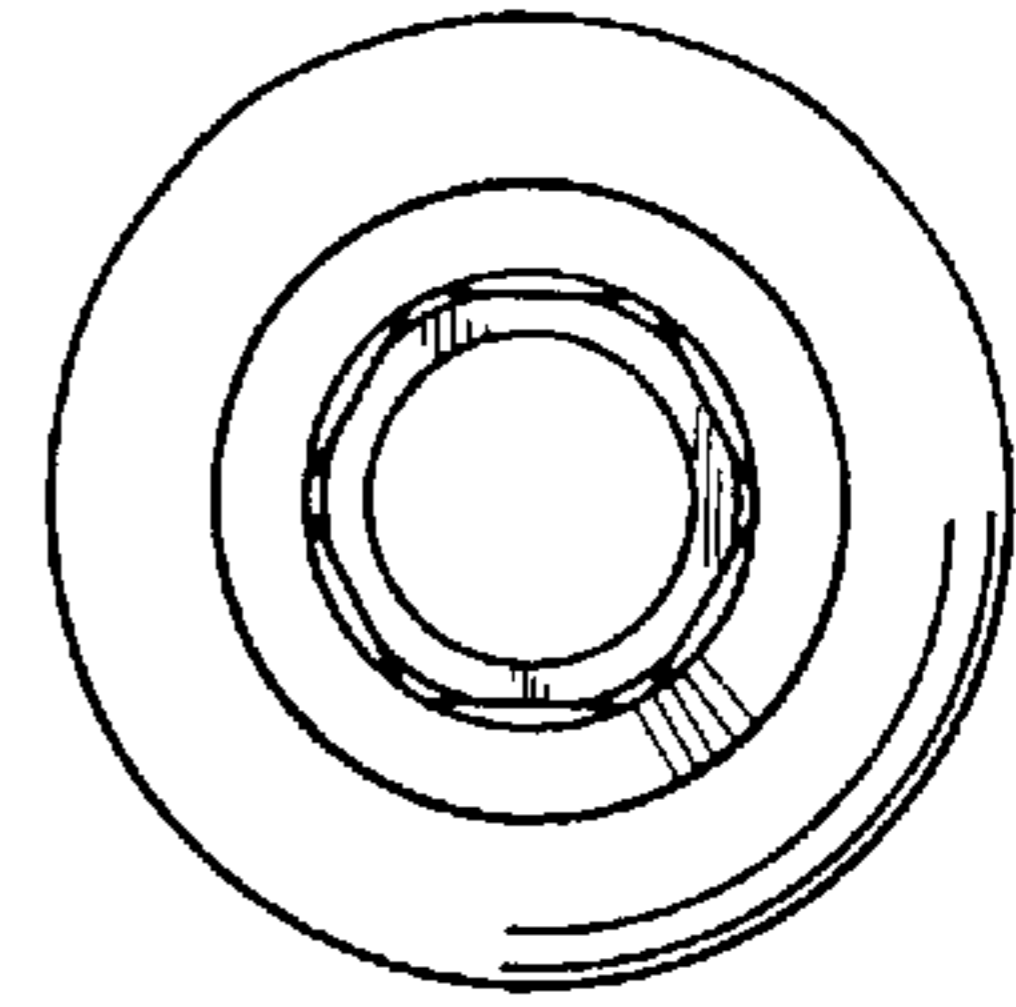

Figure 37

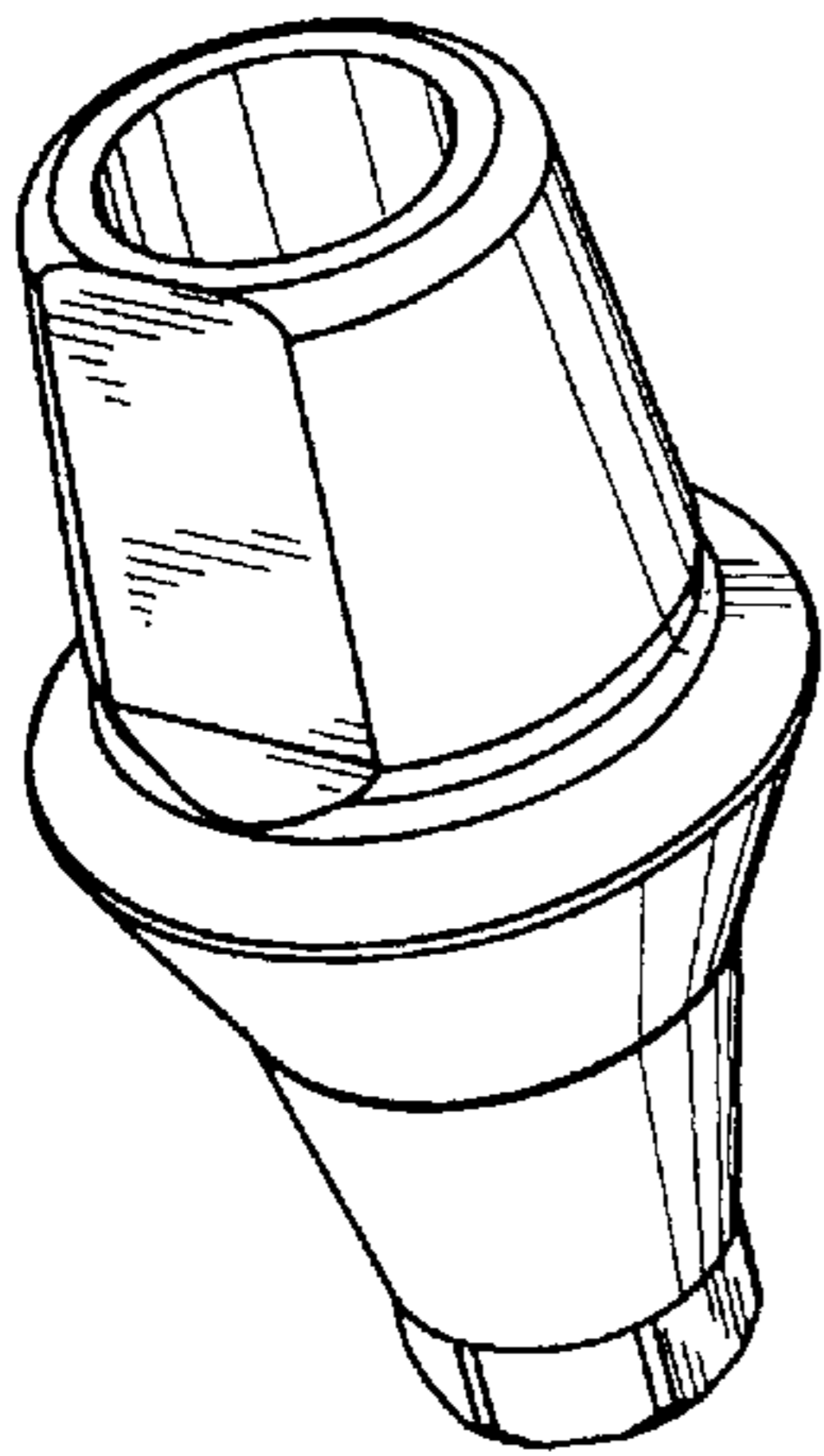

Figure 38

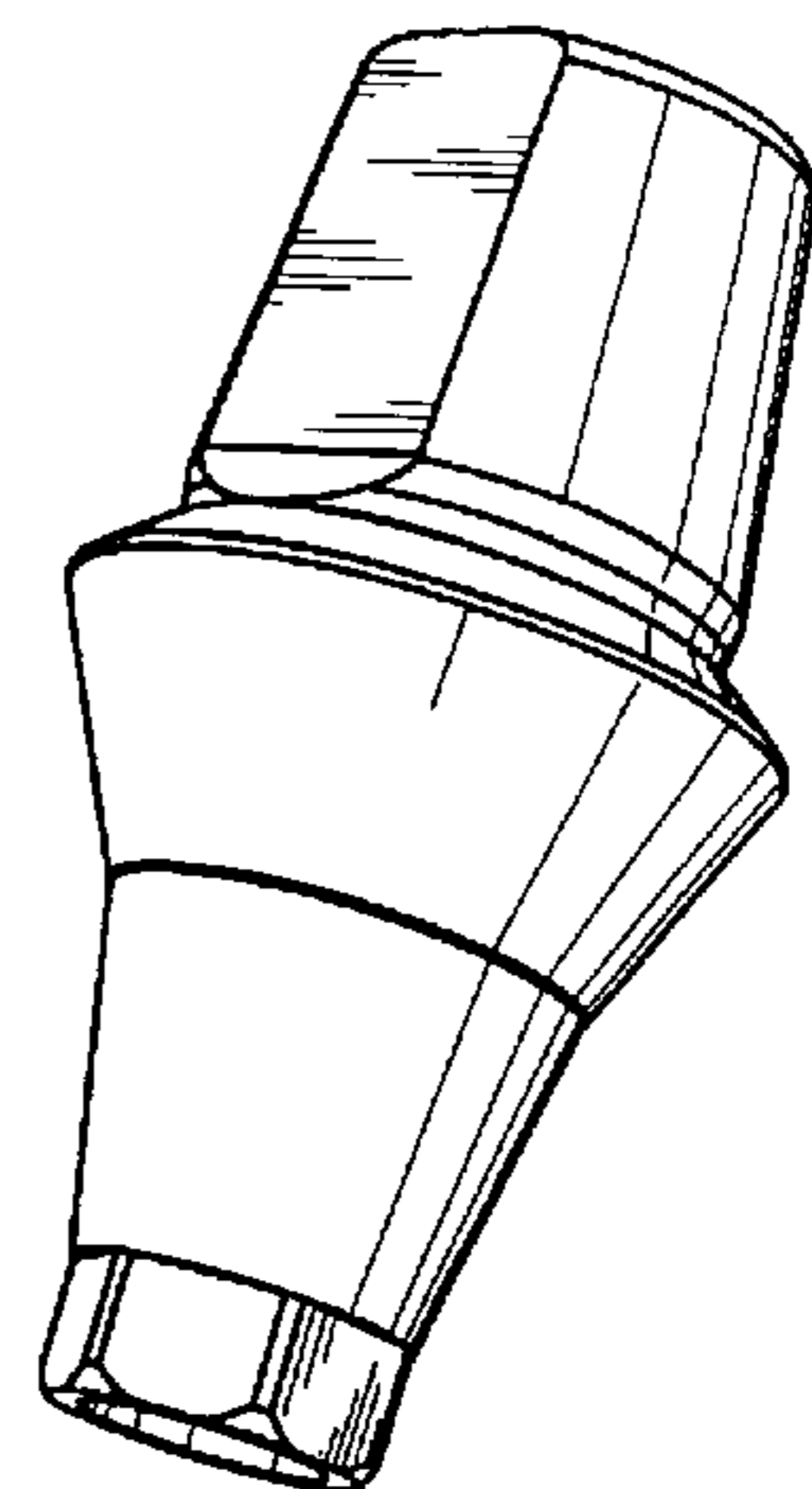

Figure 39

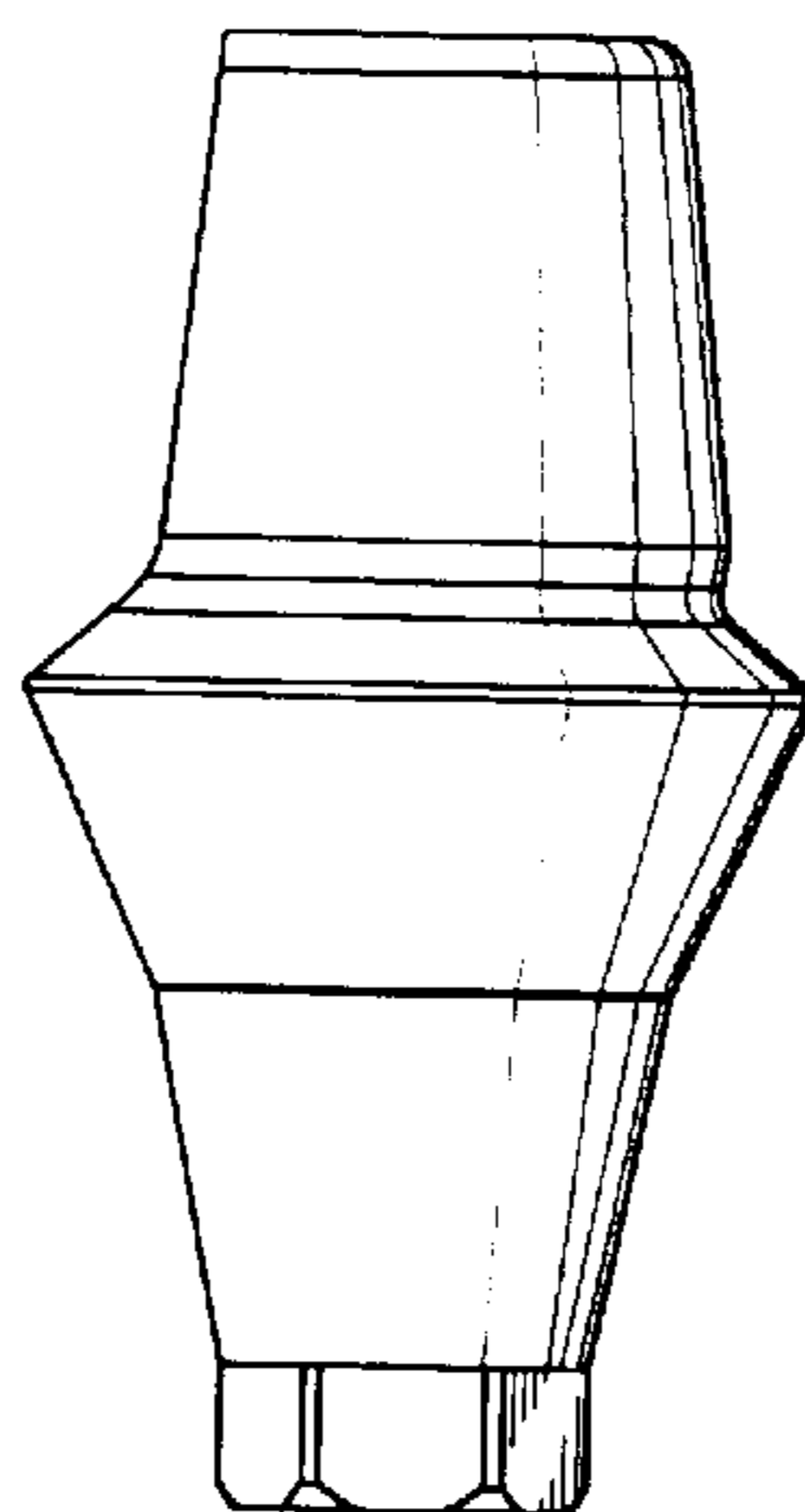

Figure 40

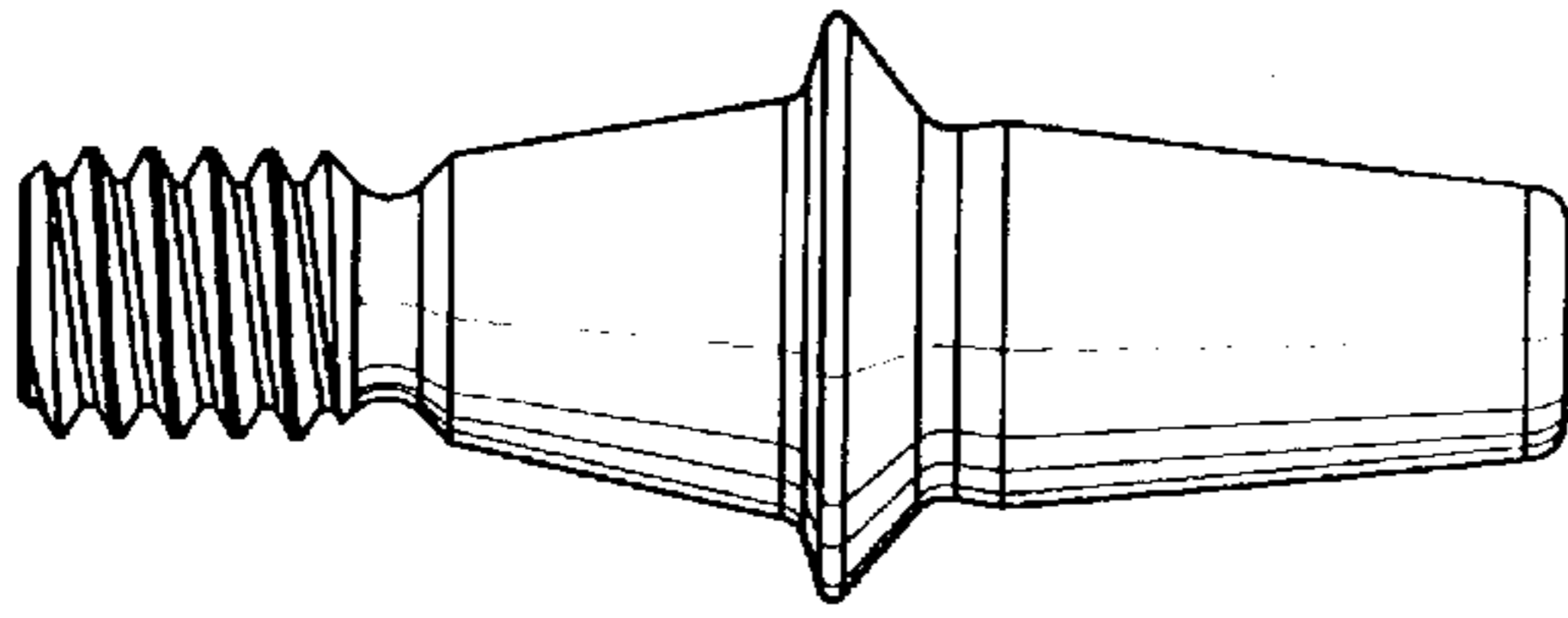

Figure 41

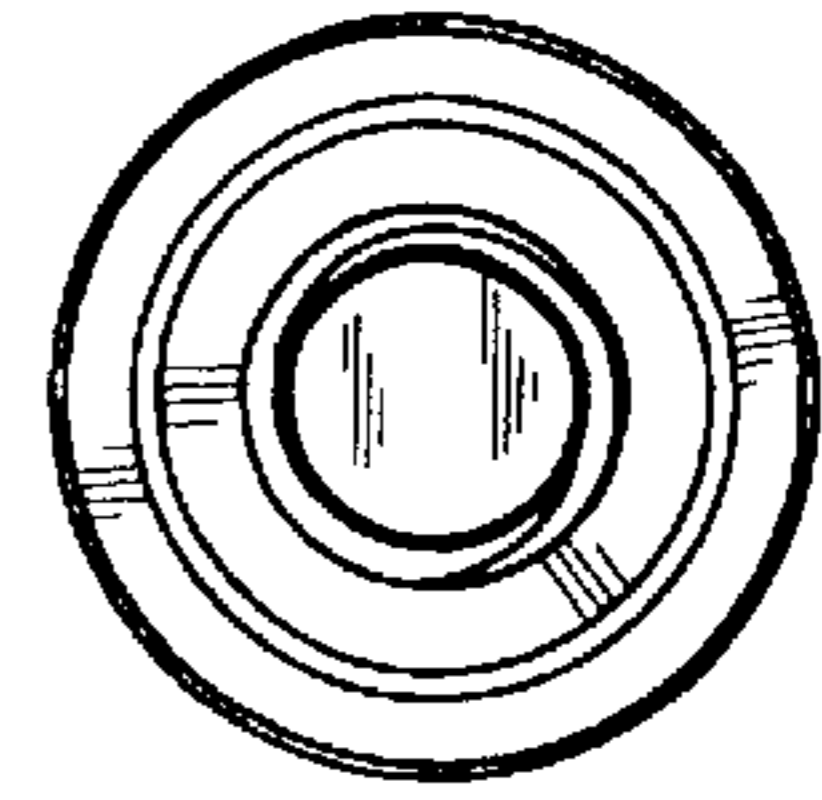

Figure 42

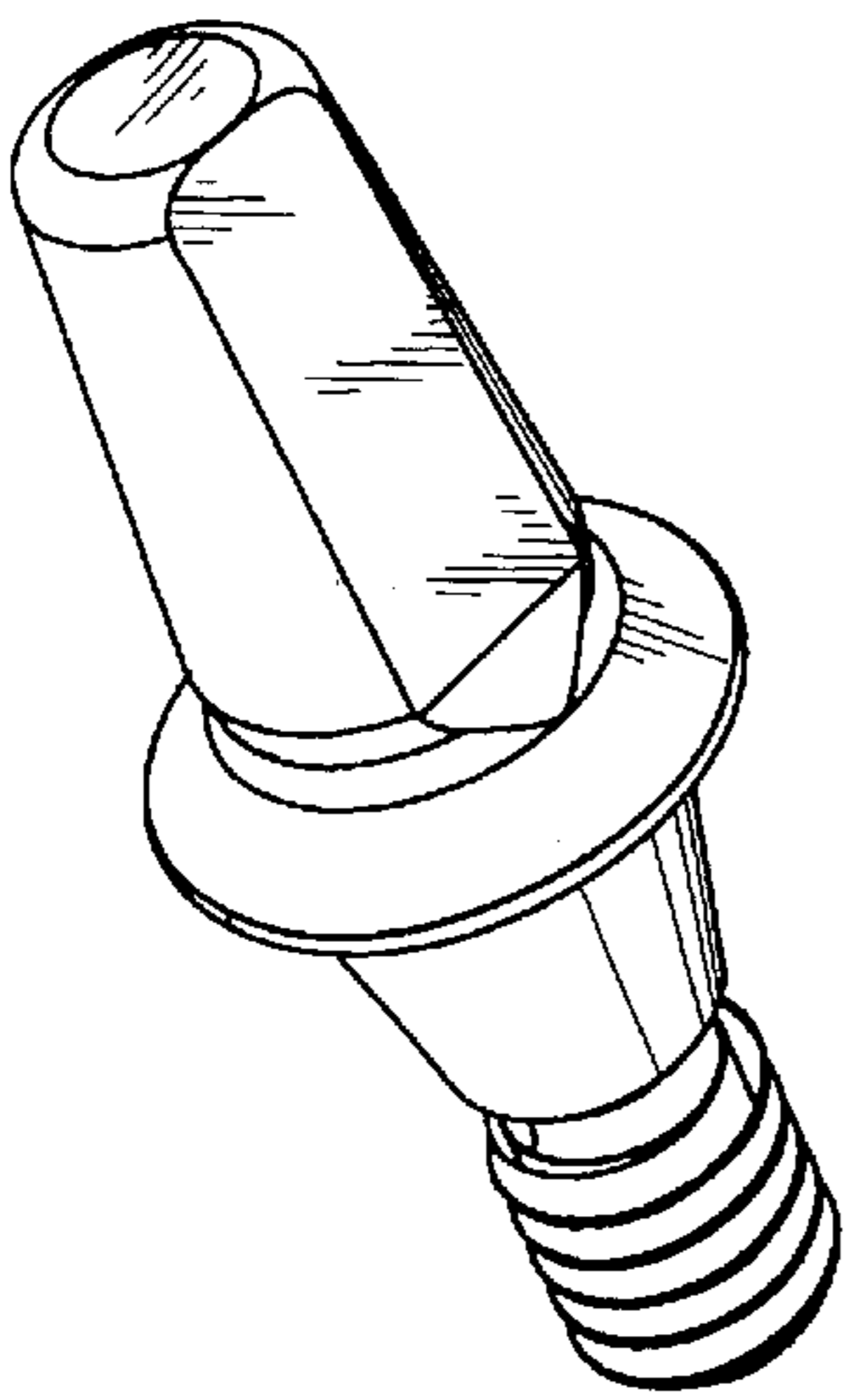

Figure 43

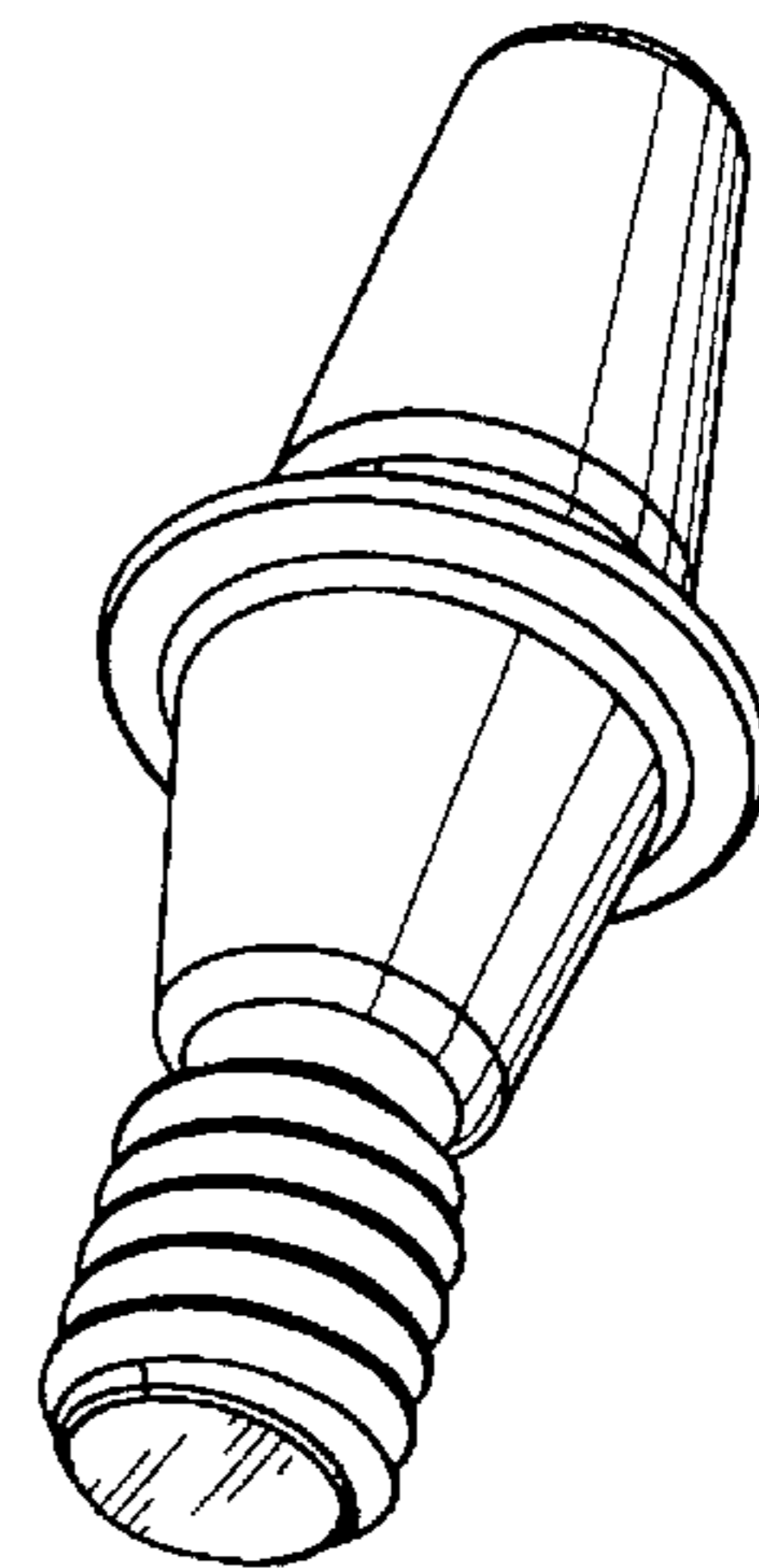

Figure 44

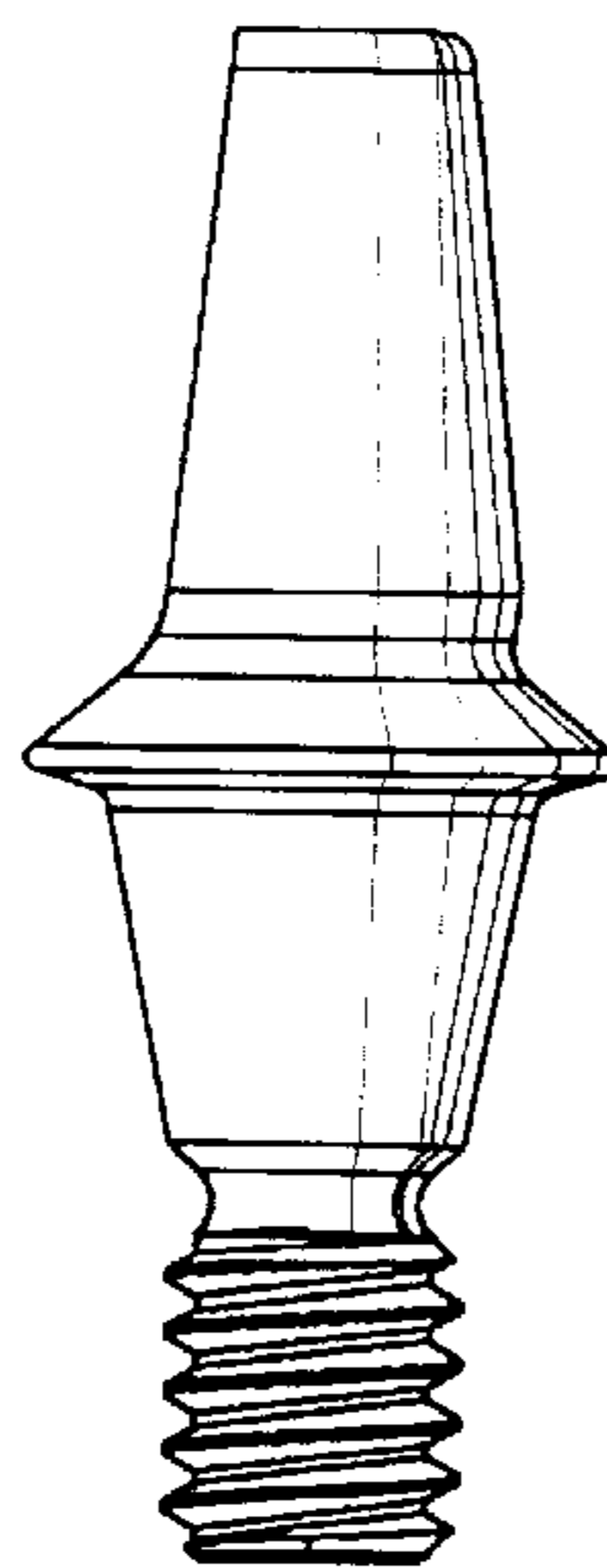

Figure 45

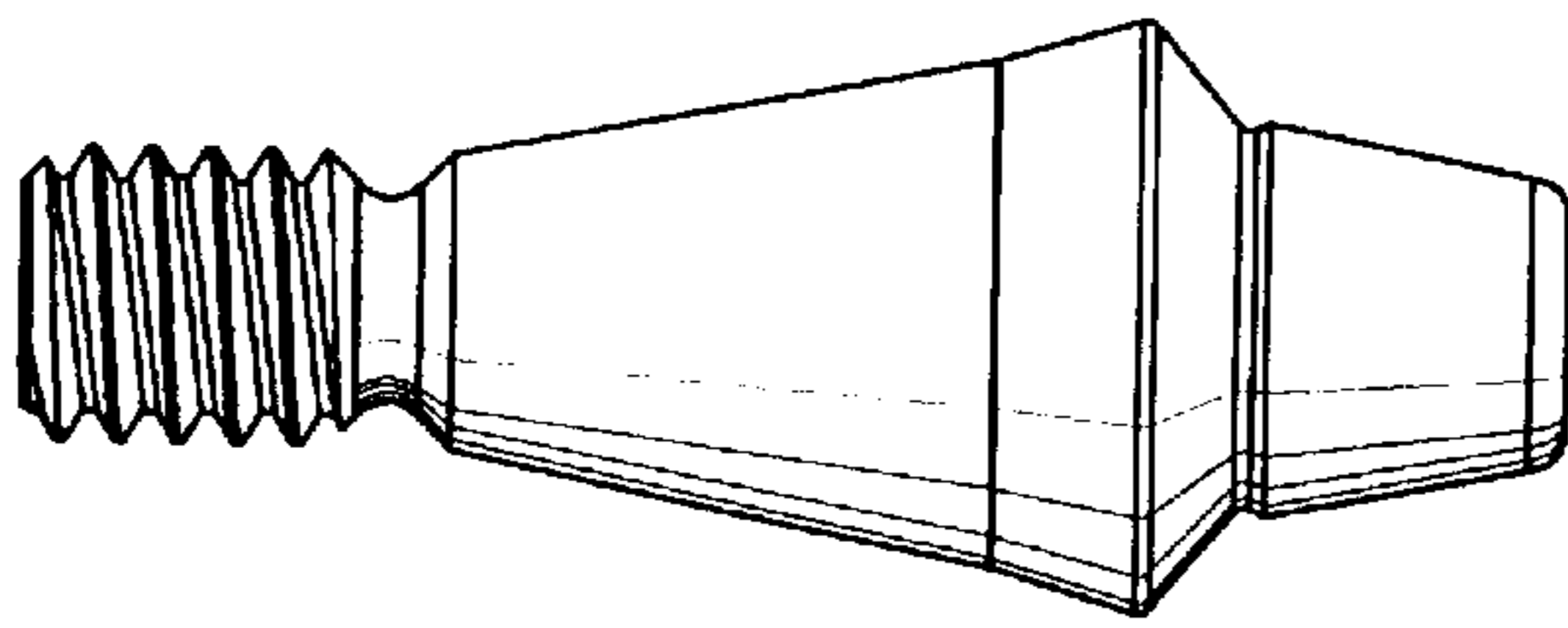

Figure 46

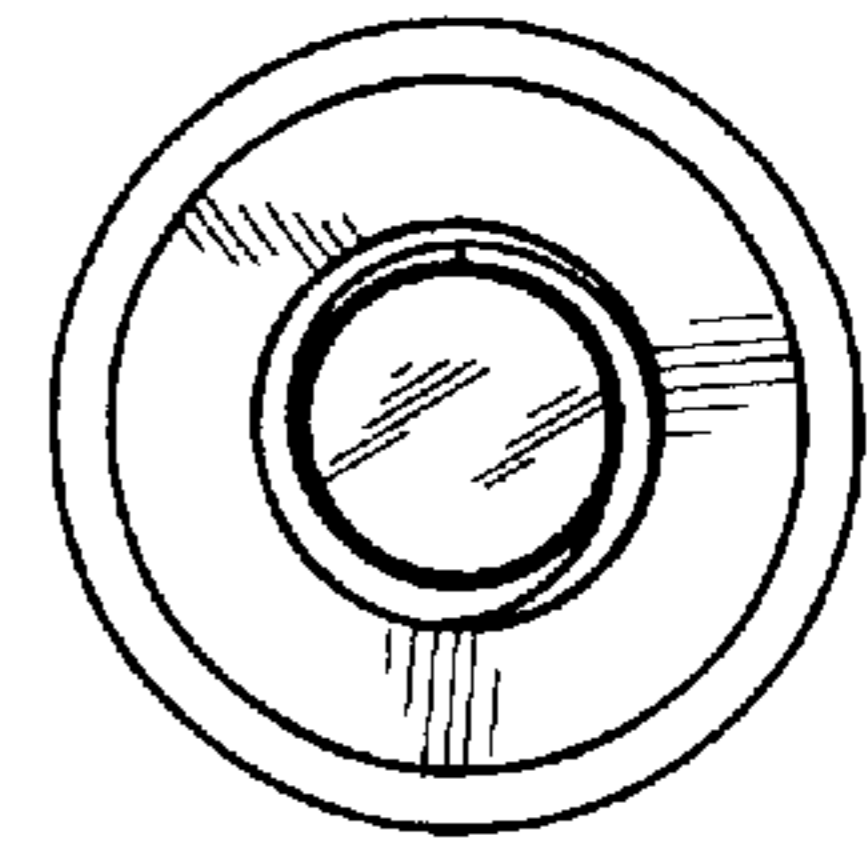

Figure 47

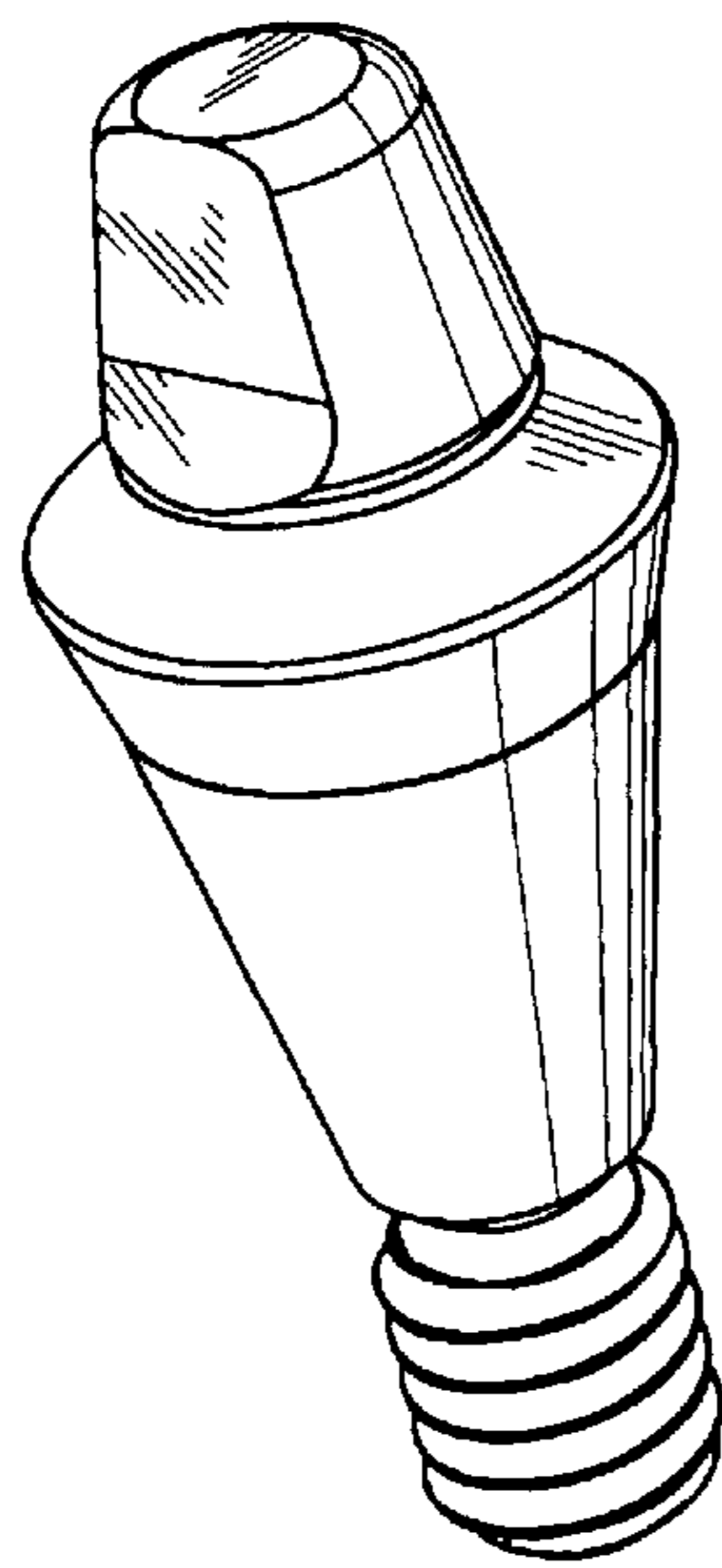

Figure 48

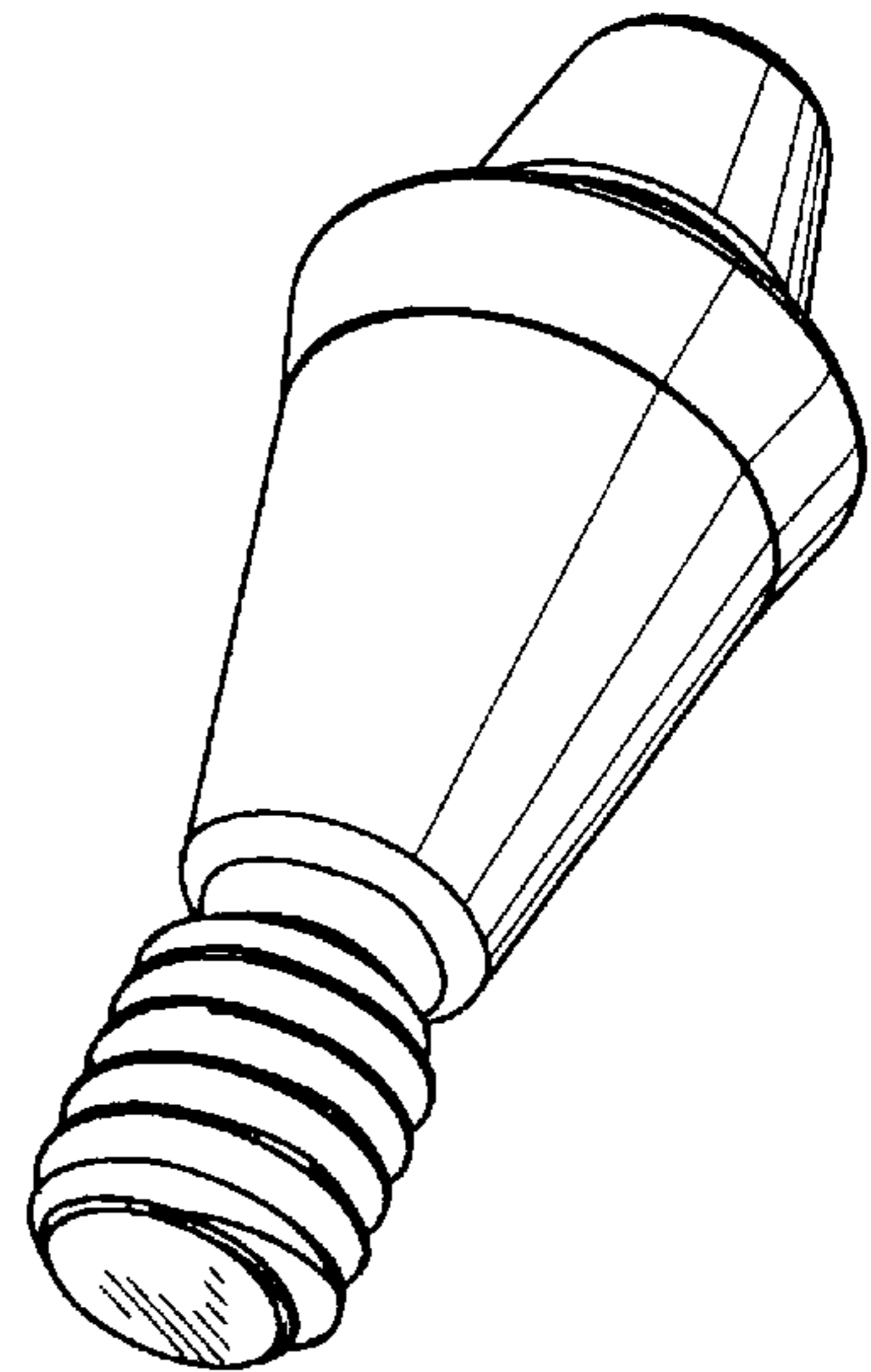

Figure 49

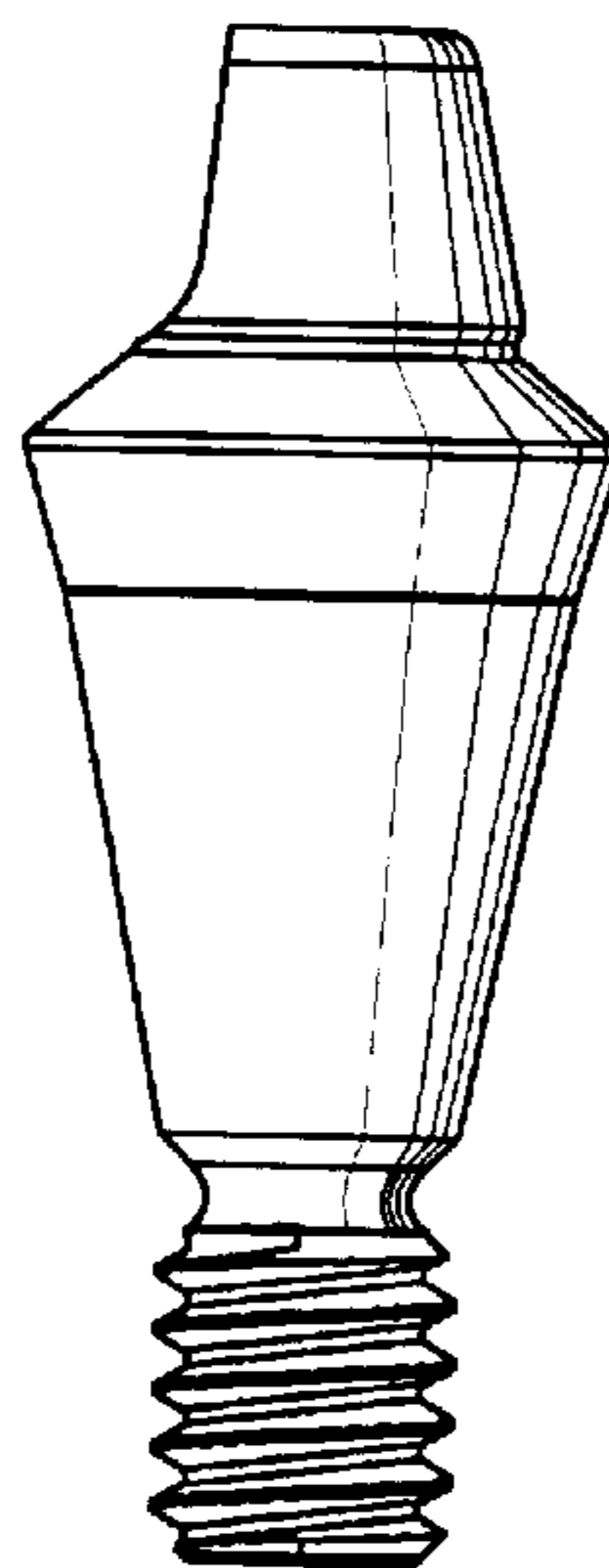

Figure 50