



US00D469196S

(12) **United States Design Patent**
Ohsawa et al.

(10) **Patent No.:** **US D469,196 S**
(45) **Date of Patent:** **** Jan. 21, 2003**

(54) **REAR COMBINATION LAMP OF A MOTOR VEHICLE**

(75) Inventors: **Hiroshi Ohsawa, Wako (JP); Shingo Yagihashi, Wako (JP)**

(73) Assignee: **Honda Giken Kogyo Kabushiki Kaisha, Tokyo (JP)**

(**) Term: **14 Years**

(21) Appl. No.: **29/139,619**

(22) Filed: **Apr. 4, 2001**

(30) **Foreign Application Priority Data**

Oct. 4, 2000 (JP) 2000-028048

(51) **LOC (7) Cl.** **26-06**

(52) **U.S. Cl.** **D26/35**

(58) **Field of Search** D26/28-36; D12/82, D12/86, 90, 91, 92; 362/459, 460, 465, 487, 497, 498, 499, 541, 542

(56) **References Cited**

U.S. PATENT DOCUMENTS

D295,084 S * 4/1988 Weber D26/35
D345,331 S * 3/1994 Smith D26/35

D449,393 S * 10/2001 Yamamoto et al. D26/28

* cited by examiner

Primary Examiner—Marcus A. Jackson

(74) *Attorney, Agent, or Firm*—Arent Fox Kintner Plotkin & Kahn, PLLC

(57) **CLAIM**

The ornamental design for a rear combination lamp of a motor vehicle, as shown and described.

DESCRIPTION

FIG. 1 is a front view of a rear combination lamp of a motor vehicle showing our new design with the broken line showing for illustrative purposes only and forming no part of the claimed design;

FIG. 2 is a rear view thereof;

FIG. 3 is a plan view thereof;

FIG. 4 is a bottom view thereof;

FIG. 5 is a right side view thereof, the left side being identical;

FIG. 6 is a perspective view thereof; and,

FIG. 7 is a perspective view of an automobile showing the lamp mounted thereon, the automobile is shown in broken lines for illustrative purposes and forms no part of the claimed design.

1 Claim, 3 Drawing Sheets

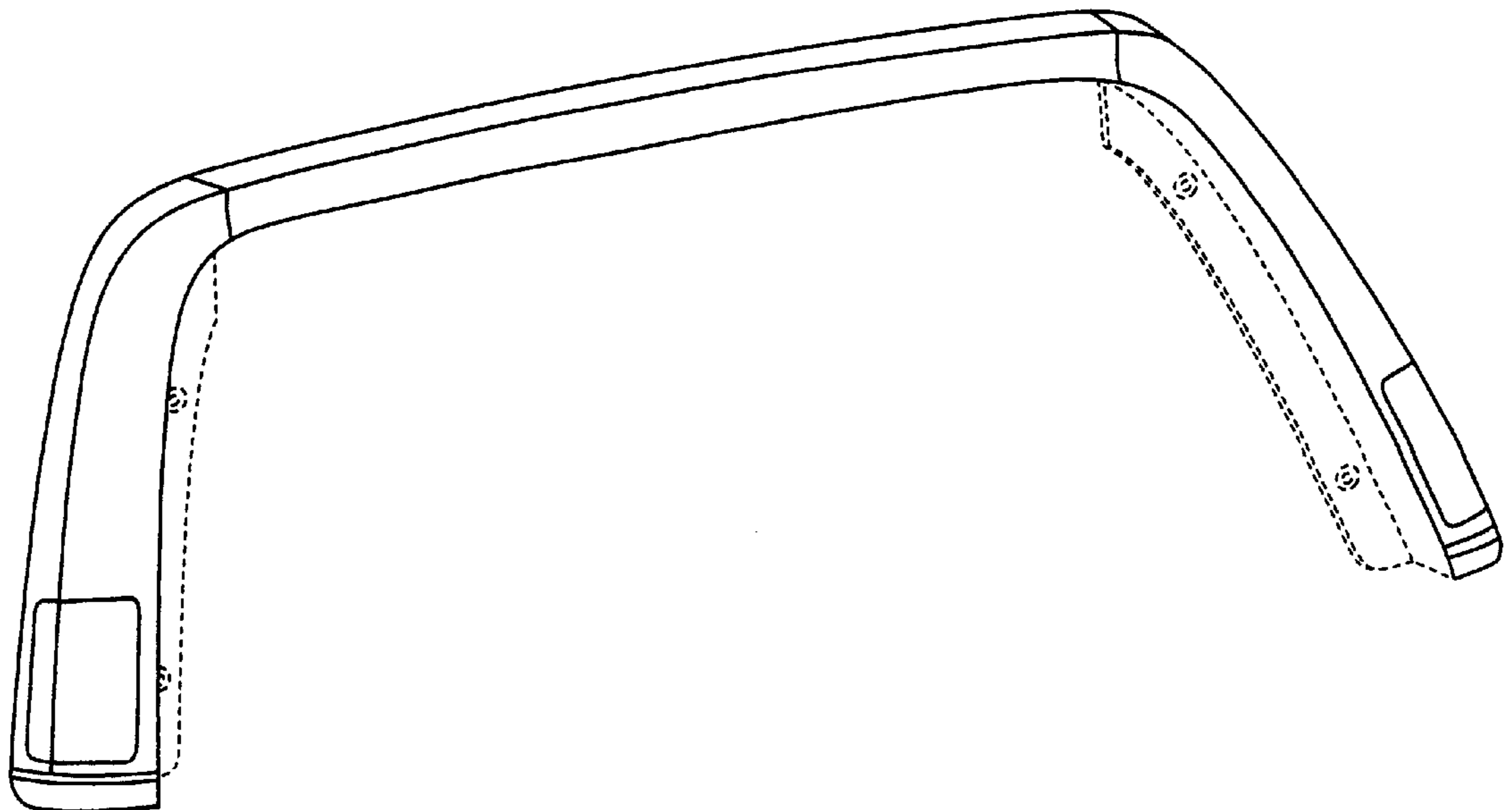

FIG. 1

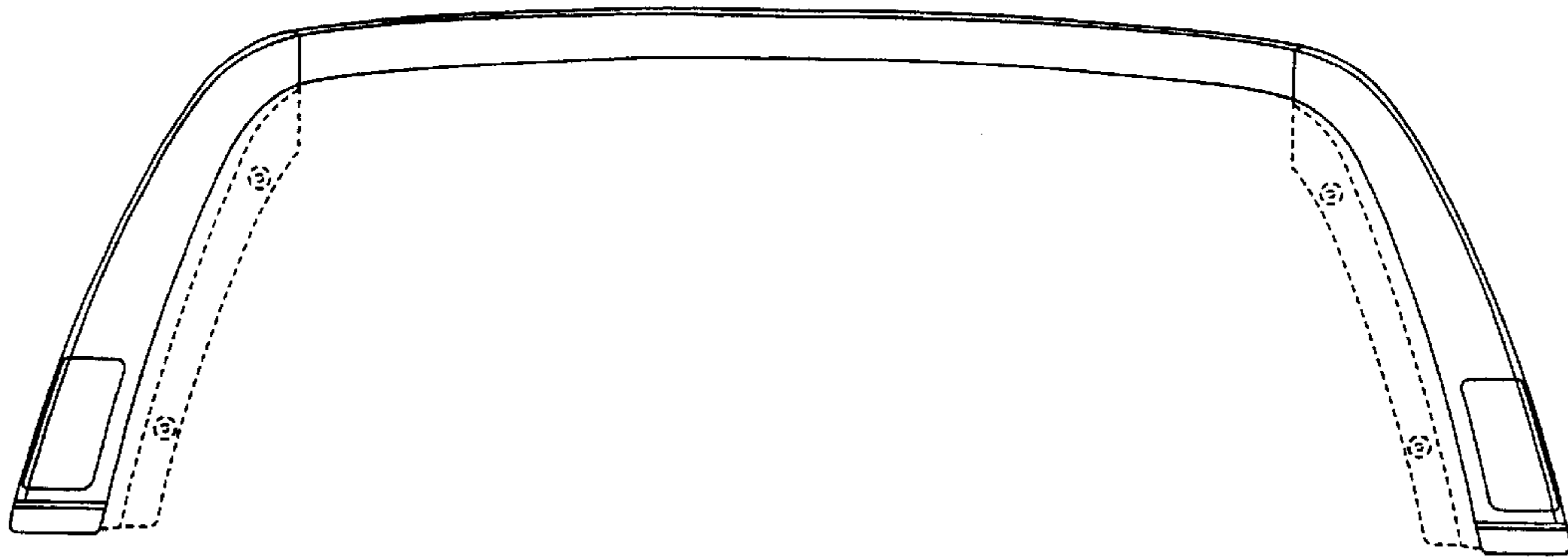

FIG. 2

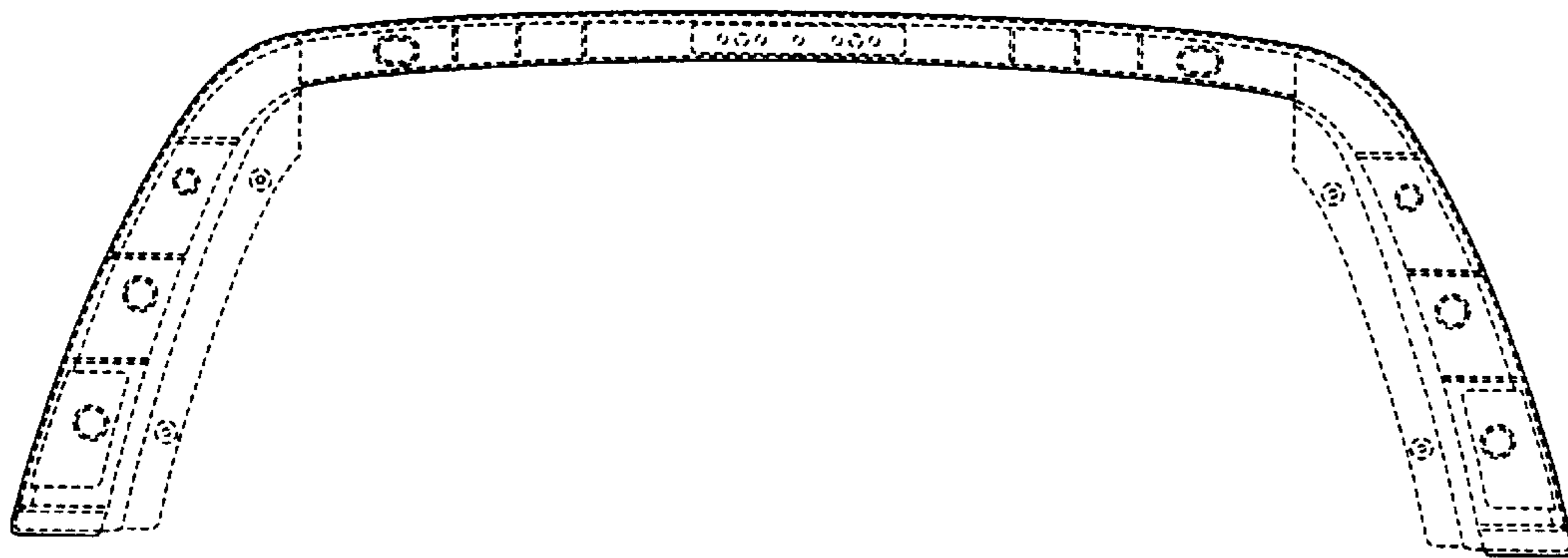

FIG. 3

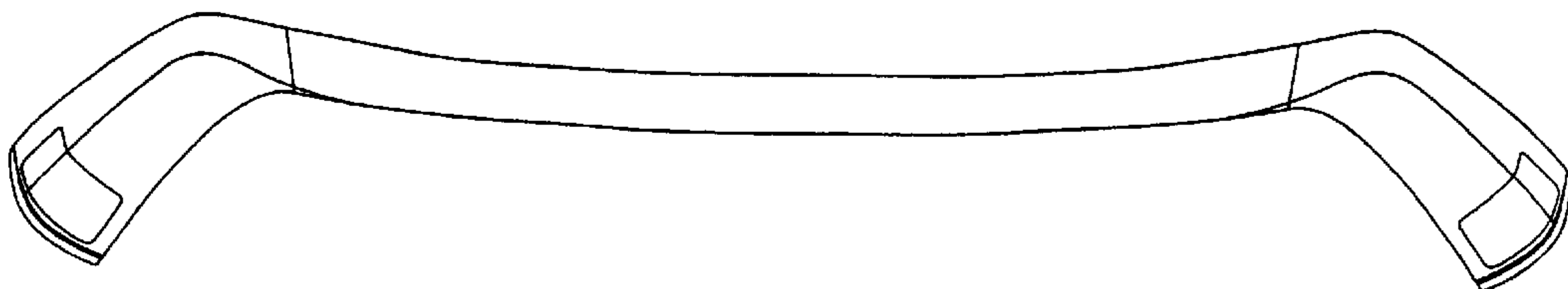

FIG. 4

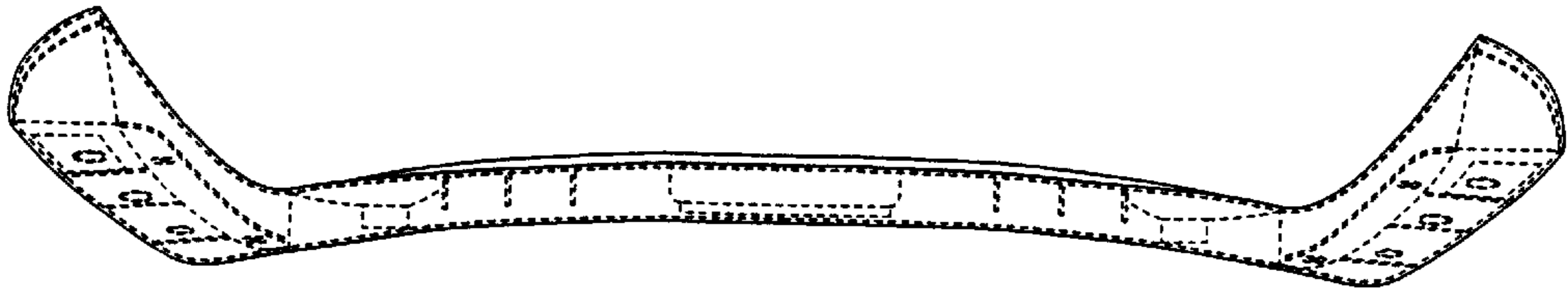

FIG. 5

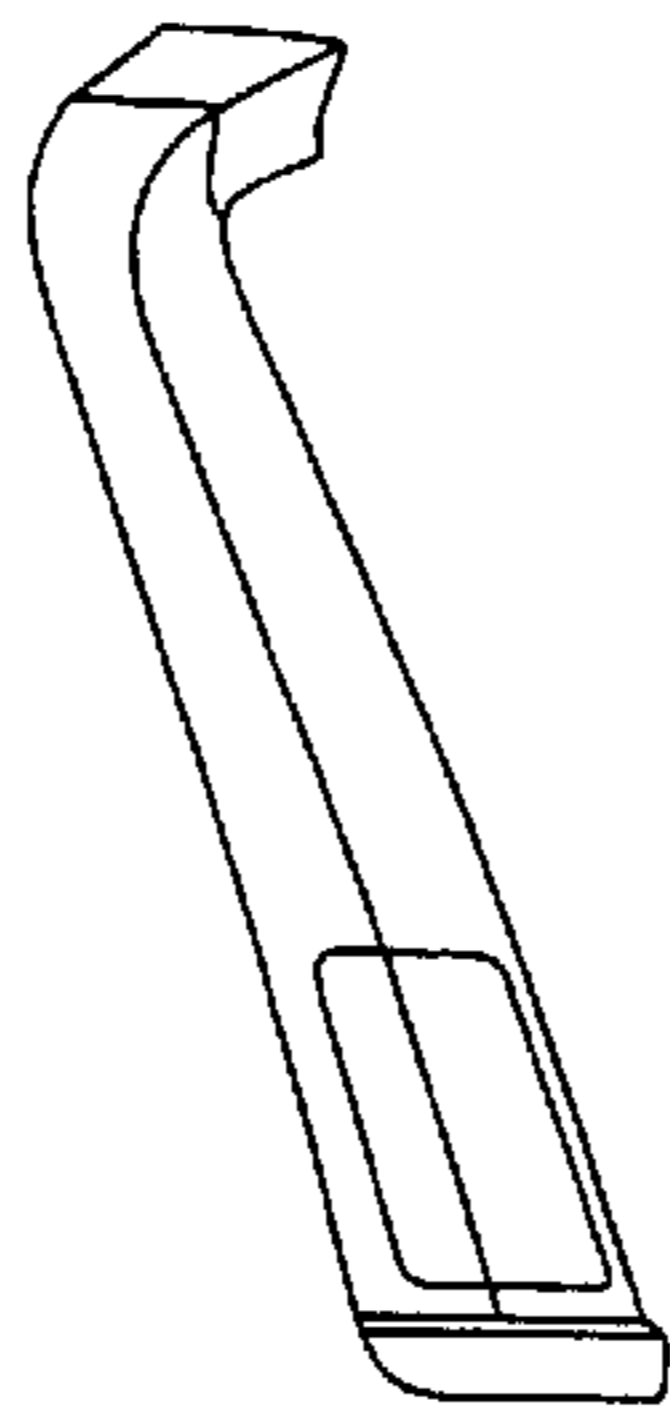

FIG. 6

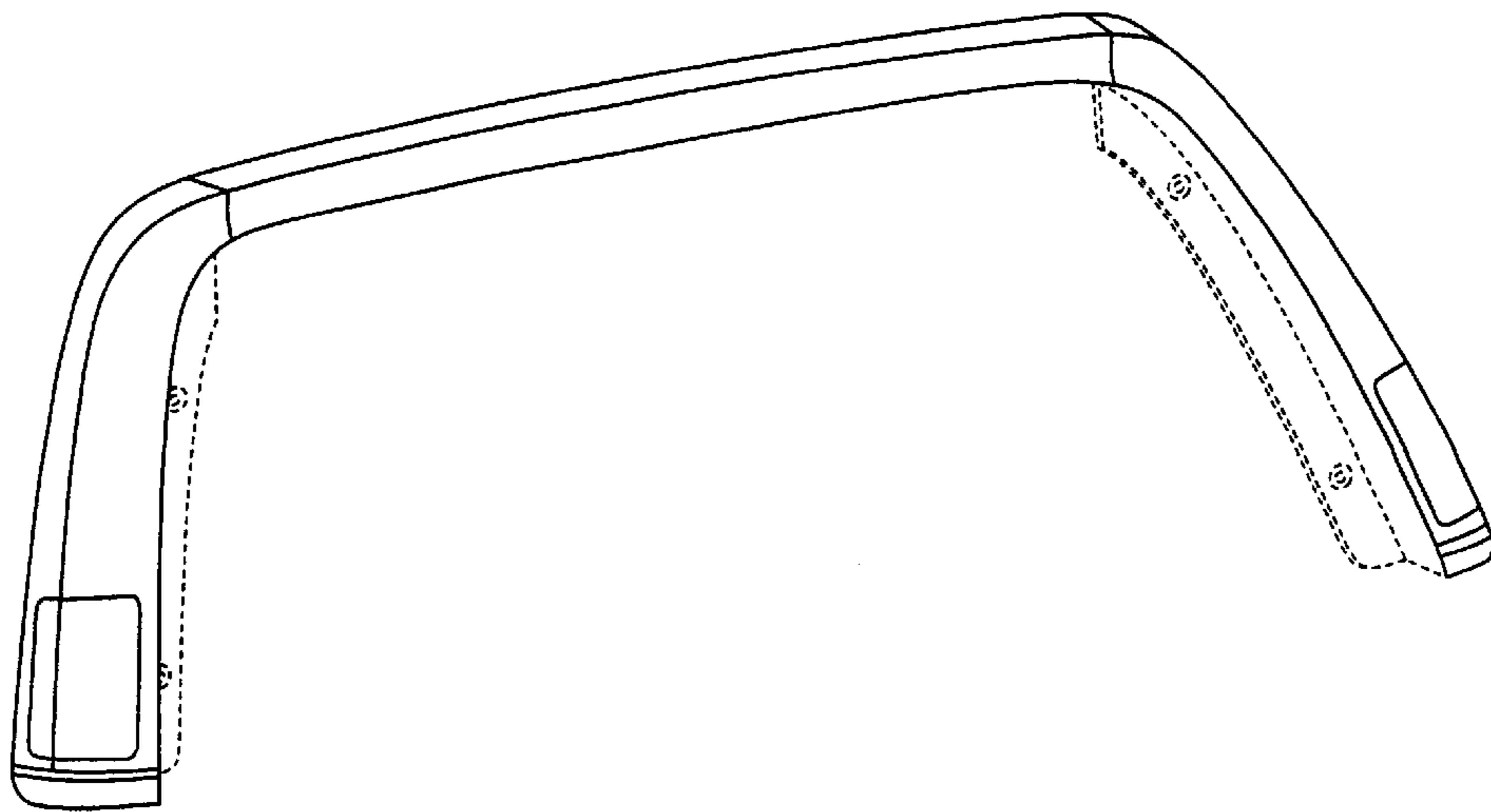

FIG. 7

