



US00D469159S

(12) **United States Design Patent**  
**Marshall**

(10) **Patent No.:** **US D469,159 S**

(45) **Date of Patent:** **\*\* Jan. 21, 2003**

(54) **SANITARY FITTING, ESPECIALLY  
KITCHEN FAUCET**

D442,264 S \* 5/2001 Mullenmeister ..... D23/252  
D447,541 S \* 9/2001 Dretzka ..... D23/243  
D460,534 S \* 7/2002 Hanna et al. .... D23/252

(75) Inventor: **Chris Marshall**, Cumming, GA (US)

**OTHER PUBLICATIONS**

(73) Assignee: **Hansgrohe AG**, Schiltach (DE)

2000 Moen Price Catalog, pp. 40–41, 44–45 (1999).  
Catalog, Bäder 2001, 6 pages (2000).  
Product Portfolio, Price Pfister, 6 pages (1999).

(\*\*) Term: **14 Years**

\* cited by examiner

(21) Appl. No.: **29/158,419**

*Primary Examiner*—Louis S. Zarfes

(22) Filed: **Apr. 4, 2002**

*Assistant Examiner*—Gregory Andoll

(51) **LOC (7) Cl.** ..... **23-01**

(74) *Attorney, Agent, or Firm*—Duane Morris LLP

(52) **U.S. Cl.** ..... **D23/242**

(58) **Field of Search** ..... D23/238–243,  
D23/250–257; 4/675–678; 137/801

(57) **CLAIM**

The ornamental design for a sanitary fitting, especially kitchen faucet, as shown and described.

(56) **References Cited**

**DESCRIPTION**

**U.S. PATENT DOCUMENTS**

D276,259 S	*	11/1984	Miller	.....	D23/241
D373,179 S	*	8/1996	Sieger	.....	D23/241
D384,132 S	*	9/1997	Doughty et al.	.....	D23/241
D392,720 S	*	3/1998	Doughty et al.	.....	D23/250
D404,470 S	*	1/1999	Pitsch et al.	.....	D23/252
D406,323 S	*	3/1999	Snyder	.....	D23/255
D406,876 S	*	3/1999	Ko	.....	D23/241
D409,288 S	*	5/1999	Hyde	.....	D23/250
D418,580 S	*	1/2000	Warshawsky et al.	.....	D23/242
D430,650 S	*	9/2000	Graves	.....	D23/242
D439,954 S	*	4/2001	Spangler	.....	D23/250

FIG. 1: is a side perspective view of a sanitary fitting, especially kitchen faucet showing my new design;  
FIG. 2: is a front elevation view thereof;  
FIG. 3: is a side elevation view thereof, the opposite side being a mirror image;  
FIG. 4: is a rear elevation view thereof;  
FIG. 5: is a top plan view thereof; and,  
FIG. 6: is a bottom plan view thereof.

**1 Claim, 6 Drawing Sheets**

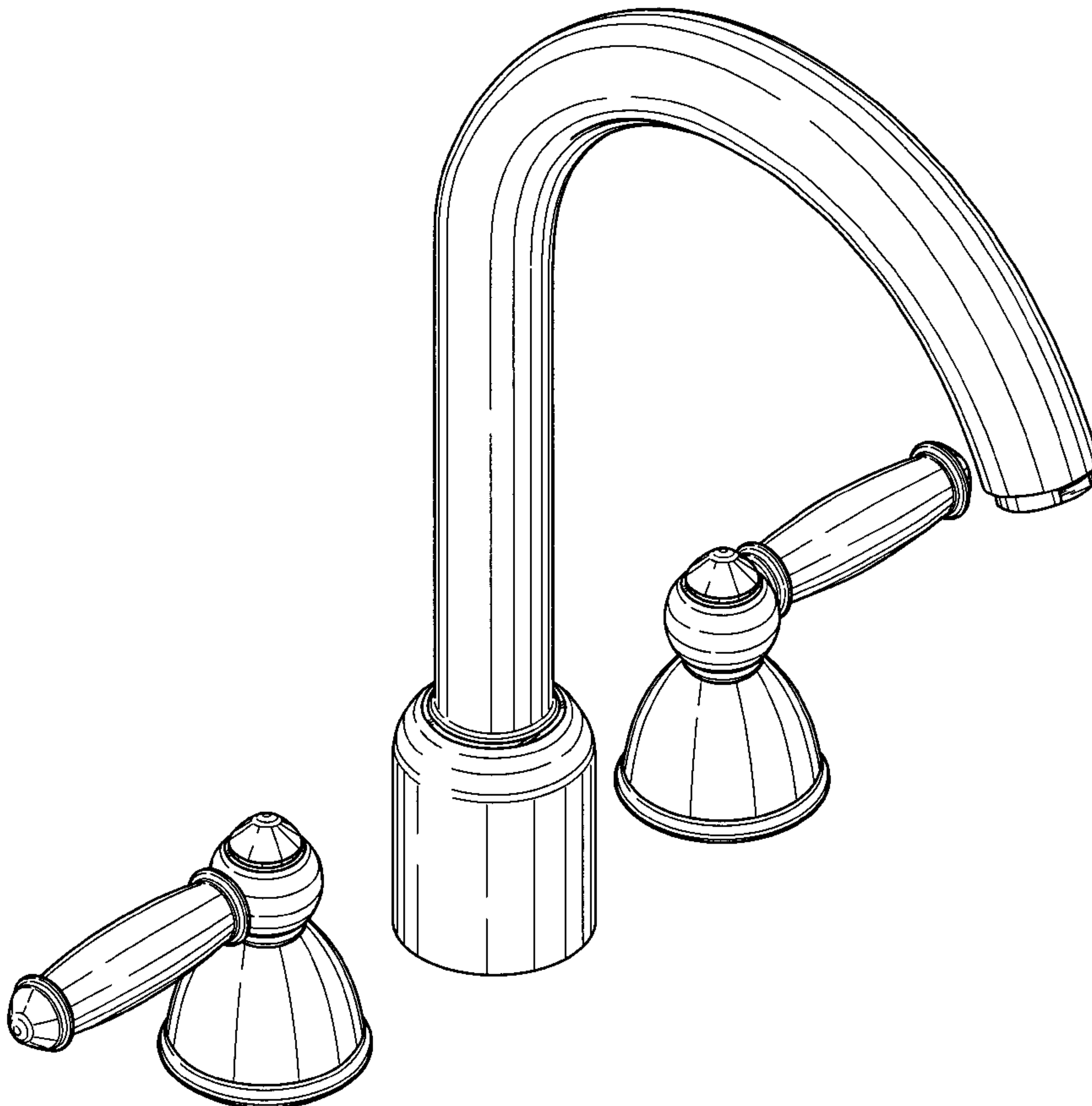

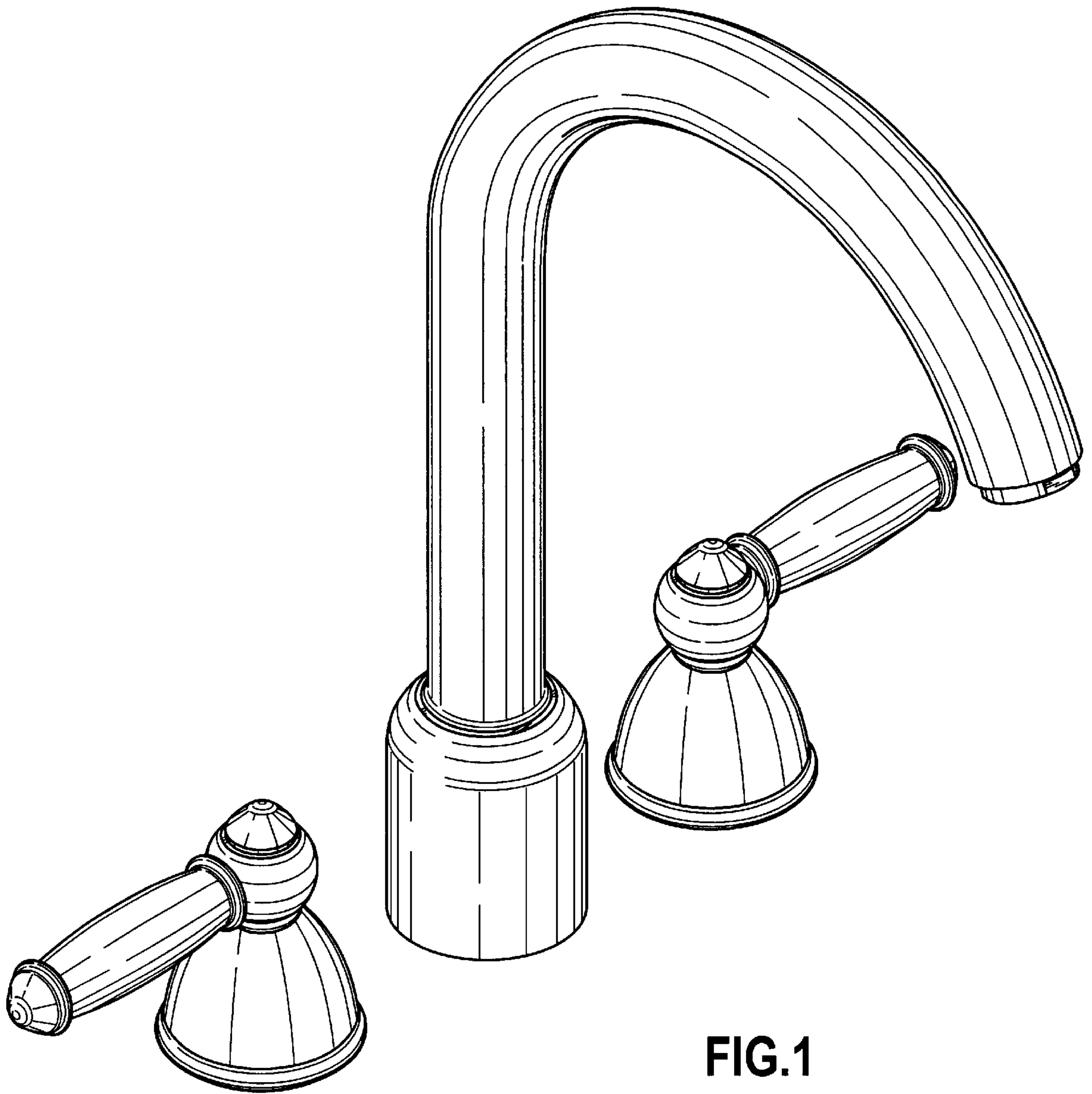

FIG.1

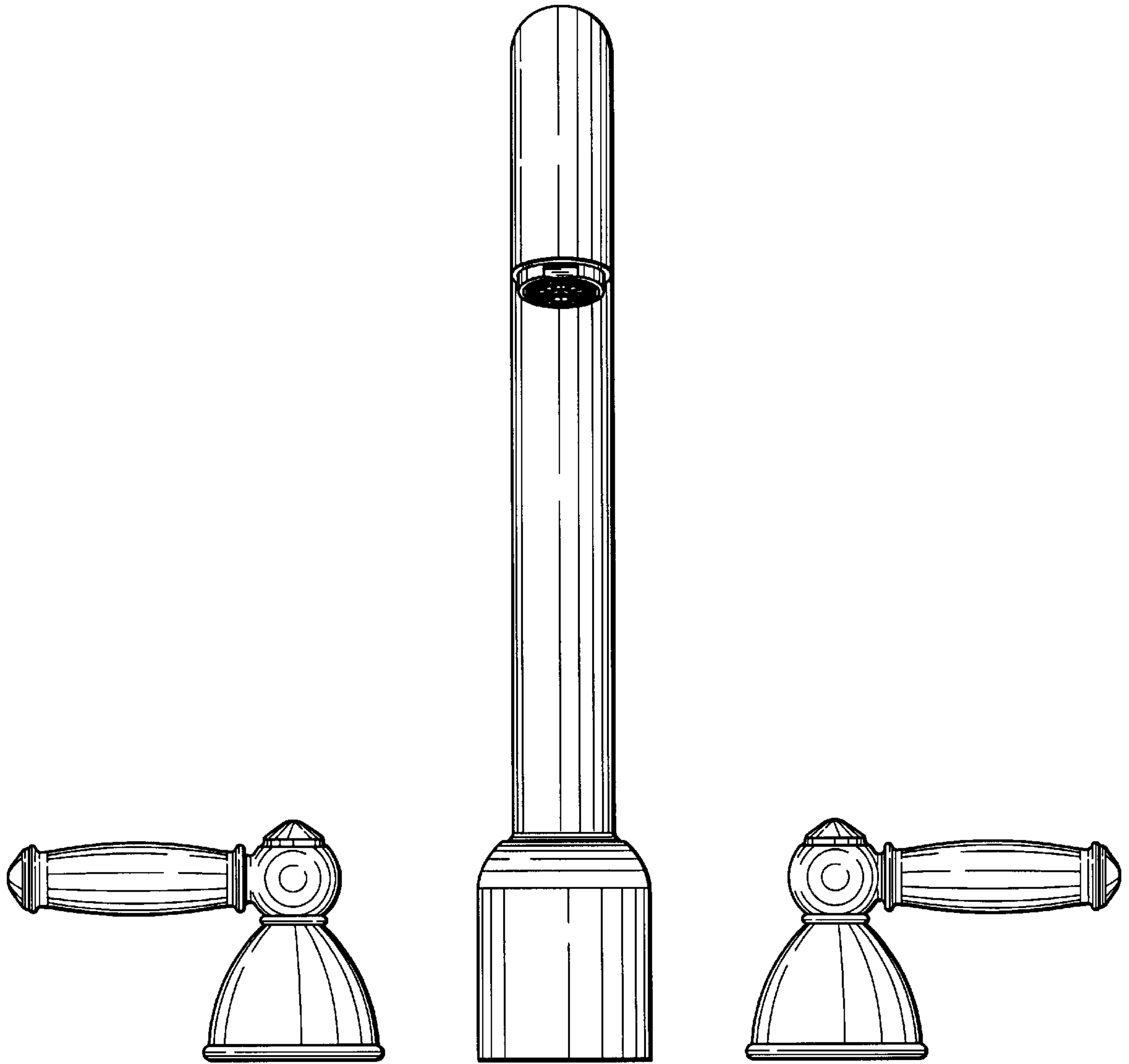
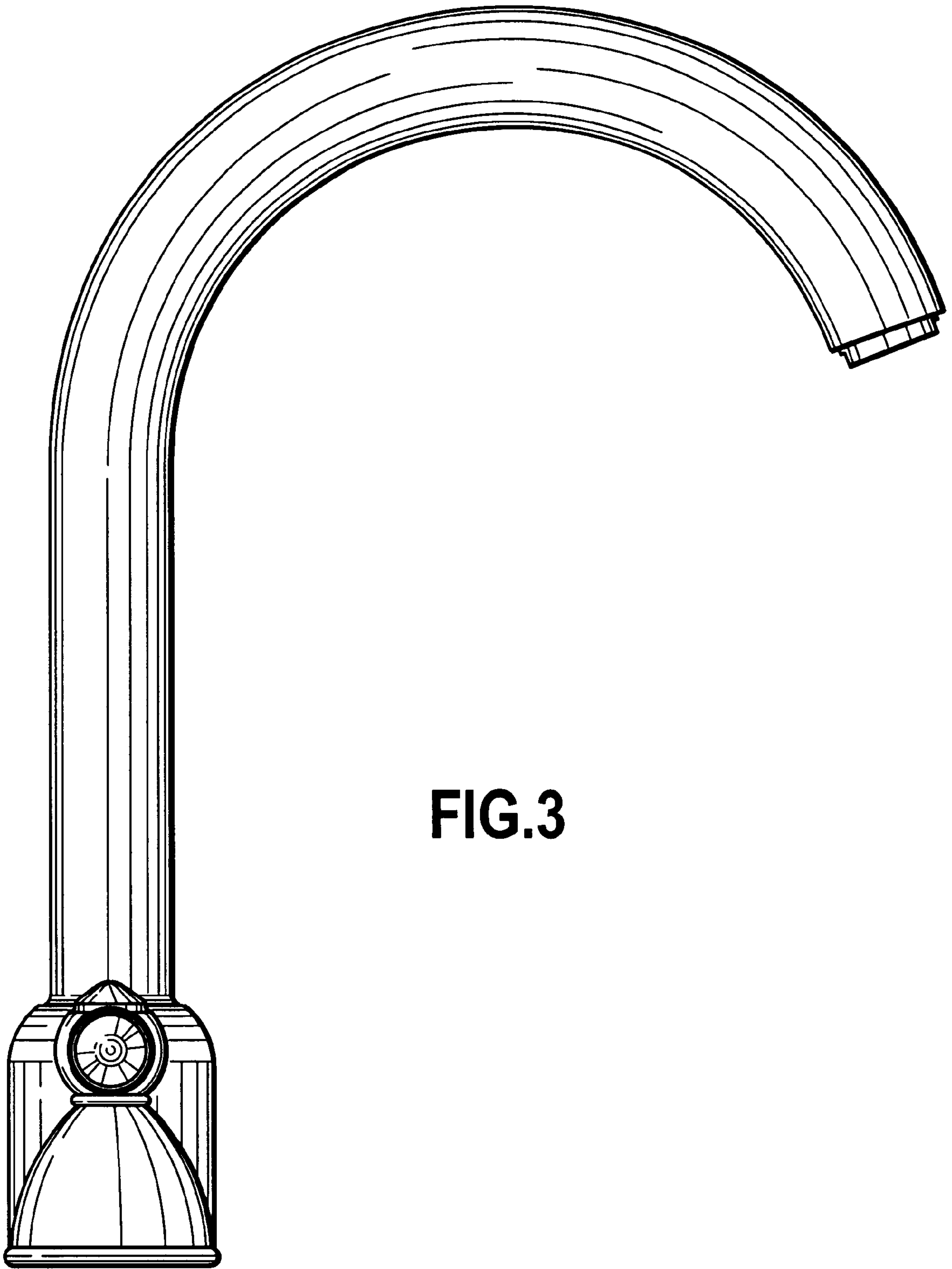

FIG.2



**FIG.3**

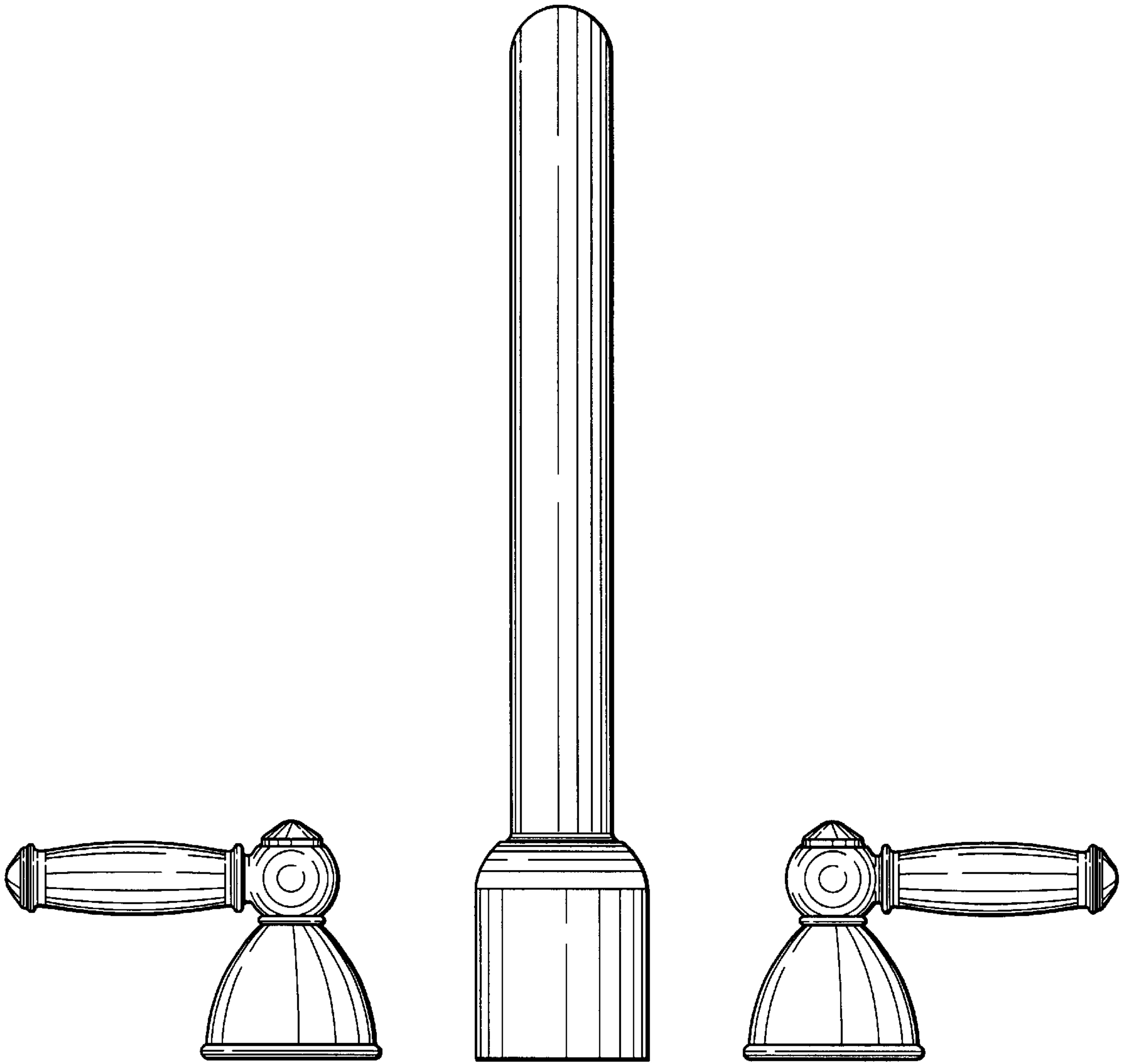
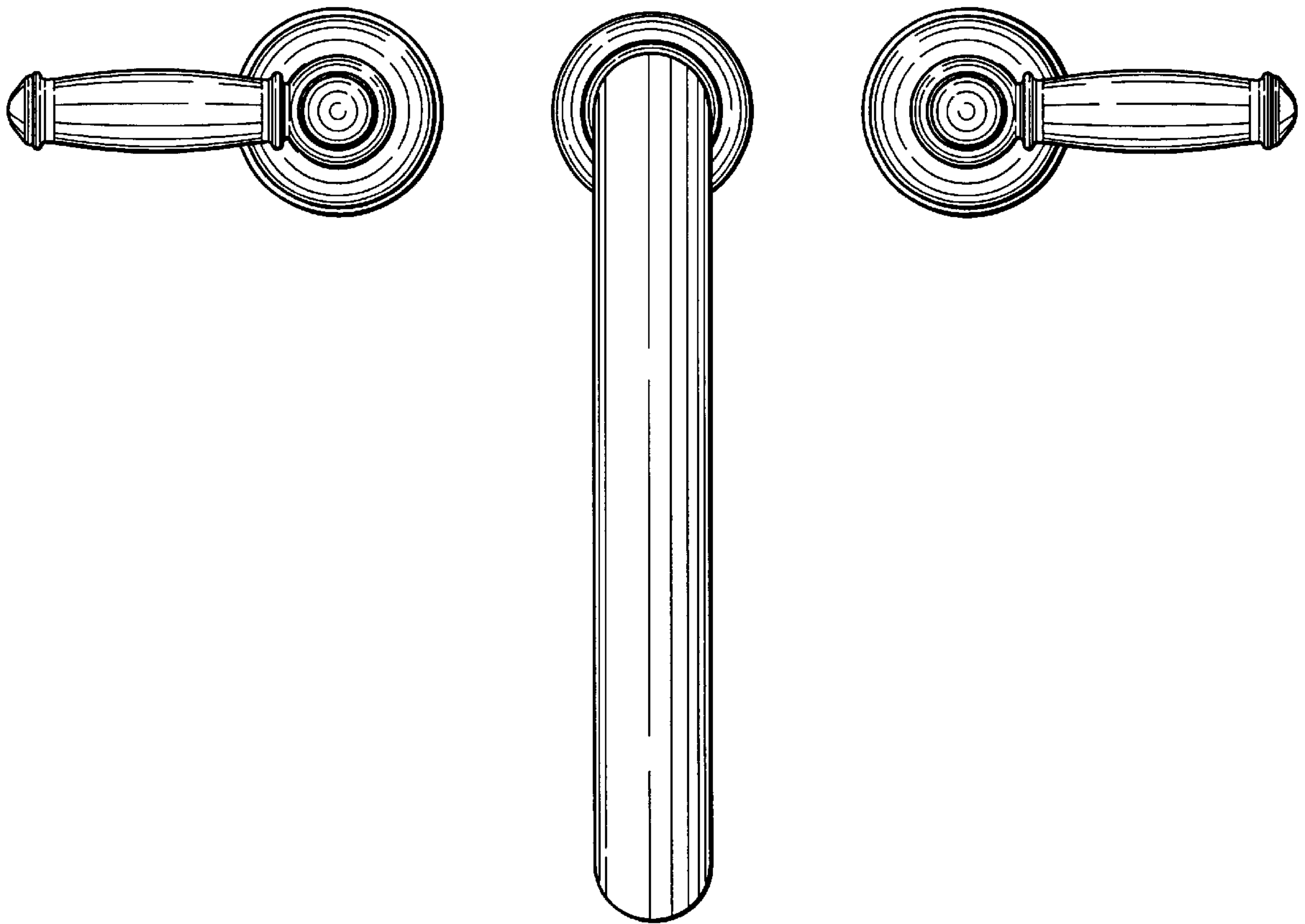

FIG.4

FIG.5





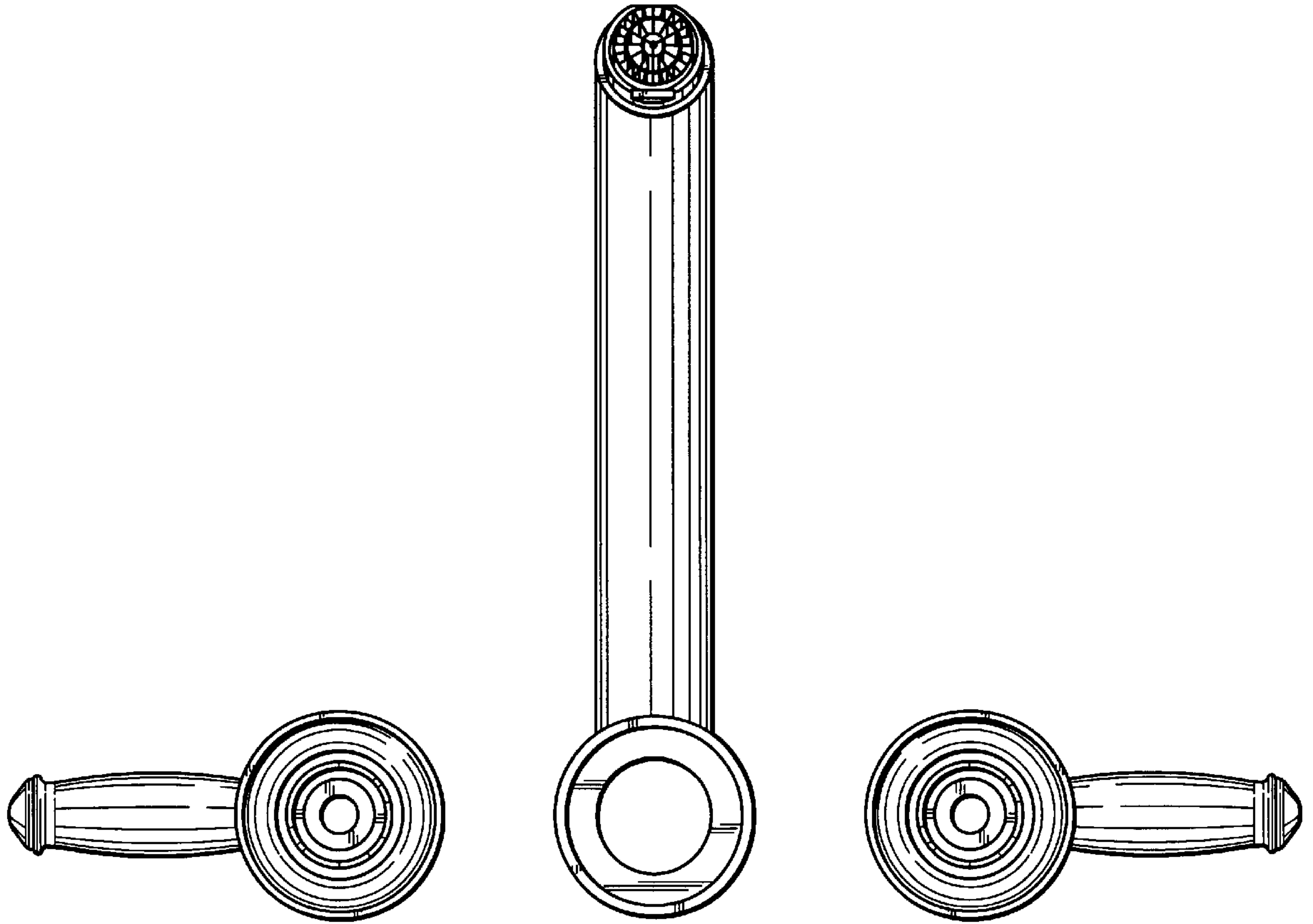

FIG. 6