



US00D468902S

(12) **United States Design Patent**
Willows et al.

(10) **Patent No.:** **US D468,902 S**

(45) **Date of Patent:** **** Jan. 21, 2003**

(54) **BOTTLE PACK**

(76) Inventors: **Keith Willows**, 1823 12th Ave. W.,
Seattle, WA (US) 98119; **June Angus**,
1823 12th Ave. W., Seattle, WA (US)
98119

(**) Term: **14 Years**

(21) Appl. No.: **29/157,419**

(22) Filed: **Mar. 18, 2002**

(51) **LOC (7) Cl.** **03-01**

(52) **U.S. Cl.** **D3/226**

(58) **Field of Search** D3/226, 224, 215,
D3/230, 232, 233; 224/904, 901, 240, 241,
245, 269, 684

(56) **References Cited**

U.S. PATENT DOCUMENTS

5,577,653 A * 11/1996 Bieker 224/684

D406,455 S * 3/1999 Wagner, II D3/226

D448,925 S * 10/2001 Willows et al. D3/226

D458,021 S * 6/2002 Willows et al. D3/226

* cited by examiner

Primary Examiner—Catherine R. Oliver

(57) **CLAIM**

The ornamental design for a “bottle pack”, as shown.

DESCRIPTION

FIG. 1 is a front view of a bottle pack;

FIG. 2 is a top plan view thereof;

FIG. 3 is a rear view of FIG. 1;

FIG. 4 is a bottom plan view of FIG. 1;

FIG. 5 is a right—side view of FIG. 1; and,

FIG. 6 is a left—side view of FIG. 1.

The broken line showing of buckles and bottle in FIGS. 1 through 6 is for illustrative purposes only and forms no part of the claimed design.

1 Claim, 3 Drawing Sheets

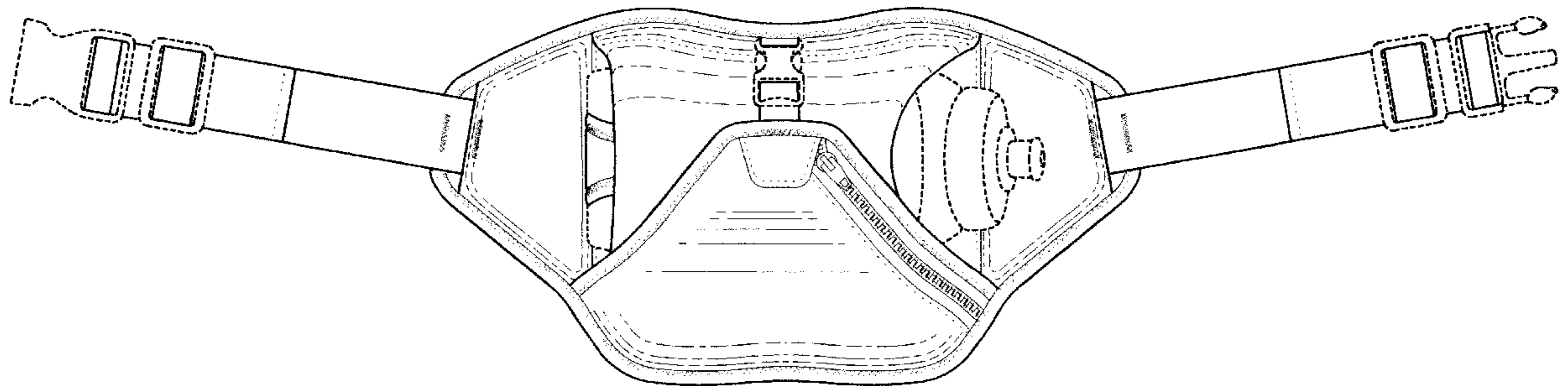

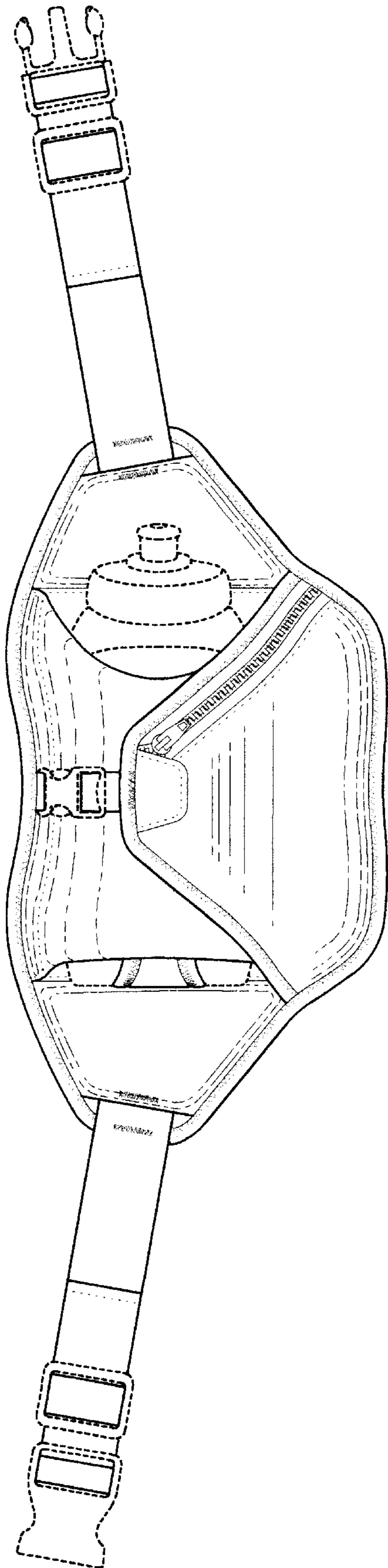

FIG. 1

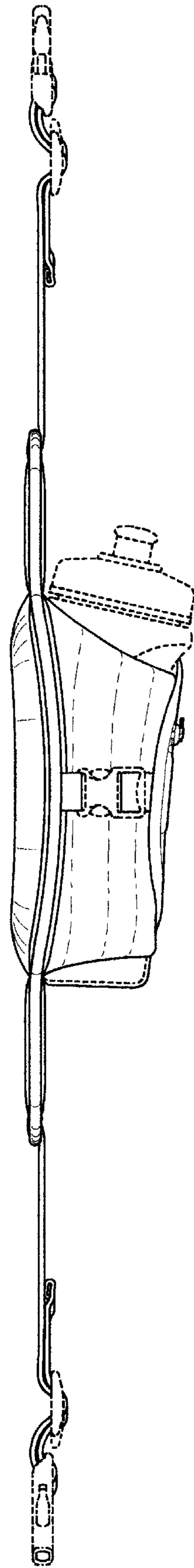

FIG. 2

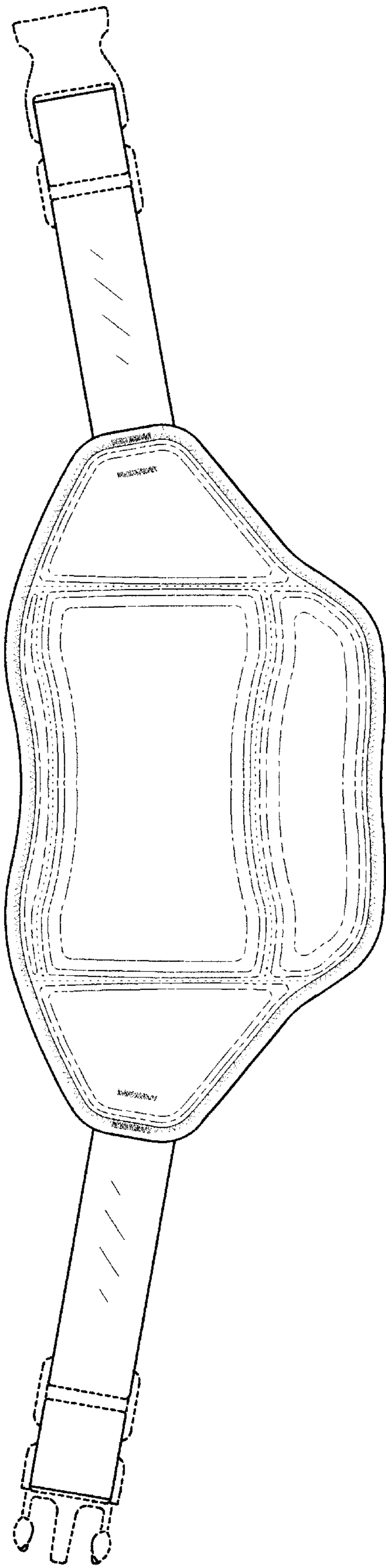

FIG. 3

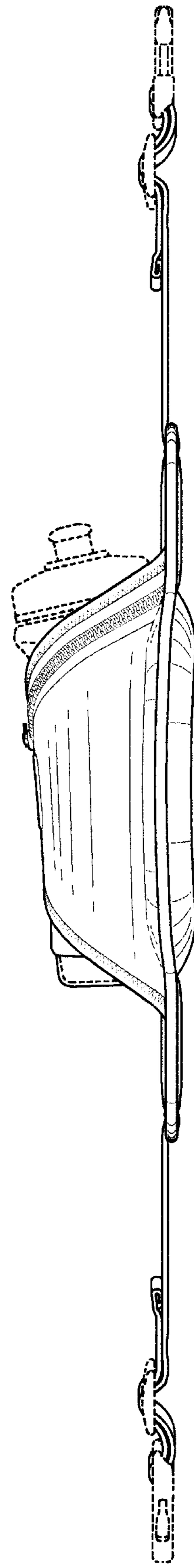

FIG. 4

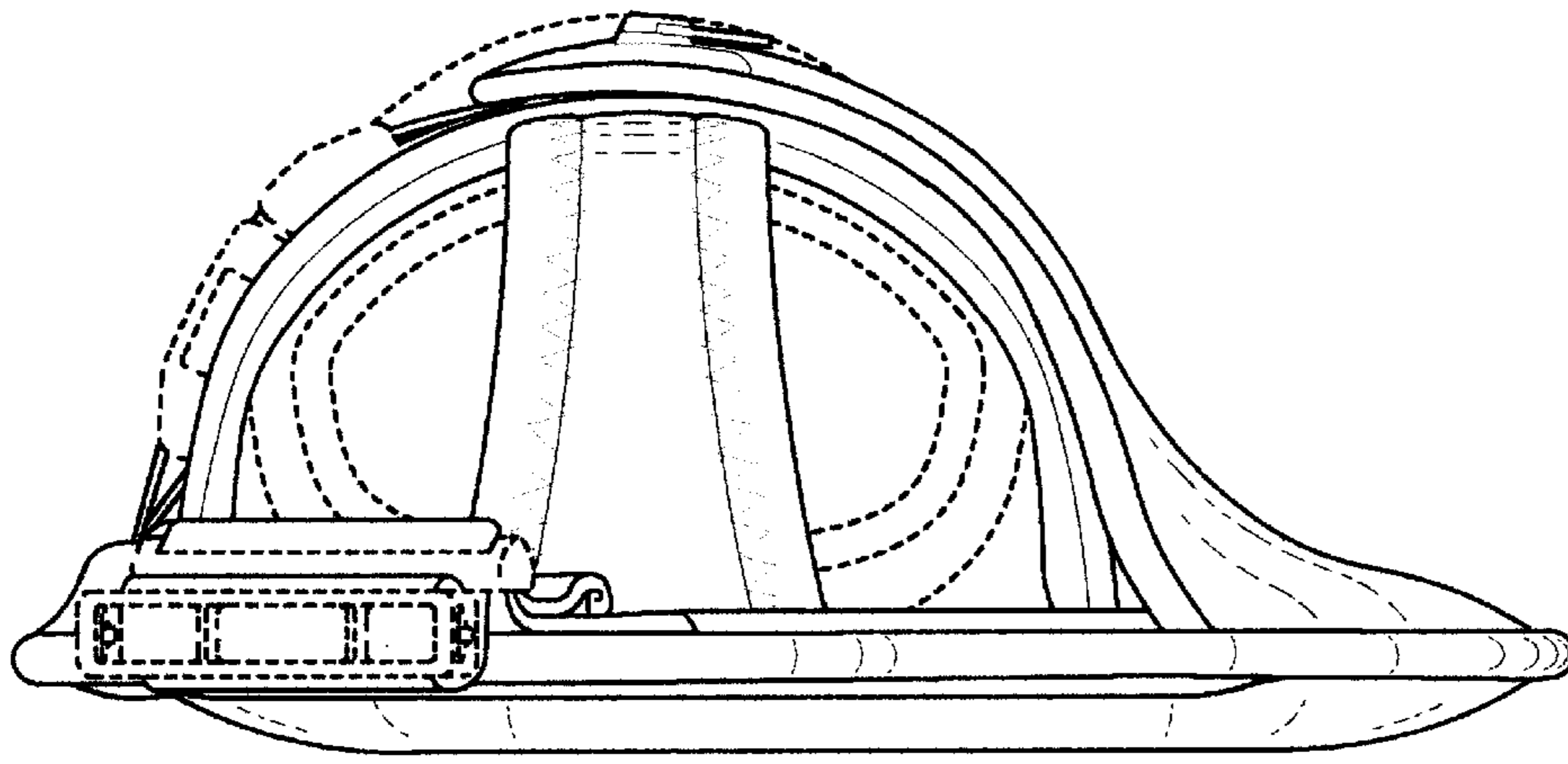

FIG. 6

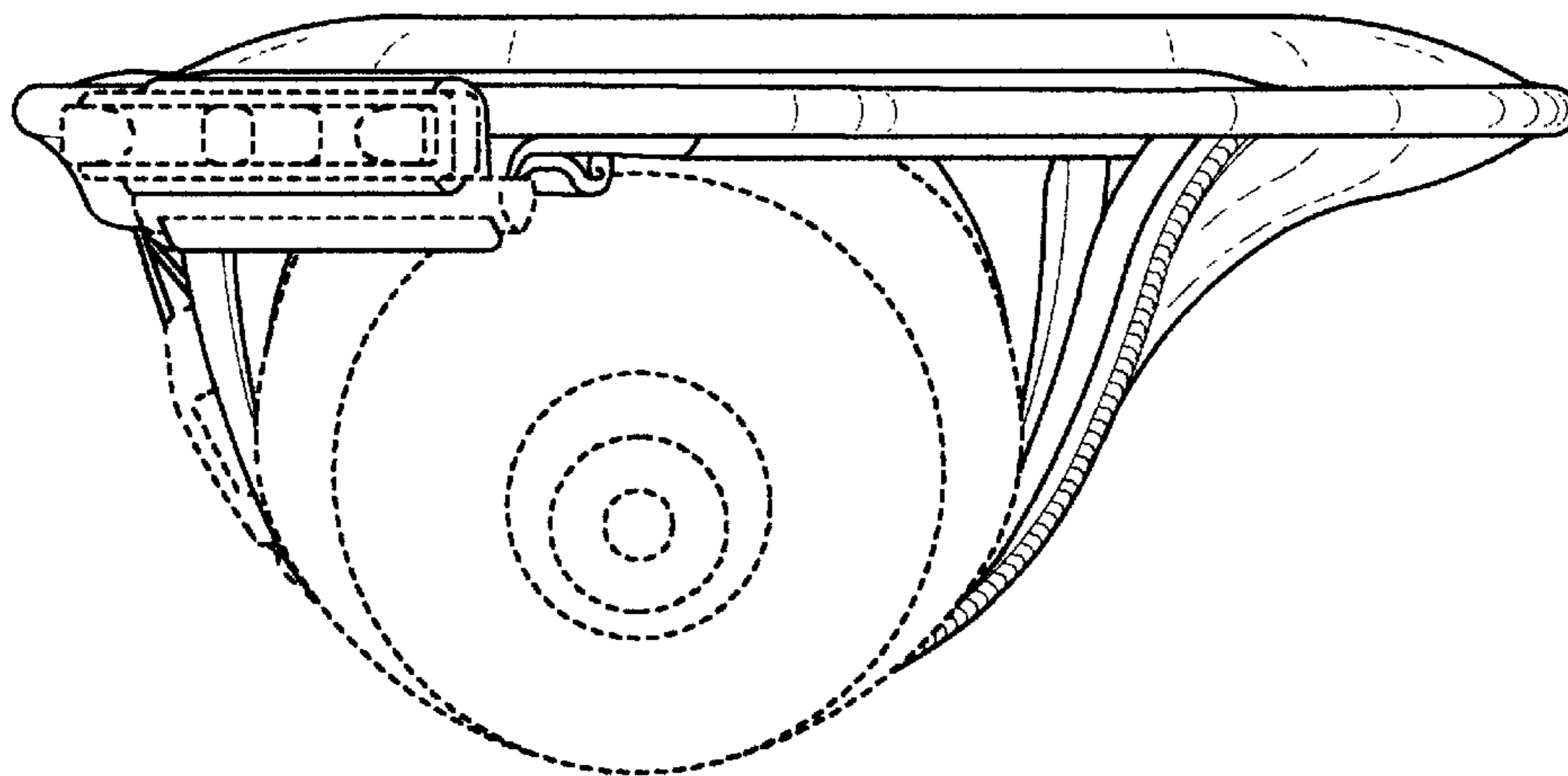

FIG. 5