



US00D46885S

(12) **United States Design Patent**  
**Salin et al.**

(10) **Patent No.: US D468,885 S**

(45) **Date of Patent: \*\* Jan. 14, 2003**

(54) **FORK LIFT TRUCK**

(75) Inventors: **Sergio Salin, Milan (IT); Ulrich Jochem, Rho (IT)**

(73) Assignee: **Fiat Om Carelli Elevatori S.p.A. (IT)**

(\*\*) Term: **14 Years**

(21) Appl. No.: **29/133,708**

(22) Filed: **Dec. 5, 2000**

(30) **Foreign Application Priority Data**

Jun. 6, 2000 (DE) ..... 4 00 05 594

(51) **LOC (7) Cl. .... 12-05**

(52) **U.S. Cl. .... D34/34**

(58) **Field of Search** ..... D34/28, 35, 34;  
414/529, 572, 607, 785; 180/89.12, 89.14,  
89.17

(56) **References Cited**

**U.S. PATENT DOCUMENTS**

D231,340 S	*	4/1974	Haynes	.....	D34/34
D234,050 S	*	1/1975	Crawford	.....	D34/34
D257,432 S	*	10/1980	Erlacher	.....	D34/34
4,392,669 A	*	7/1983	Martin, Jr.	.....	180/89.12
D281,199 S	*	10/1985	Prawl	.....	D34/28
4,688,981 A	*	8/1987	Ravnsborg et al.	.....	414/572
D327,356 S	*	6/1992	Laatsch	.....	D34/34
5,184,699 A	*	2/1993	Aoki et al.	.....	414/631
D338,764 S	*	8/1993	Furuta et al.	.....	D34/34
5,238,086 A	*	8/1993	Aoki et al.	.....	414/631
D361,645 S	*	8/1995	Heiler	.....	D34/34
D362,329 S	*	9/1995	Heiler	.....	D34/34
D367,750 S	*	3/1996	Choi et al.	.....	D34/34
D371,669 S	*	7/1996	Yoon	.....	D34/34
D374,752 S	*	10/1996	Lee et al.	.....	D34/34
D376,242 S	*	12/1996	Jung et al.	.....	D34/34
D384,476 S	*	9/1997	Rick et al.	.....	D34/34
D386,872 S	*	11/1997	Rick et al.	.....	D34/34
D386,875 S	*	11/1997	Kim	.....	D34/34
D386,877 S	*	11/1997	Russey et al.	.....	D34/34
D389,981 S	*	1/1998	Donaldson	.....	D34/34
D389,982 S	*	1/1998	Kim	.....	D34/34
D393,134 S	*	3/1998	Mariano	.....	D34/34
D393,516 S	*	4/1998	Hahn et al.	.....	D34/34

D393,517 S	*	4/1998	Kim et al.	.....	D34/34
D395,115 S	*	6/1998	Russey et al.	.....	D34/34
D395,532 S	*	6/1998	Kim	.....	D34/34
D396,928 S	*	8/1998	Hahn et al.	.....	D34/34
5,881,842 A	*	3/1999	Kikukawa	.....	187/222
D411,681 S	*	6/1999	Murakami et al.	.....	D34/34
D412,385 S	*	7/1999	Murakami et al.	.....	D34/34
D427,409 S	*	6/2000	Sato et al.	.....	D34/34
6,092,976 A	*	7/2000	Kamiya	.....	414/631
D432,753 S	*	10/2000	Braud	.....	D34/34
D441,936 S	*	5/2001	Brandt et al.	.....	D34/28
6,233,827 B1	*	5/2001	Oliver et al.	.....	187/222
D444,607 S	*	7/2001	Yurushi et al.	.....	D34/34
D448,136 S	*	9/2001	Yurushi et al.	.....	D34/34
D452,598 S	*	12/2001	Sato	.....	D34/34

\* cited by examiner

*Primary Examiner*—Cynthia E. Ramirez

(74) *Attorney, Agent, or Firm*—Webb Ziesenheim Logsdon Orkin & Hanson, P.C.

(57) **CLAIM**

The ornamental design for a fork lift truck, as shown.

**DESCRIPTION**

FIG. 1 is a perspective view taken from the left front of a first embodiment of a fork lift truck showing our new design; FIG. 2 is a perspective view taken from the right rear of the fork lift truck of FIG. 1;

FIG. 3 is a top plan view thereof; FIG. 4 is a bottom plan view thereof; FIG. 5 is a front elevational view thereof; FIG. 6 is a rear elevational view thereof; FIG. 7 is a right side elevational view thereof; FIG. 8 is a left side elevational view thereof; FIG. 9 is a perspective view taken from the left front of a second embodiment of the forklift truck showing our new design;

FIG. 10 is a top plan view thereof; FIG. 11 is a bottom plan view thereof; FIG. 12 is a front elevational view thereof; FIG. 13 is a rear elevational view thereof; FIG. 14 is a right side elevational view thereof; and, FIG. 15 is a left side elevational view thereof.

**1 Claim, 15 Drawing Sheets**

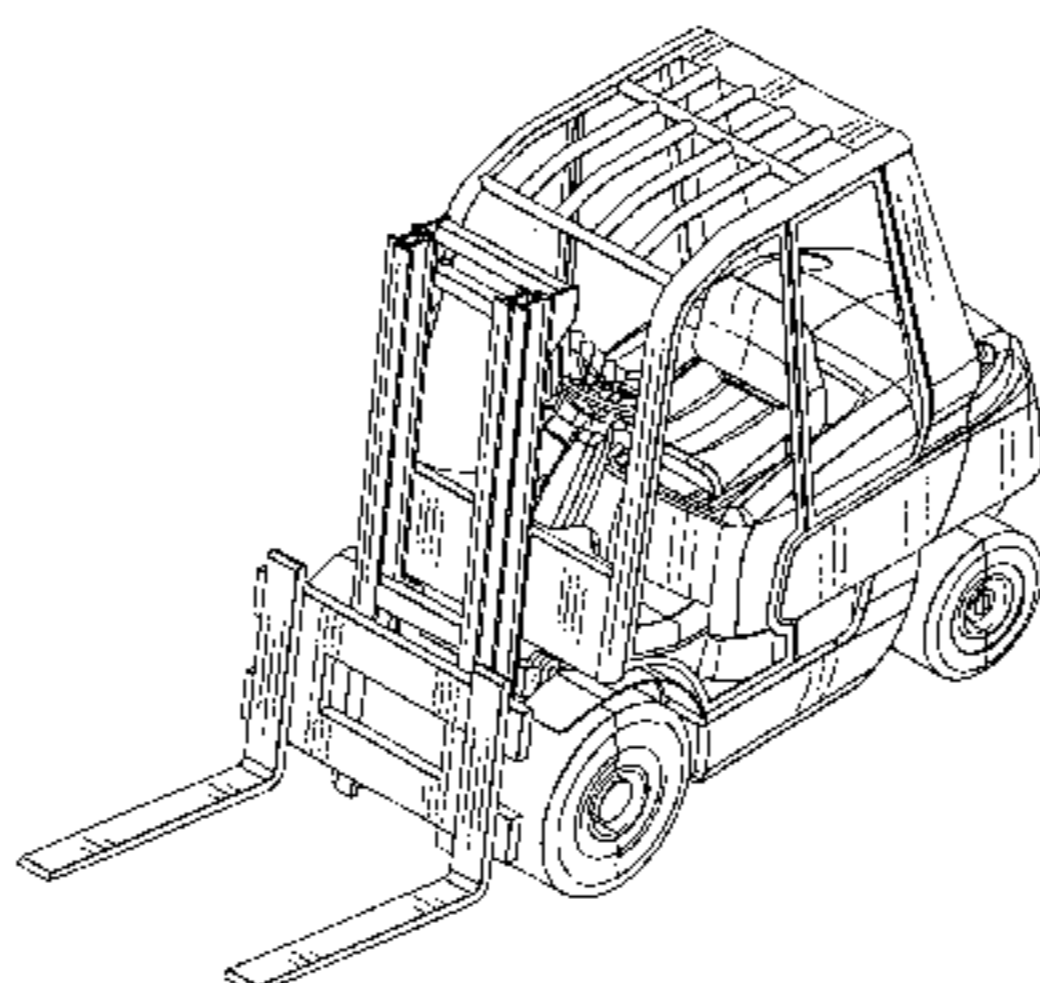
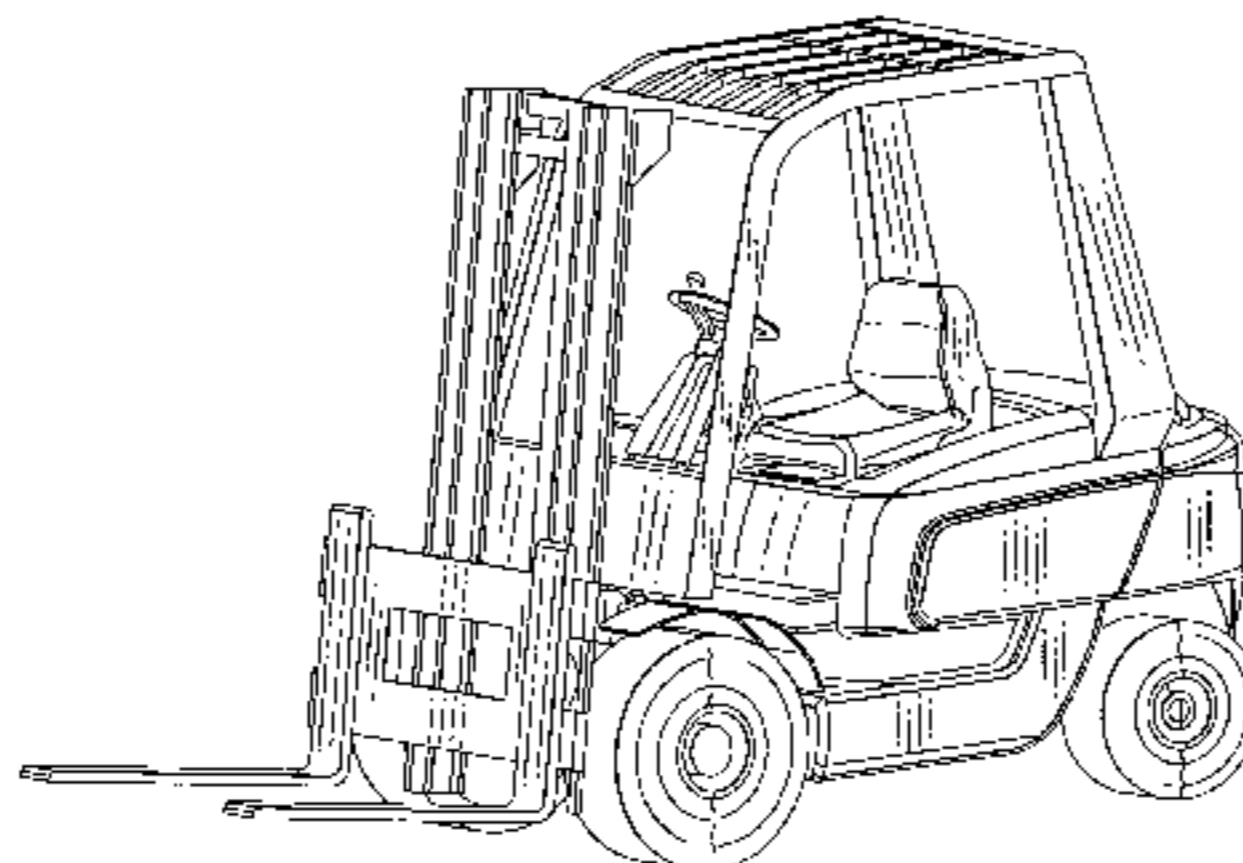

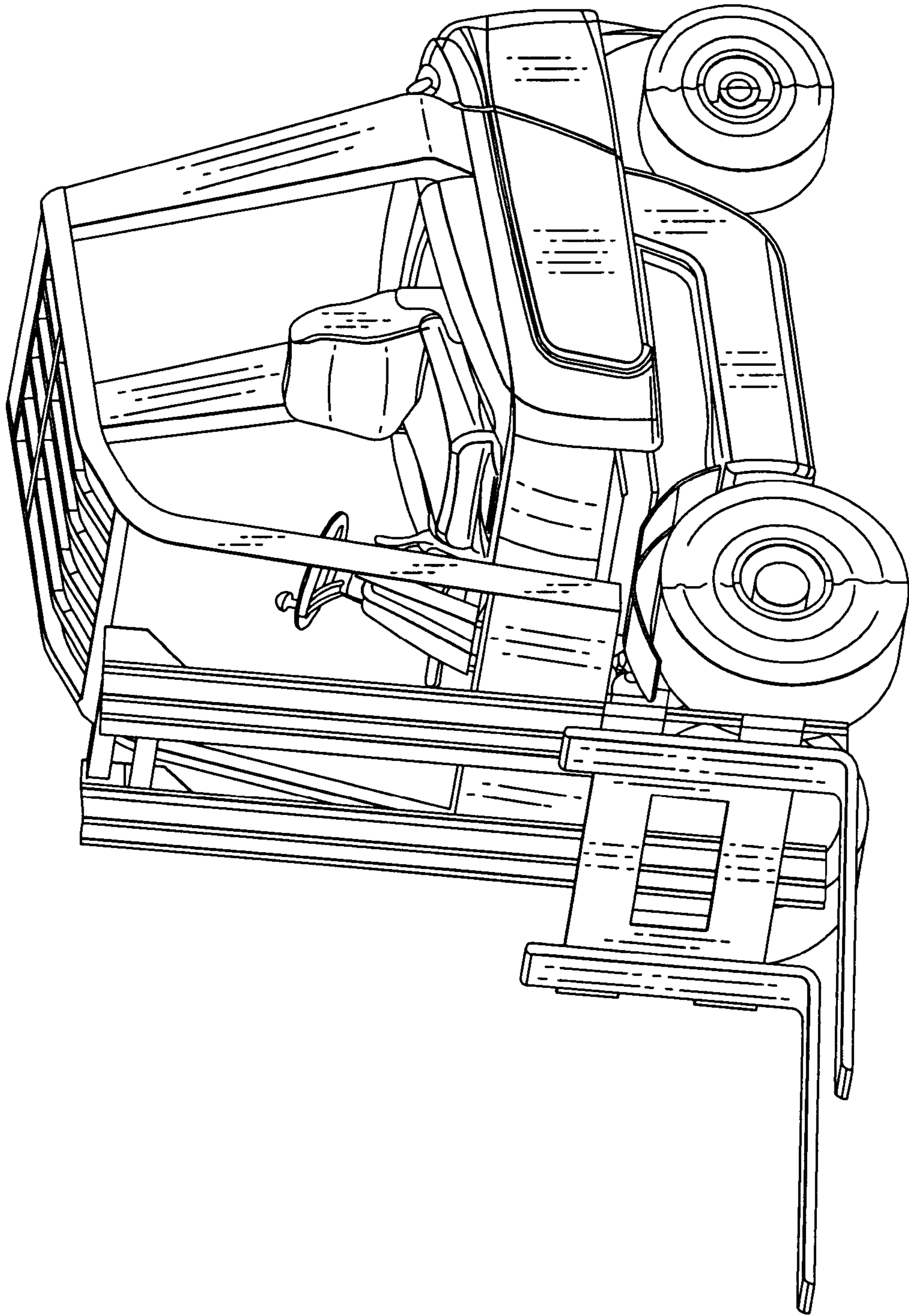

FIG. 1



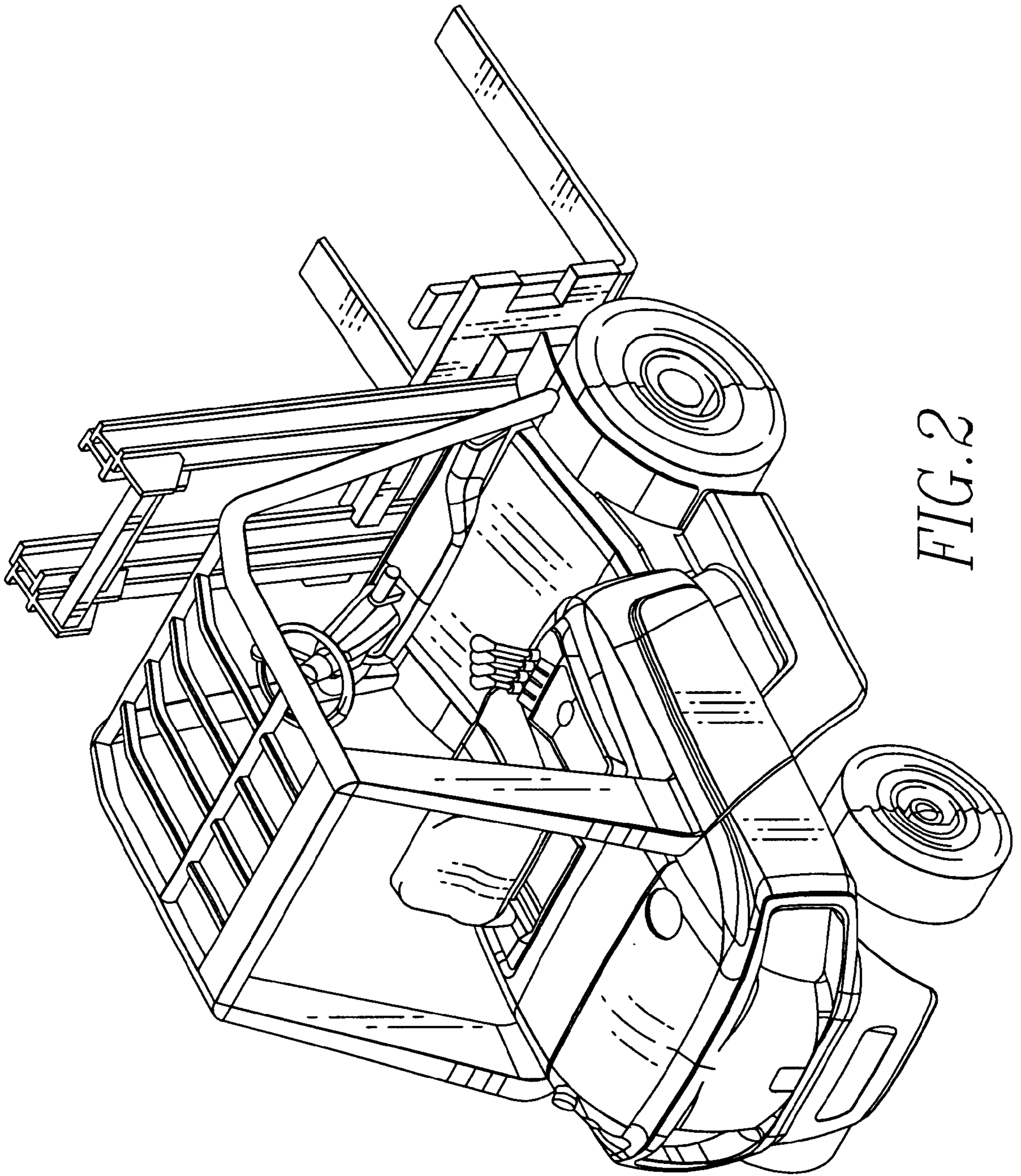

FIG. 2

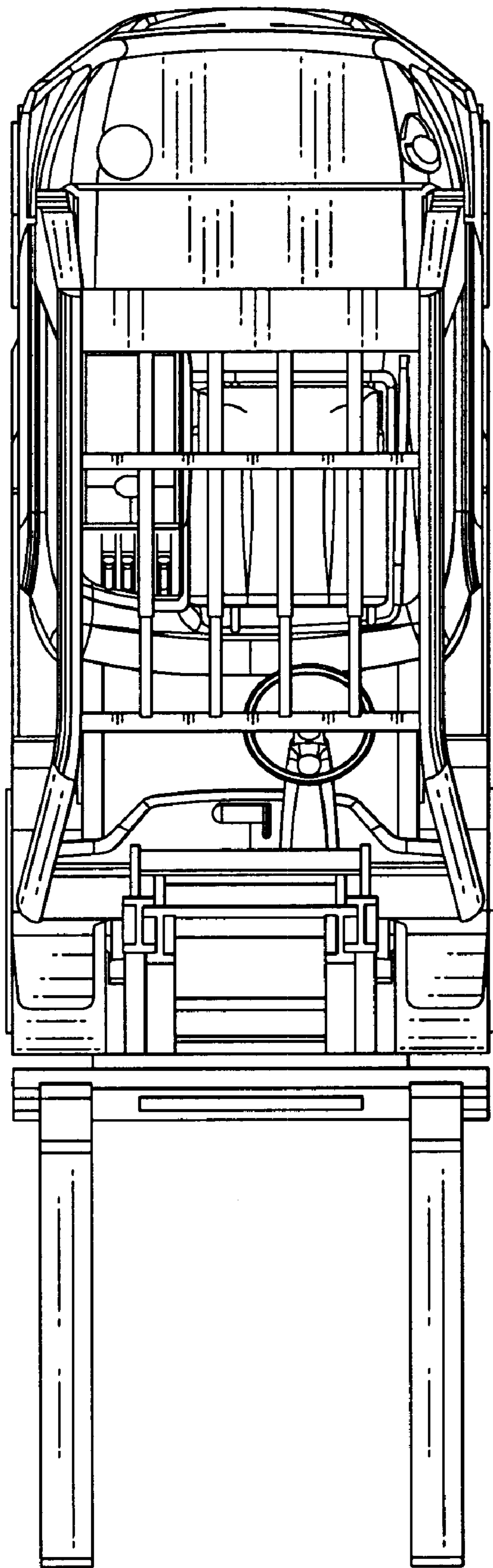

FIG. 3

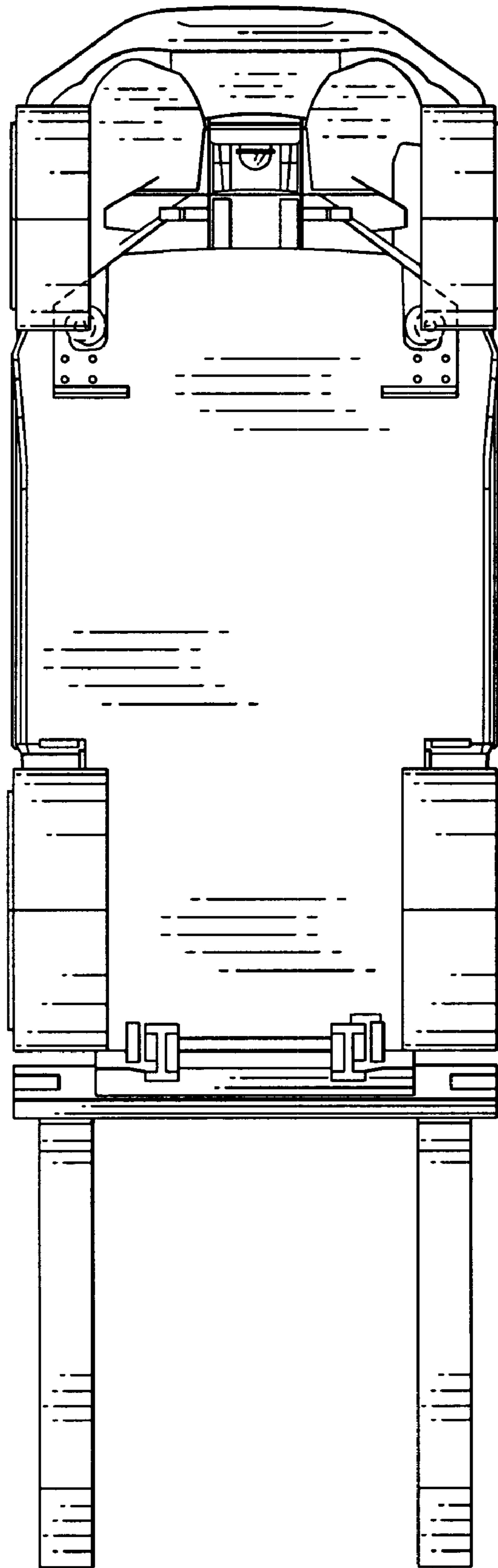
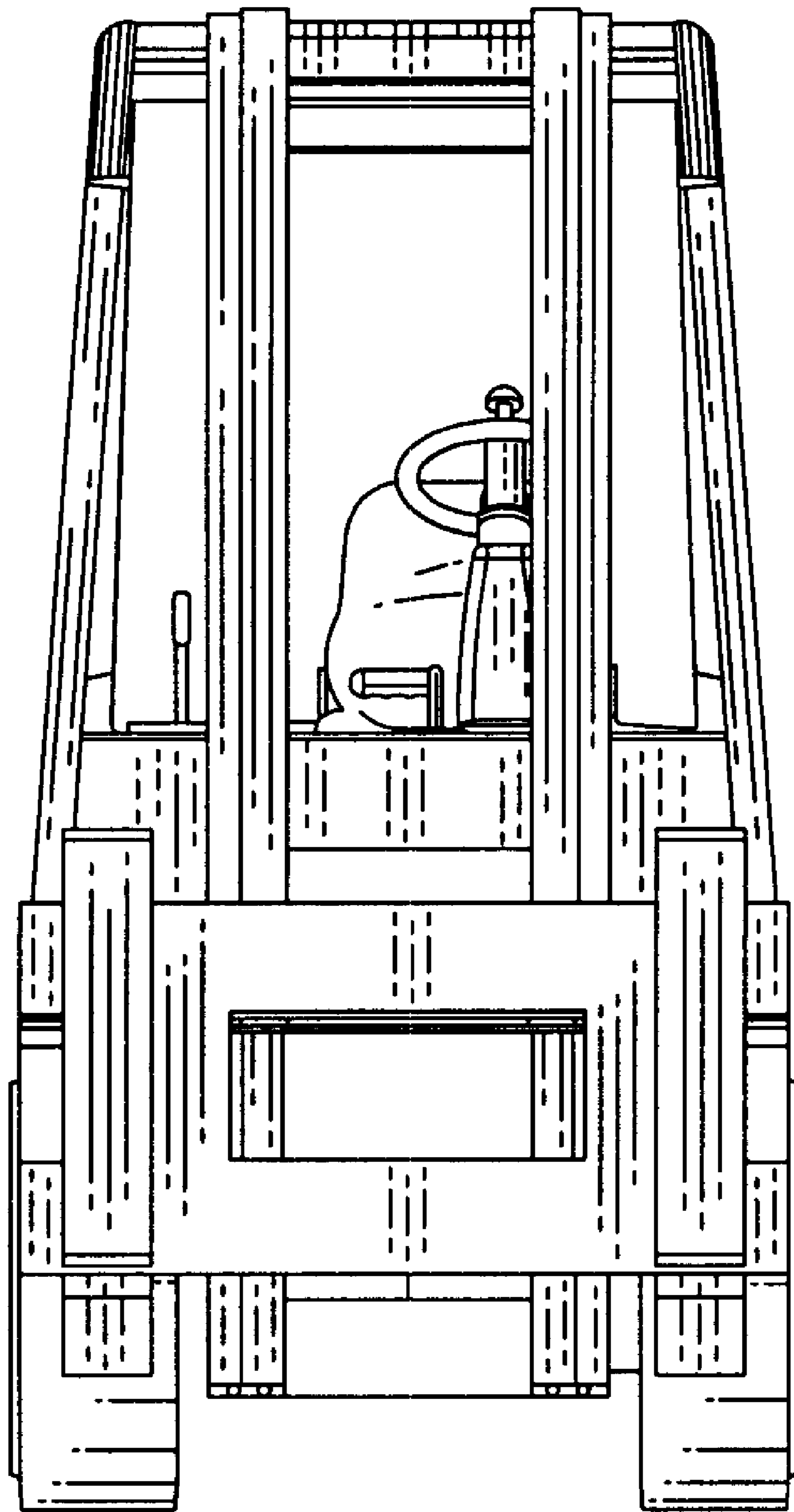
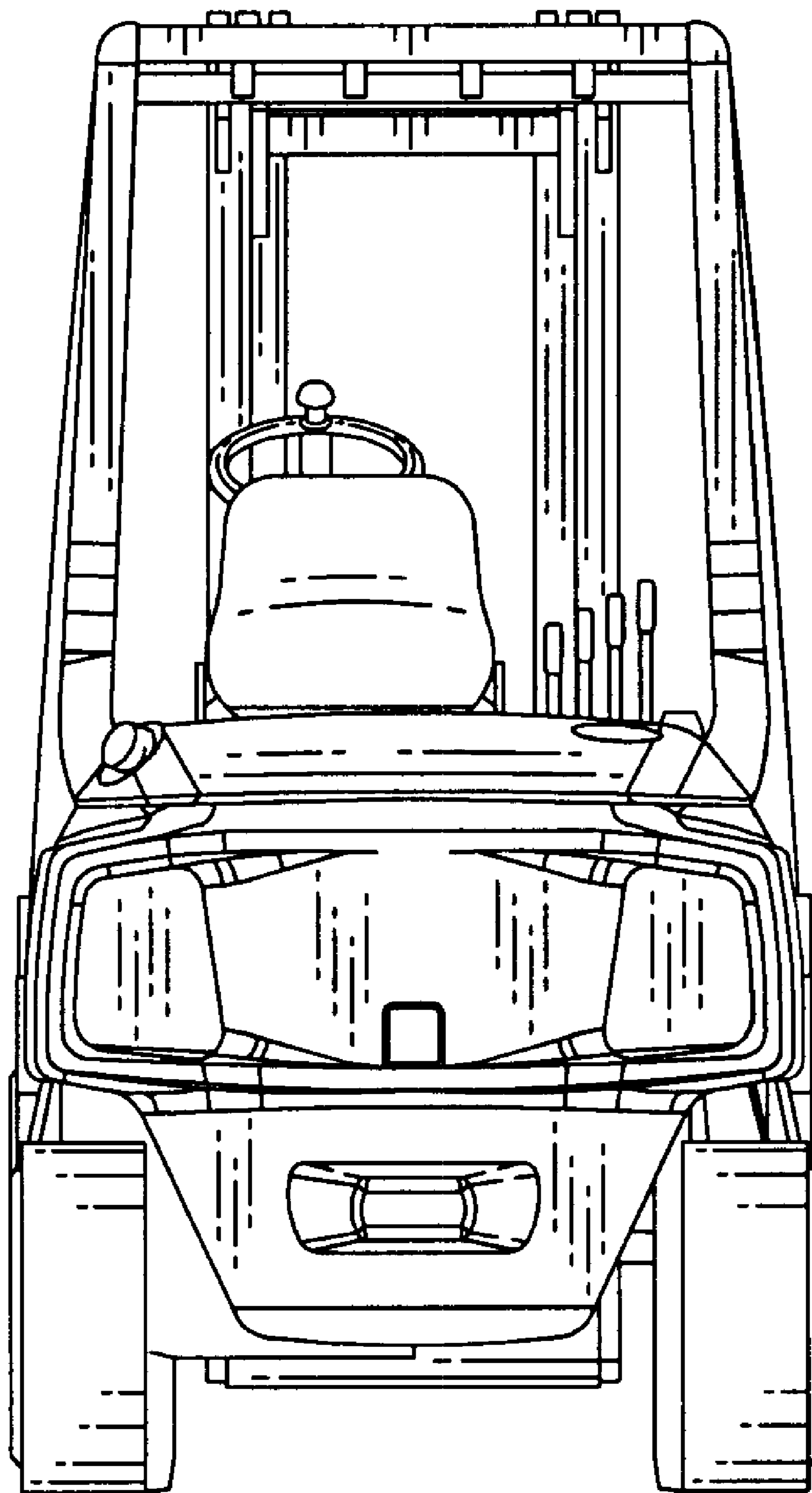

FIG. 4



*FIG. 5*



*FIG. 6*

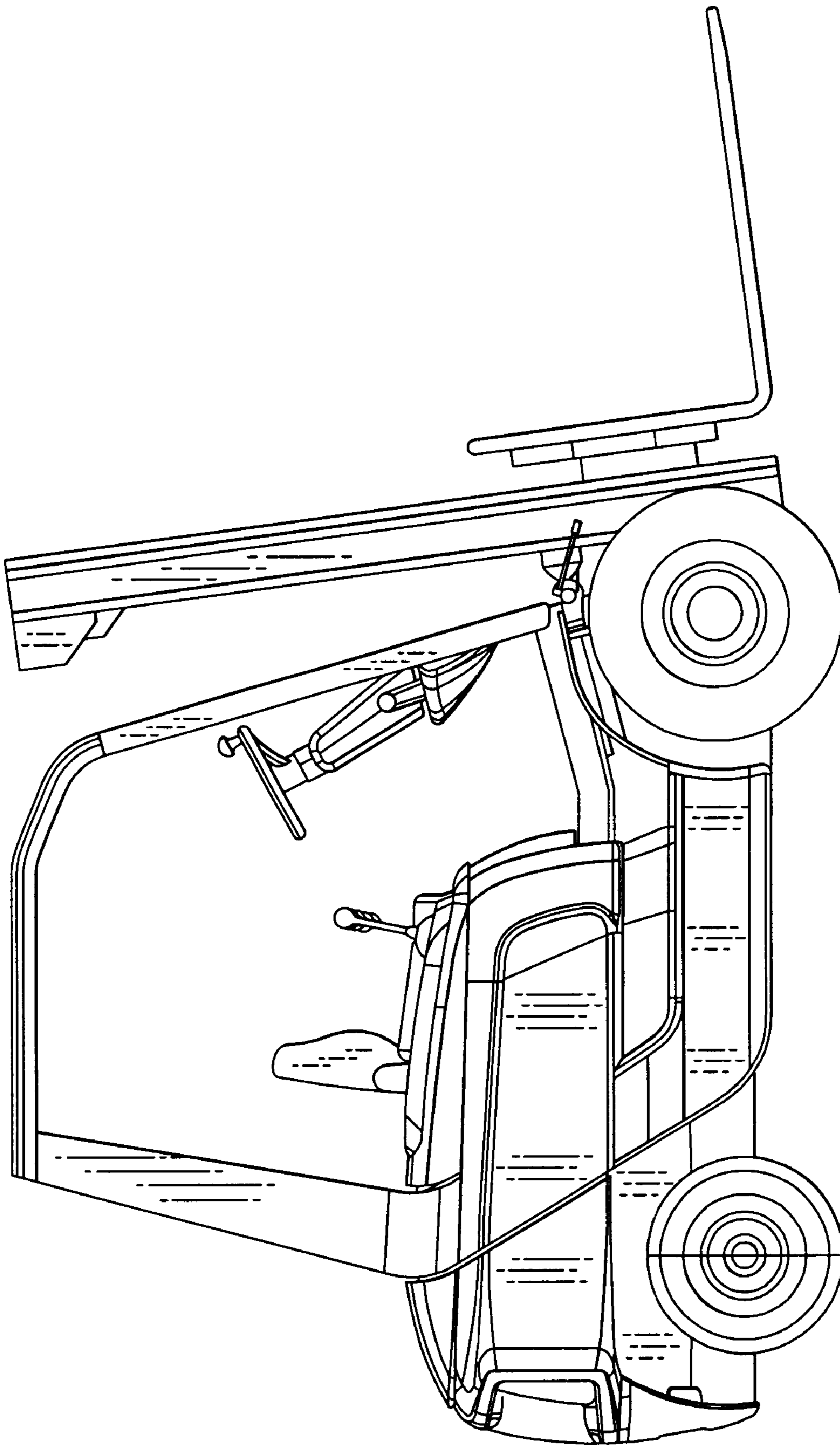

FIG. 7



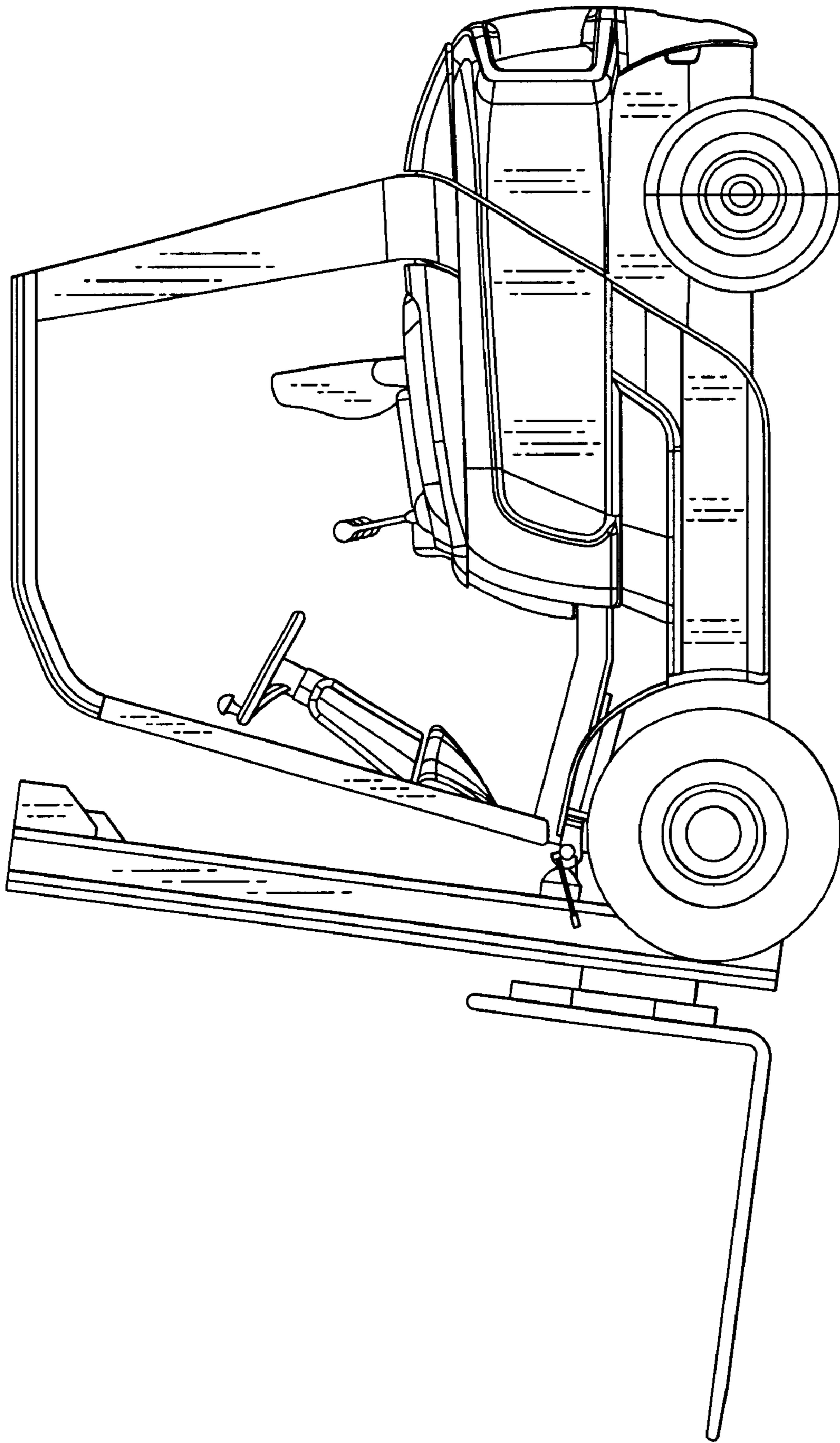
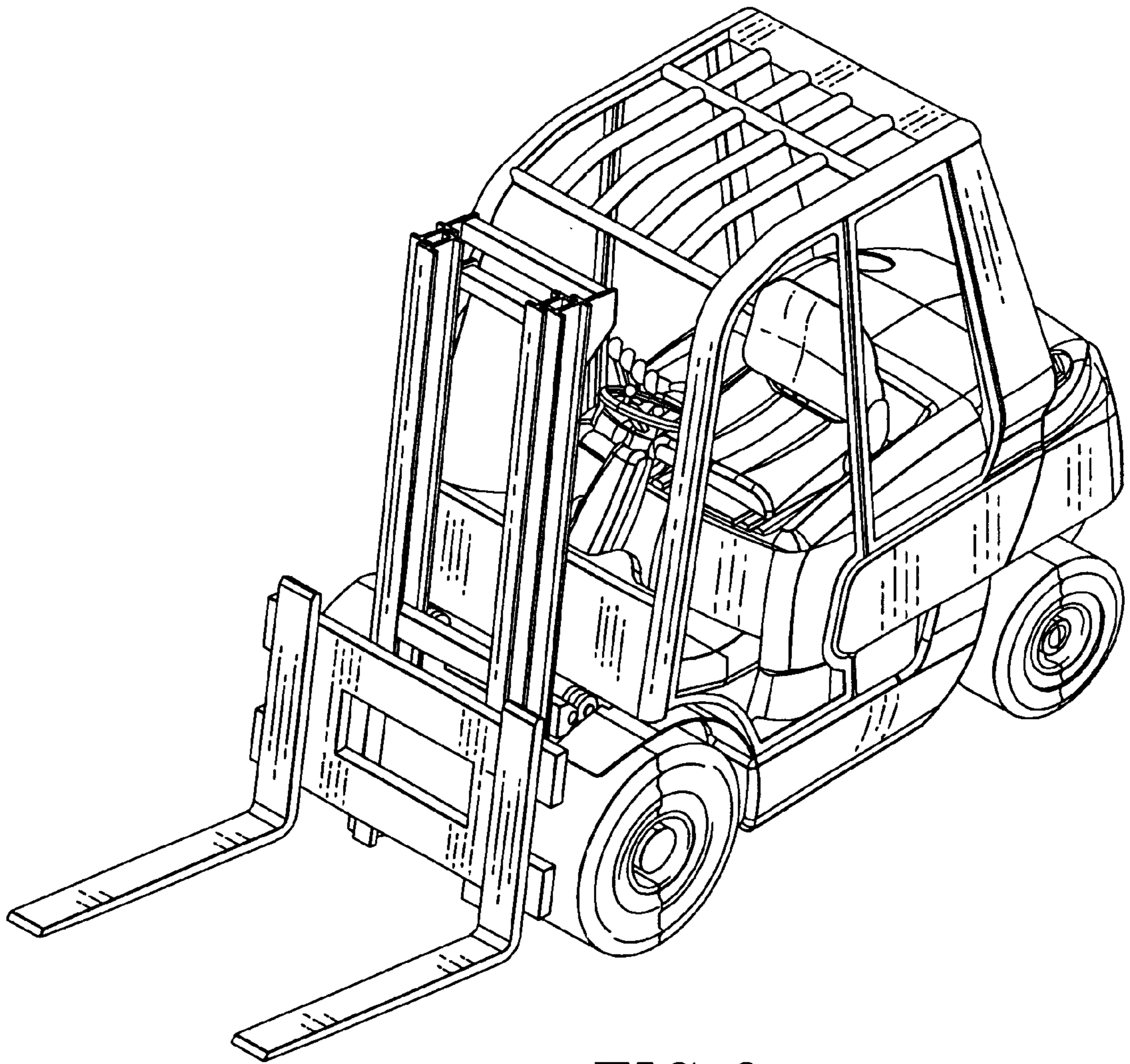

FIG. 8



*FIG. 9*

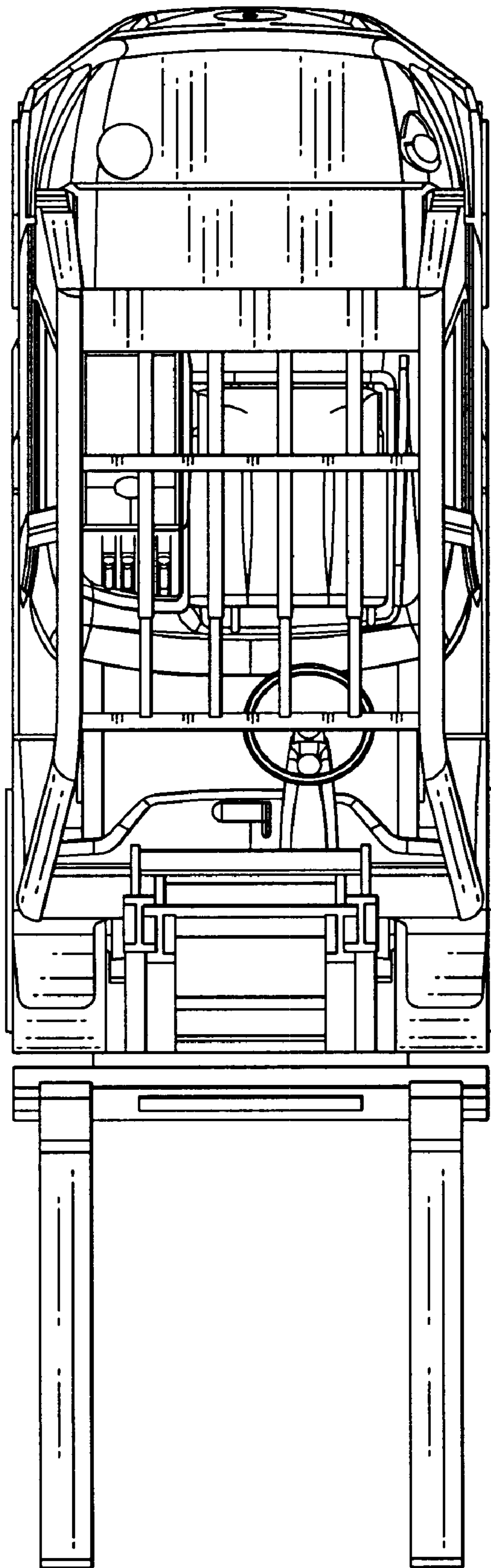
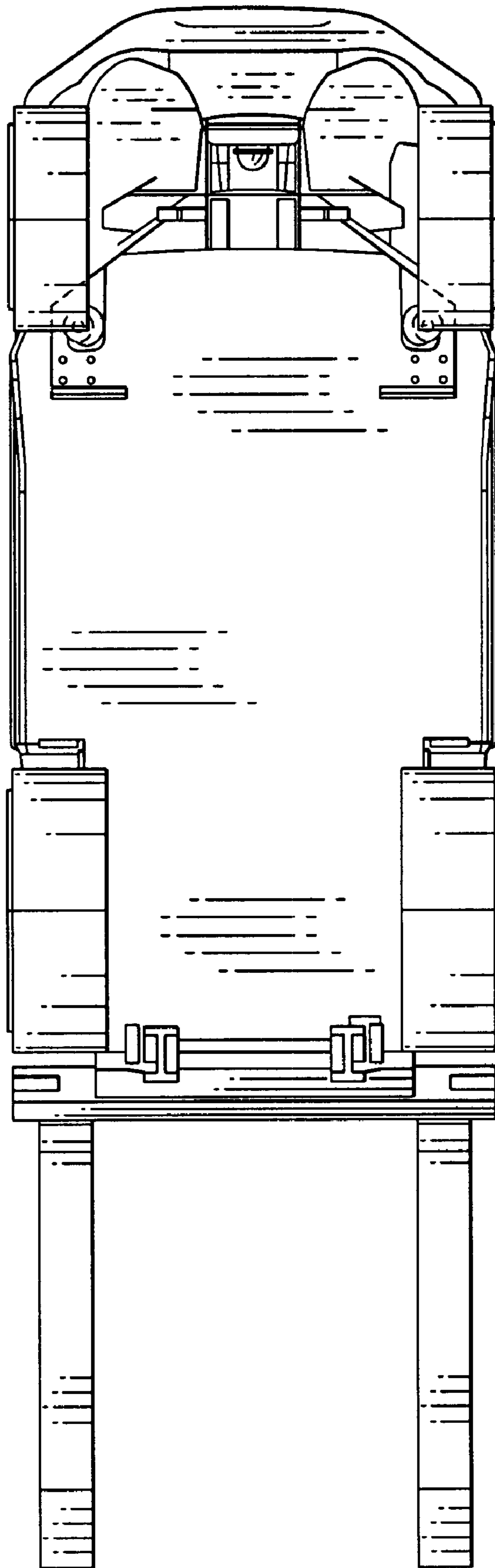
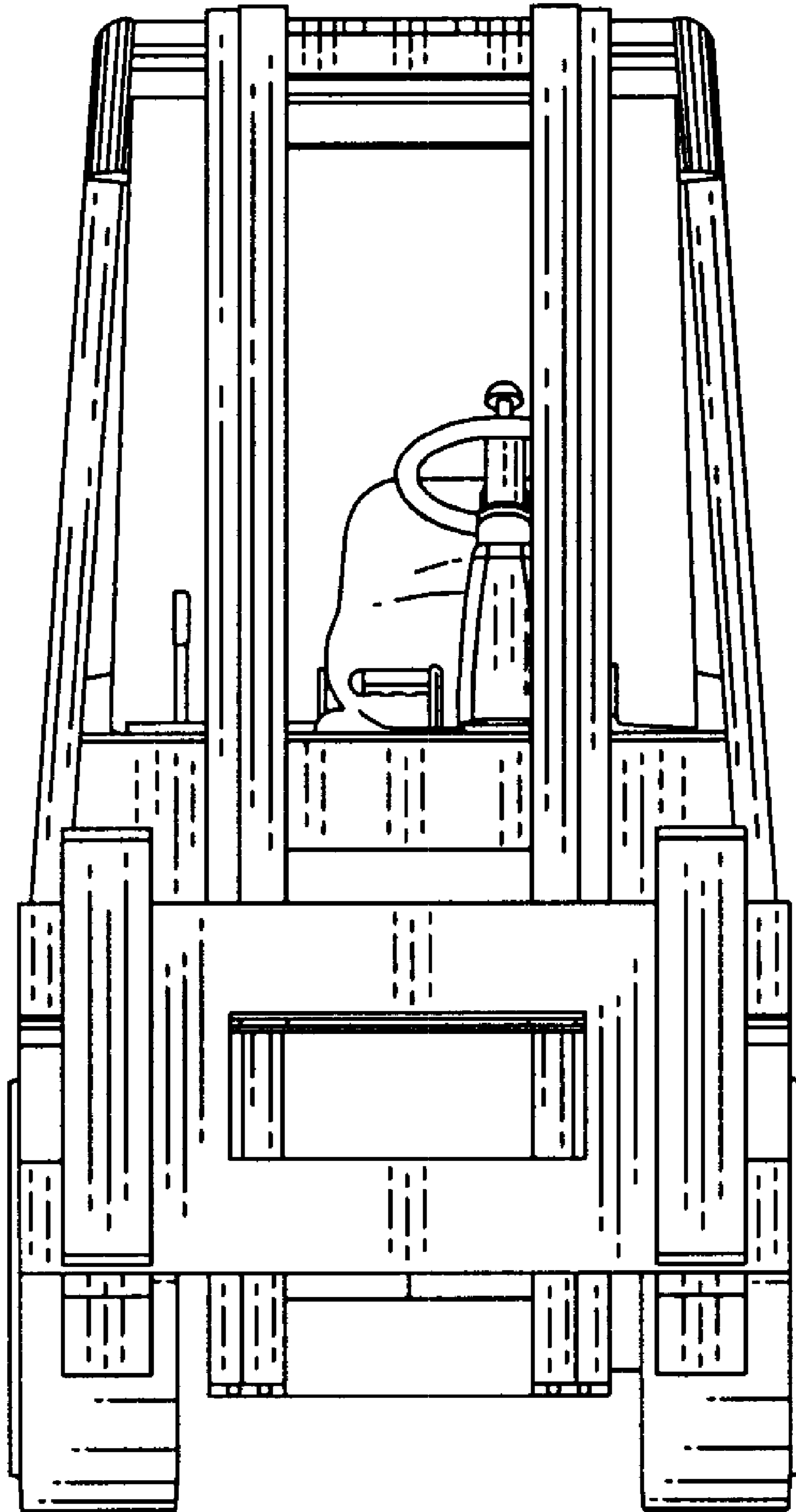

FIG. 10

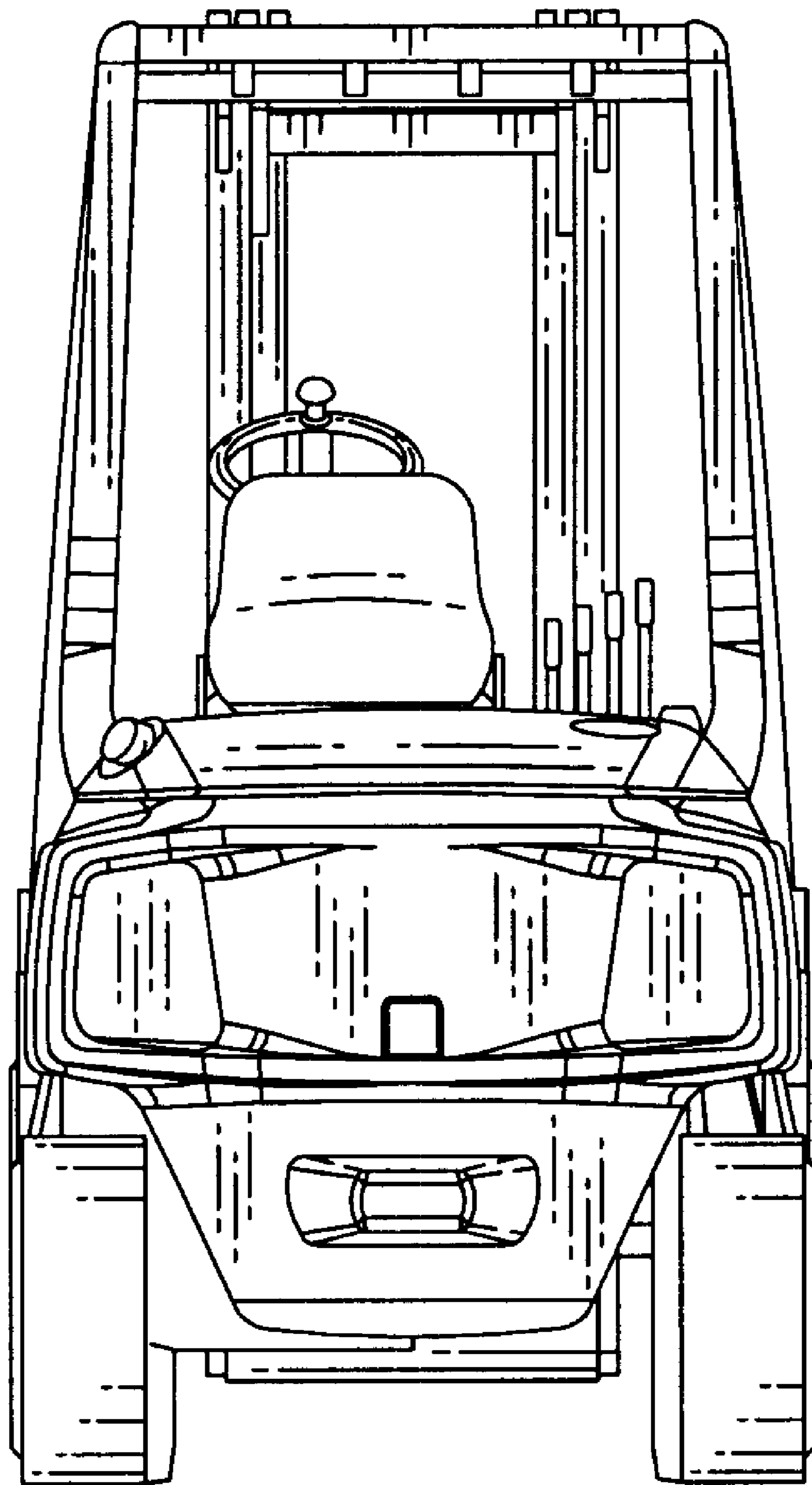

*FIG. 11*





*FIG. 12*



*FIG. 13*

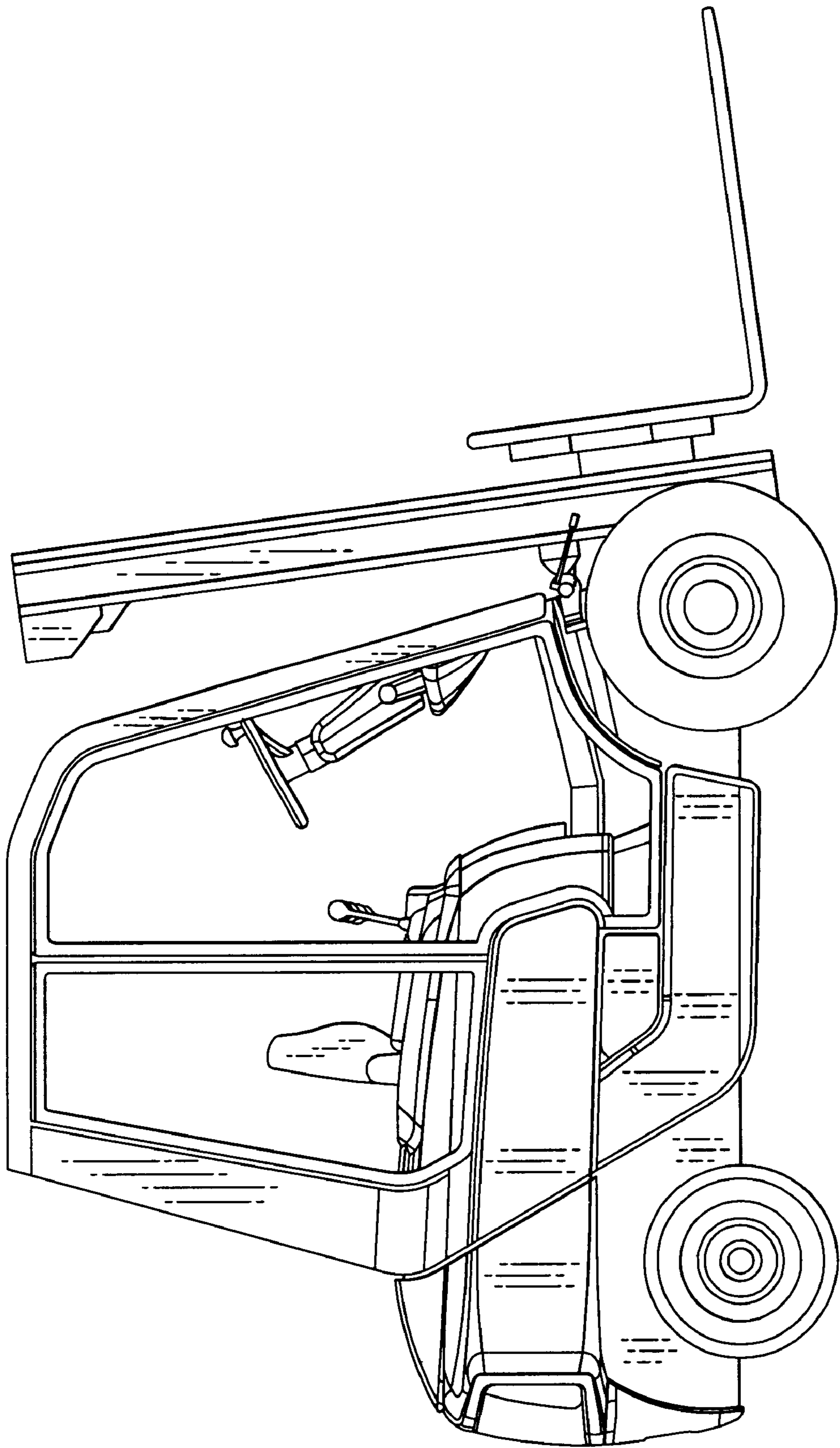

FIG. 14

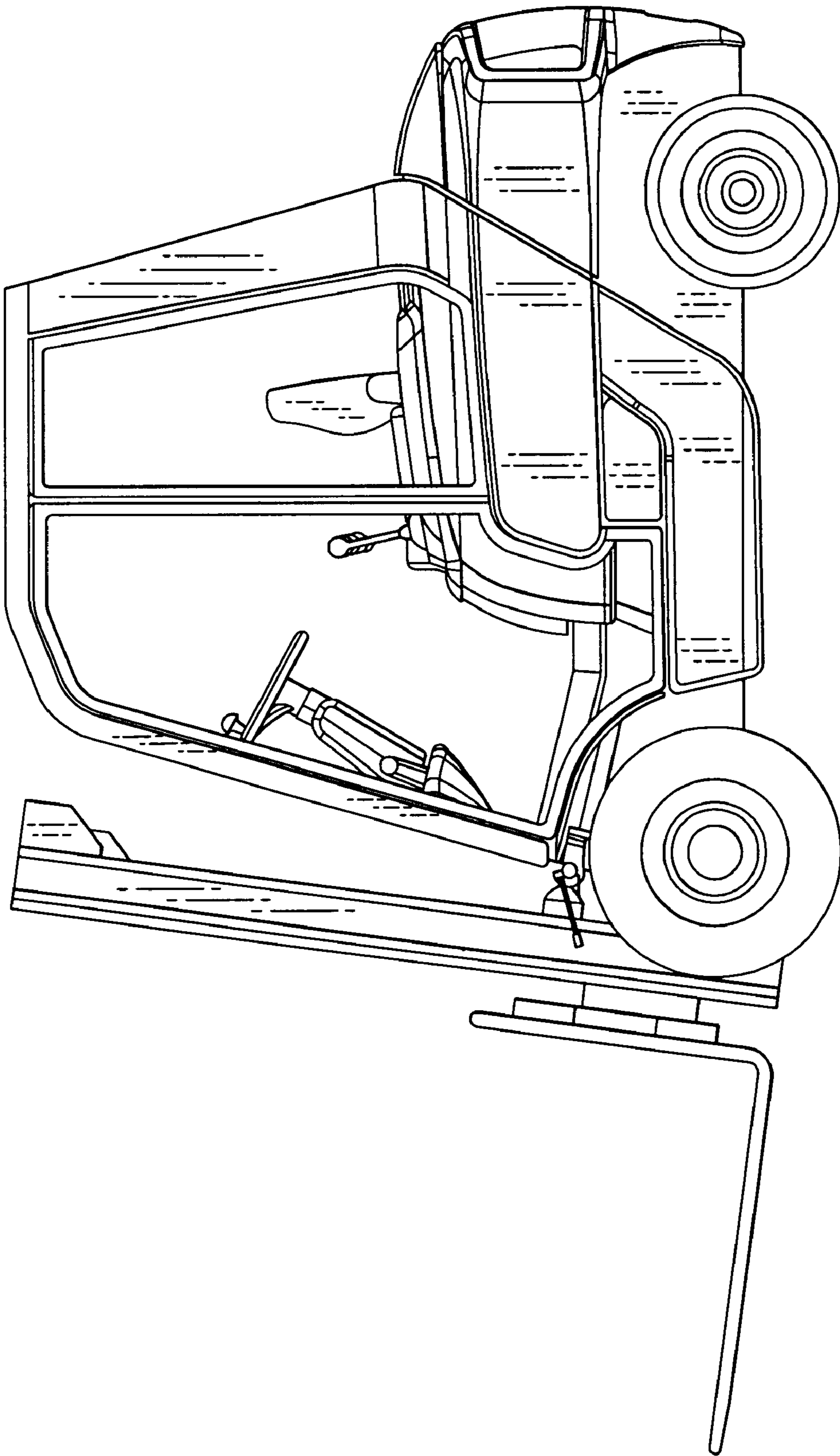

FIG. 15