



US00D468581S

(12) **United States Design Patent**
Short

(10) **Patent No.:** **US D468,581 S**

(45) **Date of Patent:** **** Jan. 14, 2003**

(54) **MIXER**

(75) Inventor: **Ellis G. Short**, Sydney, OH (US)

(73) Assignee: **Premark FEG L.L.C.**, Wilmington, DE (US)

(**) Term: **14 Years**

(21) Appl. No.: **29/159,713**

(22) Filed: **Apr. 26, 2002**

Related U.S. Application Data

(62) Division of application No. 29/145,442, filed on Jul. 23, 2001, now Pat. No. Des. 459,145.

(51) **LOC (7) Cl.** **31-00**

(52) **U.S. Cl.** **D7/379**

(58) **Field of Search** D7/376-386; 366/92-98,
366/185, 194, 197, 206, 241, 244

(56) **References Cited**

U.S. PATENT DOCUMENTS

D111,616 S	*	10/1938	Rosengren	D7/379
2,306,245 A	*	12/1942	Duke	366/98
D163,423 S	*	5/1951	Schimanski	D7/379
D180,952 S	*	9/1957	Kaempf	D7/379
D205,092 S	*	6/1966	Ewart	D7/379
4,790,665 A	*	12/1988	Hayashi	366/98
D362,994 S	*	10/1995	Ratermann et al.	D7/376
5,758,963 A	*	6/1998	Xie et al.	366/97
D456,145 S	*	6/2002	Short	D7/379

OTHER PUBLICATIONS

Univex Food Preparation Equipment price list/catalog; Nov. 1, 2001; p. 3; Planetary Mixer SRM60+ floor model mixer PN 1064402; bottom left of page.*

Thunderbird bakery equipment & food machines flyer; copyright Jul. 1999; Planetary mixers ARM-02 and ARM-60 at the top and bottom of the page.*

U.S. Trademark Reg. No. 2,206,296, Dec. 1998.

U.S. Trademark Reg. No. 2,194,508, Oct. 1998.

U.S. Trademark Reg. No. 1,553,469, Aug. 1989.

Hobart Food Equipment N-50 Mixer; Jun. 2000; 1 Page.

Hobart Food Equipment A-120 Mixer; Jun. 2000; 1 Page.

Hobart Food Equipment A-200 Mixer; Jun. 2000; 1 Page.

The Edge publication, vol. Six, Spring 1994; 16 Pages.

* cited by examiner

Primary Examiner—Caron D. Veynar

(74) *Attorney, Agent, or Firm*—Thompson Hine LLP

(57) **CLAIM**

The ornamental design for a mixer, as shown and described.

DESCRIPTION

FIG. 1 is a perspective view of a mixer showing my new design.

FIG. 2 is a front elevation view of the mixer of FIG. 1;

FIG. 3 is a left elevation view of the mixer of FIG. 1;

FIG. 4 is a rear elevation view of the mixer of FIG. 1;

FIG. 5 is a right elevation view of the mixer of FIG. 1; and,

FIG. 6 is a top view of the mixer of FIG. 1.

The broken lines shown in FIGS. 1-6 are for illustrative purposes only and form no part of the claimed design.

1 Claim, 6 Drawing Sheets

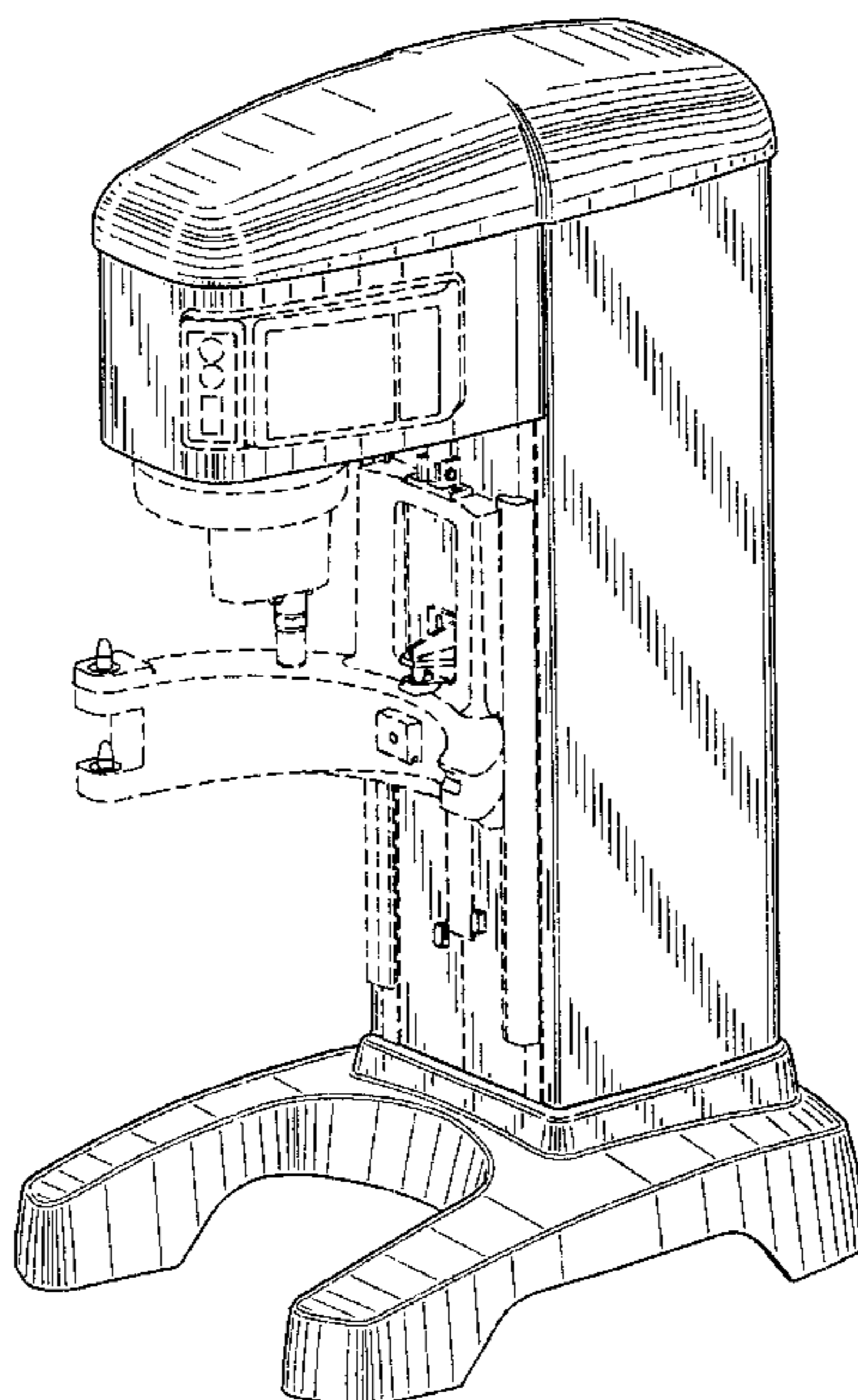

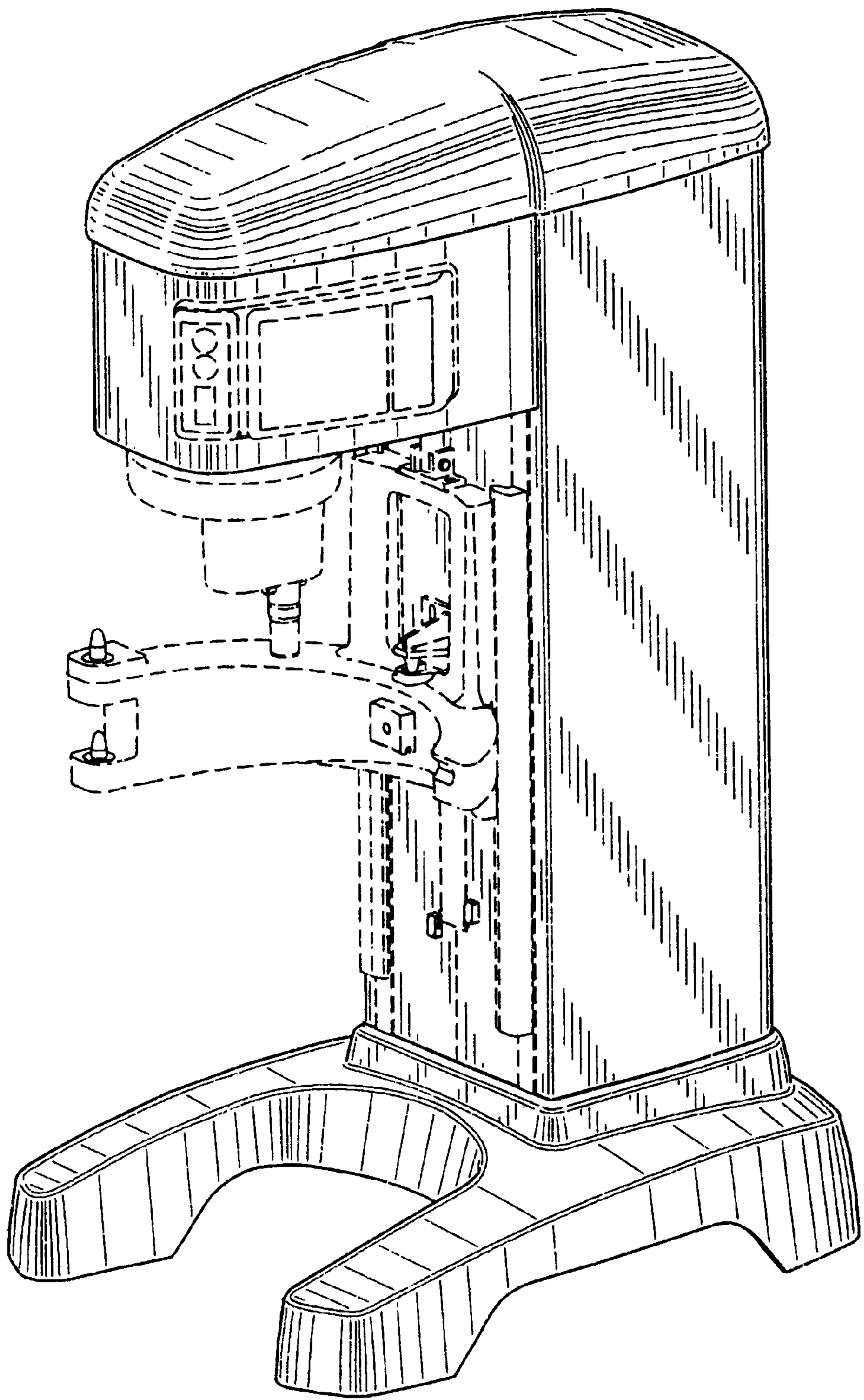

FIG. 1

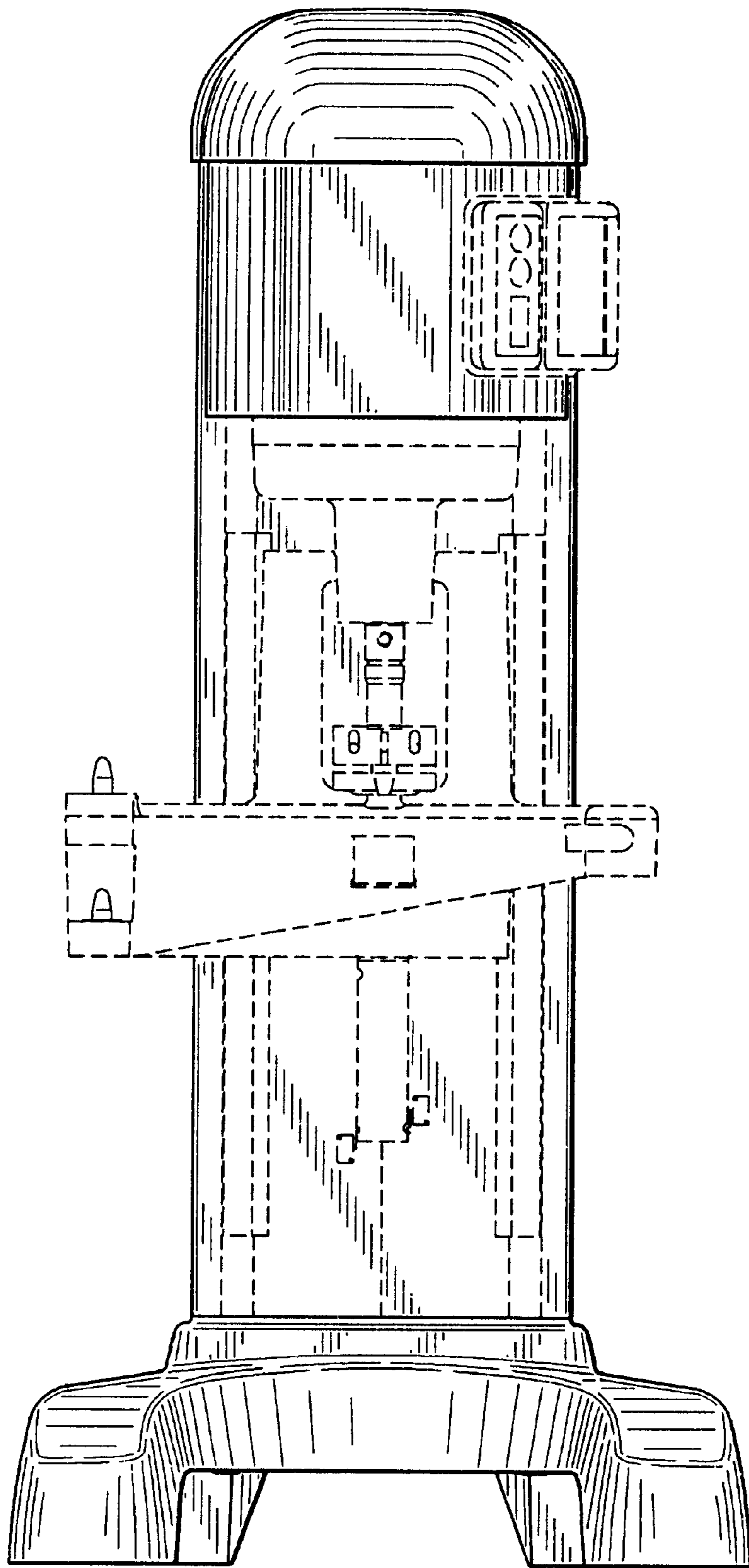

FIG. 2

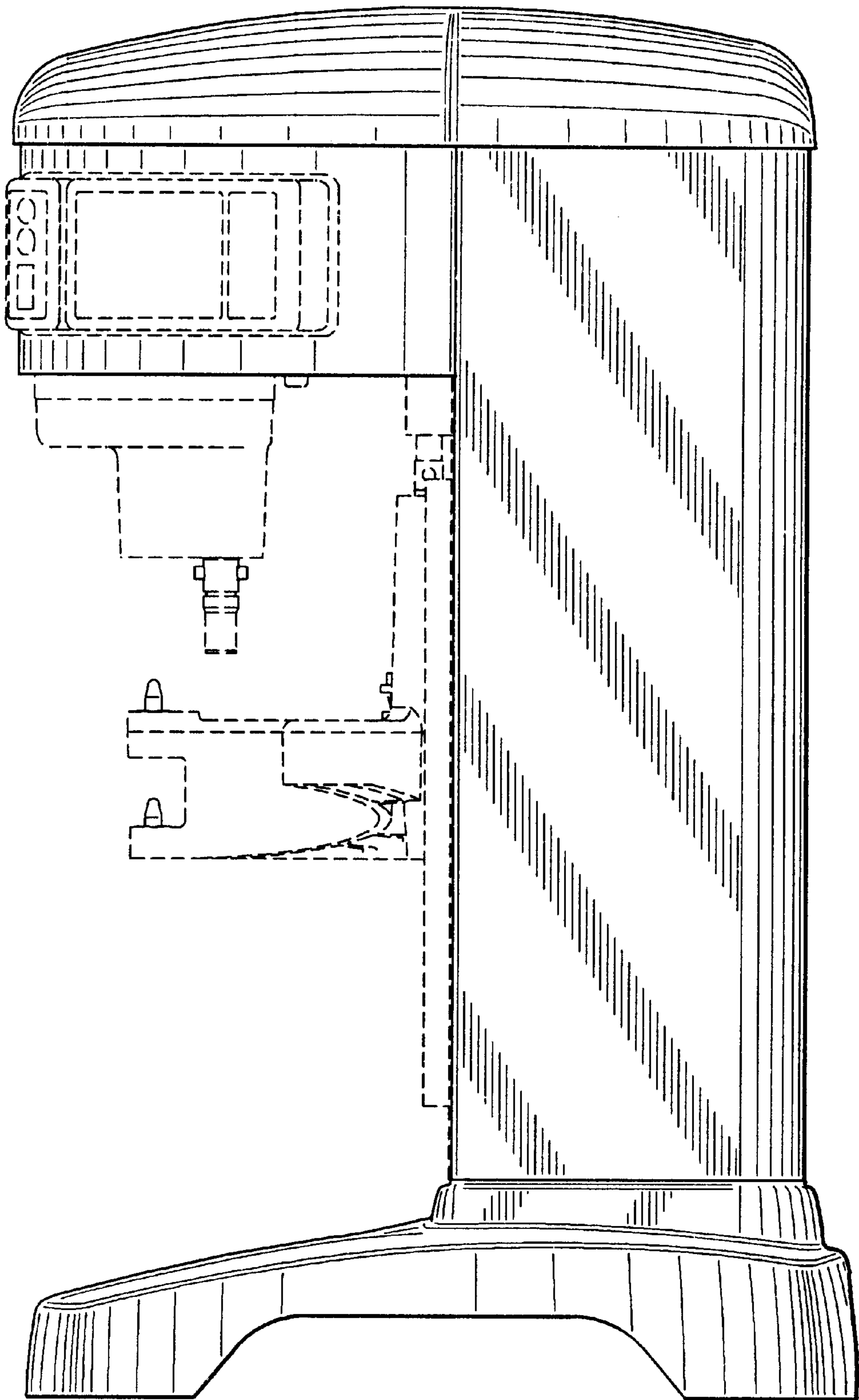

FIG. 3

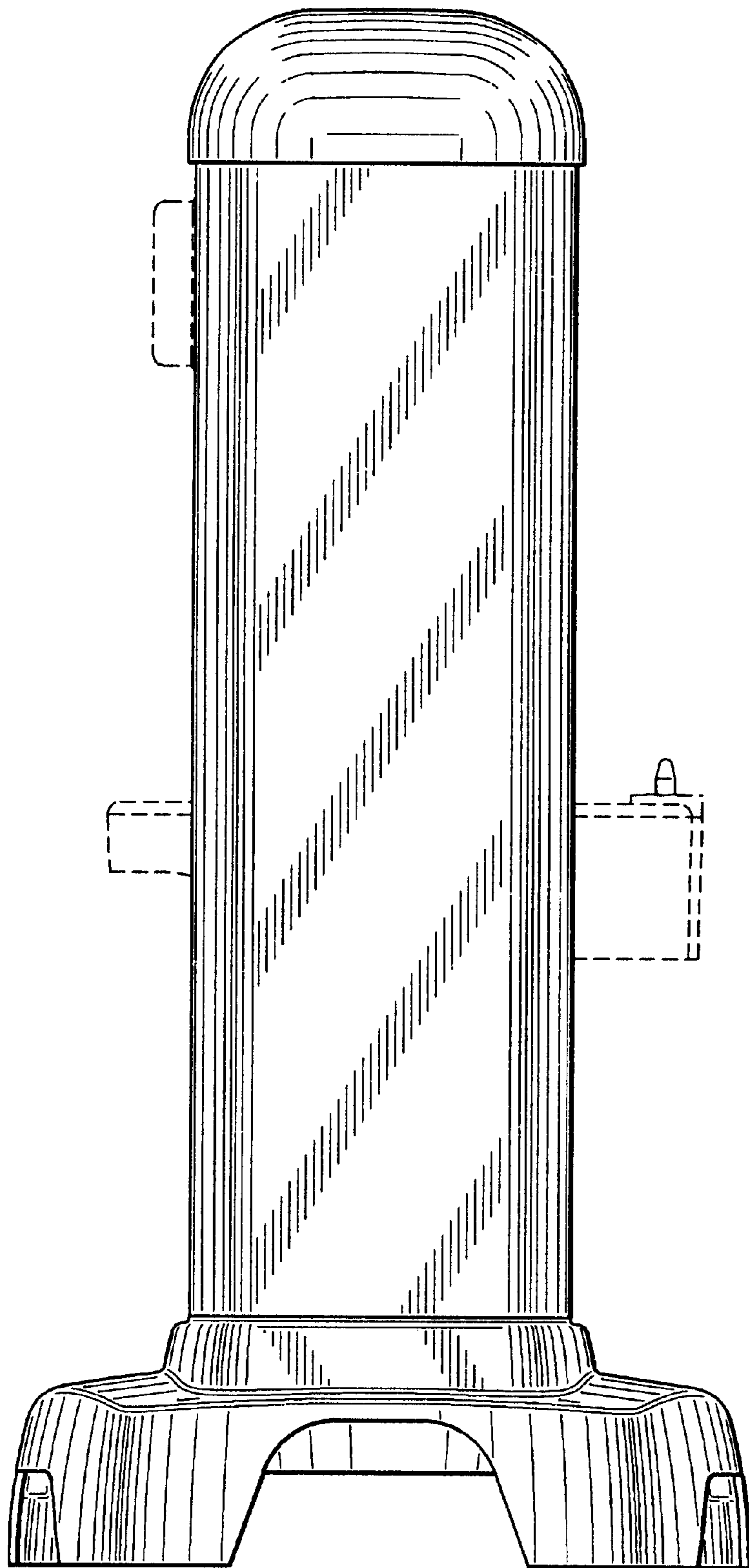

FIG. 4

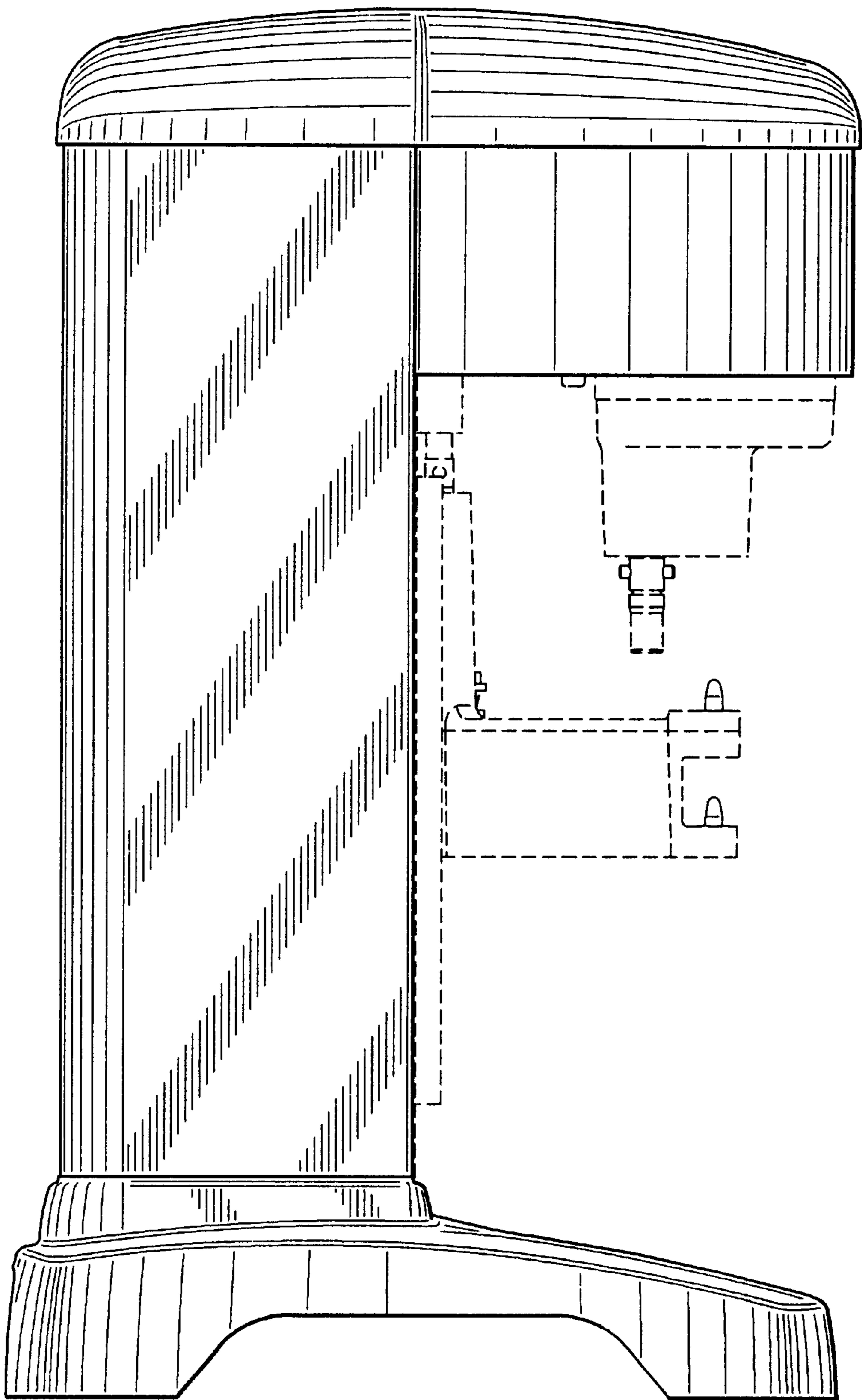

FIG. 5

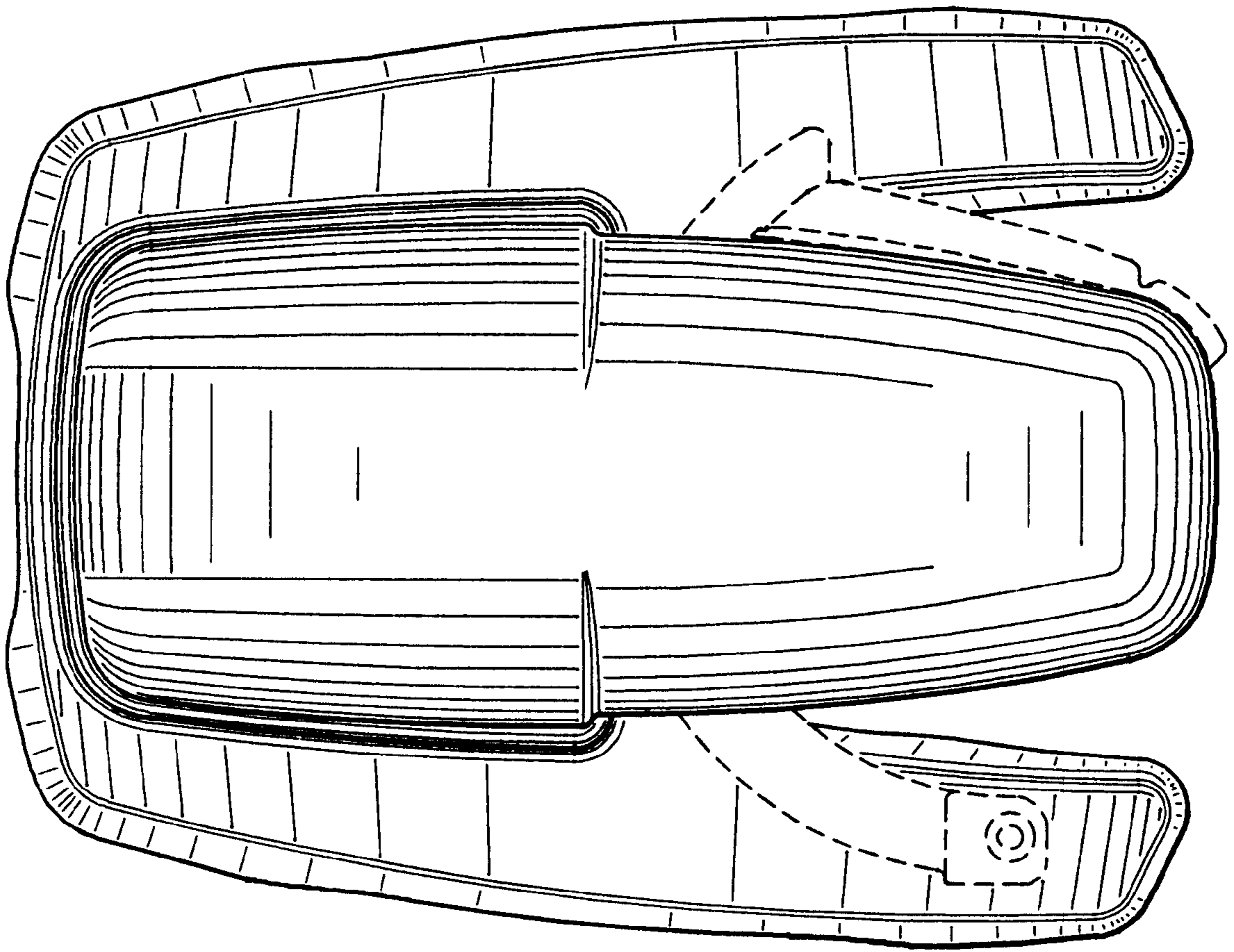

FIG. 6