



US00D468547S

(12) **United States Design Patent**
Cadotte et al.

(10) **Patent No.:** **US D468,547 S**
(45) **Date of Patent:** **** Jan. 14, 2003**

(54) **SNOWMOBILE SEAT**

(75) Inventors: **Germain Cadotte**, St-Elie d'Orford (CA); **Emmanuel Rius**, Sherbrooke (CA)

(73) Assignee: **Bombardier Inc.**, Montreal (CA)

(**) Term: **14 Years**

(21) Appl. No.: **29/132,849**

(22) Filed: **Nov. 17, 2000**

D230,585 S	3/1974	Rose	D12/7
D232,674 S	* 9/1974	Scott	D6/354
D239,164 S	3/1976	Smith	D12/7
D246,879 S	* 1/1978	Hanagan	D6/354
4,124,248 A	* 11/1978	Mayer	297/204
D264,830 S	6/1982	Ishiyama	D12/7
D273,185 S	3/1984	Ishiyama	D12/7
D278,892 S	5/1985	Kobayashi	D12/7
D314,525 S	2/1991	Matsue	D12/7
D333,110 S	2/1993	Mogi et al.	D12/7
D342,044 S	12/1993	Hornai	D12/7
D389,780 S	1/1998	Komatsu et al.	D12/7
D438,821 S	* 3/2001	Cadotte et al.	D12/7

Related U.S. Application Data

(62) Division of application No. 29/109,236, filed on Aug. 11, 1999, now Pat. No. Des. 438,821.

(30) **Foreign Application Priority Data**

Feb. 12, 1999 (CA) 1999-0393

(51) **LOC (7) Cl.** **06-01**

(52) **U.S. Cl.** **D6/354**

(58) **Field of Search** D12/7, 10, 110, D12/114; D6/354; 297/204, 195, 243, 284, 195.1; 180/182, 184-186, 190, 193-194; 280/845

(56) **References Cited**

U.S. PATENT DOCUMENTS

D217,862 S	6/1970	Johnson	D12/7
D222,316 S	* 10/1971	Wilkins	D6/354
D222,858 S	* 1/1972	MacKeen et al.	D6/354
D223,604 S	* 5/1972	MacKeen et al.	D6/354
D223,709 S	* 5/1972	Lapointe	D6/354
D224,005 S	* 6/1972	MacKeen	D12/7
D225,105 S	11/1972	McAkeen et al.	D12/7
D225,484 S	* 12/1972	Purdy	D6/354
D228,754 S	10/1973	Mango	D12/7

* cited by examiner

Primary Examiner—Stacia Cadmus

(74) *Attorney, Agent, or Firm*—Pillsbury Winthrop LLP

(57) **CLAIM**

The ornamental design for a snowmobile seat, as shown and described.

DESCRIPTION

FIG. 1 is a frontal perspective view of a snowmobile seat according to the present design;
FIG. 2 is a right side view of the snowmobile seat of FIG. 1;
FIG. 3 is a front elevation view of the snowmobile seat of FIG. 1;
FIG. 4 is a rear elevation view of the snowmobile seat of FIG. 1;
FIG. 5 is a top plan view of the snowmobile seat of FIG. 1; and,
FIG. 6 is a left side view of the snowmobile seat of FIG. 1.
Where included, broken lines showing structure are for illustrative purposes only and form no part of the claimed design.

1 Claim, 5 Drawing Sheets

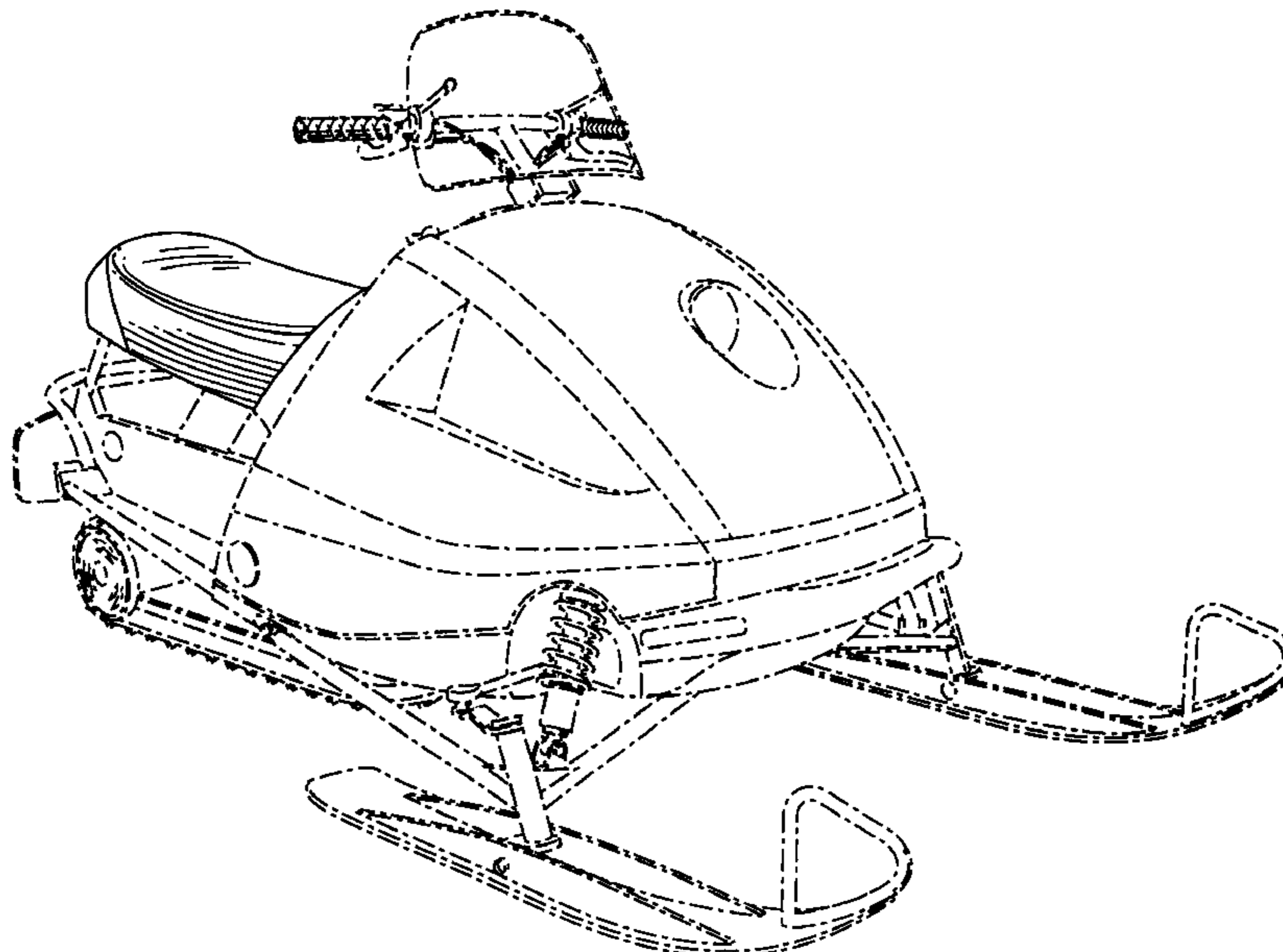

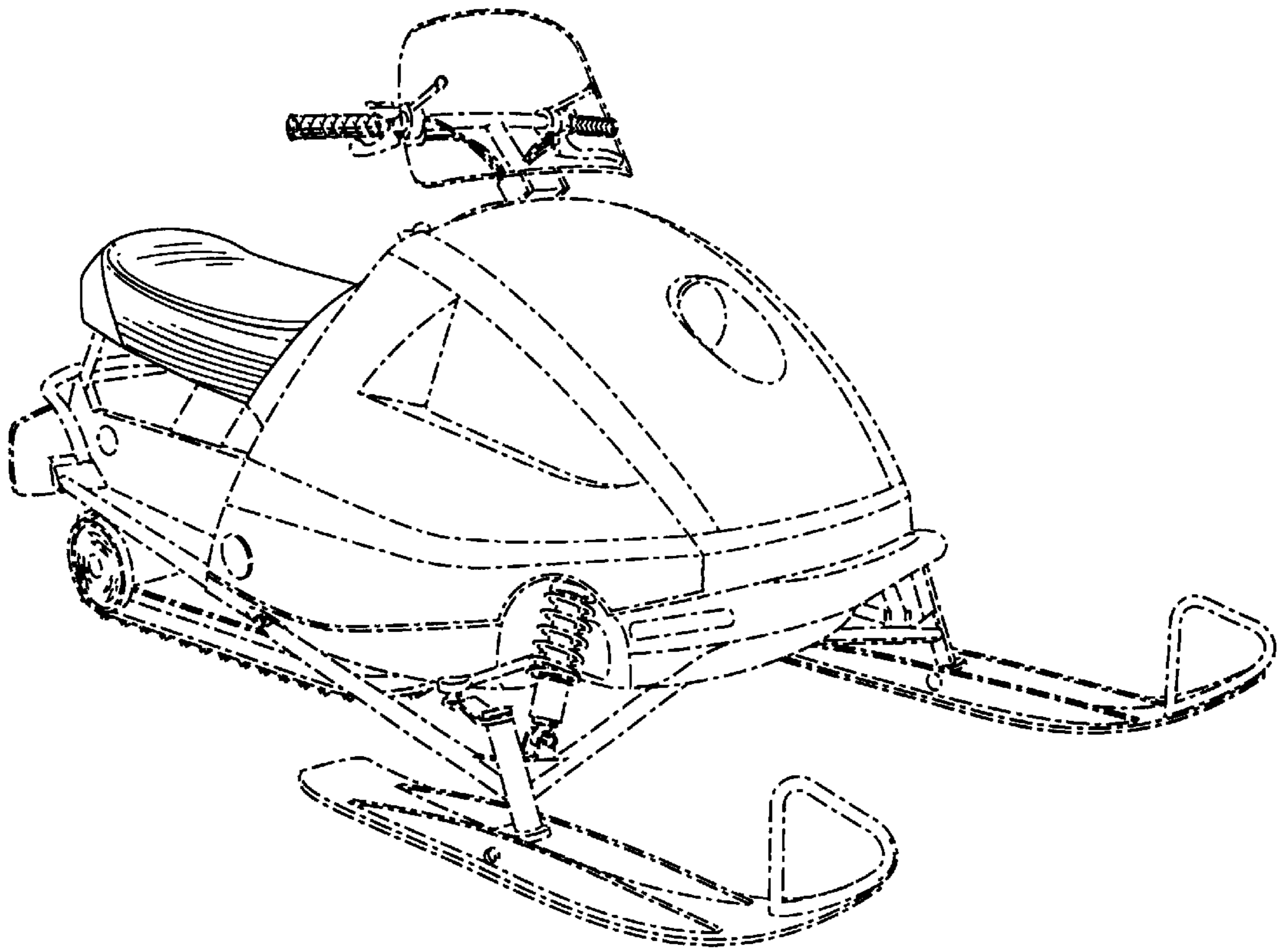

Fig. 1

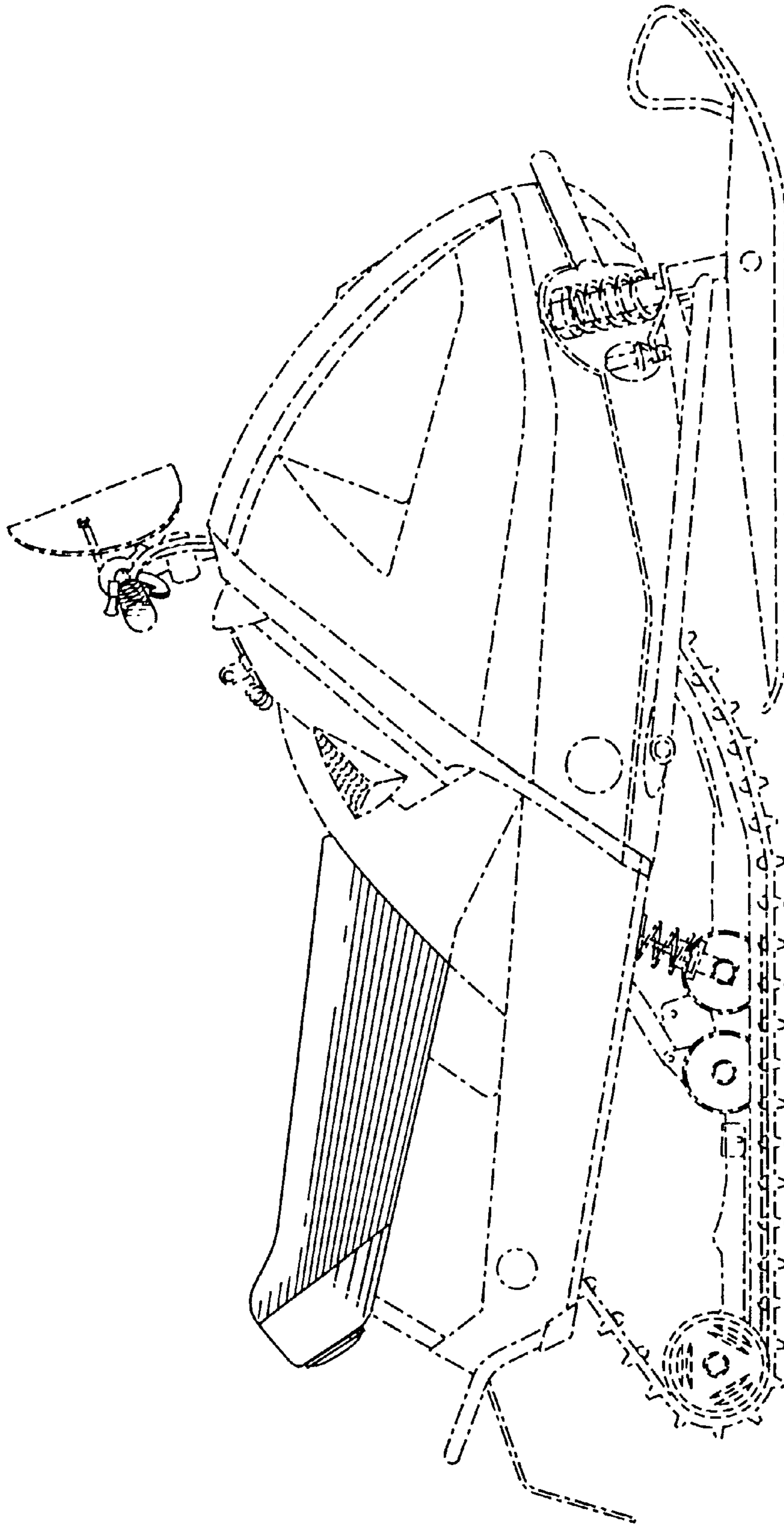

Fig. 2

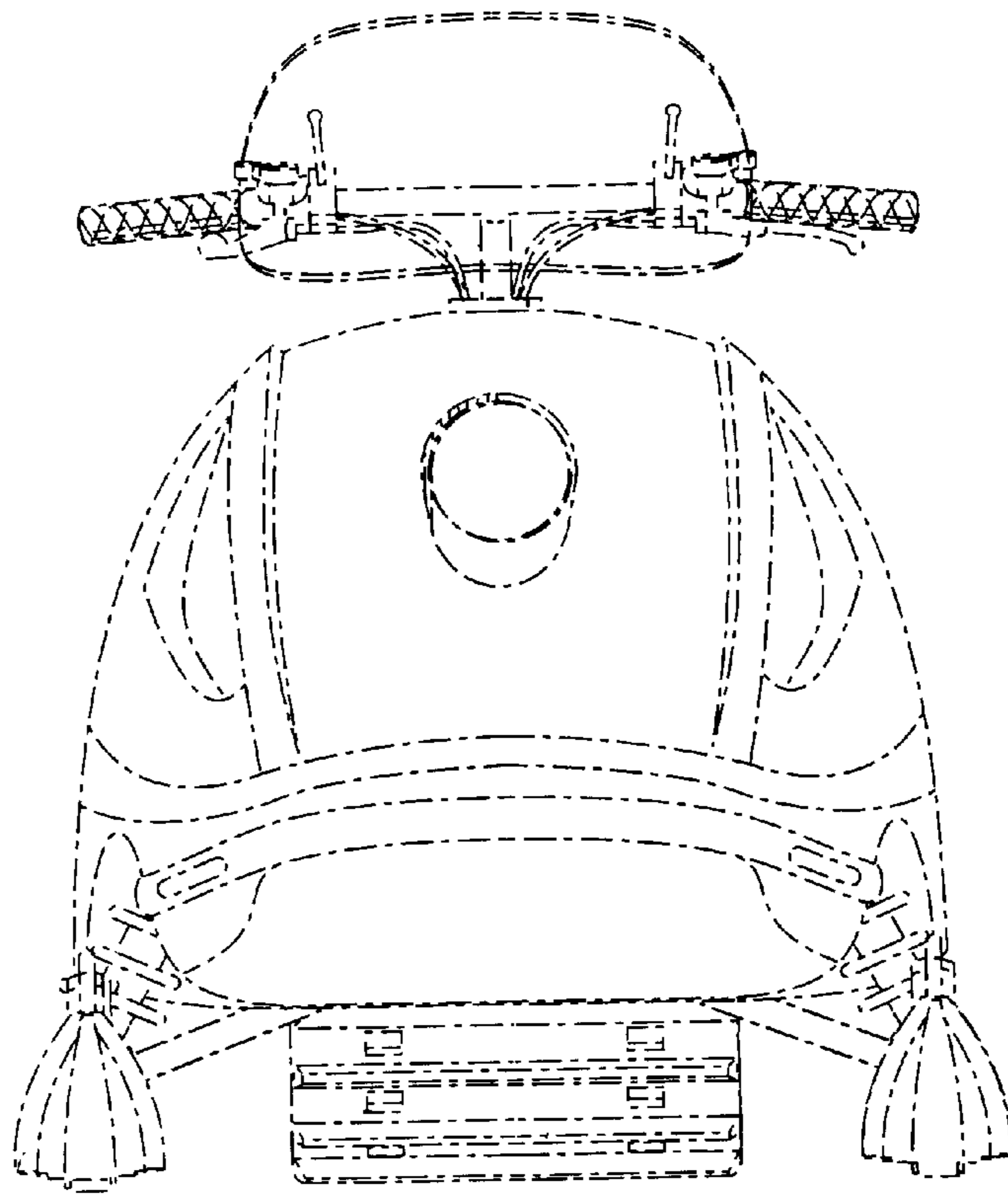

Fig. 3

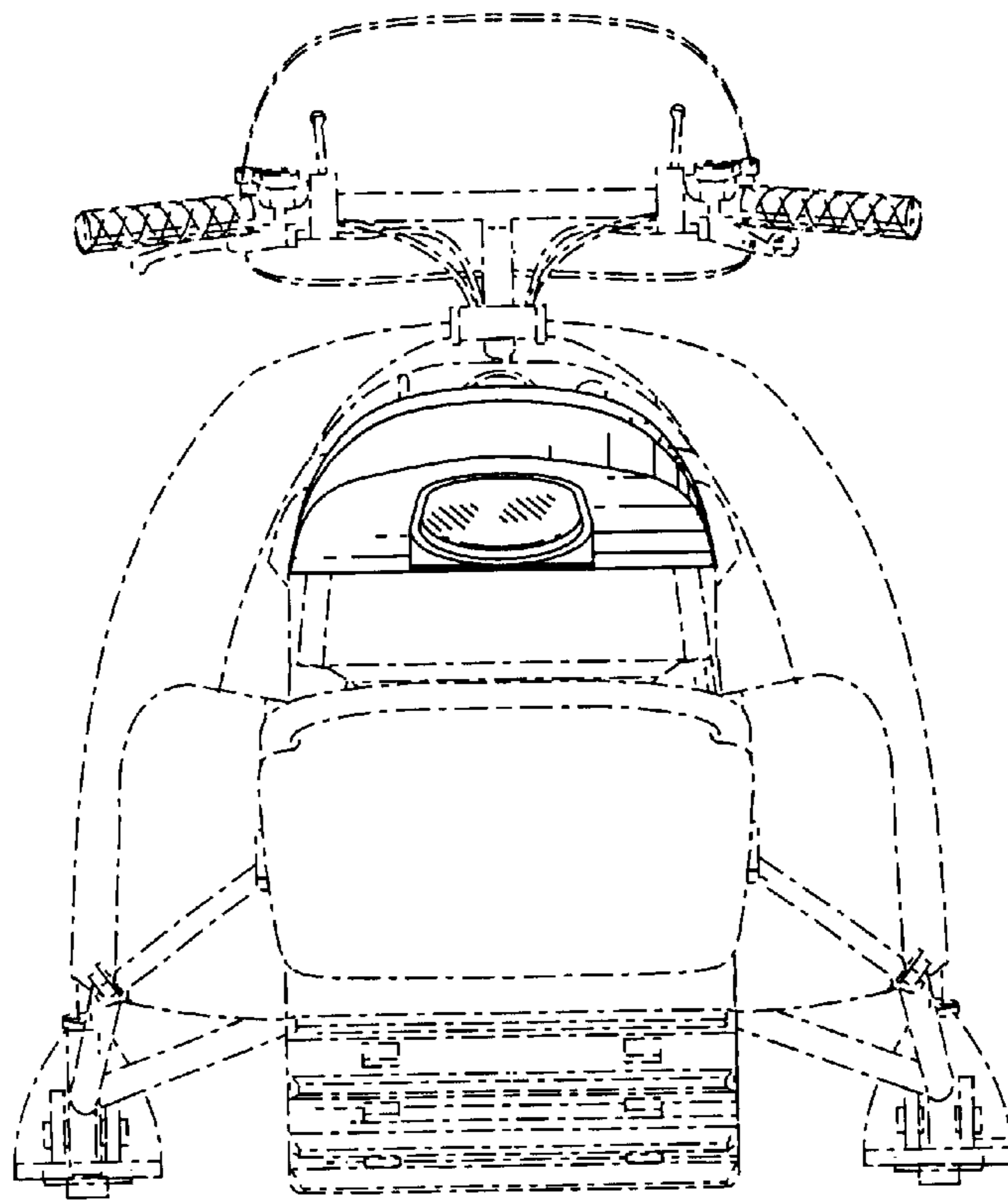

Fig. 4

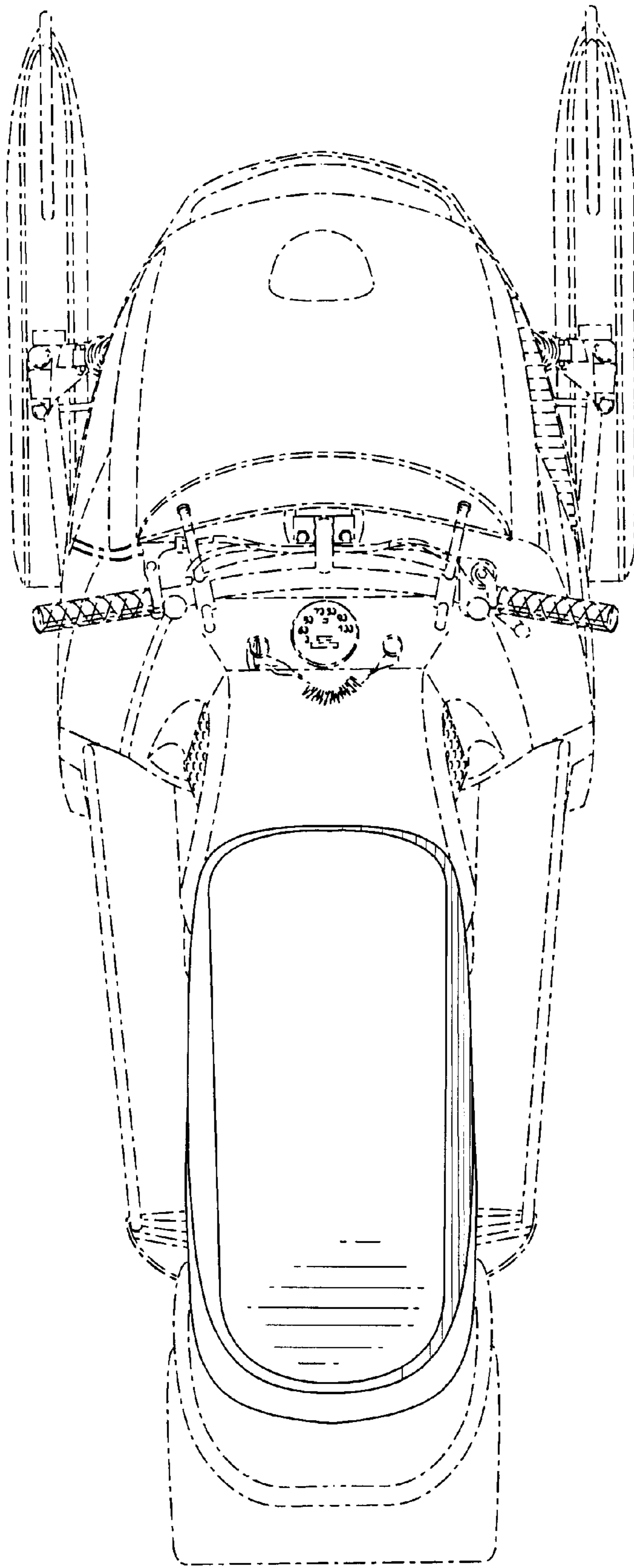

Fig. 5

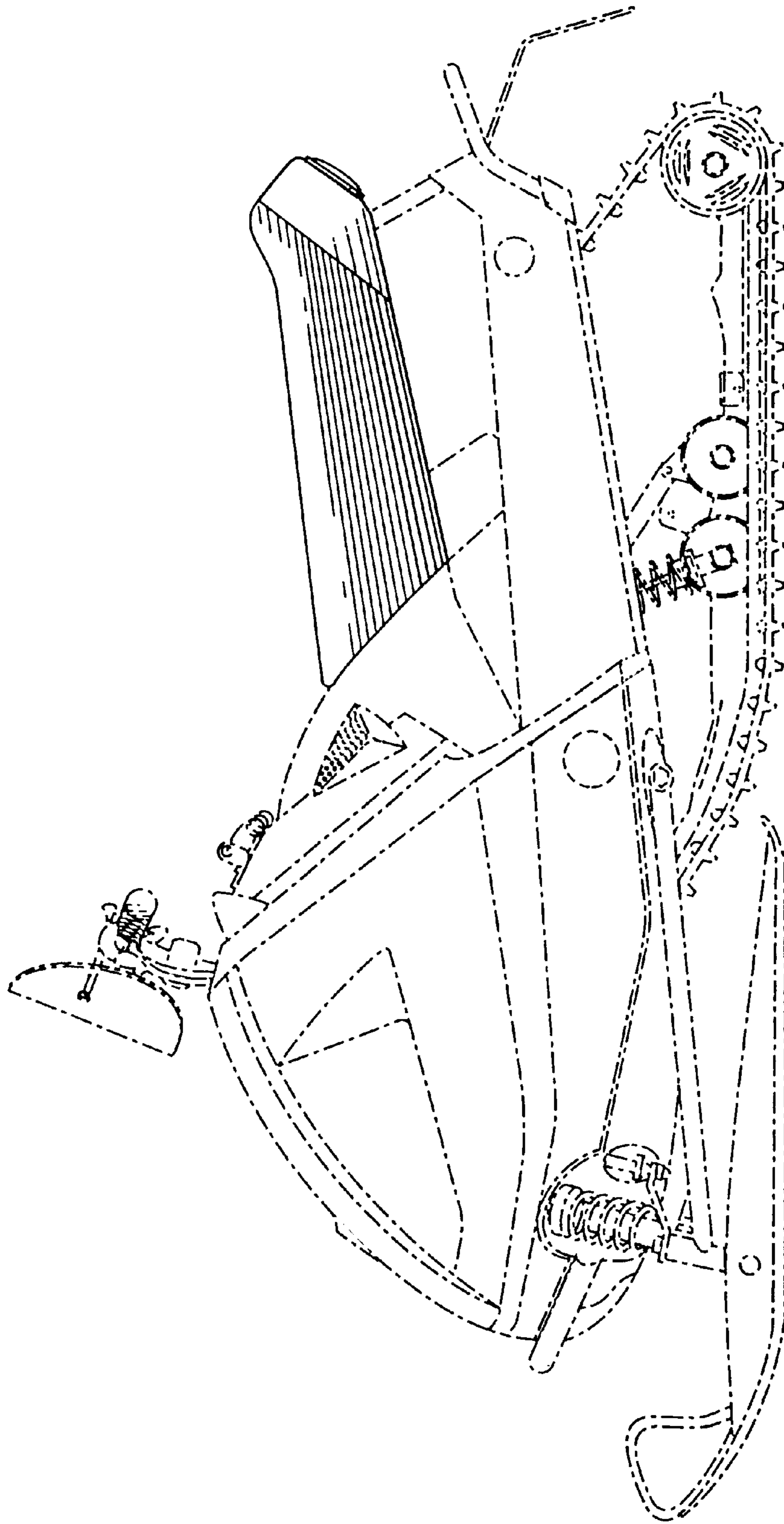

Fig. 6