

US00D468247S

(12) **United States Design Patent**  
**Vandillen**

(10) **Patent No.:** **US D468,247 S**  
(45) **Date of Patent:** **\*\* Jan. 7, 2003**

(54) **DOOR ARRANGEMENT FOR A VEHICLE**

(76) Inventor: **Sieto Vandillen**, 47 W. Minges Rd.,  
Battle Creek, MI (US) 49015

(\*\*) Term: **14 Years**

(21) Appl. No.: **29/154,066**

(22) Filed: **Jan. 16, 2002**

(51) **LOC (7) Cl.** ..... **12-16**

(52) **U.S. Cl.** ..... **D12/196**

(58) **Field of Search** ..... D12/196, 90-92,  
D12/86; 296/185

(56) **References Cited**

**U.S. PATENT DOCUMENTS**

D406,551 S	3/1999	Nesbitt et al.	.....	D12/92
D413,081 S	* 8/1999	Nesbitt et al.	.....	D12/91
D430,065 S	* 8/2000	Carlson et al.	.....	D12/92
D430,821 S	* 9/2000	Carlson et al.	.....	D12/92
D432,950 S	* 10/2000	Sugita	.....	D12/91
D443,574 S	* 12/2001	Liear	.....	D12/196
D453,712 S	* 2/2002	Pasteiner et al.	.....	D12/91
D455,983 S	* 4/2002	Carlson	.....	D12/92

\* cited by examiner

*Primary Examiner*—Melody N. Brown

(74) *Attorney, Agent, or Firm*—Flynn, Thiel, Boutell &  
Tanis, P.C.

(57) **CLAIM**

The ornamental design of a door arrangement for a vehicle,  
as shown and described.

**DESCRIPTION**

FIG. 1 is a perspective view of a door arrangement for a  
vehicle showing new design;

FIG. 2 is a perspective view of the door arrangement of FIG.  
1 with a first door in an open position and a second door  
partially opened;

FIG. 3 is a perspective view of the embodiment of FIG. 1  
with the doors in fully open positions;

FIG. 4 is a perspective view of the door arrangement of  
FIGS. 1-3 with a ramp identified by dash lines that is  
deployed for illustrative purposes only;

FIG. 5 is a top perspective view of the door arrangement  
shown in FIG. 1;

FIG. 6 is a rear elevational view of the door arrangement of  
FIGS. 4 and 5; and,

FIG. 7 is a front elevational view of the door arrangement  
shown in FIGS. 4-6.

In the drawings, the structure that is depicted by broken lines  
is solely for environmental purposes, and does not constitute  
part of the present invention.

**1 Claim, 6 Drawing Sheets**

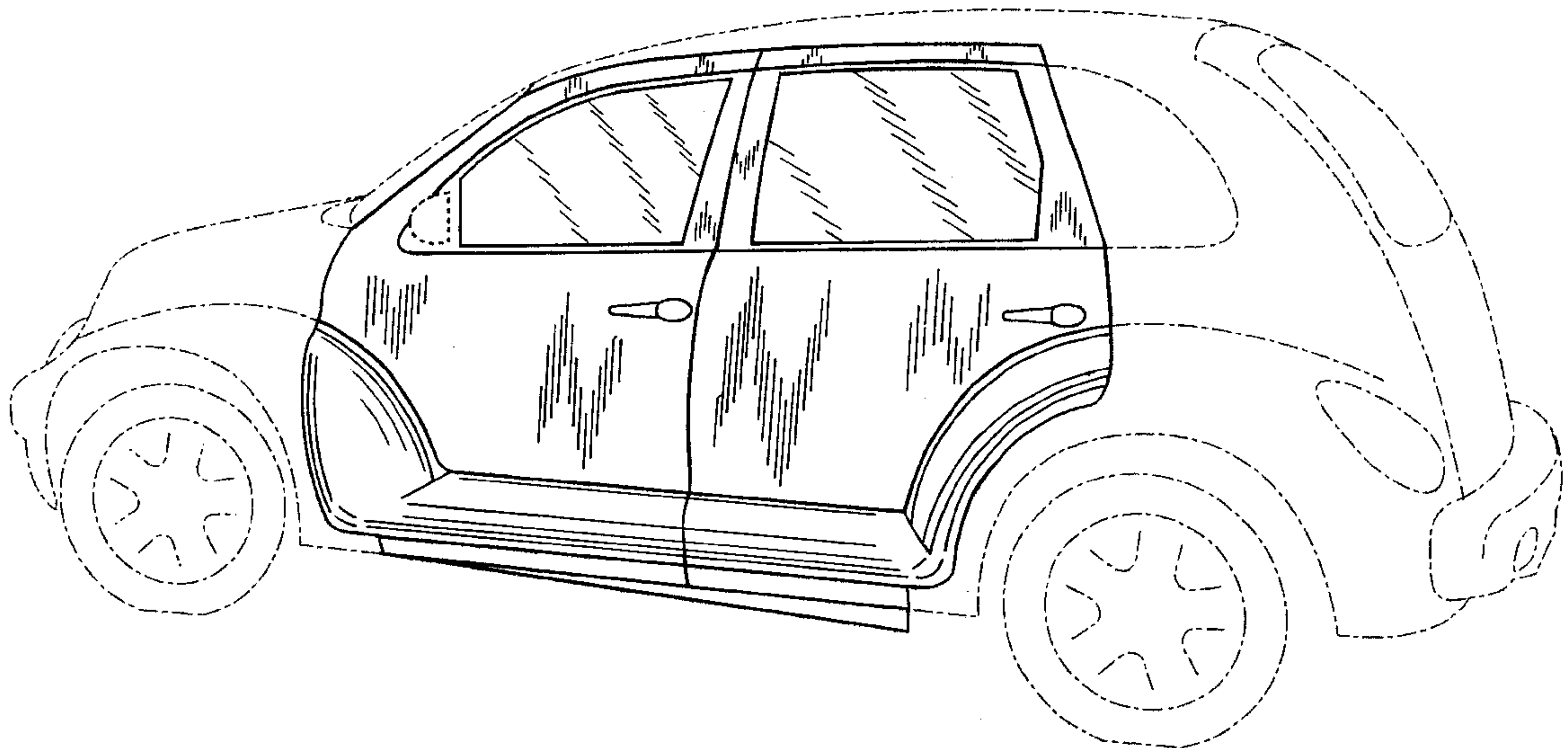

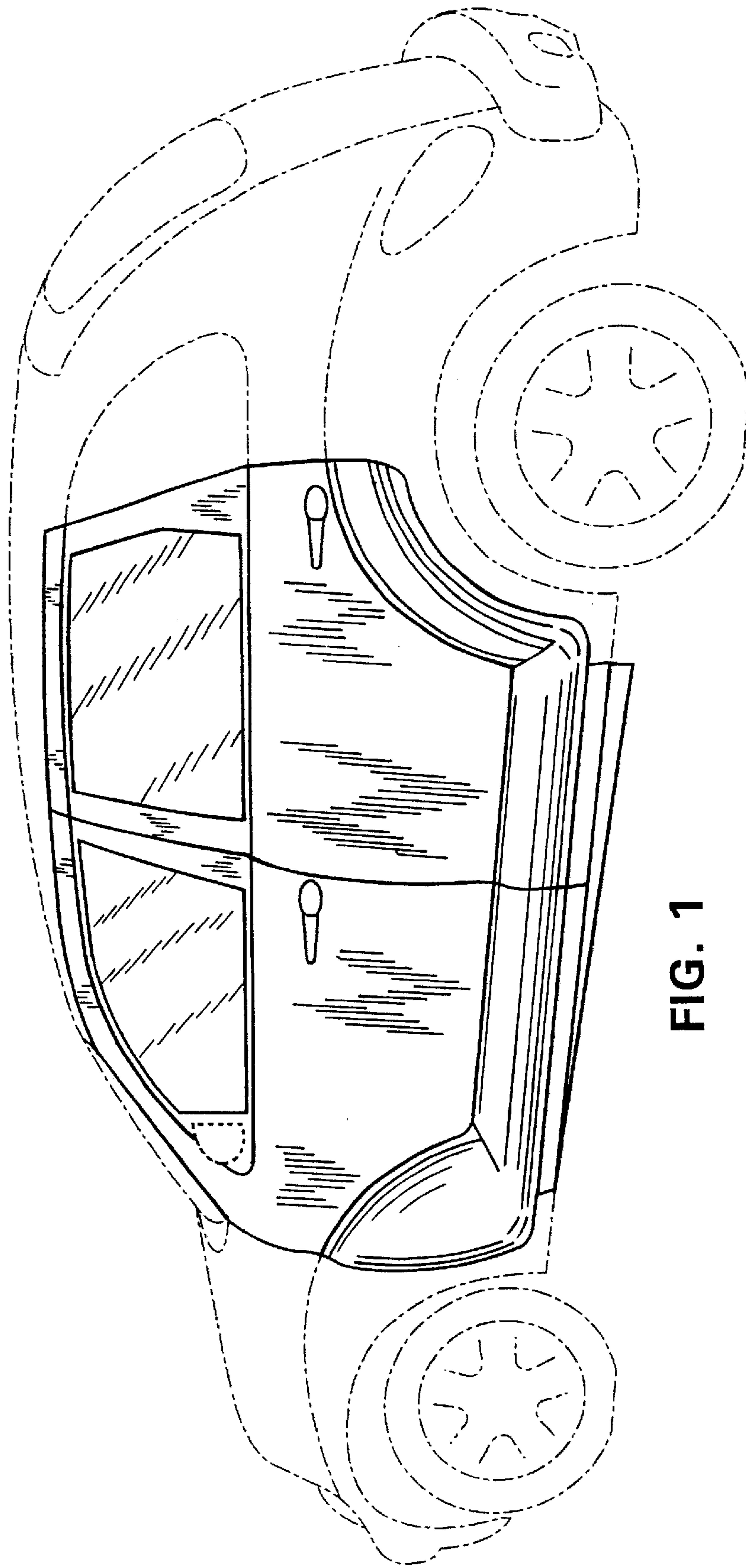

FIG. 1

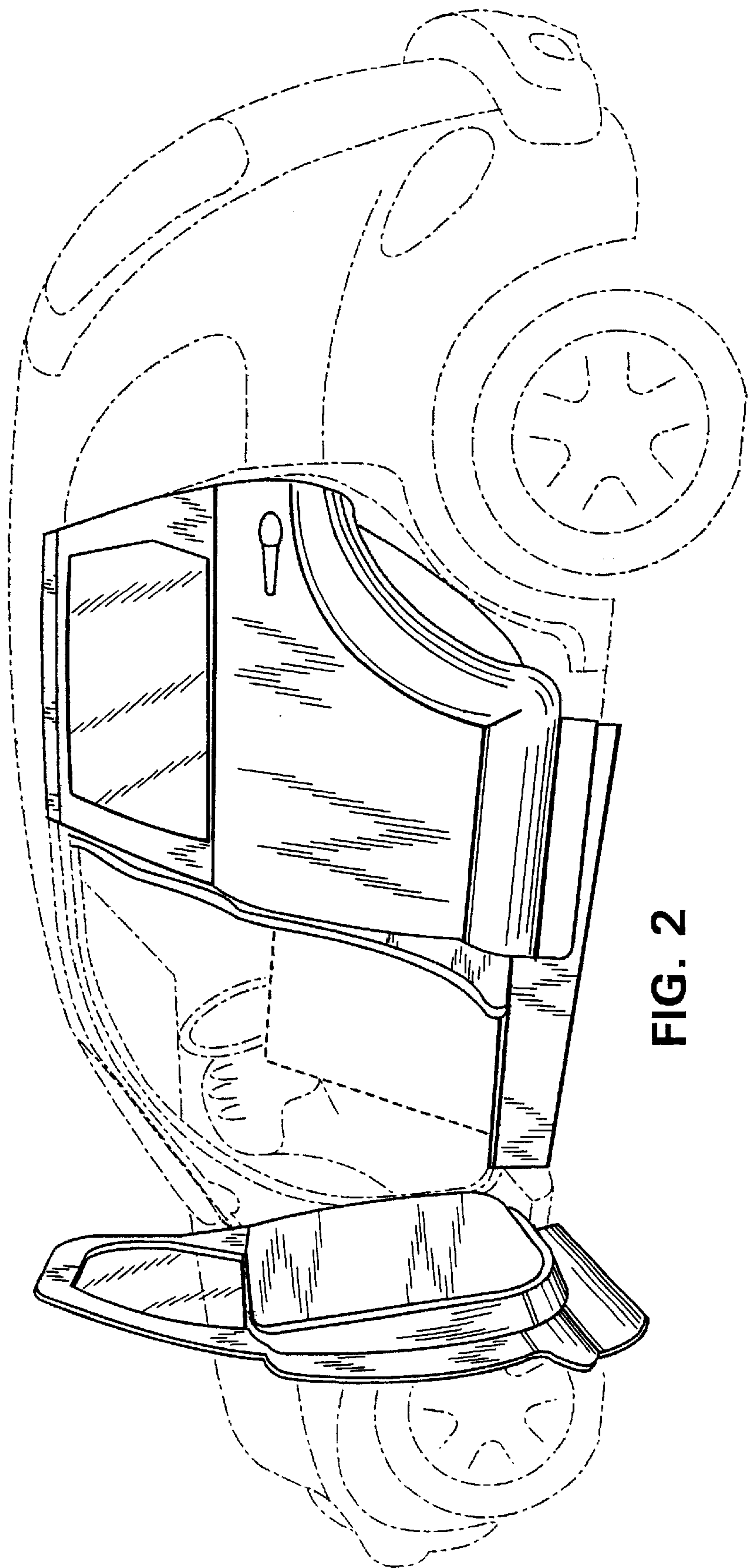

FIG. 2



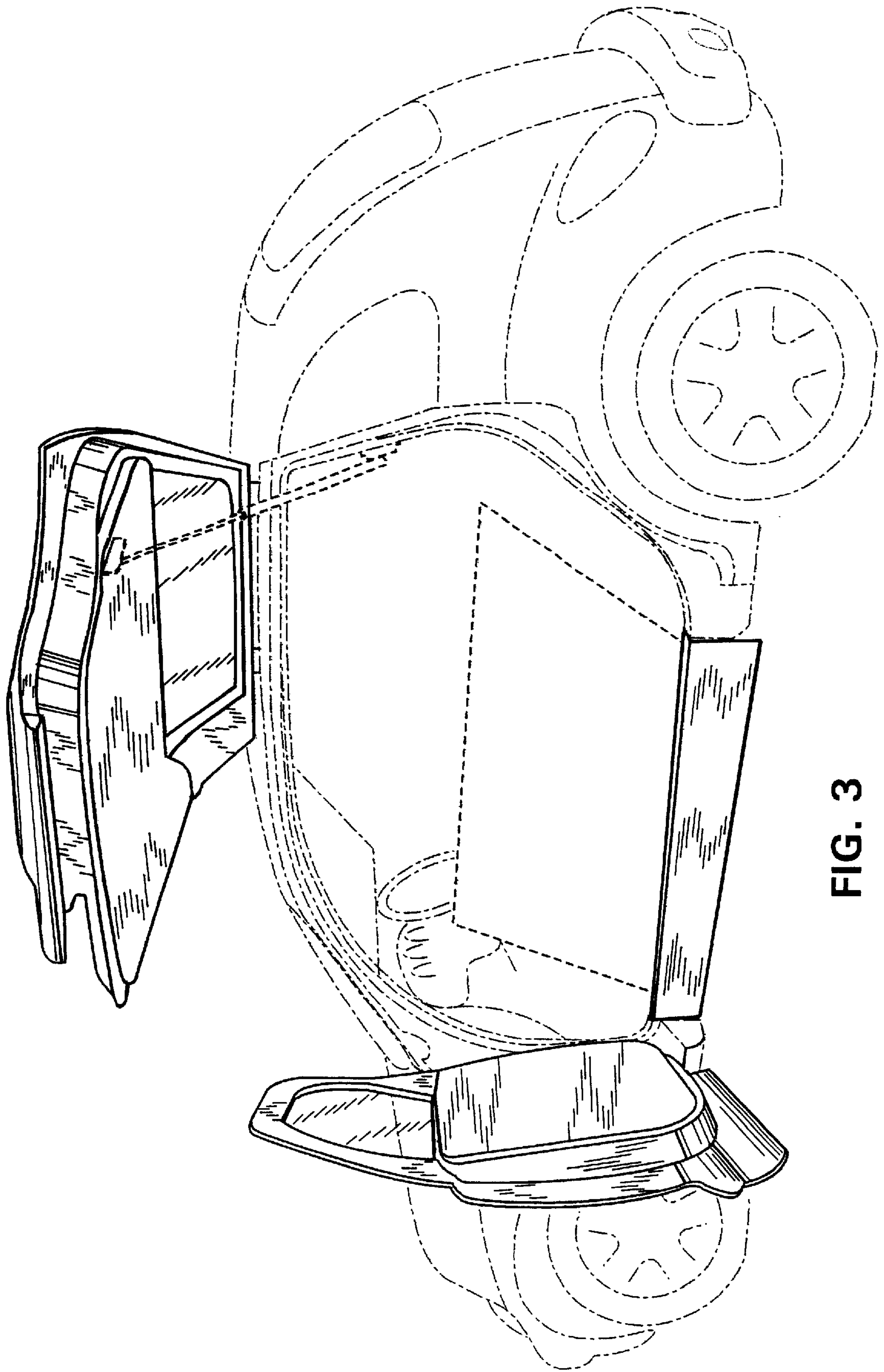

FIG. 3

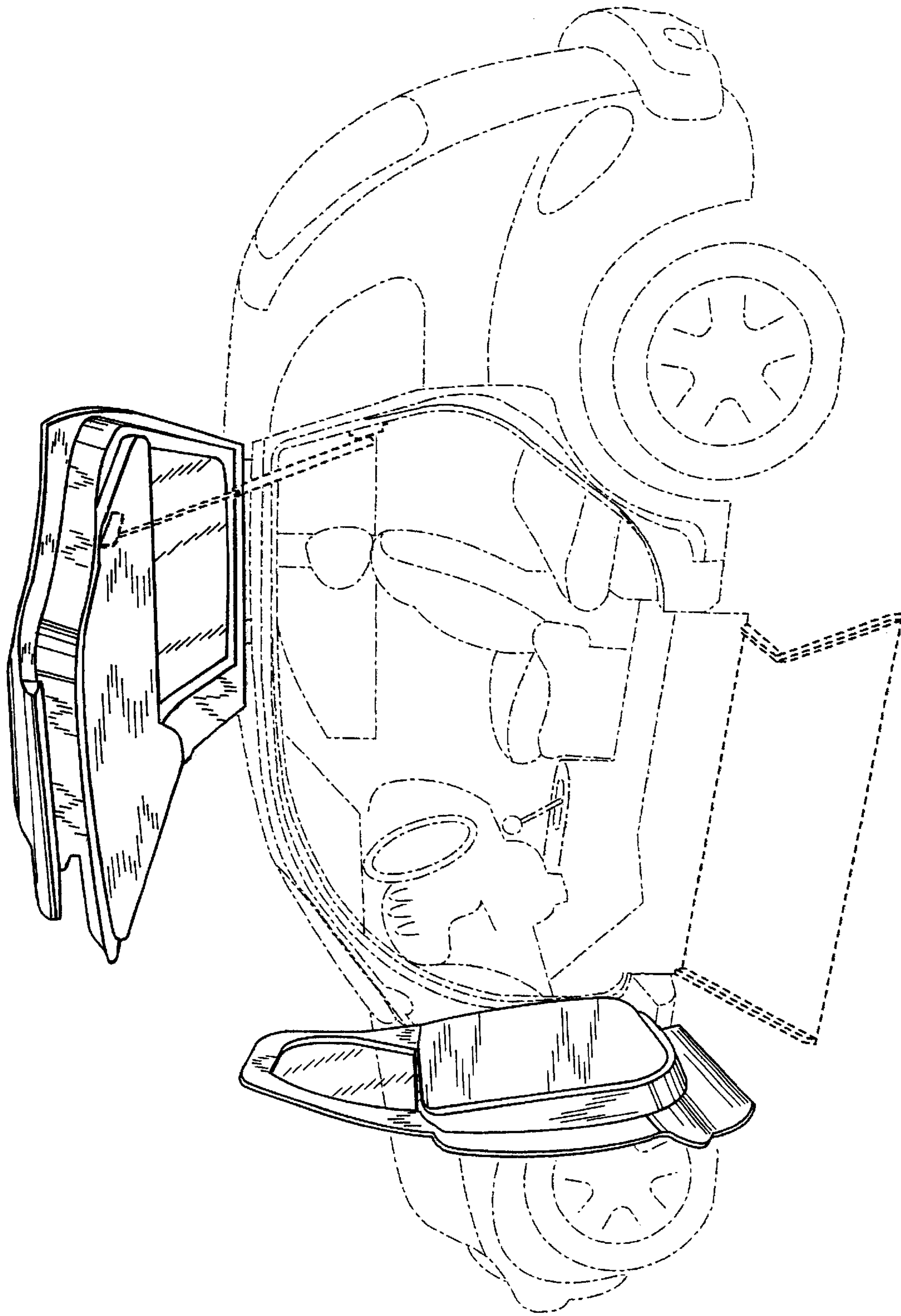

FIG. 4

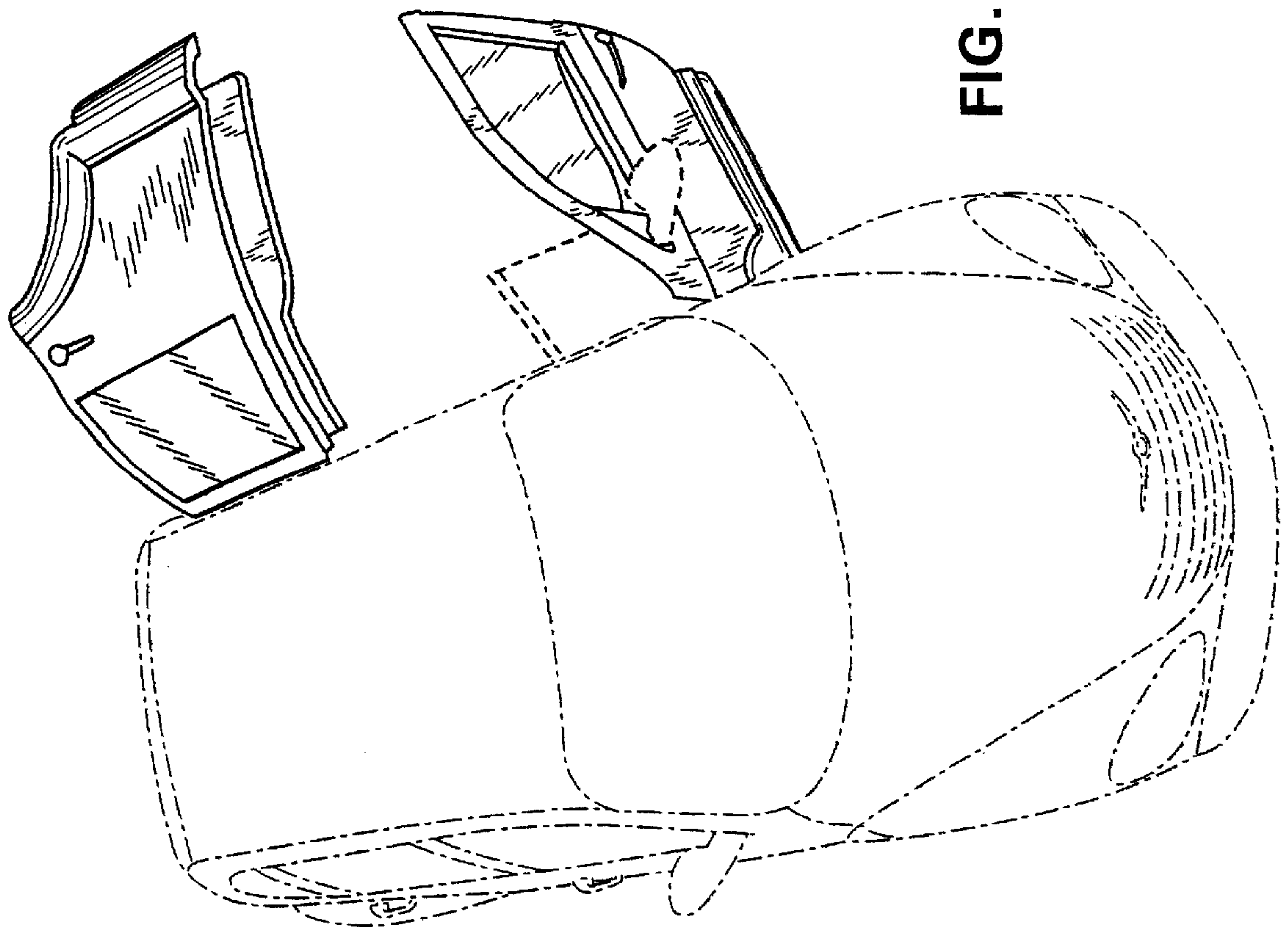

FIG. 5

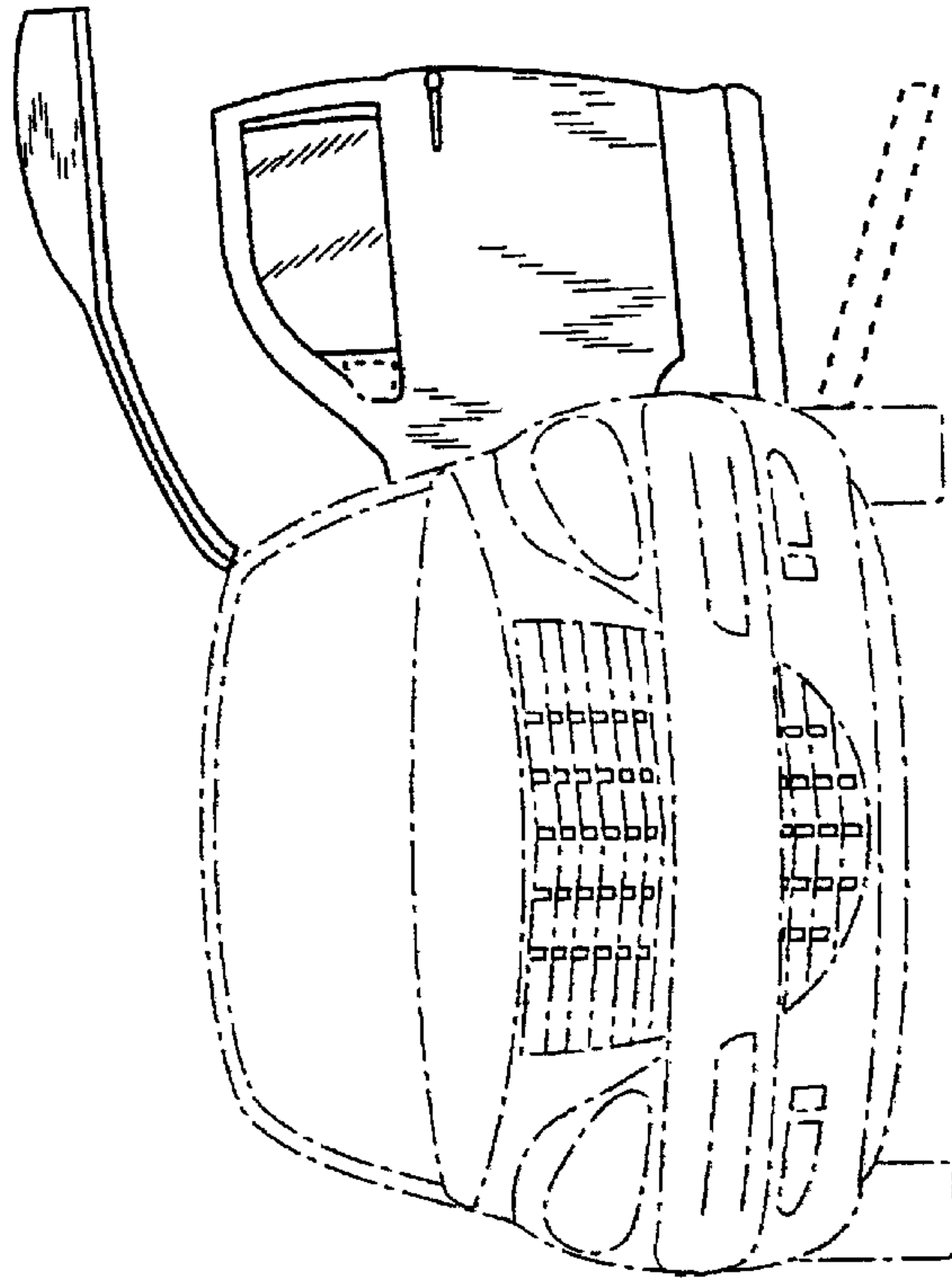

FIG. 7

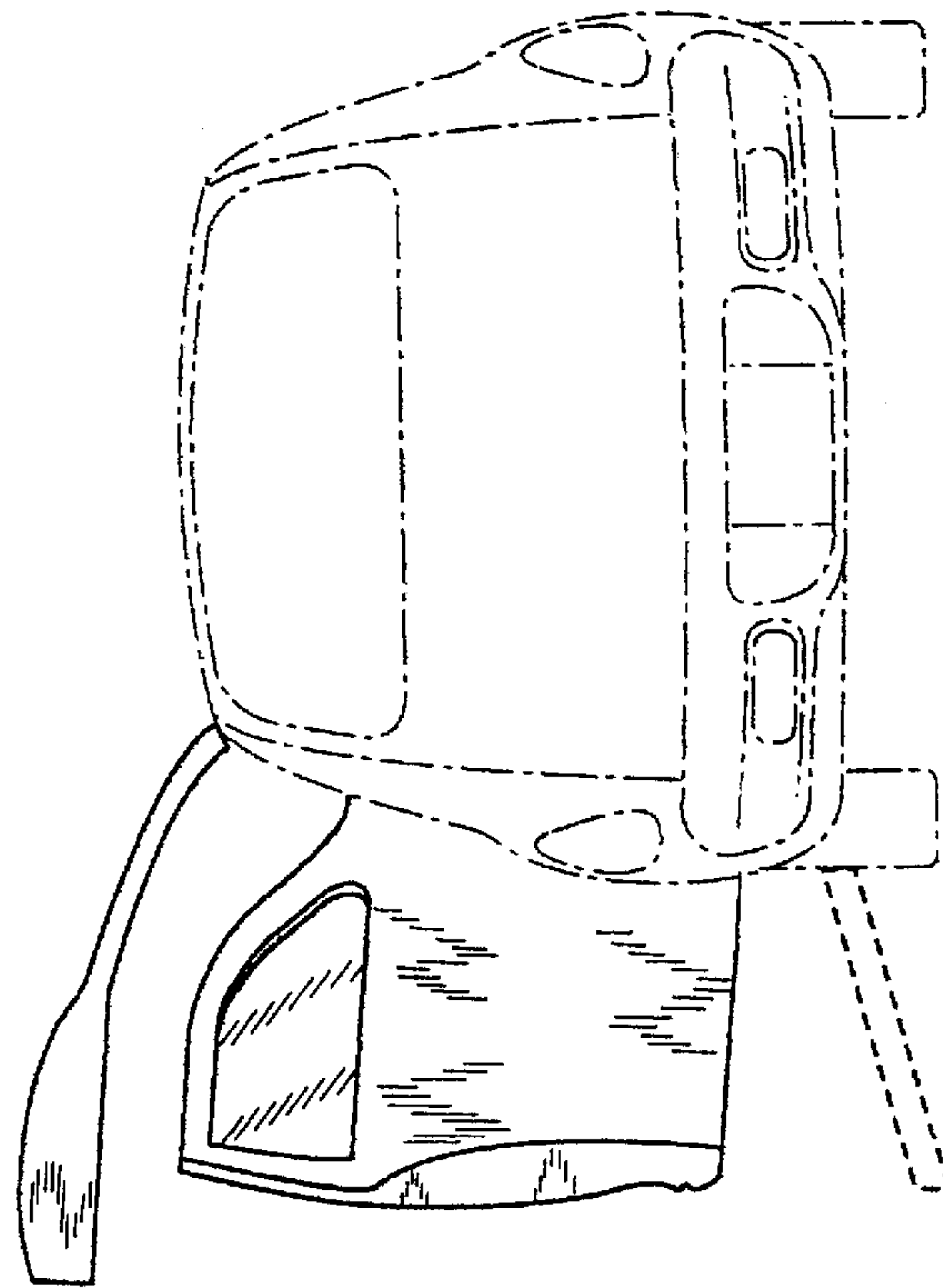

FIG. 6