



US00D468179S

(12) **United States Design Patent**
Hayakawa et al.

(10) **Patent No.:** **US D468,179 S**

(45) **Date of Patent:** **** Jan. 7, 2003**

(54) **PORTABLE ELECTRIC GRINDER**

(75) Inventors: **Naohiro Hayakawa, Anjo (JP);**
Fumitoshi Numata, Nagoya (JP)

(73) Assignee: **Makita Corporation, Aichi-ken (JP)**

(**) Term: **14 Years**

(21) Appl. No.: **29/153,790**

(22) Filed: **Jan. 11, 2002**

(30) **Foreign Application Priority Data**

Jul. 11, 2001 (JP) 2001-024132

(51) **LOC (7) Cl.** **08-01**

(52) **U.S. Cl.** **D8/62**

(58) **Field of Search** D8/61, 62; 173/170;
310/50; 451/344, 353, 356, 357, 358, 359,
451, 456, 490, 355

(56) **References Cited**

U.S. PATENT DOCUMENTS

D301,830 S * 6/1989 Ogawa et al. D8/62

D324,632 S * 3/1992 Nose et al. D8/61

D347,153 S * 5/1994 Uneyama D8/62

D408,244 S * 4/1999 Price D8/62

D437,199 S * 2/2001 Robson D8/62

* cited by examiner

Primary Examiner—Stacia Cadmus

Assistant Examiner—Elizabeth A. Albert

(74) *Attorney, Agent, or Firm*—Lahive & Cockfield, LLP

(57) **CLAIM**

The ornamental design for a portable electric grinder, as shown and described.

DESCRIPTION

FIG. 1 is a perspective view of a portable electric grinder showing my new design;

FIG. 2 is a front elevational view thereof;

FIG. 3 is a rear side elevational view thereof;

FIG. 4 is a left side elevational view thereof;

FIG. 5 is right side elevational view thereof;

FIG. 6 is a top plan view thereof; and,

FIG. 7 is a bottom plan view thereof;

1 Claim, 6 Drawing Sheets

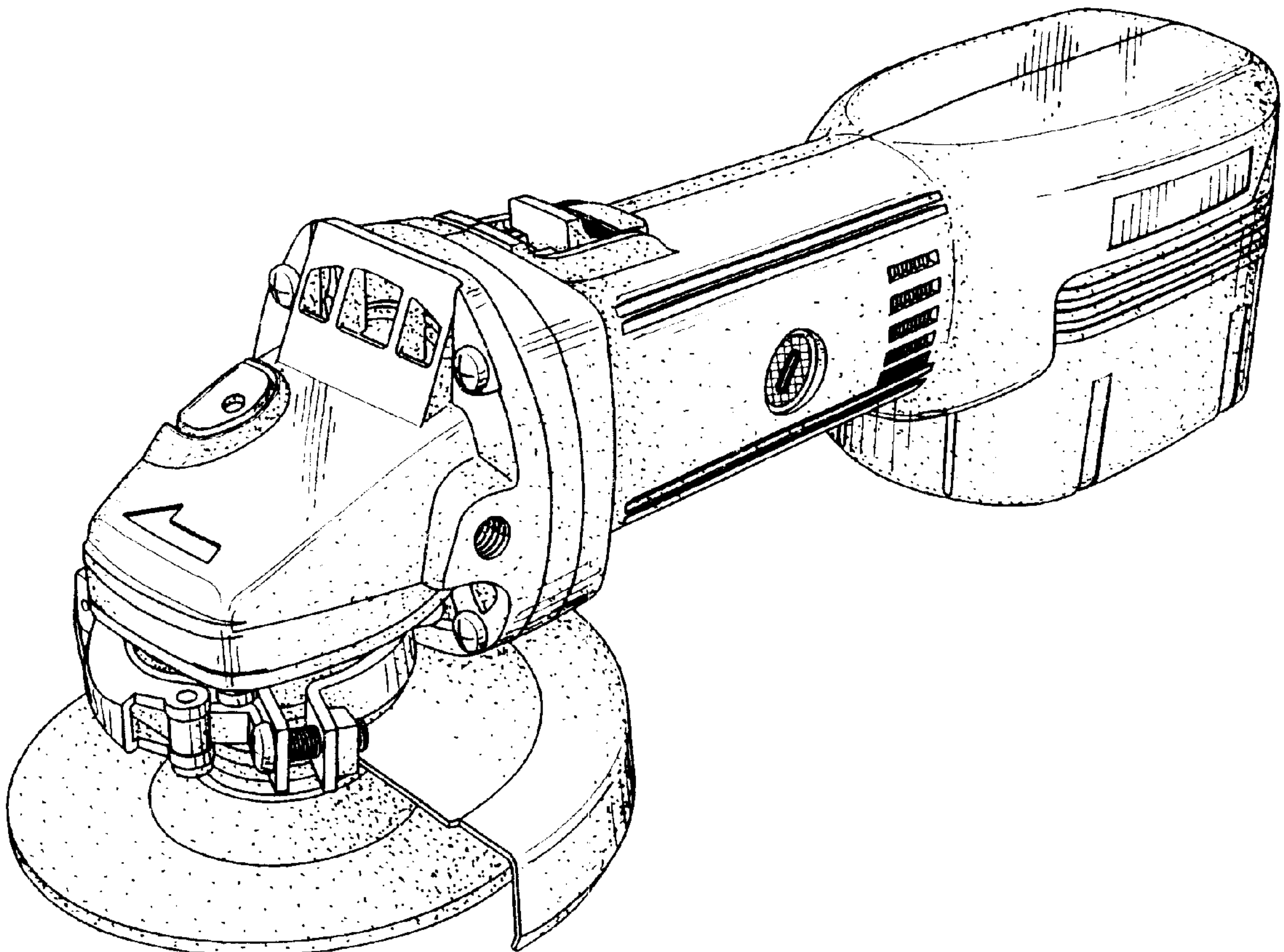

FIG. 1

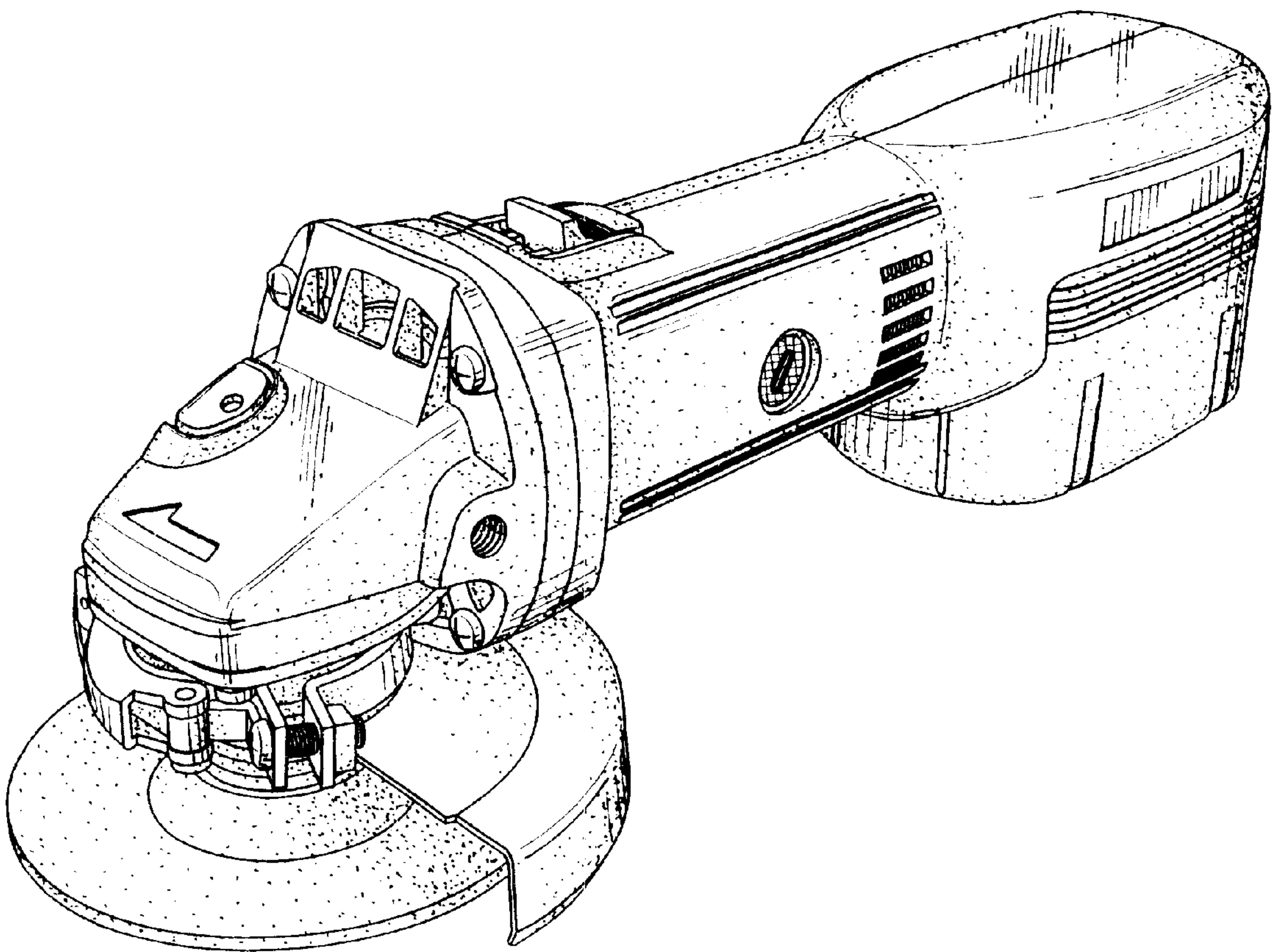

FIG. 2

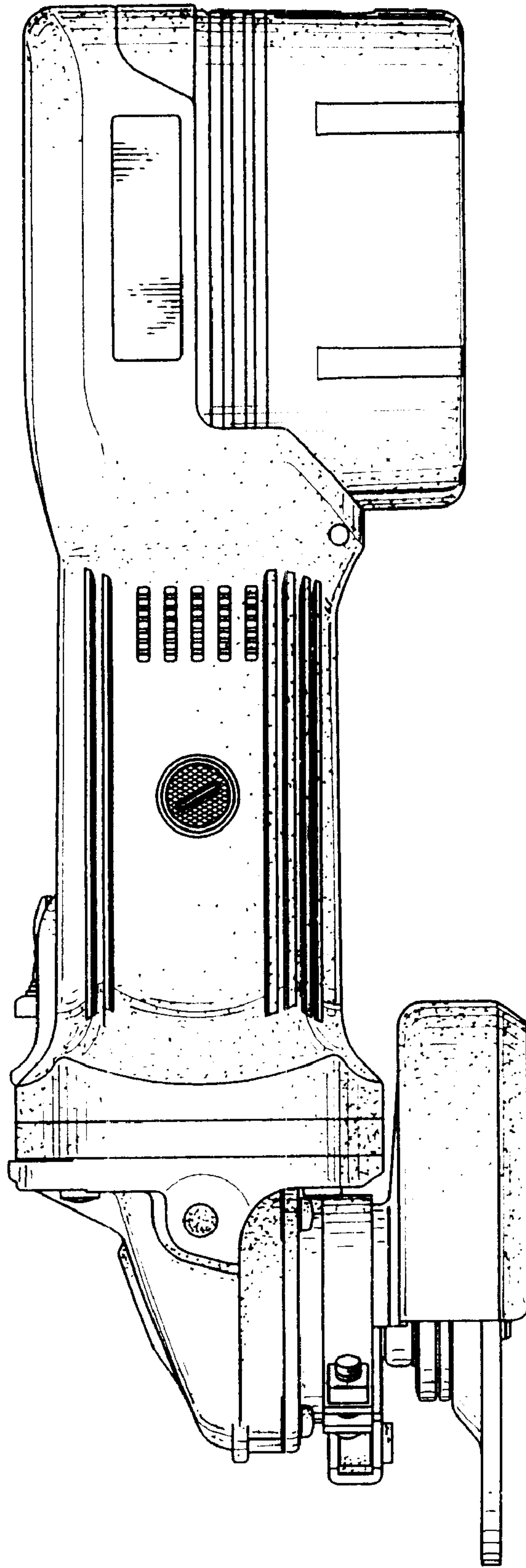

FIG. 3

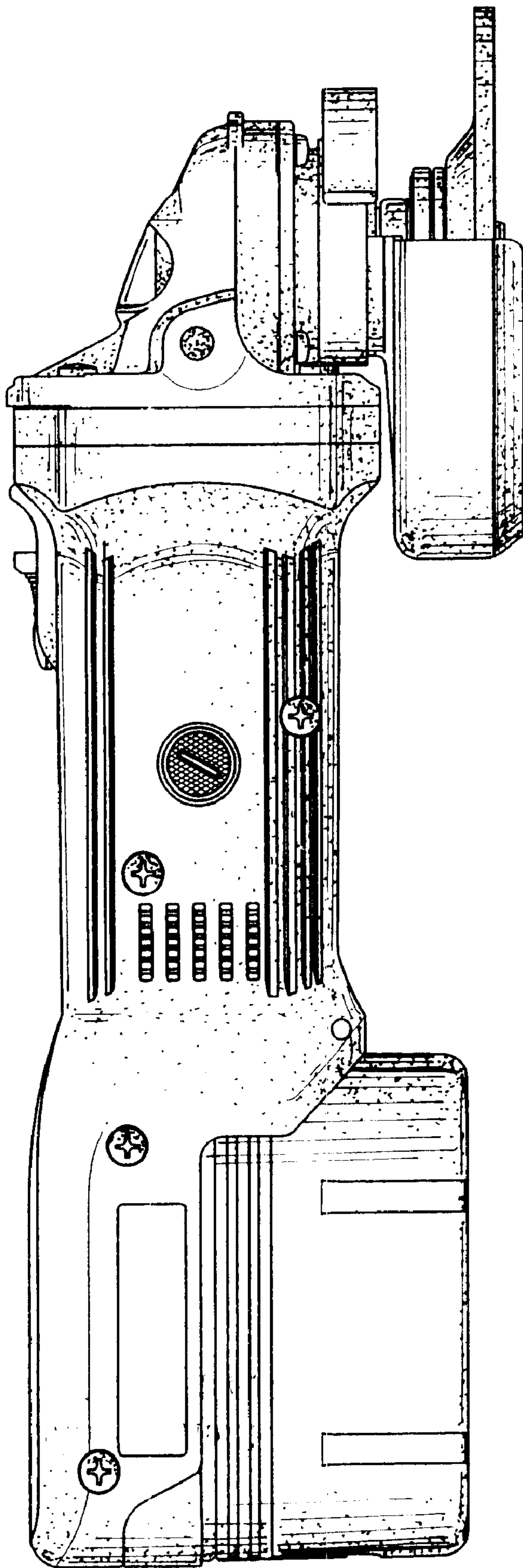

FIG. 4

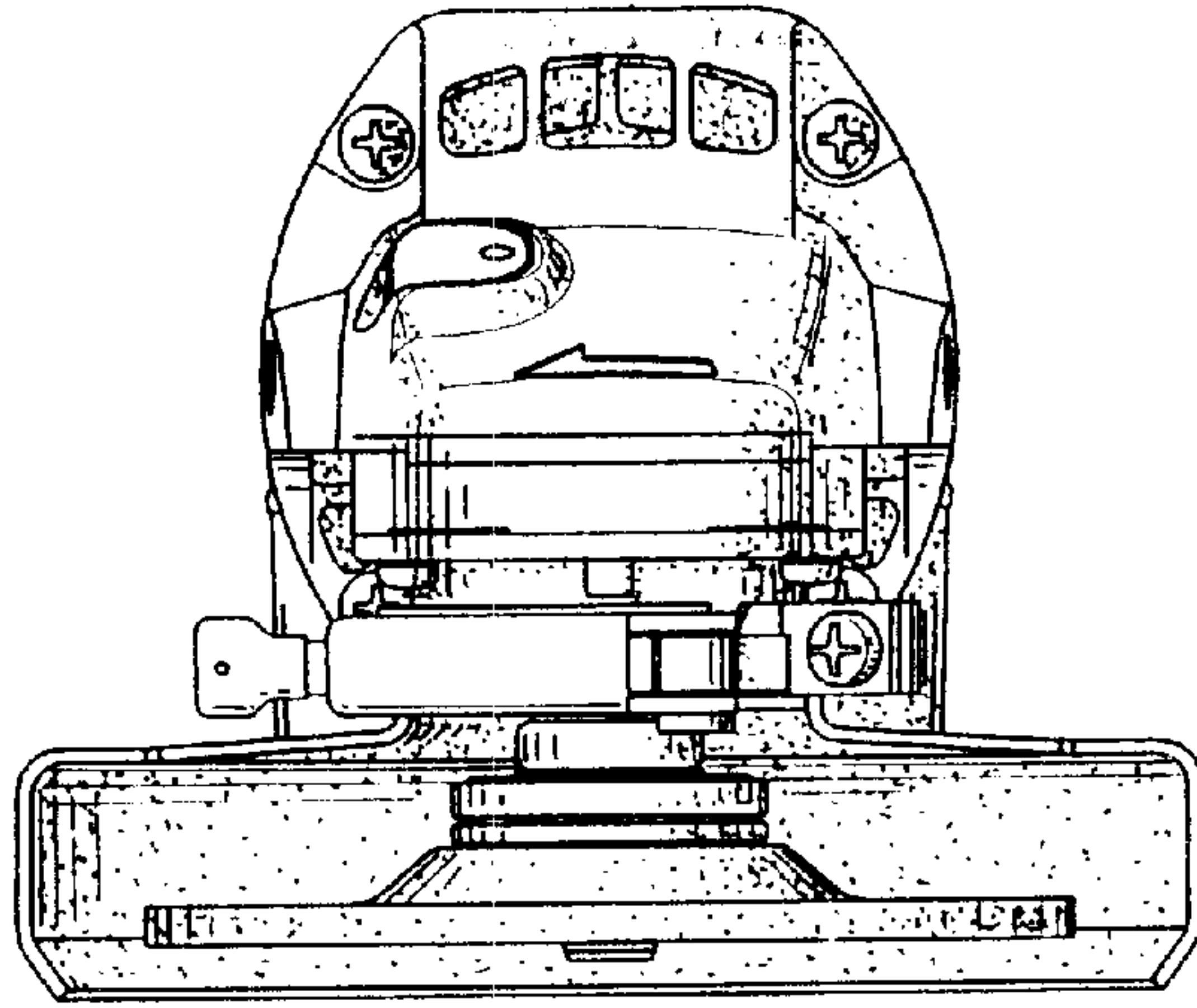

FIG. 5

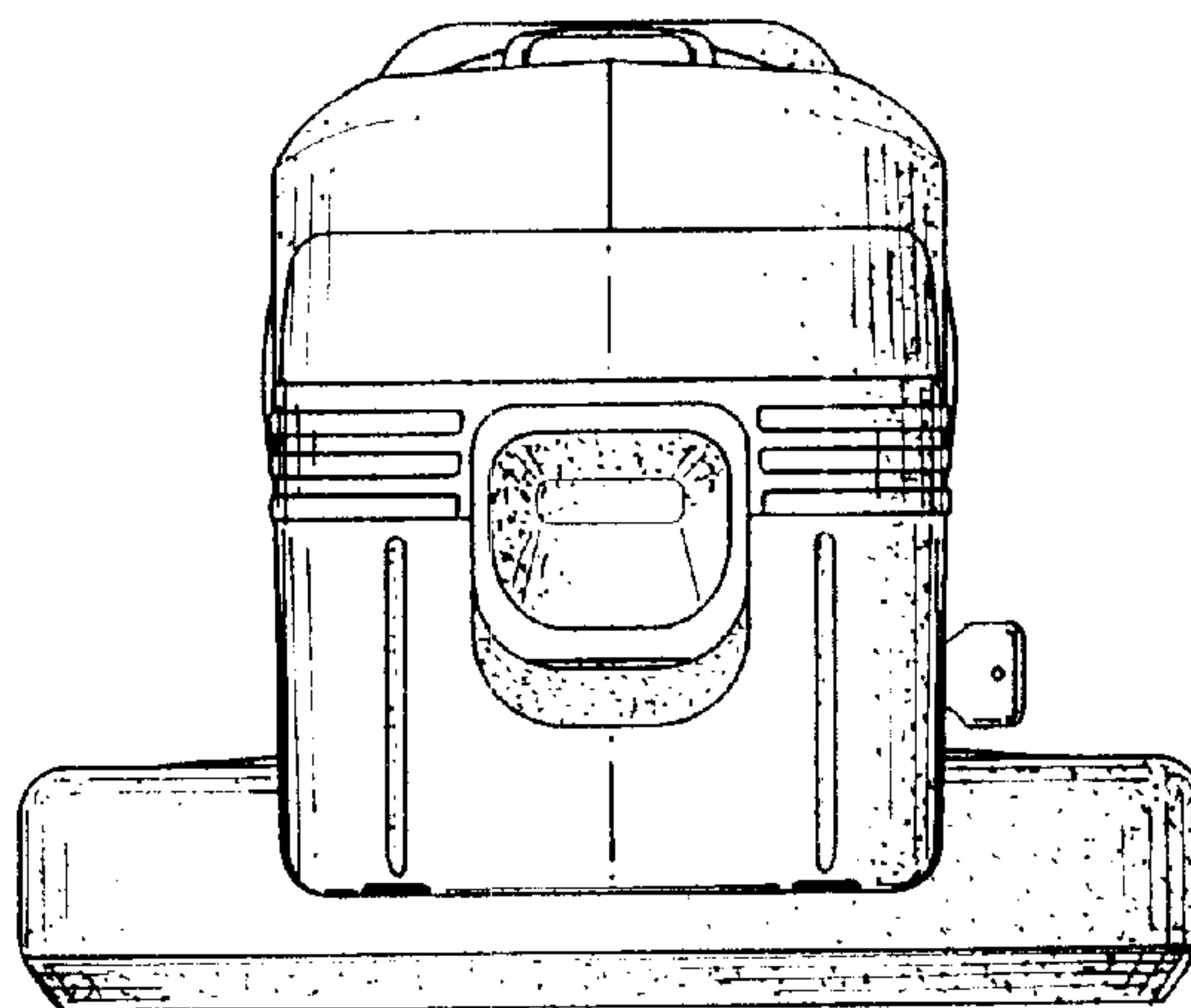

FIG. 6

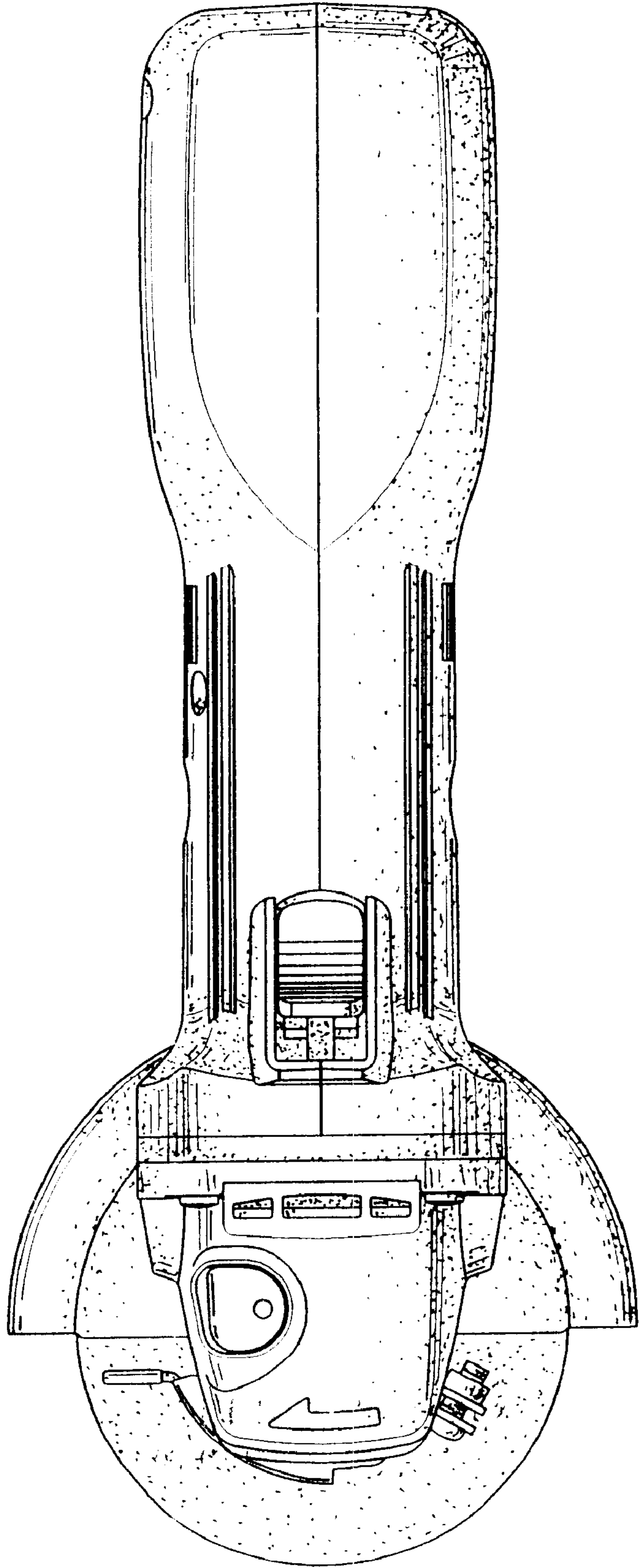

FIG. 7

