

US00D468036S

(12) **United States Design Patent**
Horowitz

(10) **Patent No.:** **US D468,036 S**

(45) **Date of Patent:** **** Dec. 31, 2002**

(54) **REPLACEMENT TAIL LENS ASSEMBLY**

D460,205 S * 7/2002 Horowitz D26/28
D460,833 S * 7/2002 Horowitz D26/28

(76) Inventor: **Brian A. Horowitz**, 252 Granite St.,
Corona, CA (US) 92879

OTHER PUBLICATIONS

(**) Term: **14 Years**

Photograph of rear ¾ view of 2000 Ford F-150 truck, prior to Jul. 25, 2001.

(21) Appl. No.: **29/159,563**

Advertisement—Stillen Sports Cars from Sport Compact Car, vol. 13, No. 03, Mar., 2001, pp. 58-59, prior to Jul. 25, 2001.

(22) Filed: **Apr. 23, 2002**

(List continued on next page.)

Related U.S. Application Data

(63) Continuation of application No. 29/145,574, filed on Jul. 25, 2001, now Pat. No. Des. 456,919.

Primary Examiner—Marcus A. Jackson

(51) **LOC (7) Cl.** **26-06**

(74) *Attorney, Agent, or Firm*—Knobbe, Martens, Olson & Bear LLP

(52) **U.S. Cl.** **D26/28**

(57) **CLAIM**

(58) **Field of Search** D26/28-36; 362/61, 362/80, 81, 82, 83, 83.4, 267, 269, 275

The ornamental design for a replacement tail lens assembly, as shown and described.

(56) **References Cited**

DESCRIPTION

U.S. PATENT DOCUMENTS

- D382,659 S 8/1997 Kaloustian
- D388,200 S 12/1997 Tomforde et al.
- D388,897 S 1/1998 Tomforde et al.
- D389,256 S 1/1998 Sacco et al.
- D396,310 S 7/1998 Sacco et al.
- D399,983 S 10/1998 Cadotte et al.
- D406,910 S 3/1999 Bangle
- D409,772 S 5/1999 Bangle
- D412,214 S 7/1999 Hejtmanek
- D412,587 S 8/1999 Bangle
- D413,400 S 8/1999 Bangle
- D416,638 S 11/1999 Horbury et al.
- D427,363 S 6/2000 Sacco et al.
- D429,353 S 8/2000 Pfeiffer
- D439,995 S 4/2001 Nakazawa et al.
- D440,331 S 4/2001 Nakazawa et al.
- 6,243,008 B1 6/2001 Korabiak
- D449,898 S 10/2001 Horowitz
- 6,296,382 B1 10/2001 Hamelbeck
- D456,919 S * 5/2002 Horowitz D26/28

FIG. 1 is a right-side perspective view of the replacement tail lens assembly of the present design;
 FIG. 2 is a right-side perspective view of the replacement tail lens assembly of FIG. 1, showing the cover of the tail lens assembly removed;
 FIG. 3 is a front elevational view of the replacement tail lens assembly of FIG. 1;
 FIG. 4 is a right side elevational view of the replacement tail lens assembly of FIG. 1;
 FIG. 5 is a top plan view of the replacement tail lens assembly of FIG. 1; and,
 FIG. 6 is a right-side perspective view of the replacement tail lens assembly of FIG. 1, showing the tail lens assembly installed on a vehicle.
 Phantom lining, where used, is for illustrative purposes only and is not intended to limit the claimed design to the features shown in phantom.

1 Claim, 4 Drawing Sheets

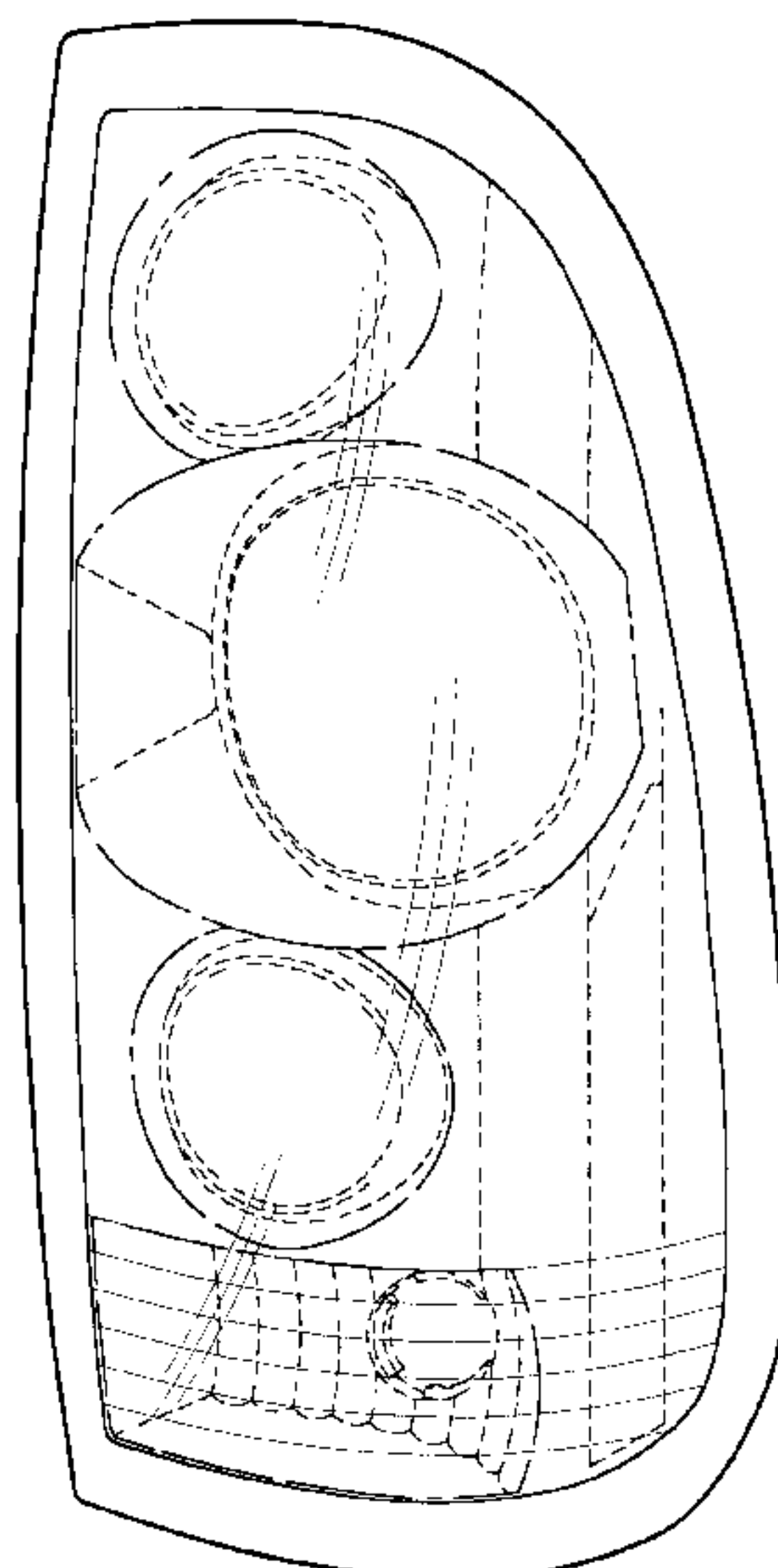

OTHER PUBLICATIONS

Three photographs of rear view of Chevy S-10 truck, prior to Jul. 25, 2001.

Three photographs of rear view of Acura Integra automobile, prior to Jul. 25, 2001.

Three photographs of rear view of Dodge Neon automobile, prior to Jul. 25, 2001.

Three photographs of rear view of Honda Accord automobile, prior to Jul. 25, 2001.

Three photographs of rear view of Honda Civic automobile, prior to Jul. 25, 2001.

Three photographs of rear view of Chevrolet C/K truck, prior to Jul. 25, 2001.

American Products Company 2001 Catalog, pp. 10-13, published Oct. 10, 2000.

Promotional material from Sigma Polyurethane International, prior to Jul. 25, 2001.

Toucan Industries, Inc. 2001 Catalog, p. 25, prior to Oct. 30, 2000.

* cited by examiner

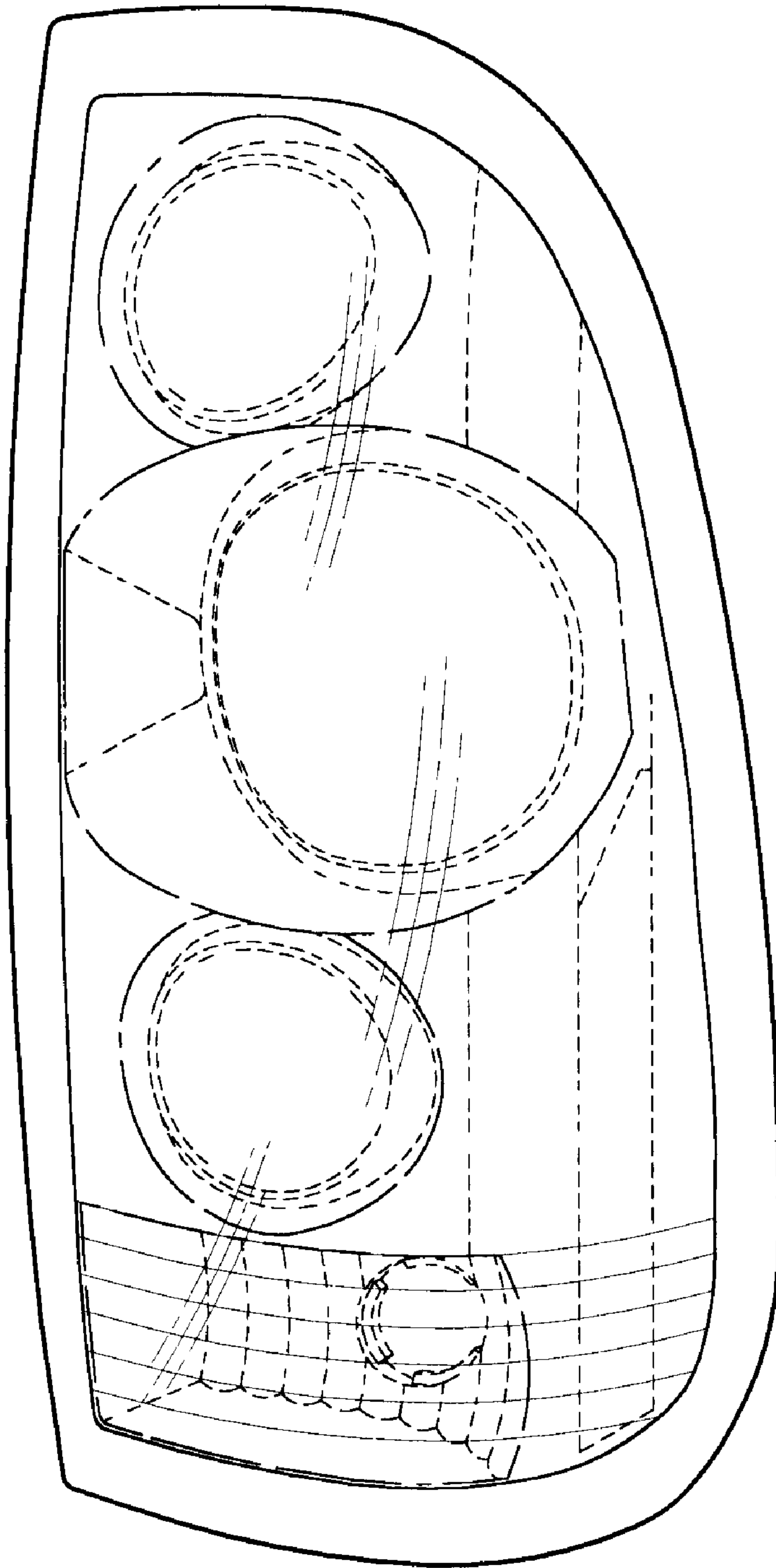

FIG. 1

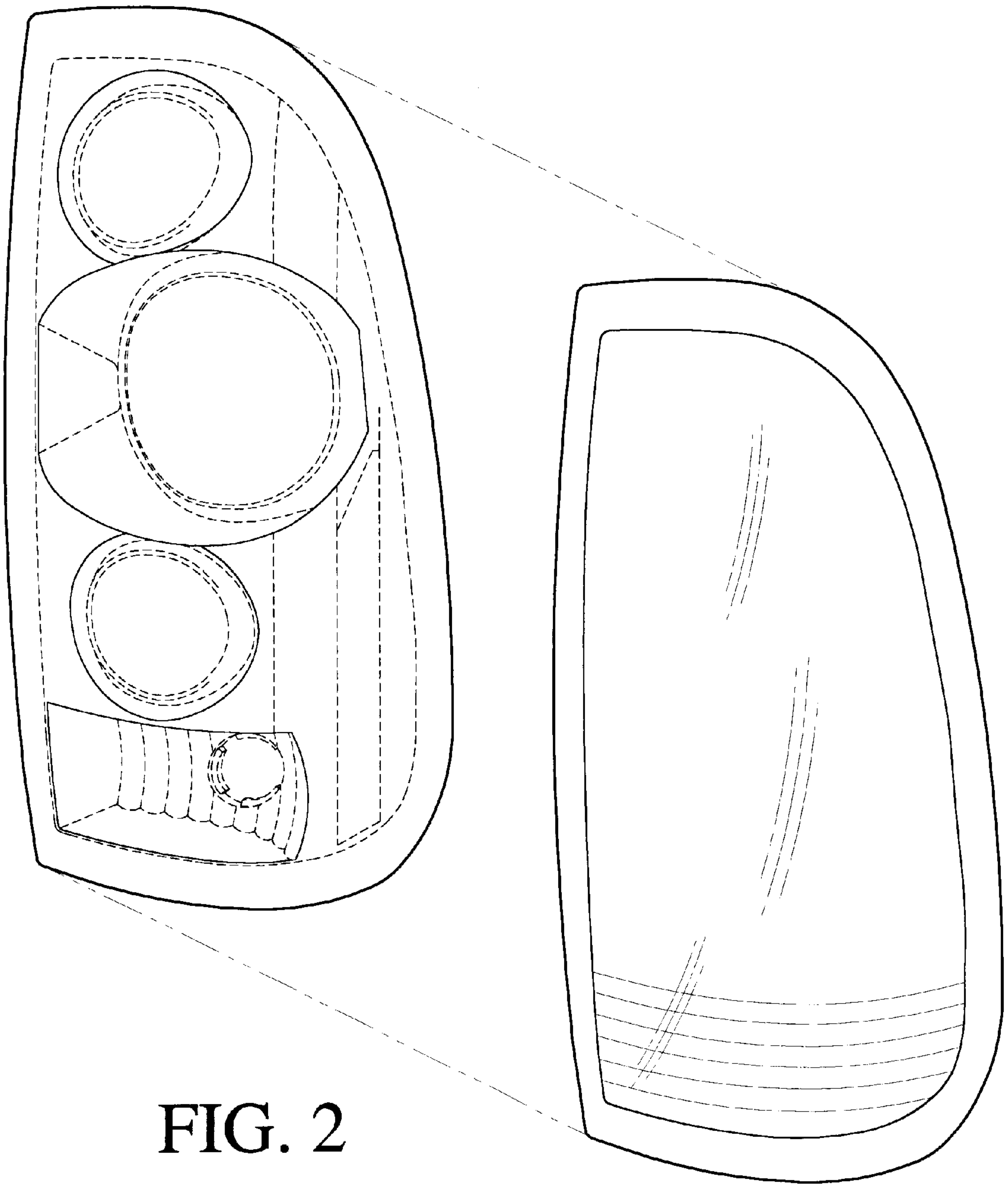

FIG. 2

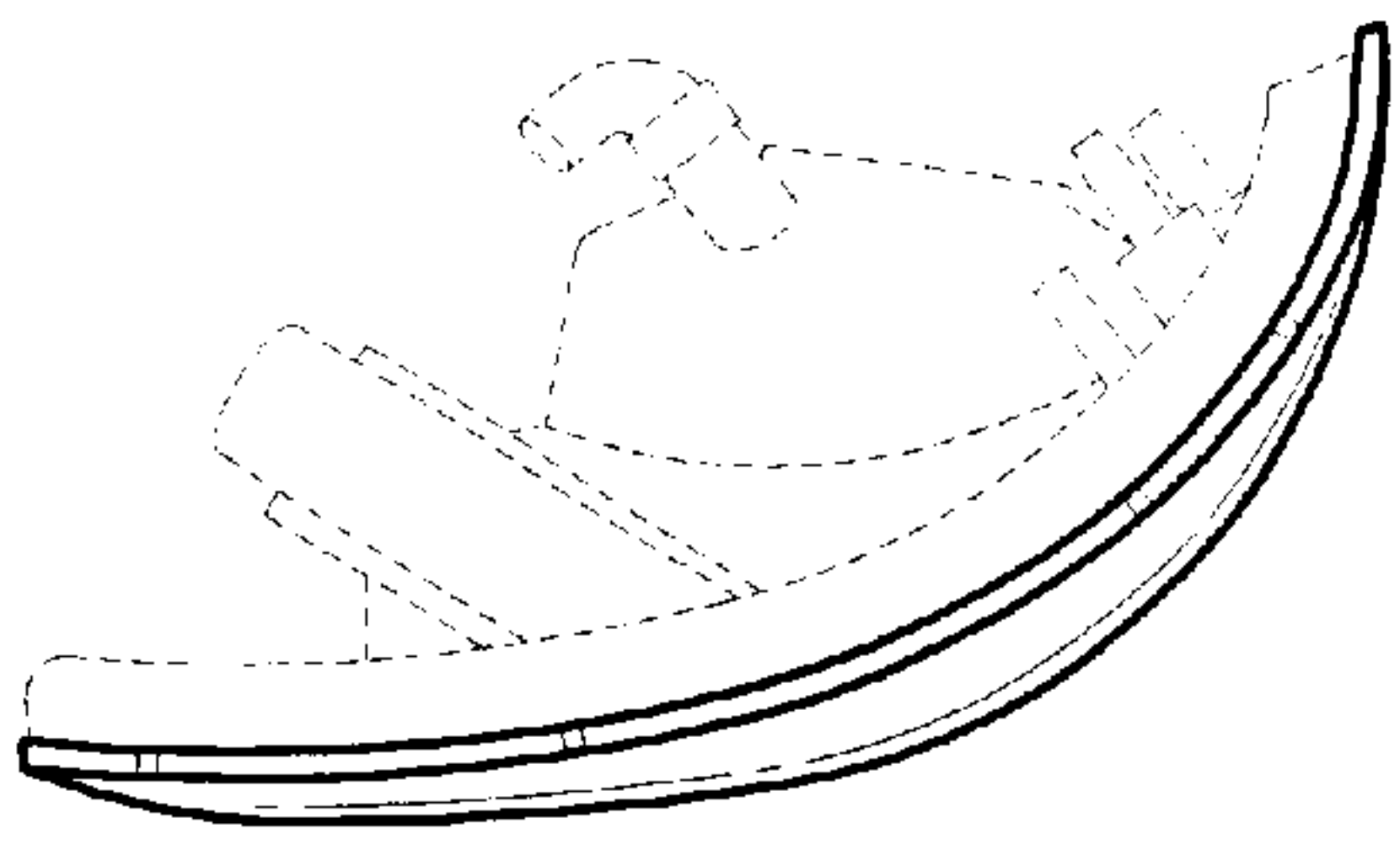

FIG. 5

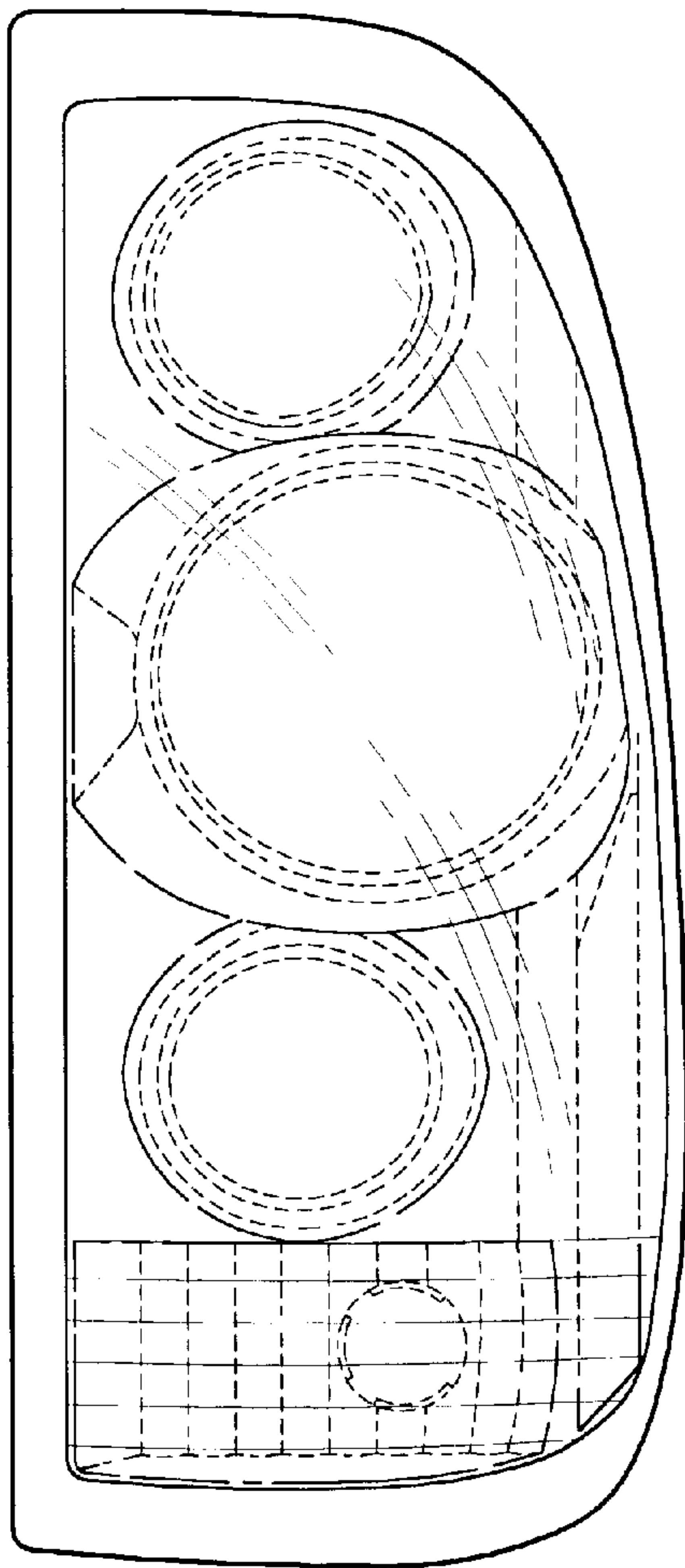

FIG. 3

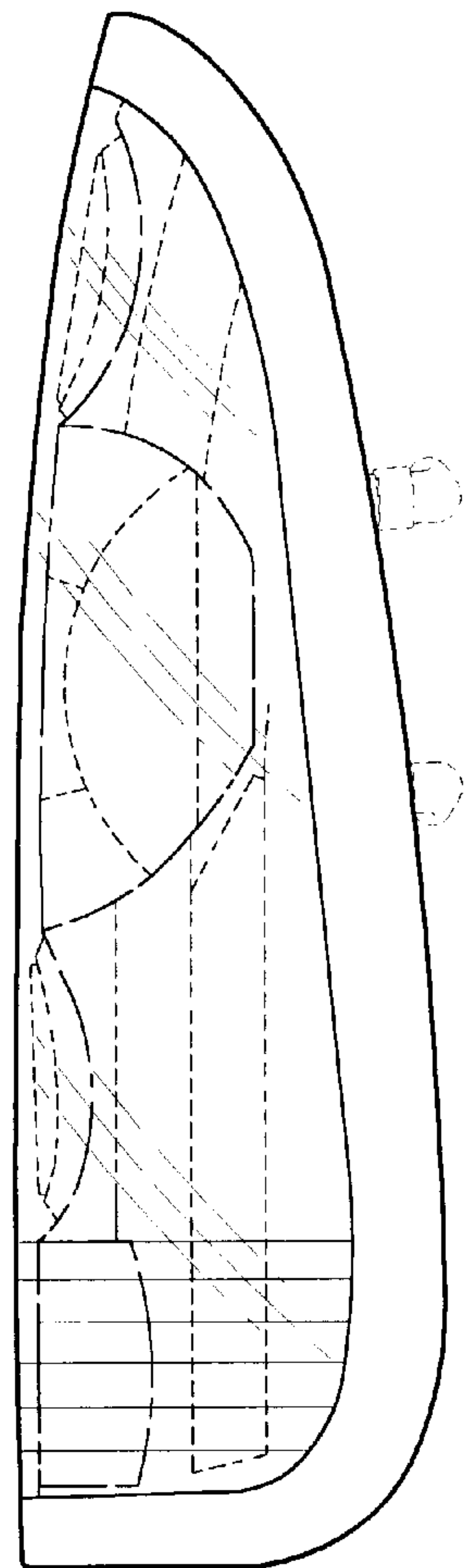

FIG. 4

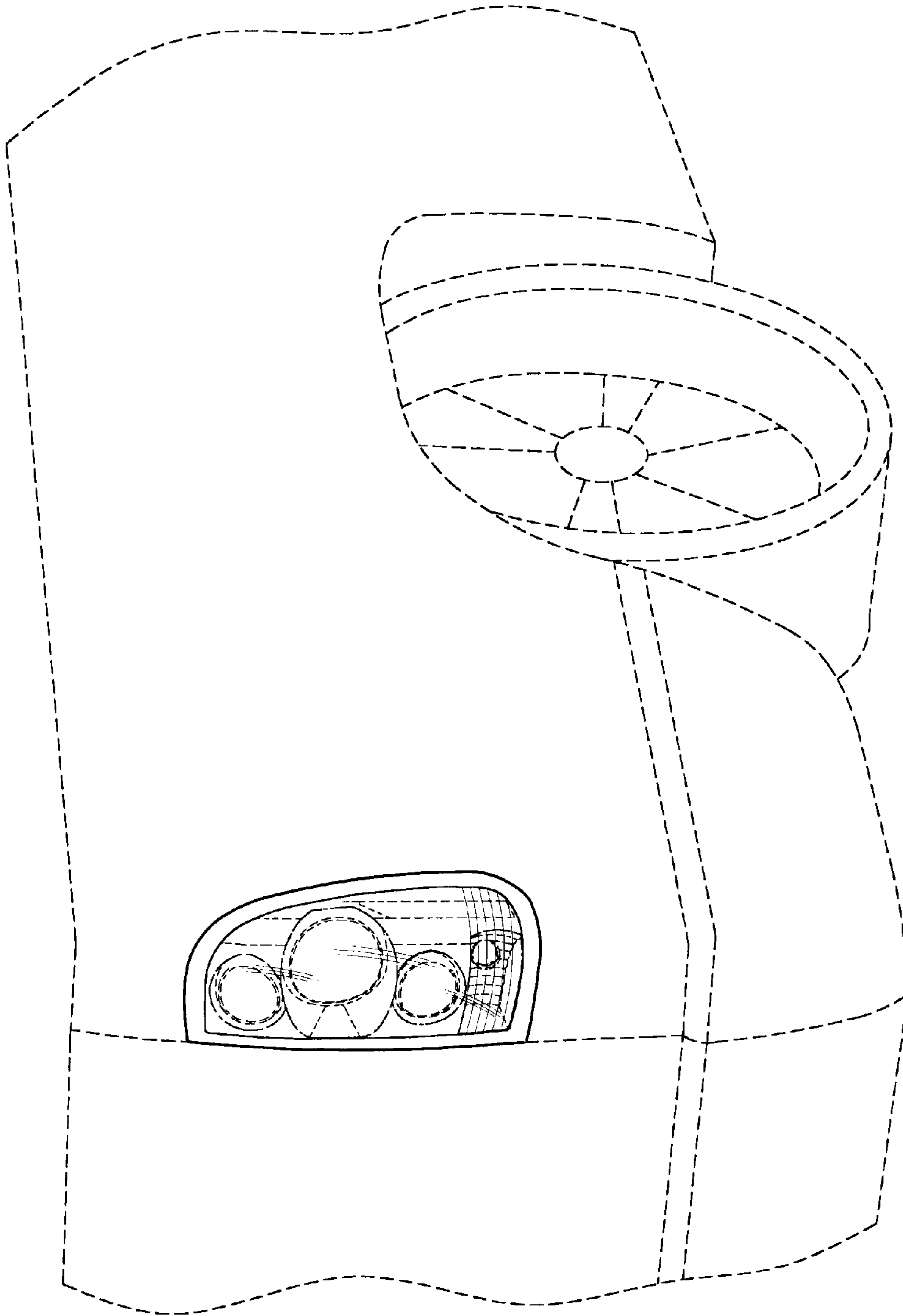

FIG. 6