



US00D467855S

(12) **United States Design Patent**
Laengerer

(10) **Patent No.:** **US D467,855 S**

(45) **Date of Patent:** **** Dec. 31, 2002**

(54) **FRONT FACE OF A VEHICLE WHEEL**

(75) Inventor: **Marcus Laengerer**, Renningen (DE)

(73) Assignee: **DaimlerChrysler AG**, Stuttgart (DE)

(**) Term: **14 Years**

(21) Appl. No.: **29/144,670**

(22) Filed: **Jul. 10, 2001**

(30) **Foreign Application Priority Data**

Jan. 11, 2001 (DE) 4 01 00 131

(51) **LOC (7) Cl.** **12-16**

(52) **U.S. Cl.** **D12/209**

(58) **Field of Search** D12/204-211;
301/37.101, 64.101, 65

(56) **References Cited**

U.S. PATENT DOCUMENTS

- D267,564 S * 1/1983 Wright D12/211
- D361,547 S * 8/1995 Weld D12/211
- D379,612 S * 6/1997 Honarkhah D12/209
- D380,432 S * 7/1997 Hettler D12/209
- D384,025 S * 9/1997 Roesianto D12/209
- D384,320 S * 9/1997 Bhambra D12/209
- D398,573 S * 9/1998 Cattaneo D12/211
- D403,289 S * 12/1998 Watanabe D12/209
- D407,052 S * 3/1999 Kelley D12/209
- D407,364 S * 3/1999 Fisker D12/209
- D408,343 S * 4/1999 Sacco et al. D12/209
- D412,692 S * 8/1999 Hussaini D12/209
- D421,417 S * 3/2000 Weidhase D12/209
- D422,258 S * 4/2000 Hale, Jr. D12/211
- D428,846 S * 8/2000 Yoshida et al. D12/211
- D432,974 S * 10/2000 Jablonski D12/211
- D433,374 S * 11/2000 Wang D12/209
- D433,659 S * 11/2000 Frizzi D12/211
- D437,819 S * 2/2001 Brown et al. D12/209

- D437,821 S * 2/2001 Frohlich D12/211
- D438,505 S * 3/2001 McMath D12/211
- D447,727 S * 9/2001 Laengerer D12/209
- D449,028 S * 10/2001 Weidhase D12/209
- D450,647 S * 11/2001 Pfeiffer D12/211
- D450,650 S * 11/2001 Cinibulk D12/211
- D452,839 S * 1/2002 Muth et al. D12/209
- D454,105 S * 3/2002 Pfeiffer D12/209
- D454,527 S * 3/2002 Bhambra D12/209
- D455,993 S * 4/2002 Ayoub et al. D12/211
- D456,333 S * 4/2002 Pollmann D12/211
- D457,478 S * 5/2002 Minamisawa D12/211
- D458,204 S * 6/2002 Kataoka D12/209
- D458,571 S * 6/2002 Maifrini D12/209
- D458,572 S * 6/2002 Fitzgerald D12/209
- D458,887 S * 6/2002 Kataoka D12/209
- D459,689 S * 7/2002 Hieke D12/211
- D460,037 S * 7/2002 Takechi D12/211

* cited by examiner

Primary Examiner—Stacia Cadmus

(74) *Attorney, Agent, or Firm*—Crowell & Moring LLP

(57) **CLAIM**

The ornamental design for a front face of a vehicle wheel, as shown and described.

DESCRIPTION

FIG. 1 is a front view of a first embodiment of a front face of a vehicle wheel according to my novel design; FIG. 2 is a perspective view of the first embodiment of the front face of a vehicle wheel according to my novel design; FIG. 3 is a front view of a second embodiment of the front face of a vehicle wheel according to my novel design; and, FIG. 4 is a perspective view of the second embodiment of the front face of a vehicle wheel according to my novel design.

The dash lines included depict environment and are not part of the claimed design.

1 Claim, 2 Drawing Sheets

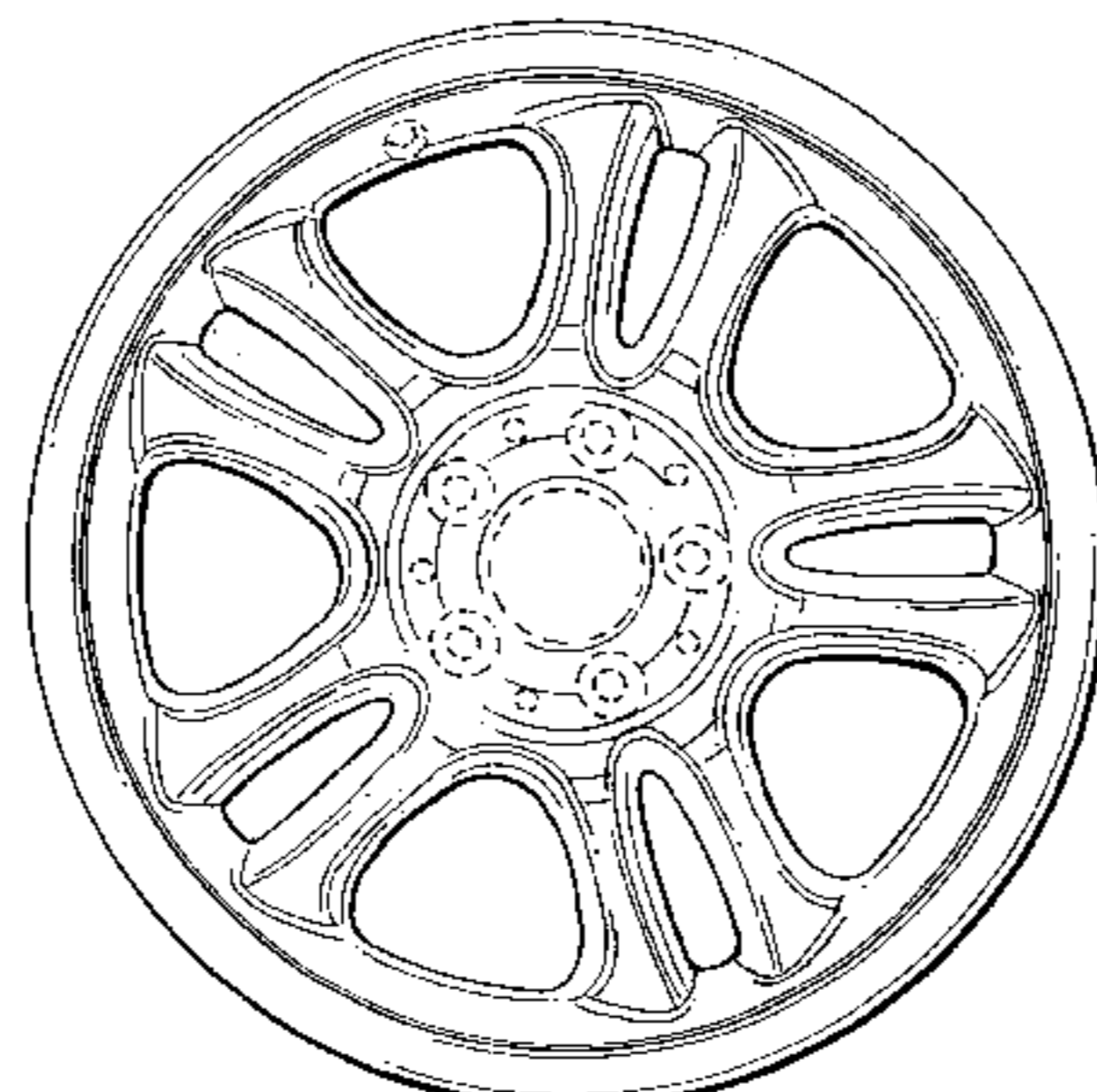
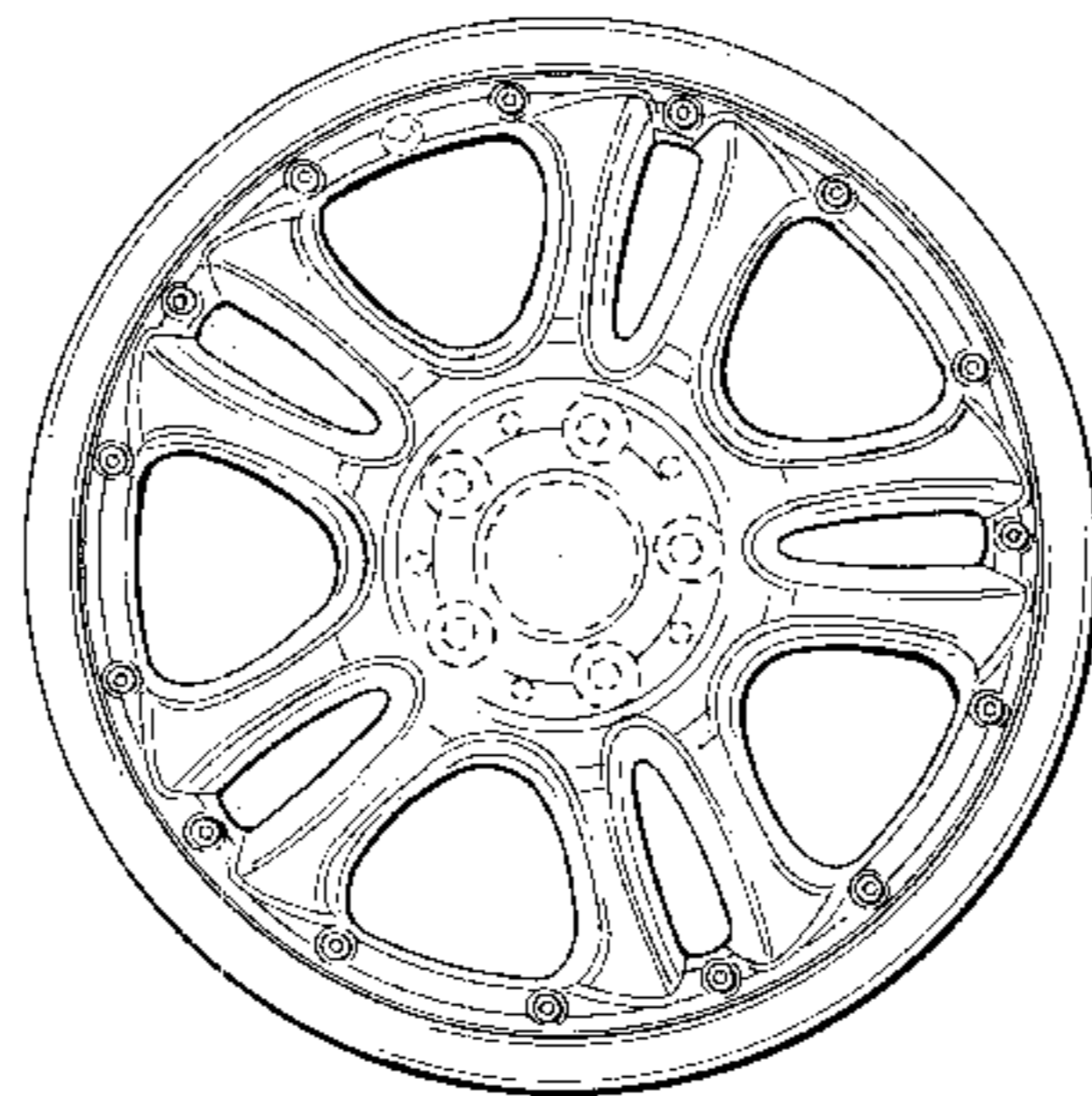

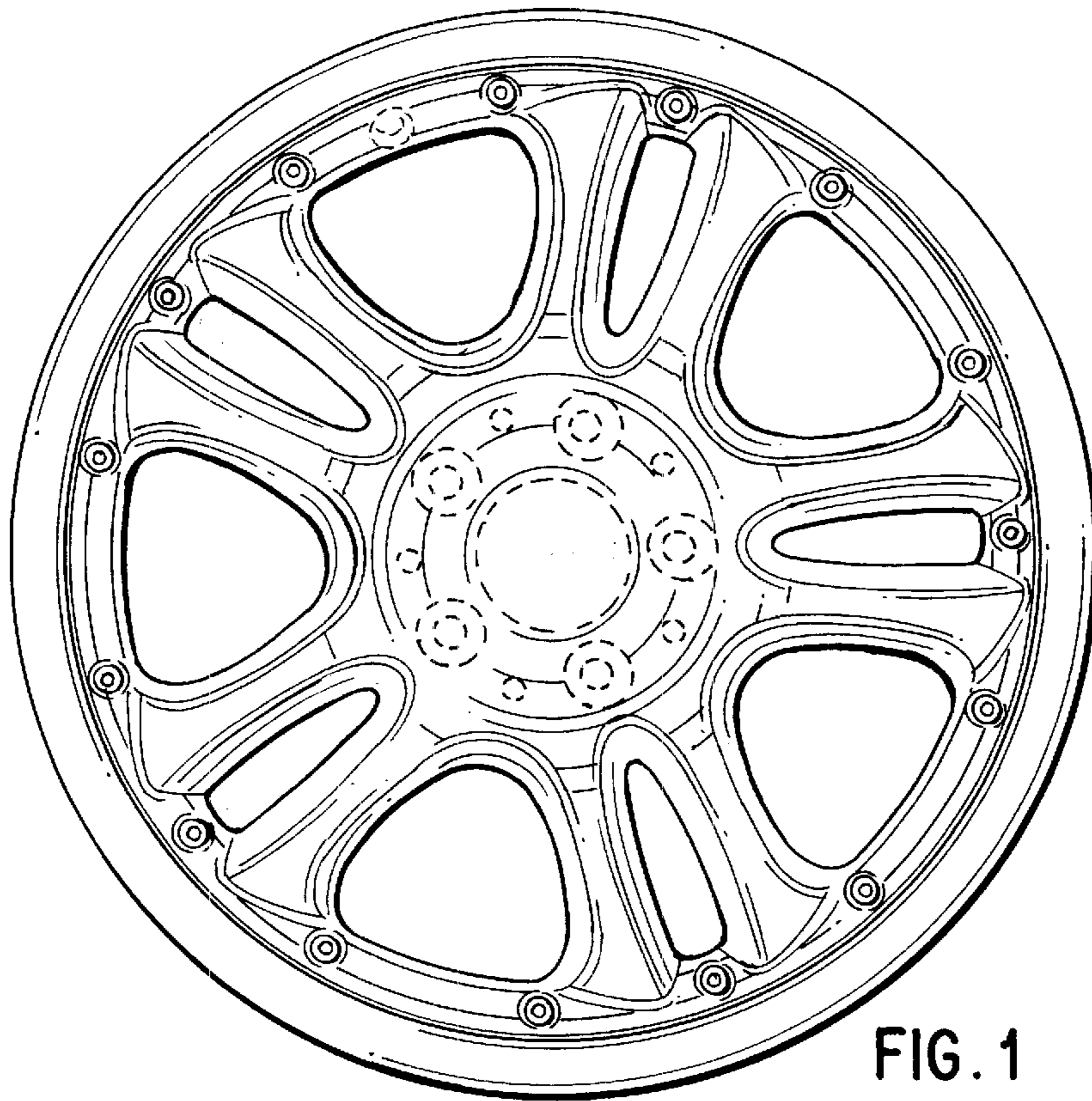

FIG. 1

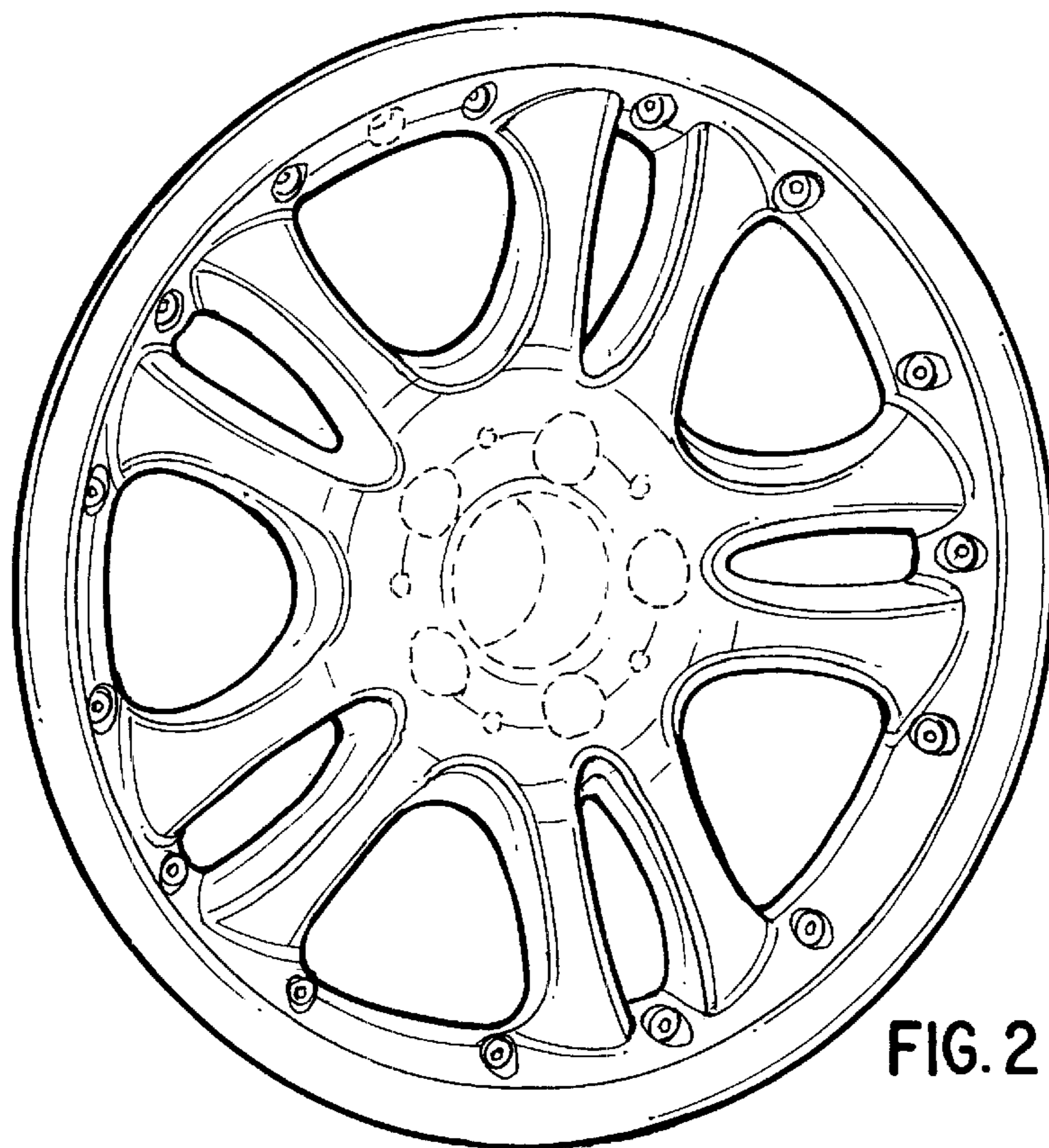

FIG. 2

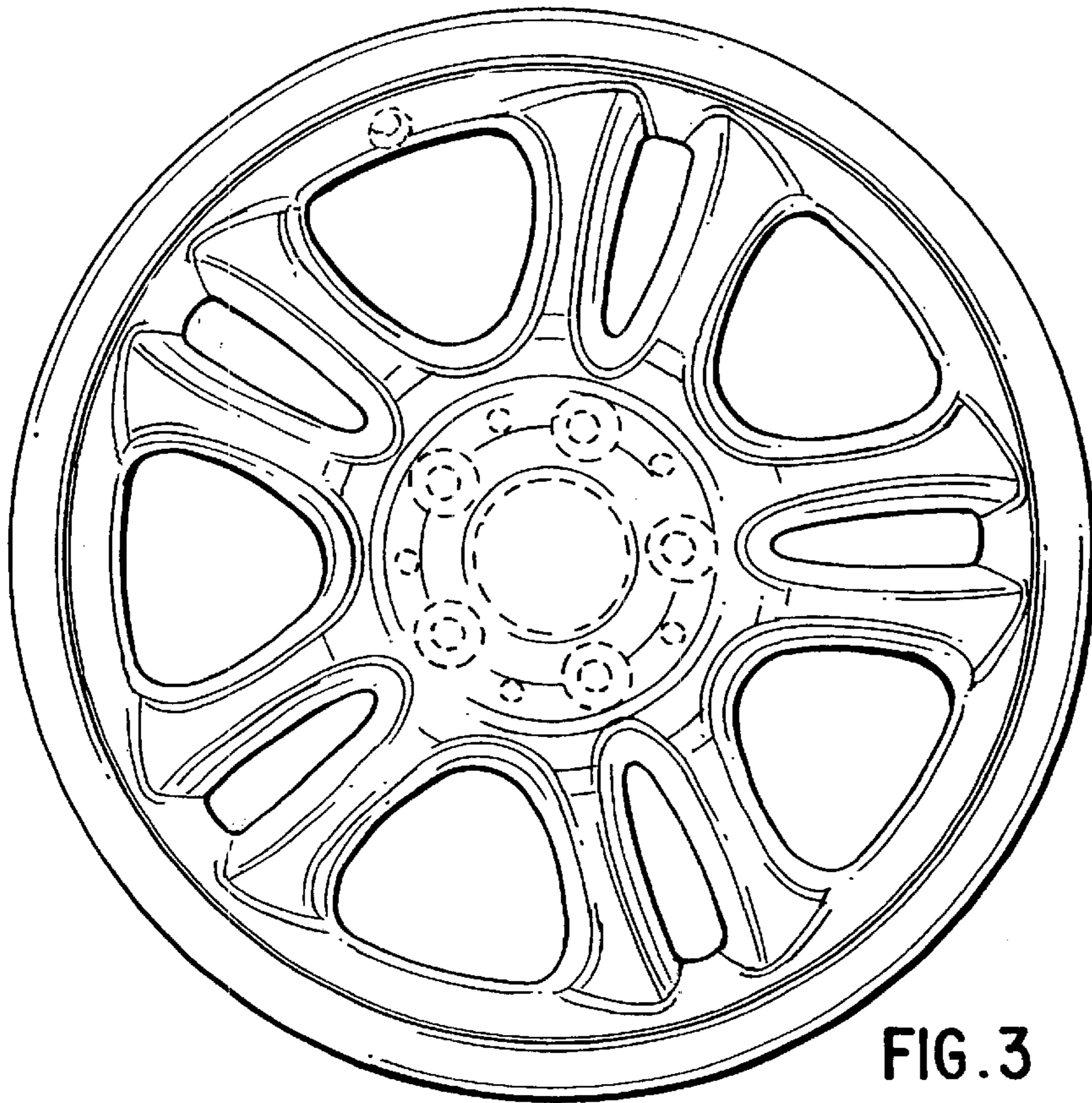

FIG. 3

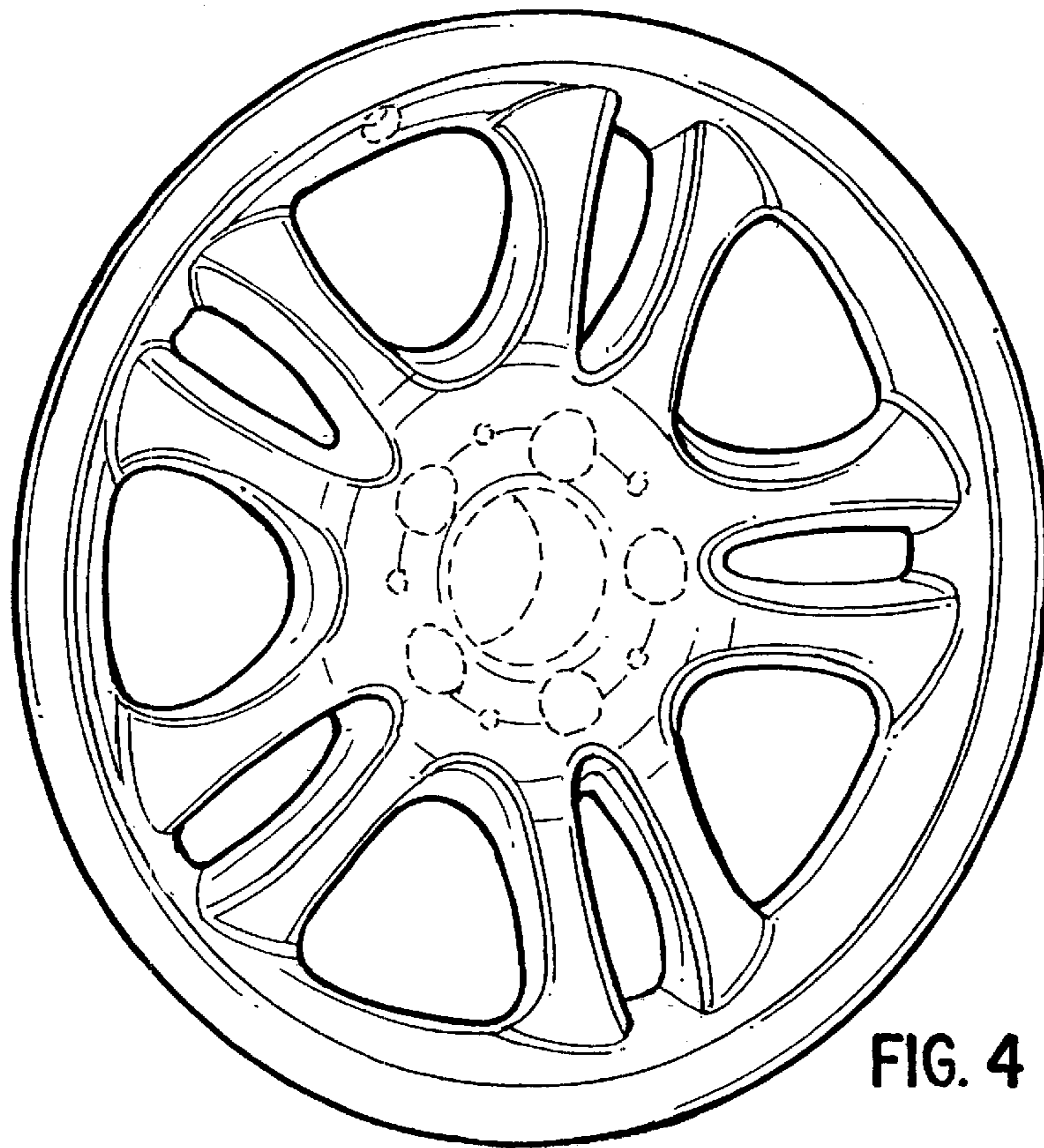

FIG. 4