



US00D467806S

(12) **United States Design Patent** (10) **Patent No.:** **US D467,806 S**
Baron et al. (45) **Date of Patent:** **** Dec. 31, 2002**

(54) **CONTAINER**

(75) Inventors: **Richard D. Baron**, Zephyrhills, FL (US); **Malcolm C. Smith**, Dade City, FL (US); **Carl R. Spoeth**, Bayonet Point, FL (US); **Steven A. Garbee**, Seffner, FL (US); **Valdemiro M. Quadros**, Zephyrhills, FL (US)

(73) Assignee: **Vitality Foodservice, Inc.**, Tampa, FL (US)

(**) Term: **14 Years**

(21) Appl. No.: **29/095,558**

(22) Filed: **Oct. 26, 1998**

Related U.S. Application Data

(60) Continuation-in-part of application No. 29/032,751, filed on Dec. 27, 1994, now abandoned, which is a division of application No. 29/007,735, filed on May 3, 1993, now Pat. No. Des. 355,854, which is a division of application No. 07/567,349, filed on Aug. 14, 1990, now Pat. No. Des. 340,866.

(51) **LOC (7) Cl.** **09-01**

(52) **U.S. Cl.** **D9/520; D9/523; D9/528**

(58) **Field of Search** **D9/523, 528, 543, D9/533, 564, 566, 570, 559, 520; 215/382, 383, 384**

(56) **References Cited**

U.S. PATENT DOCUMENTS

D81,679 * 7/1930 Webber D9/566
D146,127 * 12/1946 Billups D9/528
D148,216 * 12/1947 Dennis
D156,089 * 11/1949 Fuerst D9/564
D167,991 10/1952 Mack
D178,131 * 6/1956 Lorenzen D9/566
D192,619 4/1962 Mojonnier
D192,621 4/1962 Mojonnier
D193,217 7/1962 Cassell
D193,741 10/1962 Westhoven
D194,564 2/1963 Mojonnier

D196,939 11/1963 Cigognetti
D197,993 4/1964 Mojonnier
D197,994 4/1964 Mojonnier
D198,475 6/1964 Mojonnier
3,176,879 4/1965 Mojonnier
D203,074 11/1965 Adell
3,338,459 8/1967 Smith
D209,342 11/1967 Thomson et al.
D211,316 6/1968 Kustermann et al.
D213,040 12/1968 Schaper et al.
D214,021 * 5/1969 Bacialli D9/523
D218,019 7/1970 Lattraye
D218,281 8/1970 Diener
D223,334 4/1972 Hayes
D224,511 8/1972 Koenigsberg
D226,703 4/1973 Broadhead
D227,002 5/1973 Broadhead
D228,124 * 8/1973 Yamakawa D9/523
3,756,398 9/1973 Green et al.
D236,807 9/1975 Schmit
3,940,002 2/1976 Schiemann
3,948,105 4/1976 Johnson, Jr.
D242,770 12/1976 Mitchell
D247,770 4/1978 Sagona
D255,093 * 5/1980 Hartung et al. D9/564
4,228,758 10/1980 Dornau et al.
4,252,073 2/1981 Hartung et al.
D269,948 8/1983 Janssen
4,579,260 4/1986 Young et al.
D288,531 * 3/1987 Tarasevich et al. D9/528
D289,612 5/1987 Carlson
D289,976 5/1987 Humphries
D294,117 2/1988 Rogler et al.
D294,118 2/1988 Papa
D294,463 3/1988 Lang
D294,678 3/1988 Papa
D295,381 4/1988 Papa
D296,668 7/1988 Stavish
4,816,273 3/1989 Smith et al.
D302,522 8/1989 Charboneau et al.
D303,083 8/1989 Powell et al.
4,901,878 2/1990 Humphries
D308,825 6/1990 Hoyt
4,952,068 8/1990 Flint
D315,869 4/1991 Collette
D319,976 9/1991 Wortley et al.
D320,157 9/1991 Nobile et al.
D320,931 10/1991 Siegel
D321,320 11/1991 Halm

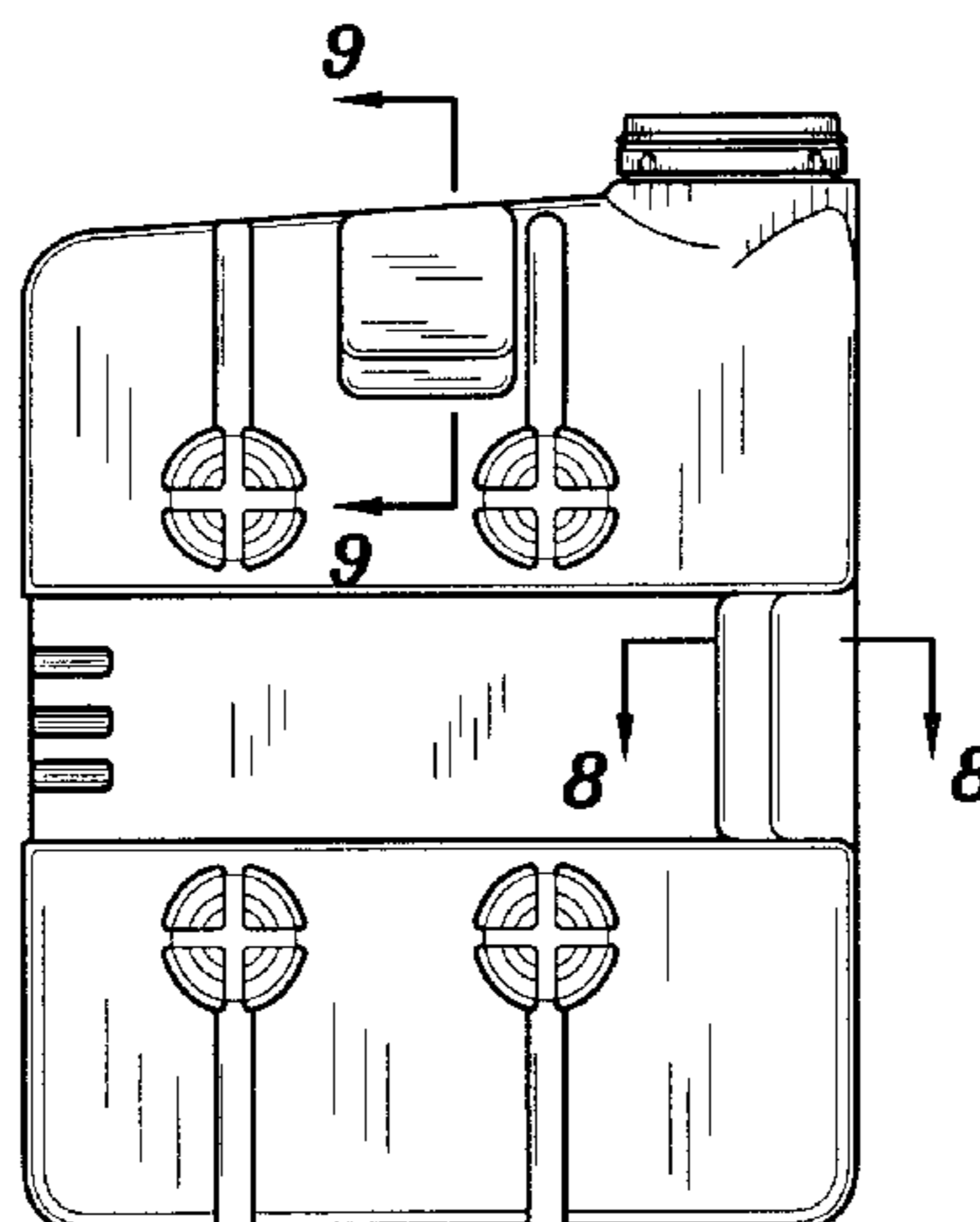

D322,383 12/1991 Jones
5,123,575 6/1992 Li

* cited by examiner

Primary Examiner—Lucy Lieberman
(74) *Attorney, Agent, or Firm*—Carlton Fields, P.A.

(57) **CLAIM**

The ornamental design for a container, as shown and described.

DESCRIPTION

FIG. 1 is a left side elevation of a container showing our new design;

FIG. 2 is a front elevation thereof;

FIG. 3 is a right side elevation thereof;

FIG. 4 is a rear elevation thereof;

FIG. 5 is a top plan view thereof;

FIG. 6 is a bottom plan view thereof;

FIG. 7 is a fragmentary cross sectional view in perspective of a lower portion of FIG. 1;

FIG. 8 is a fragmentary cross sectional view taken on line 8—8 in FIG. 1;

FIG. 9 is a fragmentary cross sectional view taken on line 9—9 in FIG. 1;

FIG. 10 is a fragmentary cross sectional view taken on line 10—10 in FIG. 4;

FIG. 11 is a left side elevation of a second embodiment of the container;

FIG. 12 is a front elevation of FIG. 11;

FIG. 13 is a right side elevation of FIG. 11;

FIG. 14 is a rear elevation of FIG. 11;

FIG. 15 is a top plan view of FIG. 11;

FIG. 16 is a bottom plan view of FIG. 11;

FIG. 17 is a fragmentary cross sectional view in perspective of a lower portion of FIG. 11;

FIG. 18 is a fragmentary cross sectional view taken on line 18—18 in FIG. 11

FIG. 19 is a fragmentary cross sectional view taken on line 19—19 in FIG. 11;

FIG. 20 is a fragmentary cross sectional view taken on line 20—20 in FIG. 14;

FIG. 21 is a fragmentary right side elevation of a third embodiment of the container, the portion of the third embodiment that is not shown is the same as the second embodiment;

FIG. 22 is a fragmentary rear elevation of FIG. 21;

FIG. 23 is a fragmentary left side elevation of FIG. 21;

FIG. 24 is a fragmentary right side elevation of a fourth embodiment of the container, the portion of the fourth embodiment that is not shown is the same as the second embodiment;

FIG. 25 is a fragmentary rear elevation of FIG. 24;

FIG. 26 is a fragmentary left side elevation of FIG. 24;

FIG. 27 is a fragmentary right side elevation of a fifth embodiment of the container, the portion of the fifth embodiment that is not shown is the same as the second embodiment;

FIG. 28 is a fragmentary rear elevation of FIG. 27;

FIG. 29 is a fragmentary left side elevation of FIG. 27;

FIG. 30 is a fragmentary right side elevation of a sixth embodiment of the container, the portion of the sixth embodiment that is not shown is the same as the second embodiment;

FIG. 31 is a fragmentary rear elevation of FIG. 30;

FIG. 32 is a fragmentary left side elevation of FIG. 30;

FIG. 33 is a fragmentary right side elevation of a seventh embodiment of the container, the portion of the seventh embodiment that is not shown is the same as the second embodiment;

FIG. 34 is a fragmentary rear elevation of FIG. 33;

FIG. 35 is a fragmentary left side elevation of FIG. 33;

FIG. 36 is a fragmentary right side elevation of an eighth embodiment of the container, the portion of the eighth embodiment that is not shown is the same as the second embodiment;

FIG. 37 is a fragmentary rear elevation of FIG. 36; and,

FIG. 38 is a fragmentary left side elevation of FIG. 36.

The fragmentary views in the drawings are shown on an enlarged scale.

1 Claim, 8 Drawing Sheets

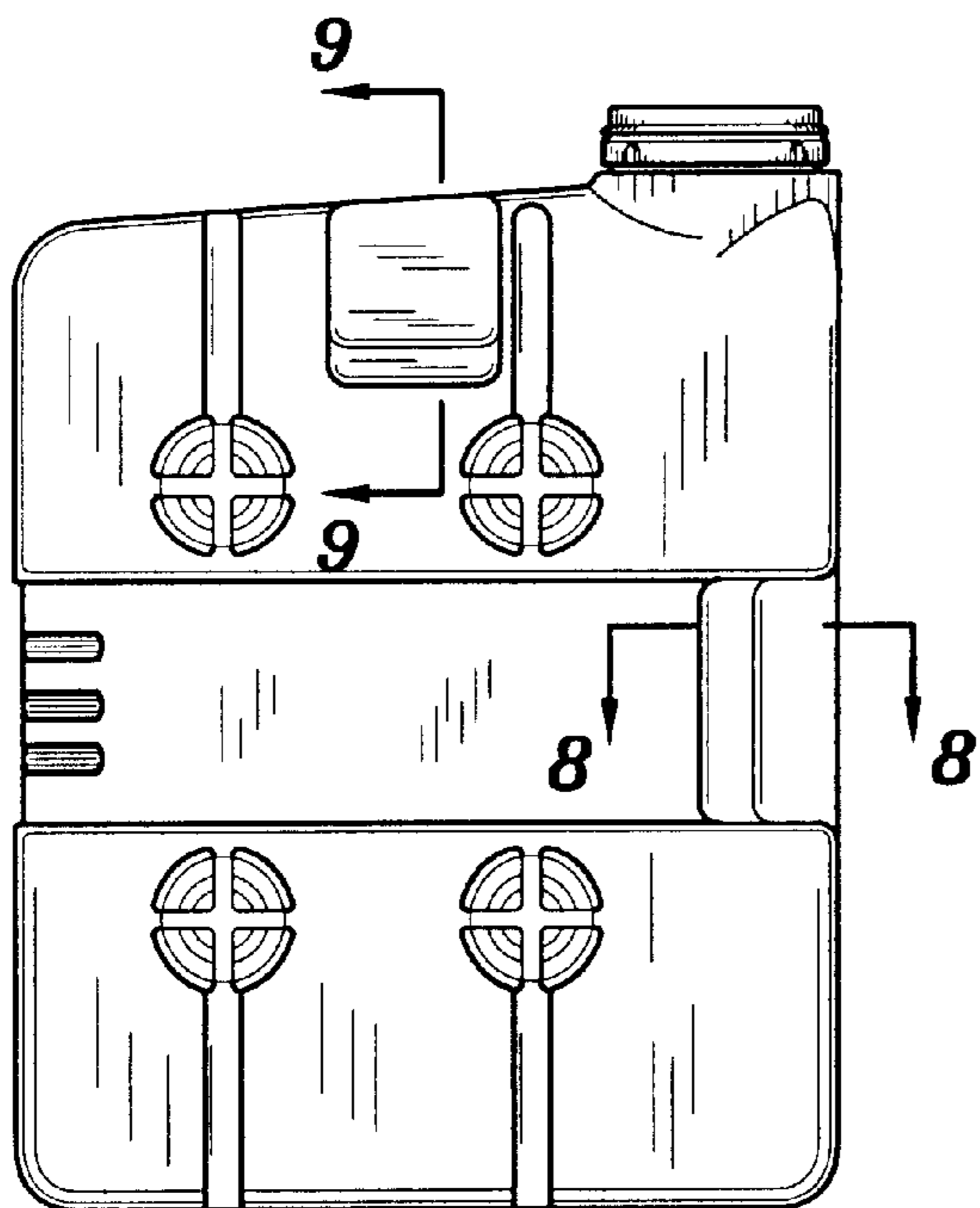

FIG. 1

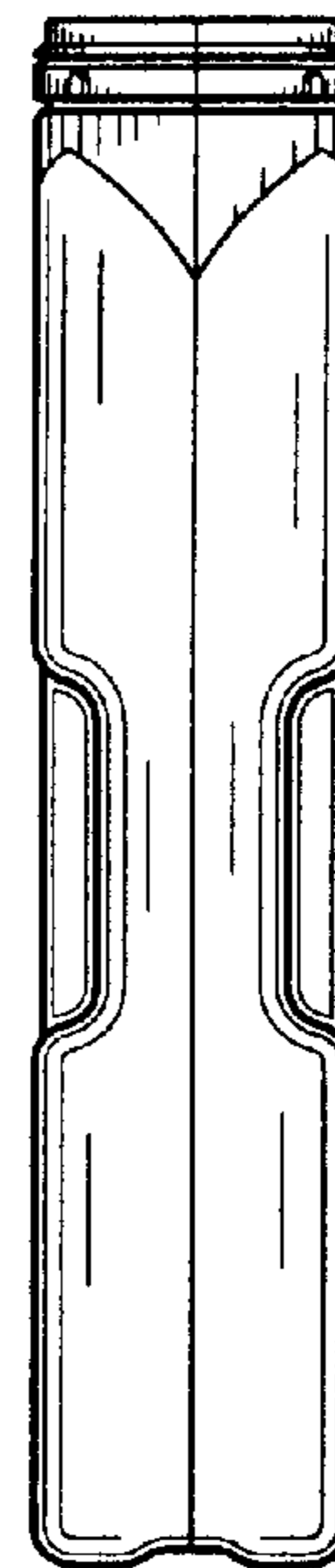

FIG. 2

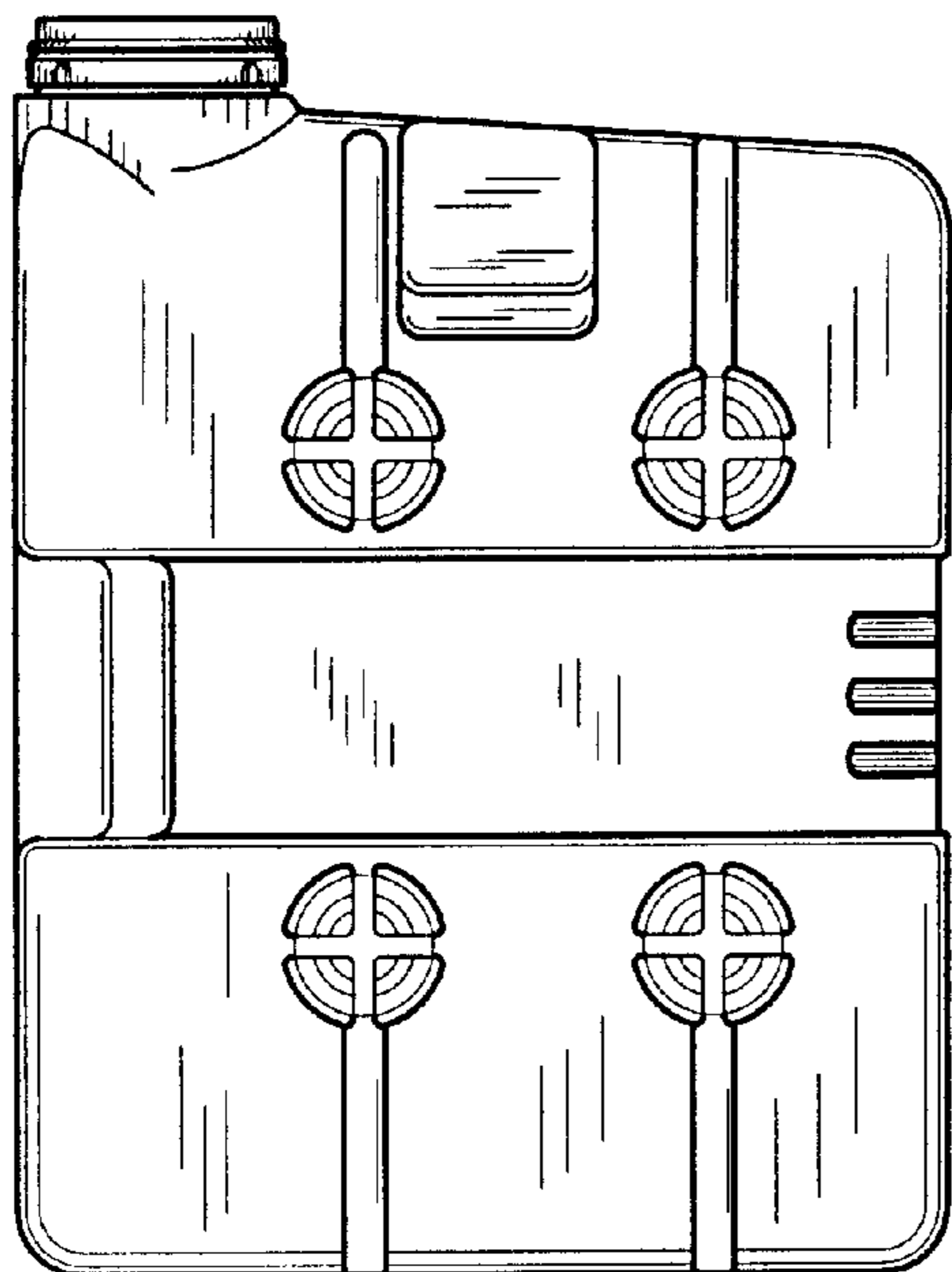

FIG. 3

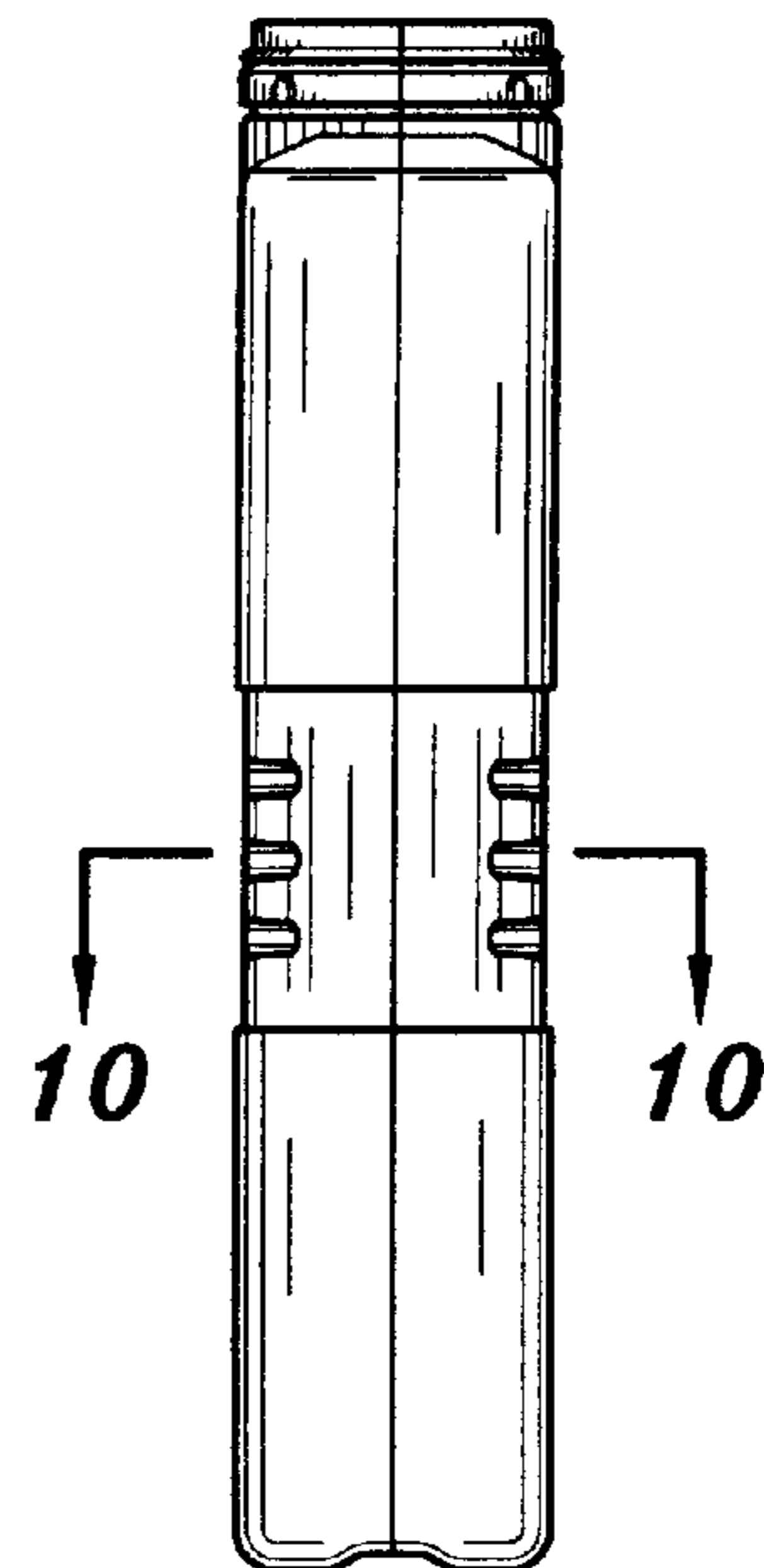

FIG. 4

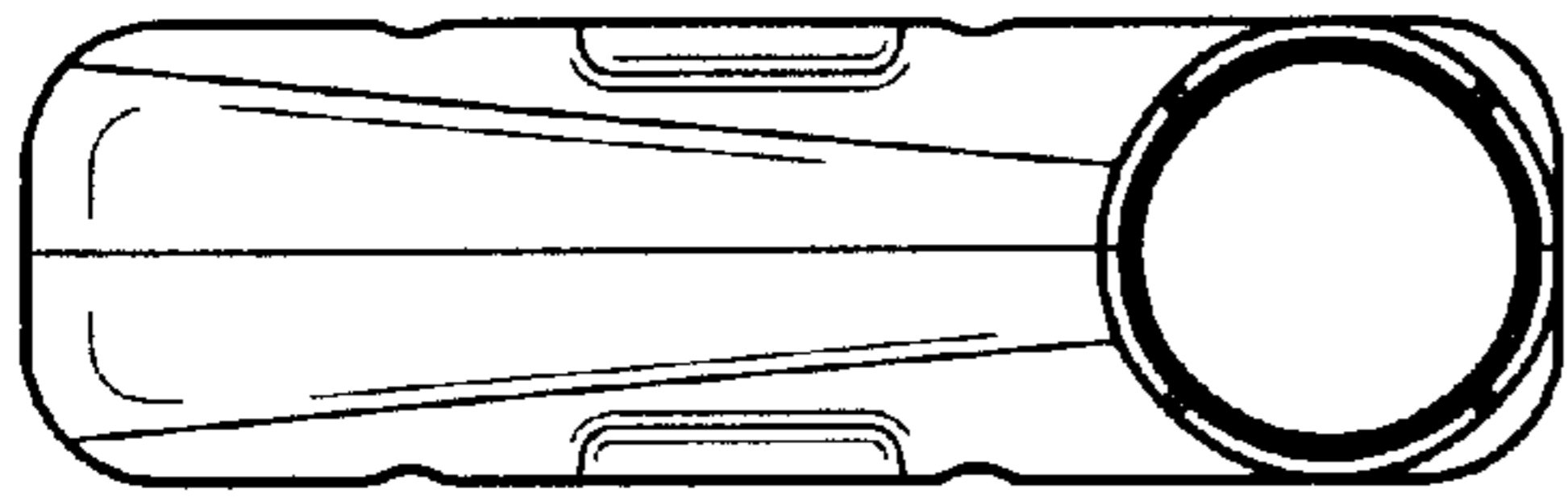

FIG. 5

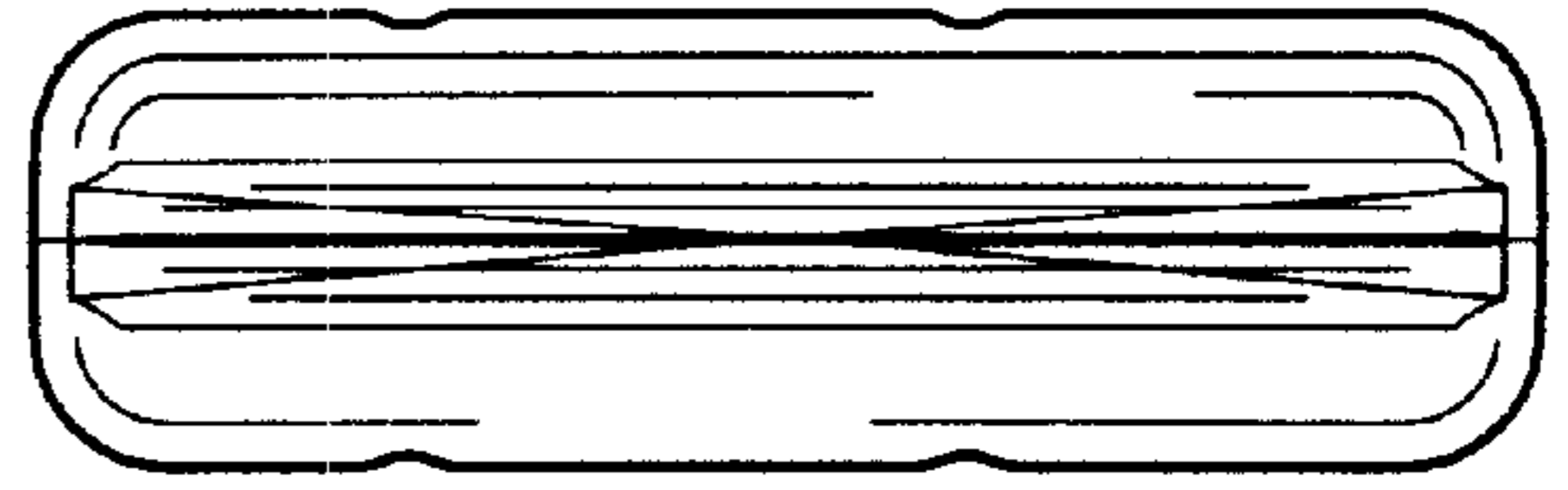

FIG. 6

FIG. 7

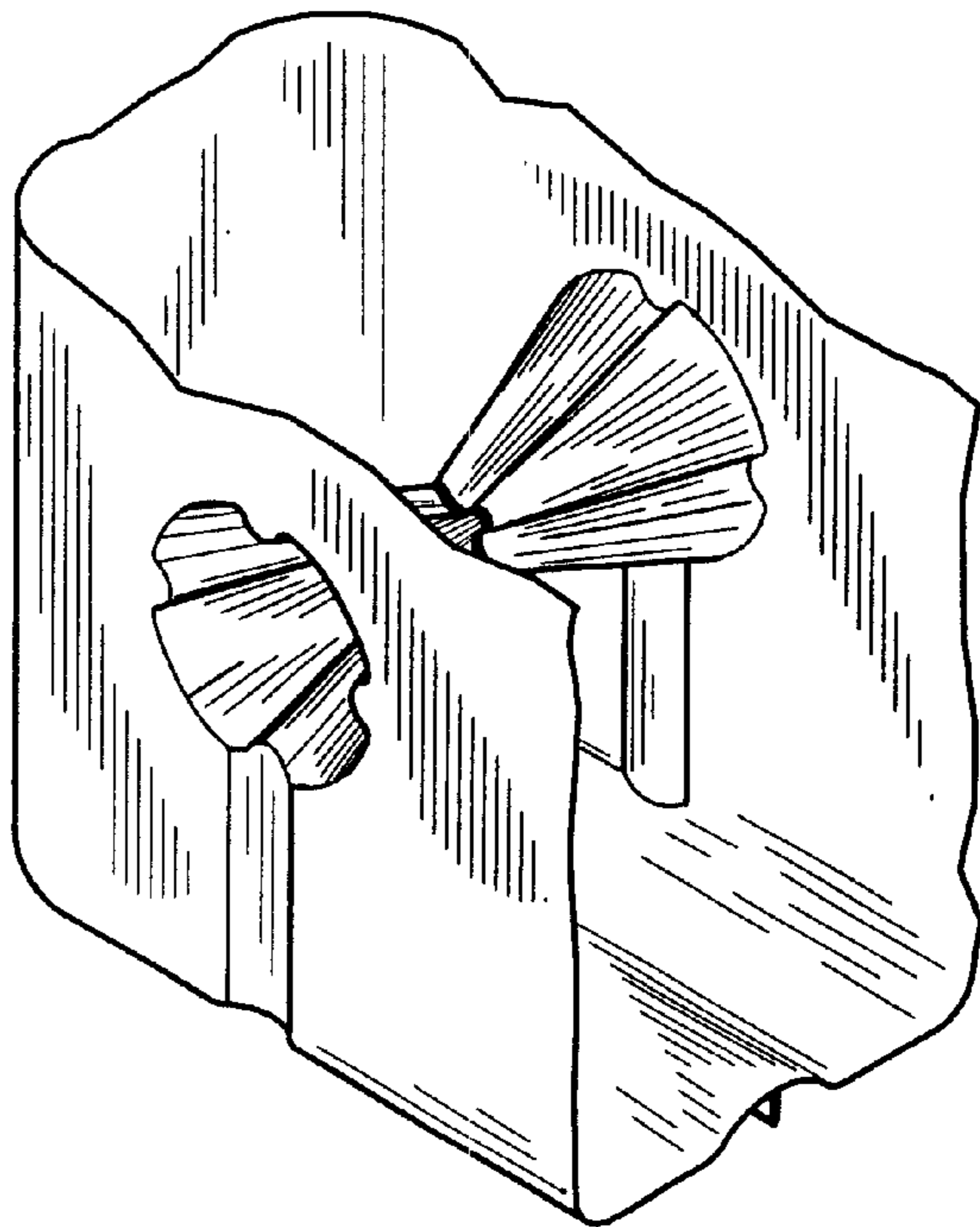
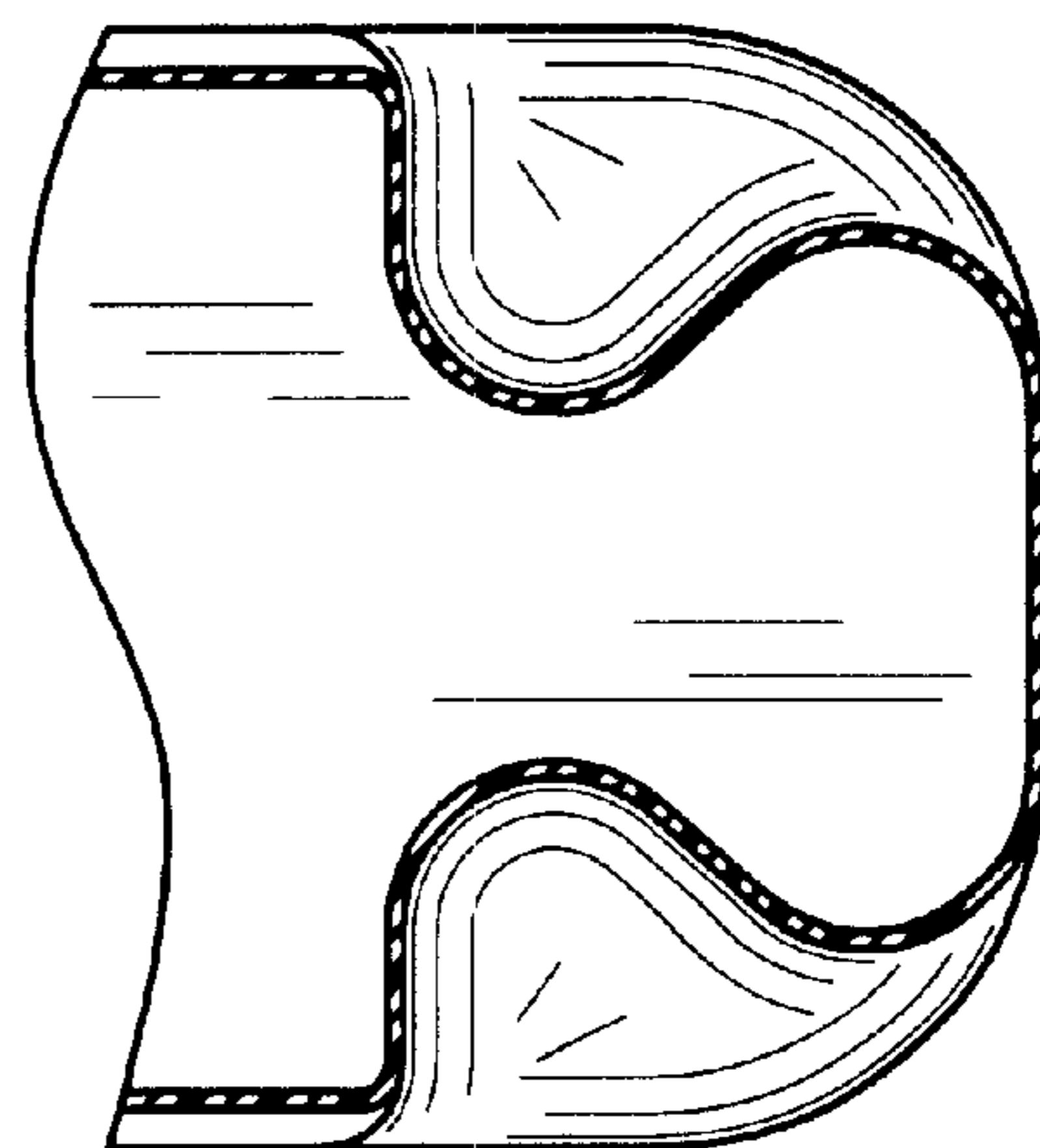

FIG. 8



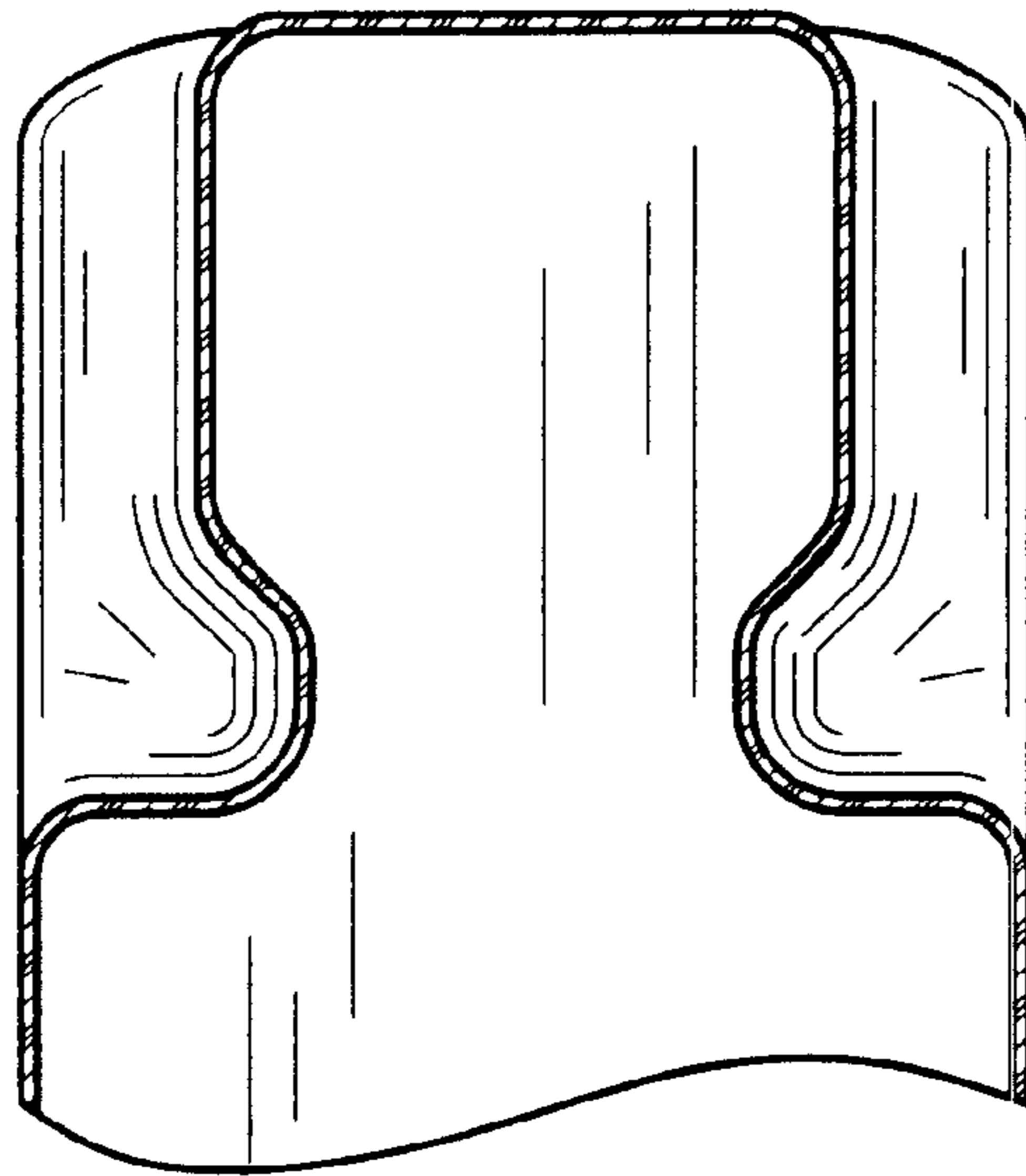

FIG. 9

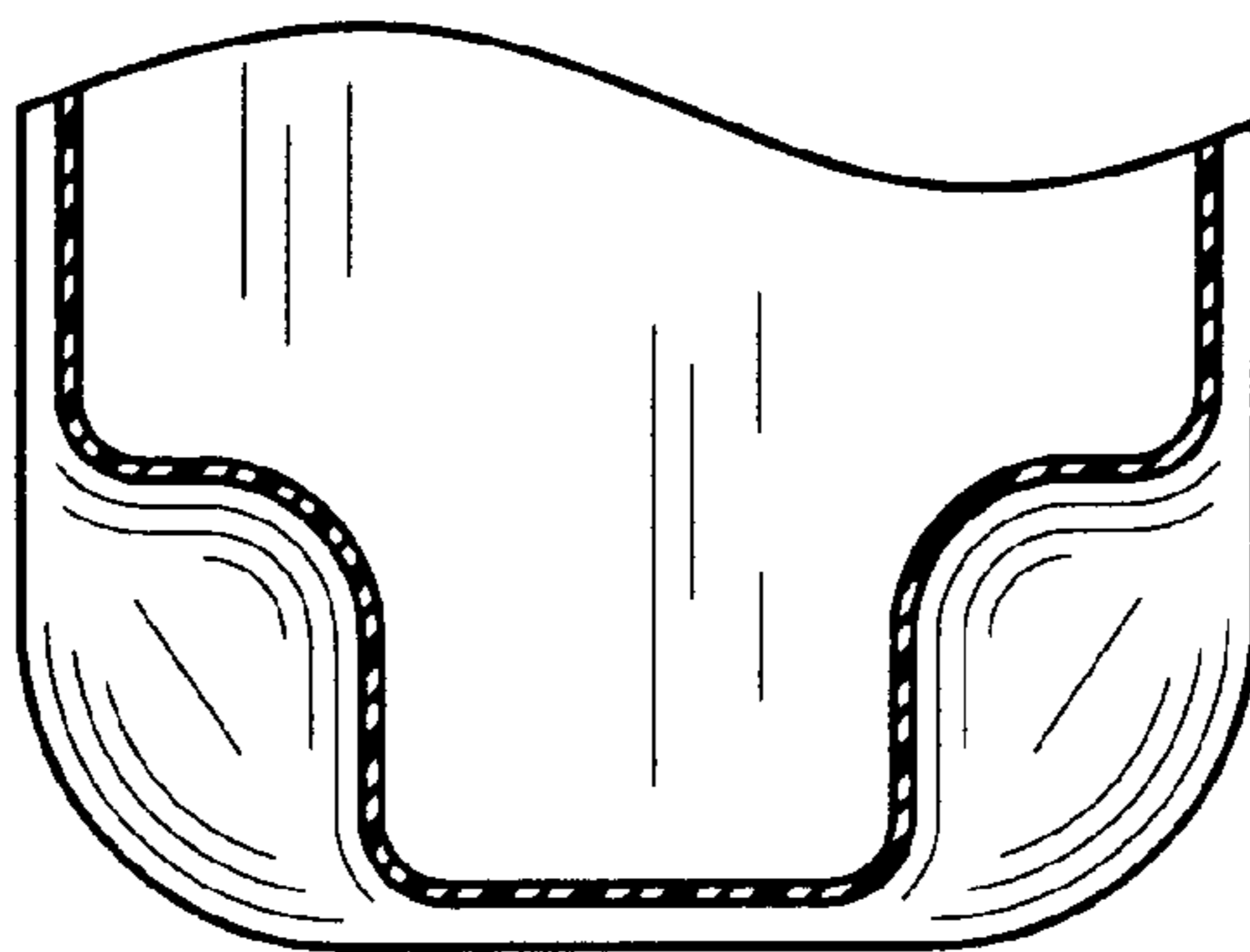

FIG. 10

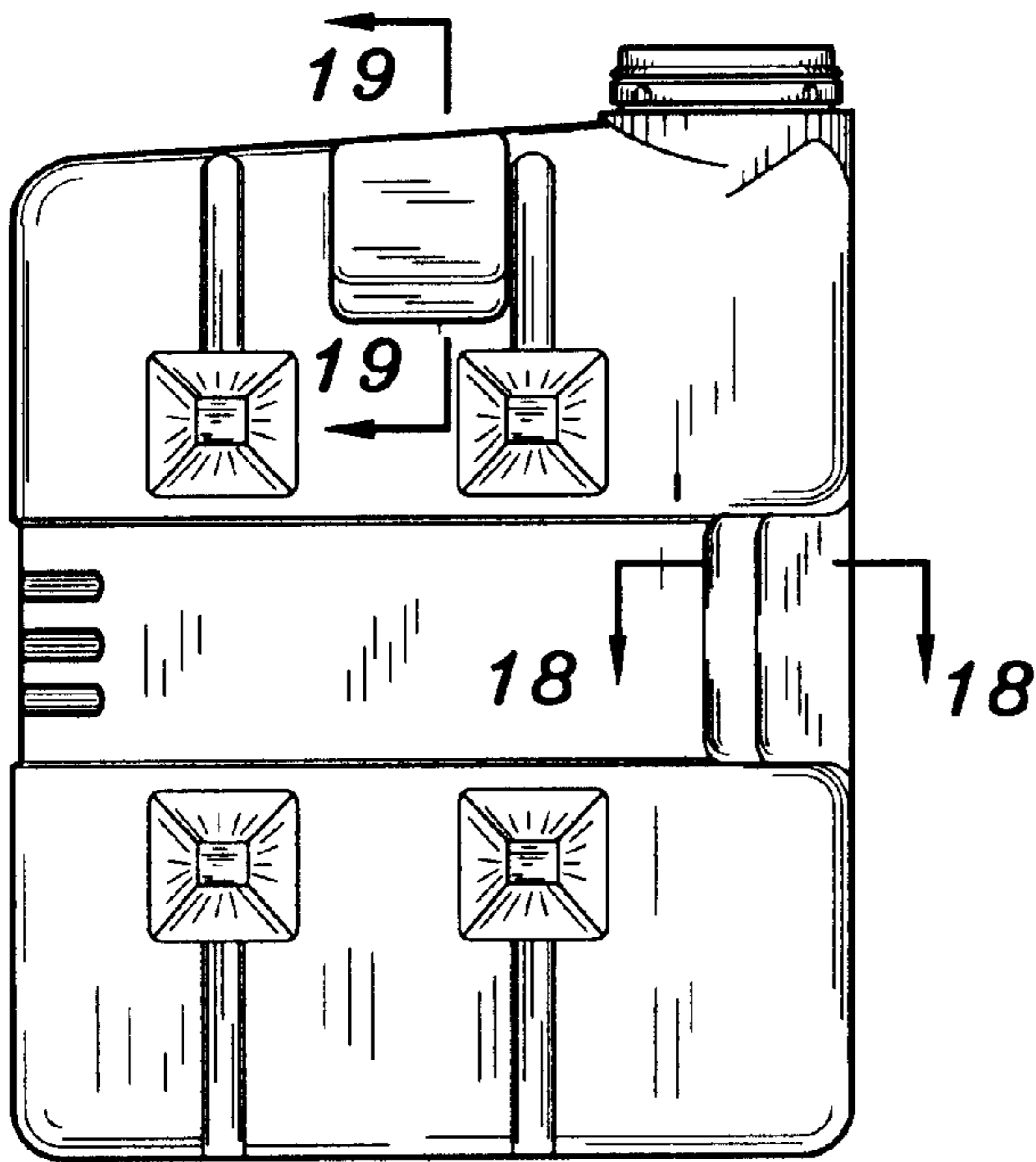

FIG. 11

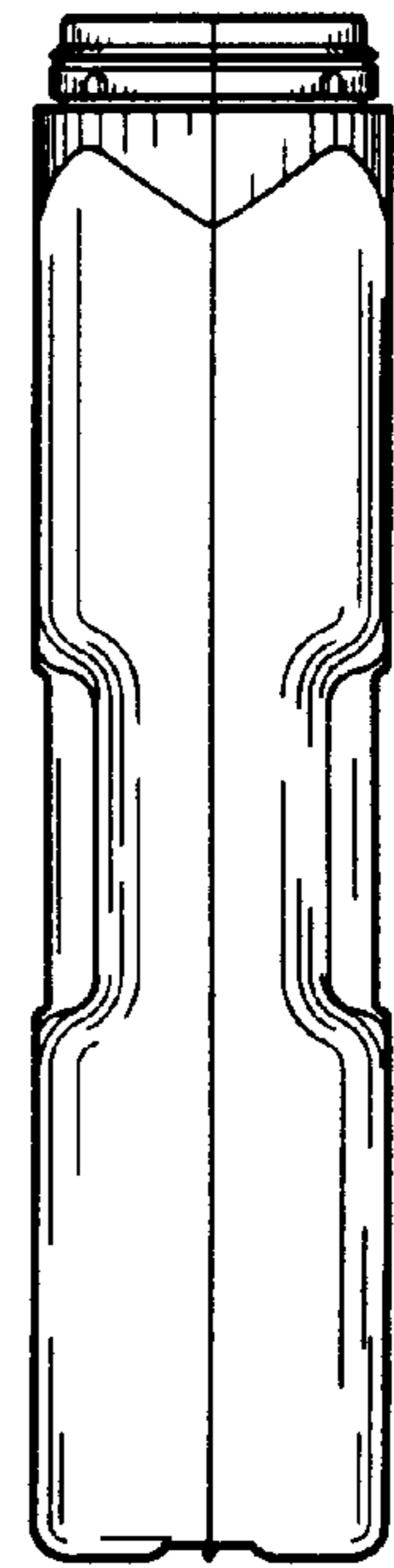

FIG. 12

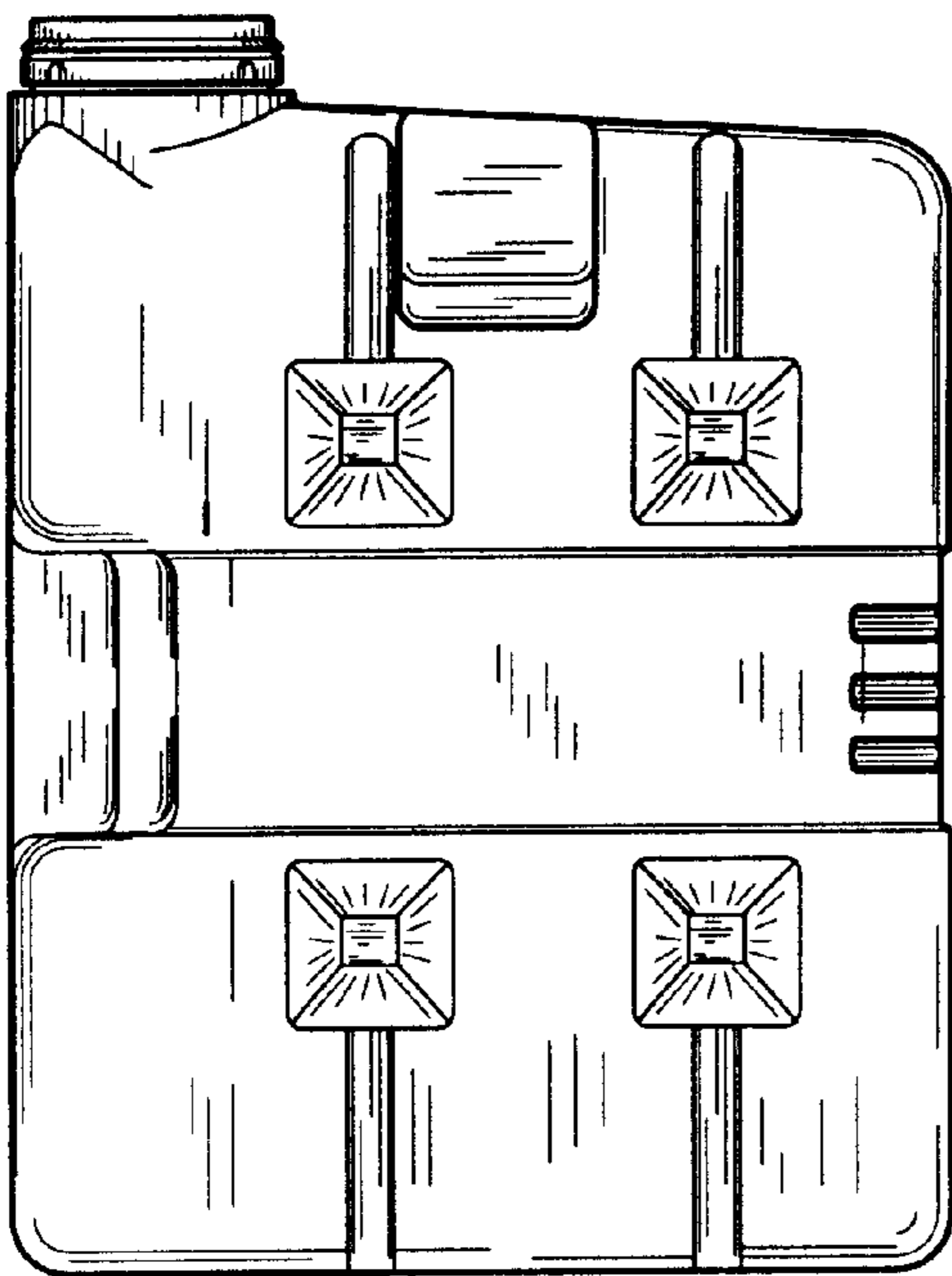

FIG. 13

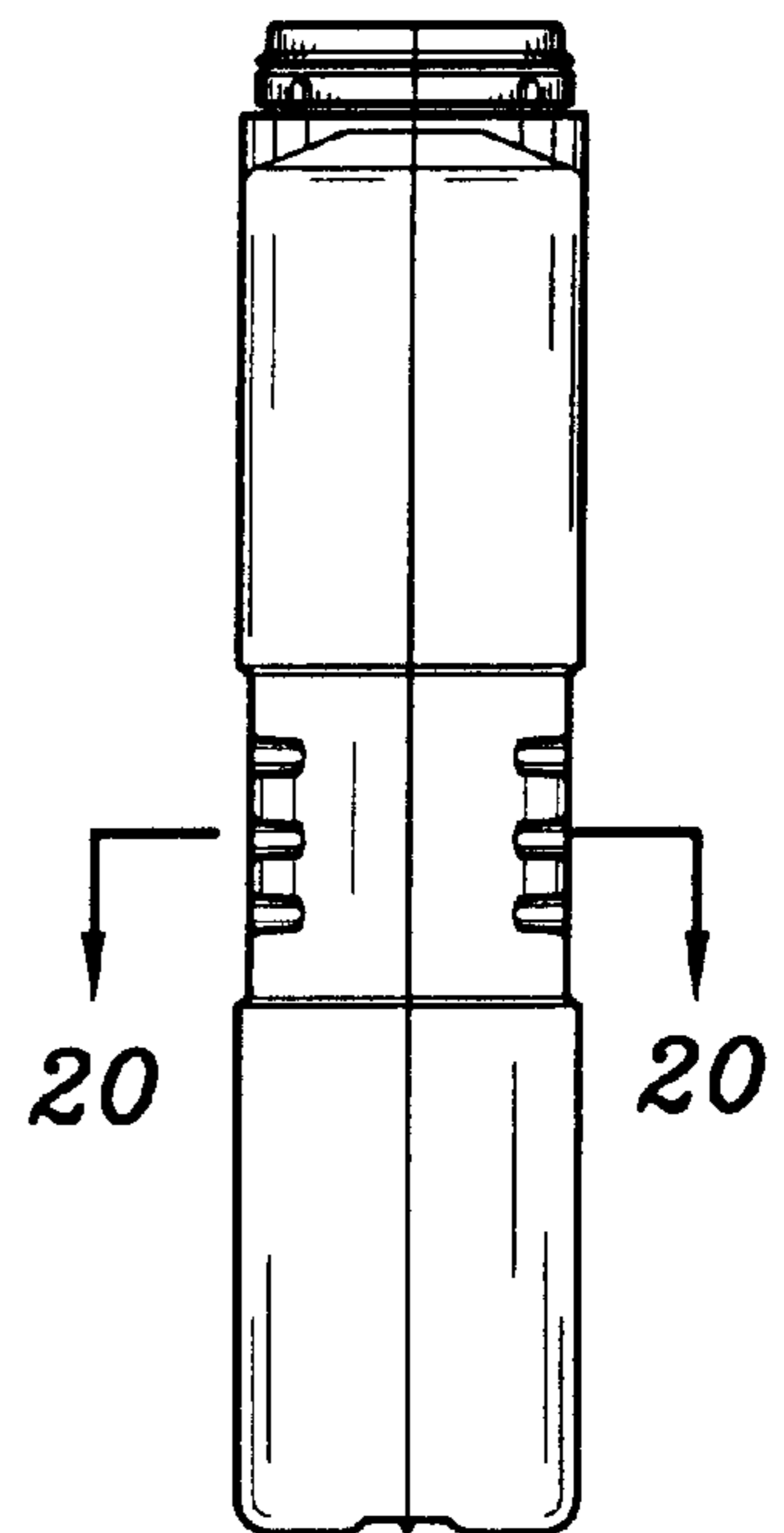

FIG. 14

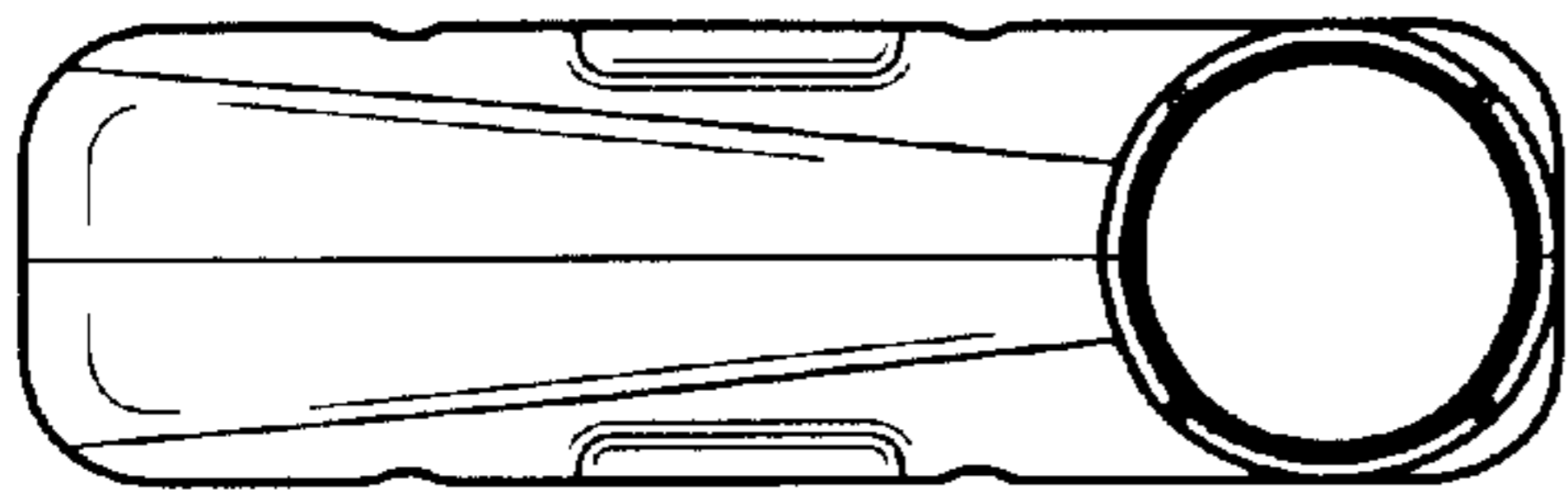

FIG. 15

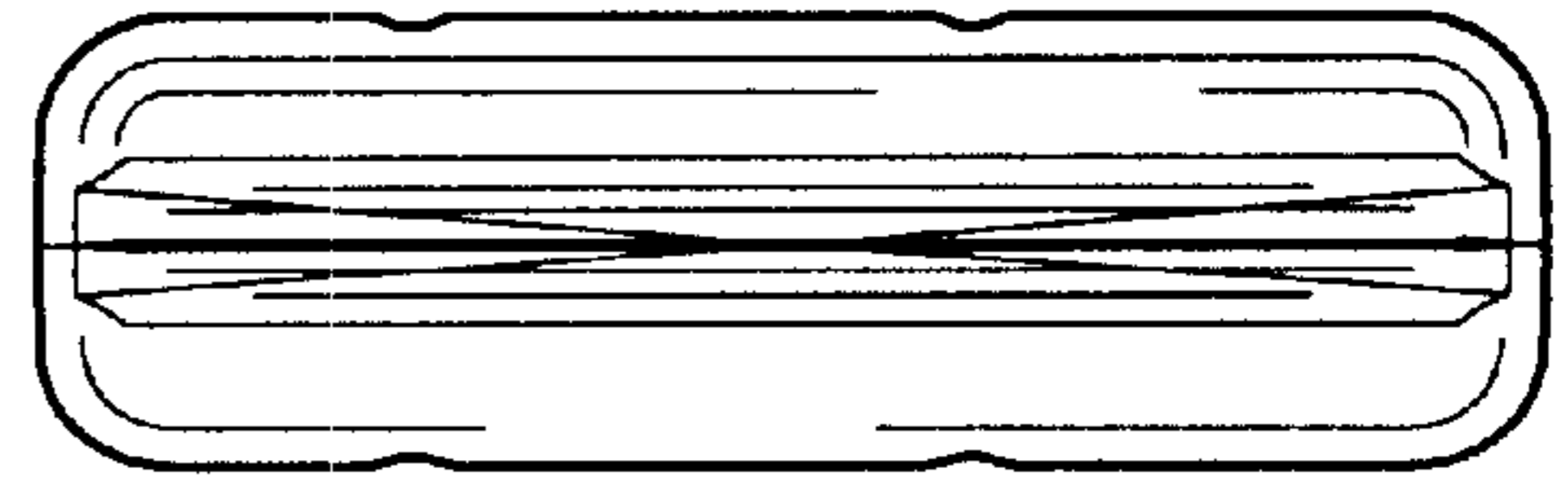

FIG. 16

FIG. 17

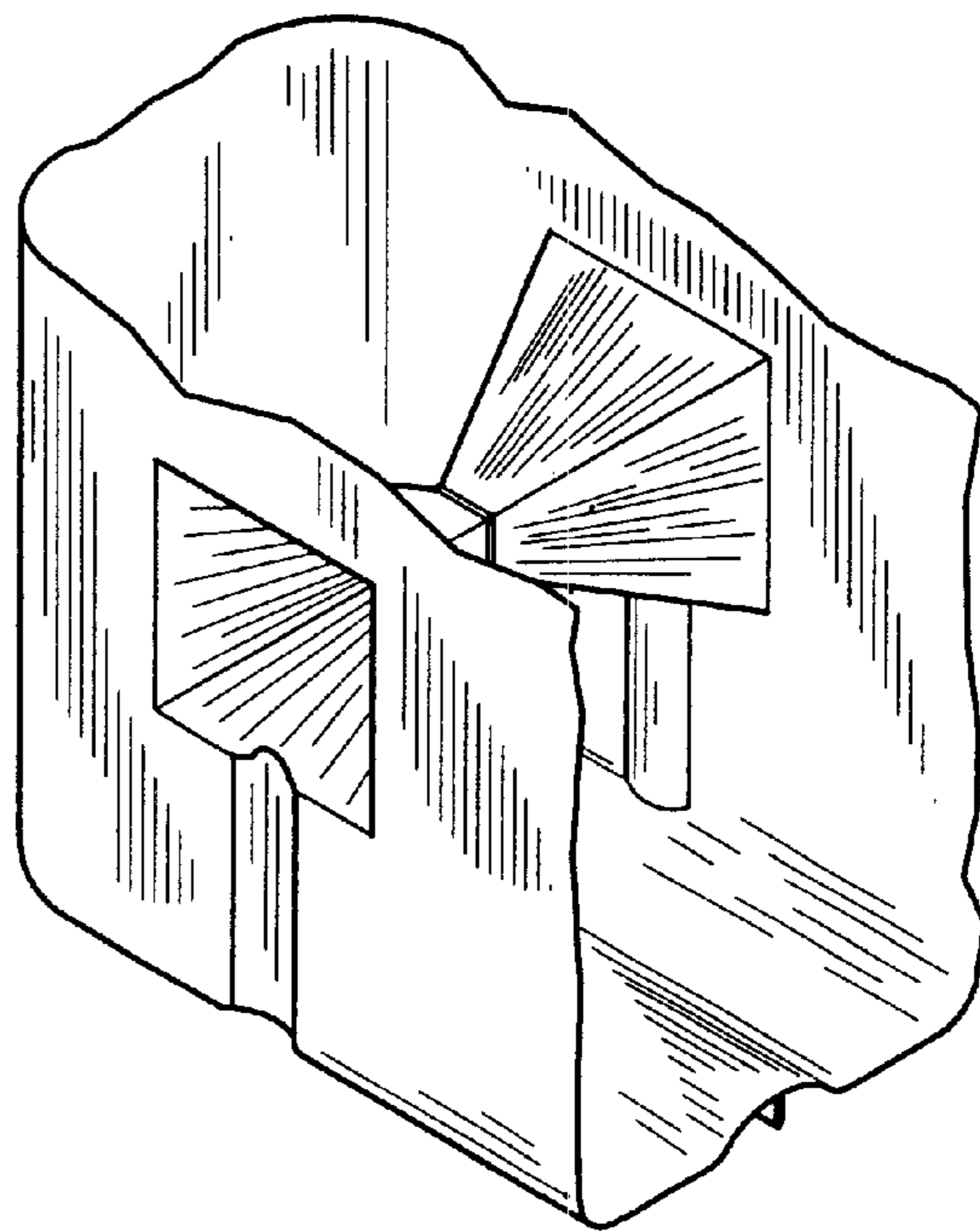
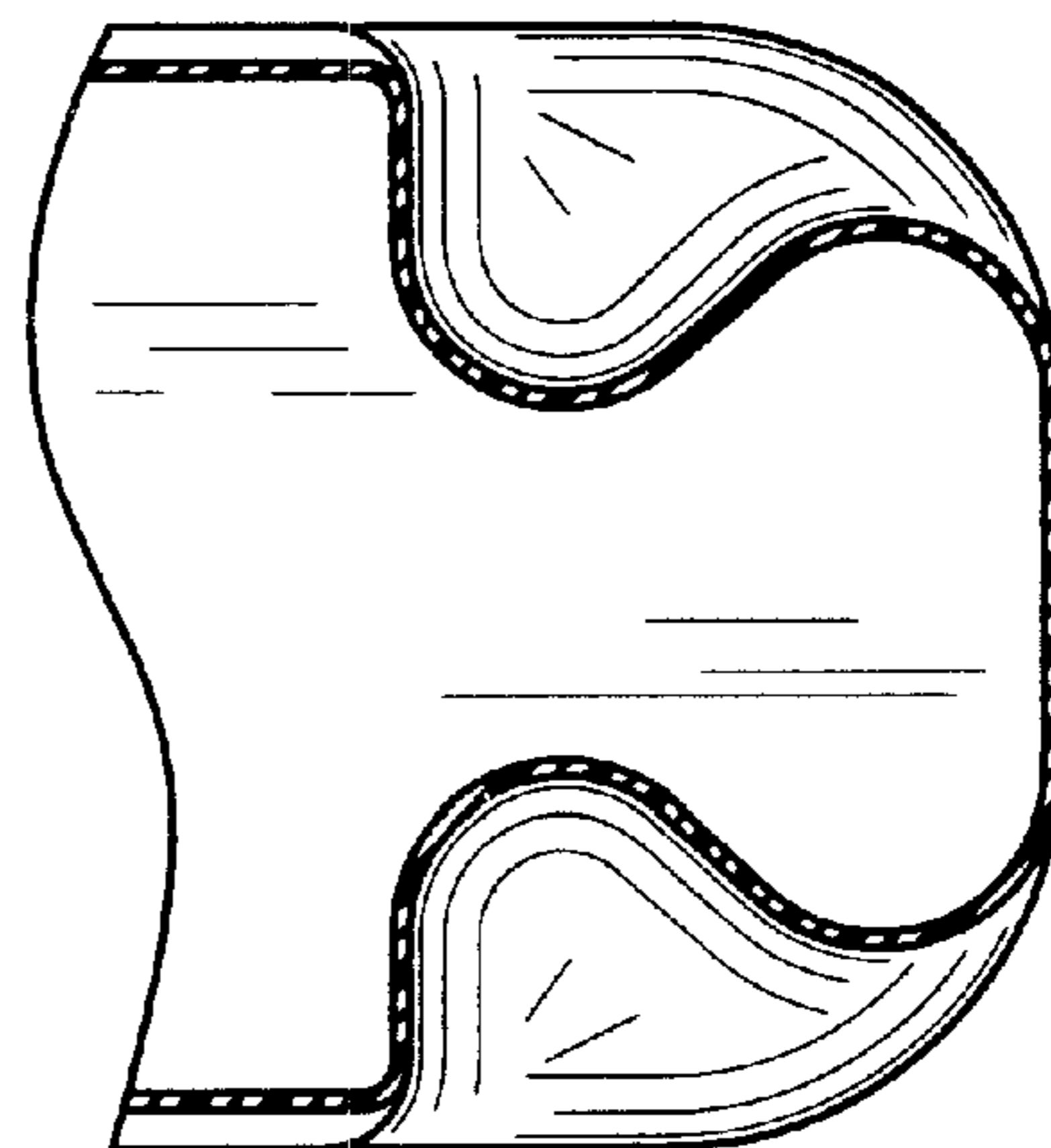

FIG. 18



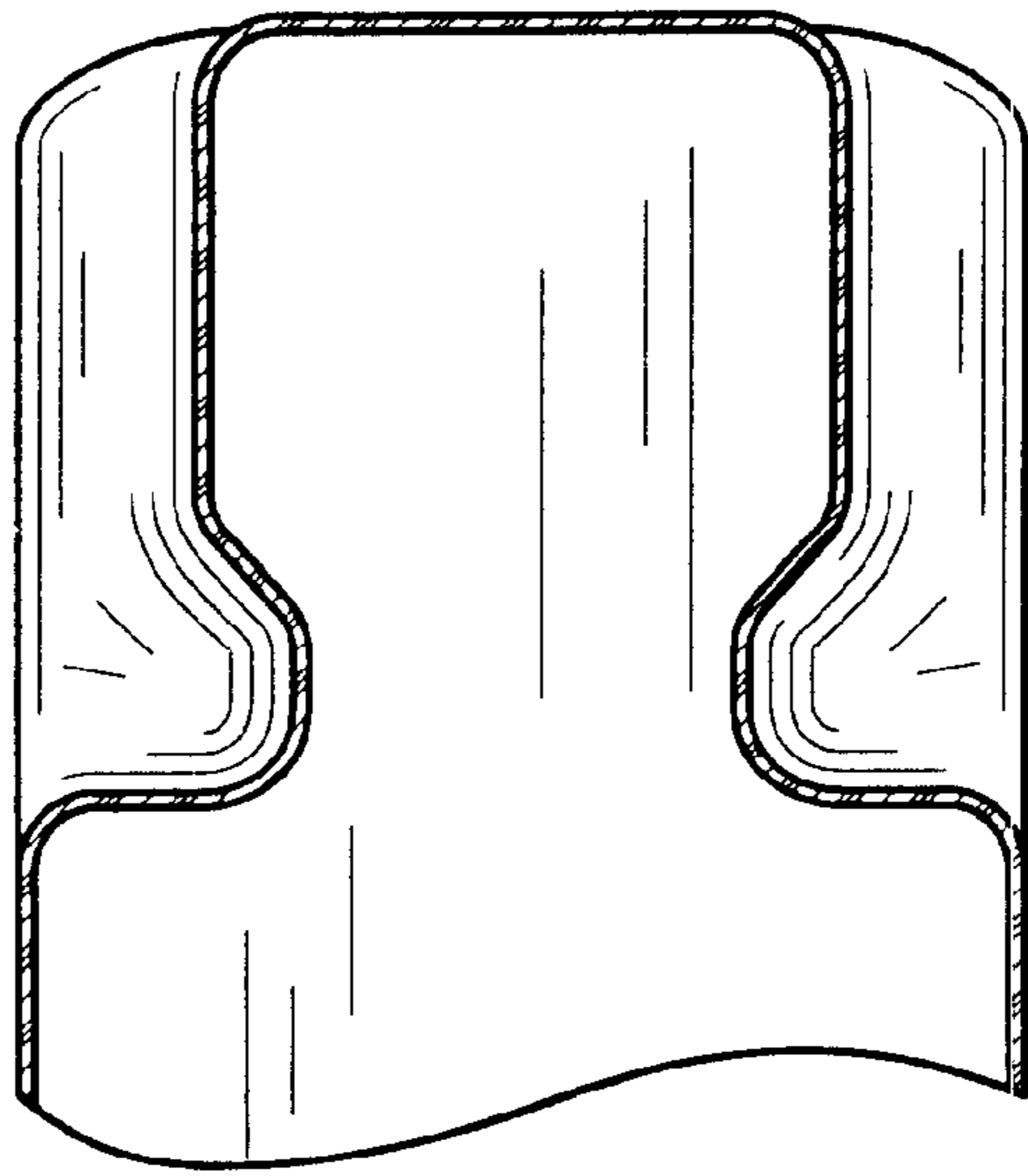

FIG. 19

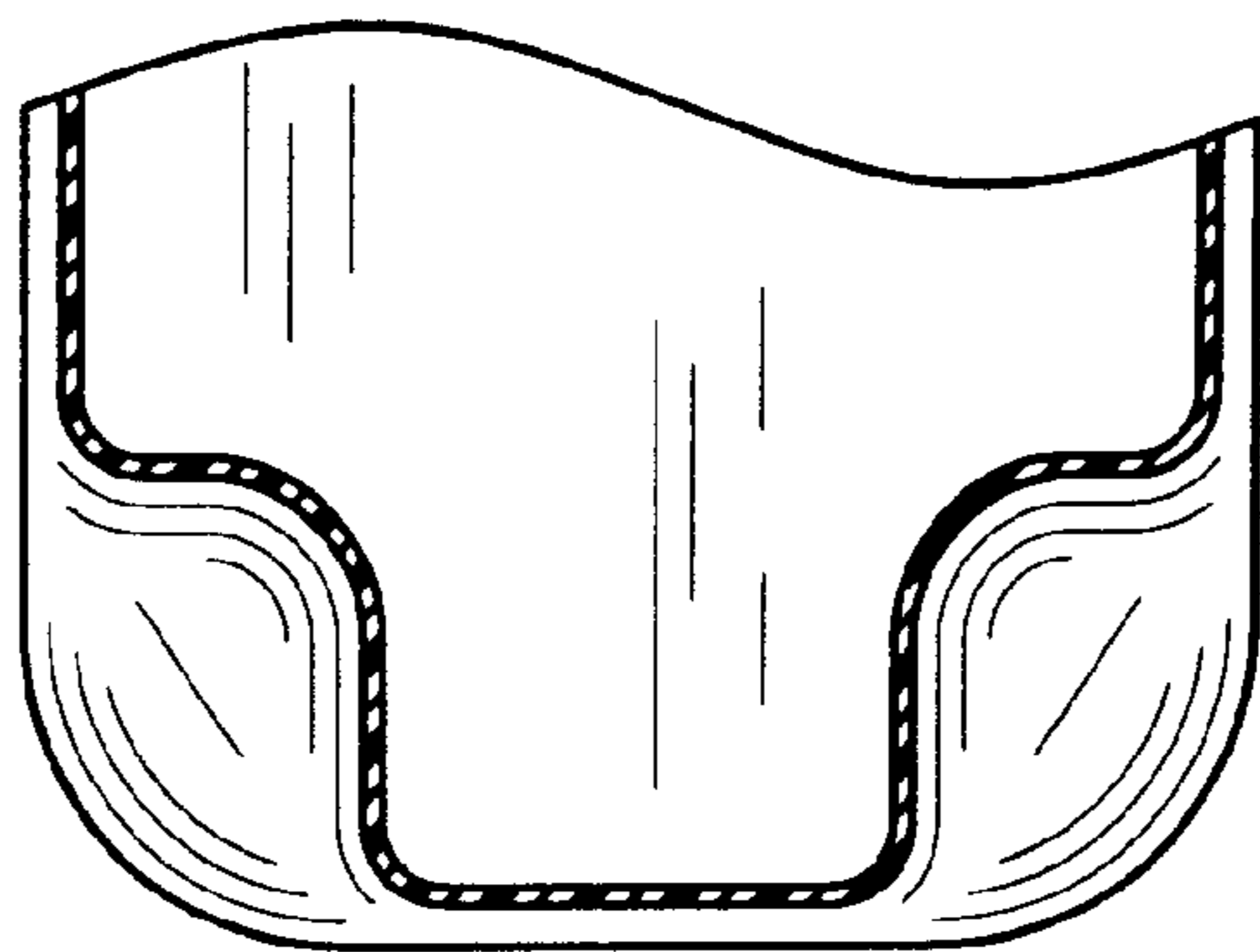

FIG. 20

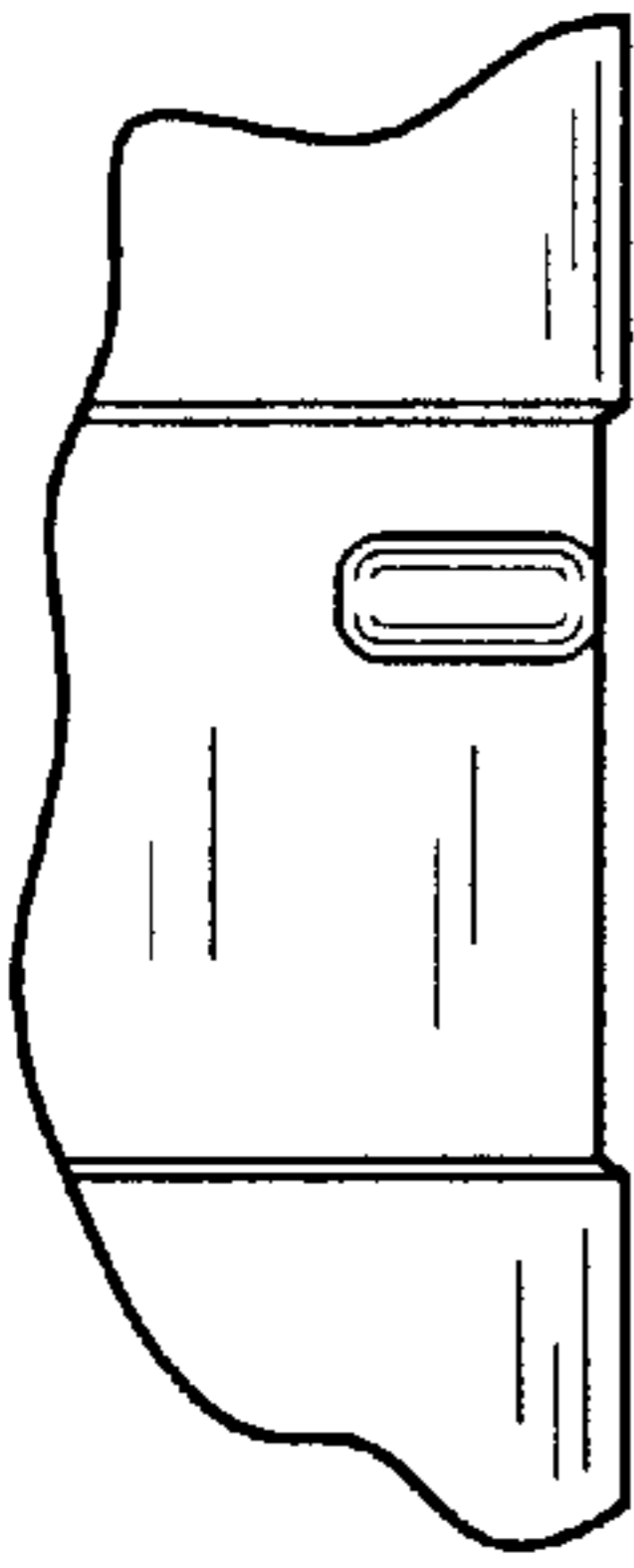

FIG. 21

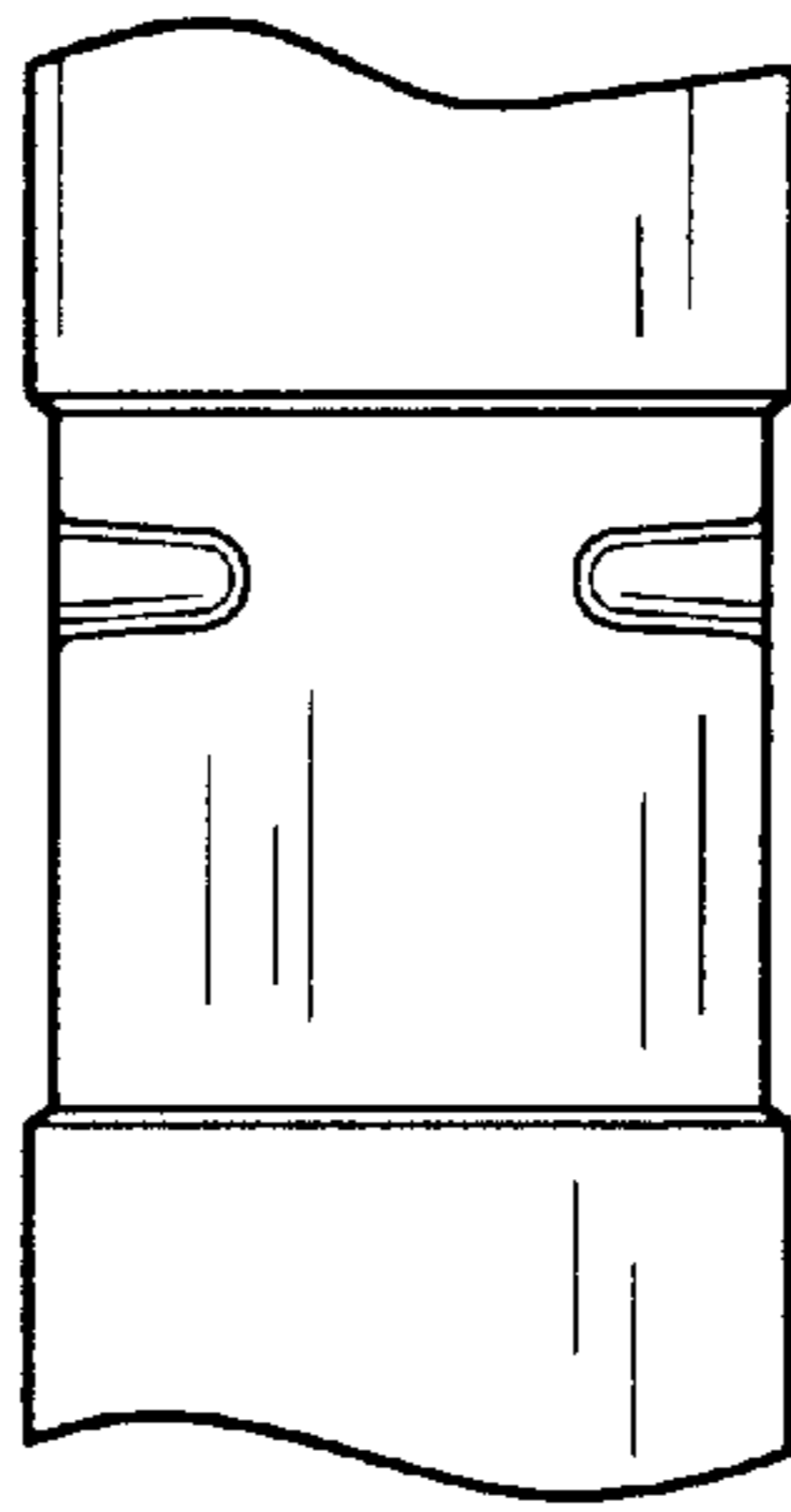

FIG. 22

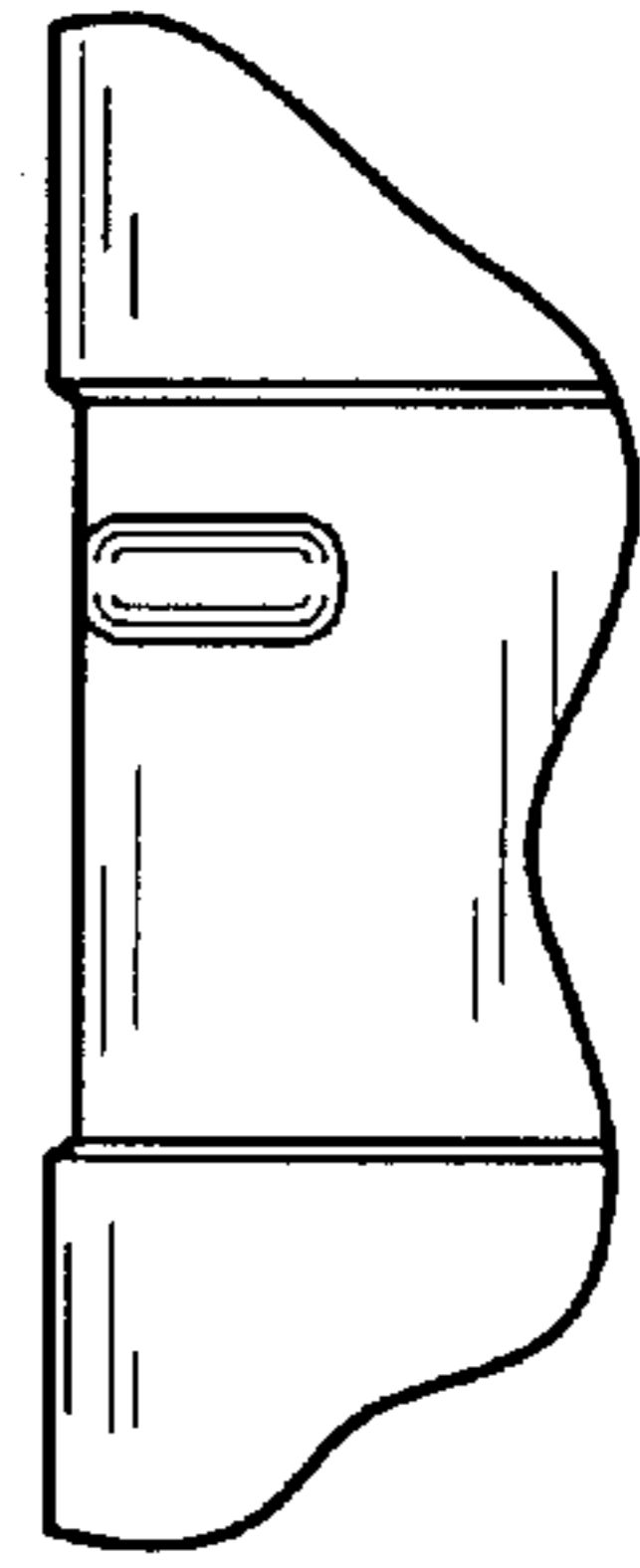

FIG. 23

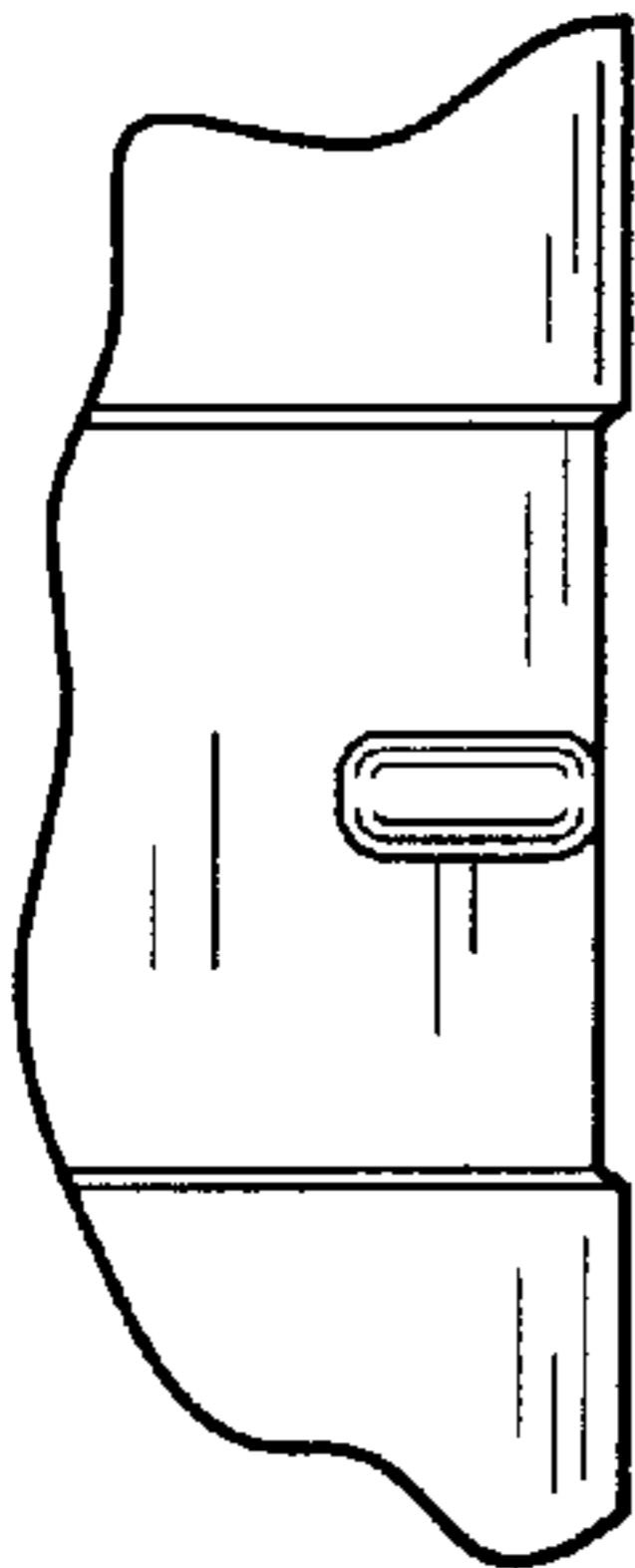

FIG. 24

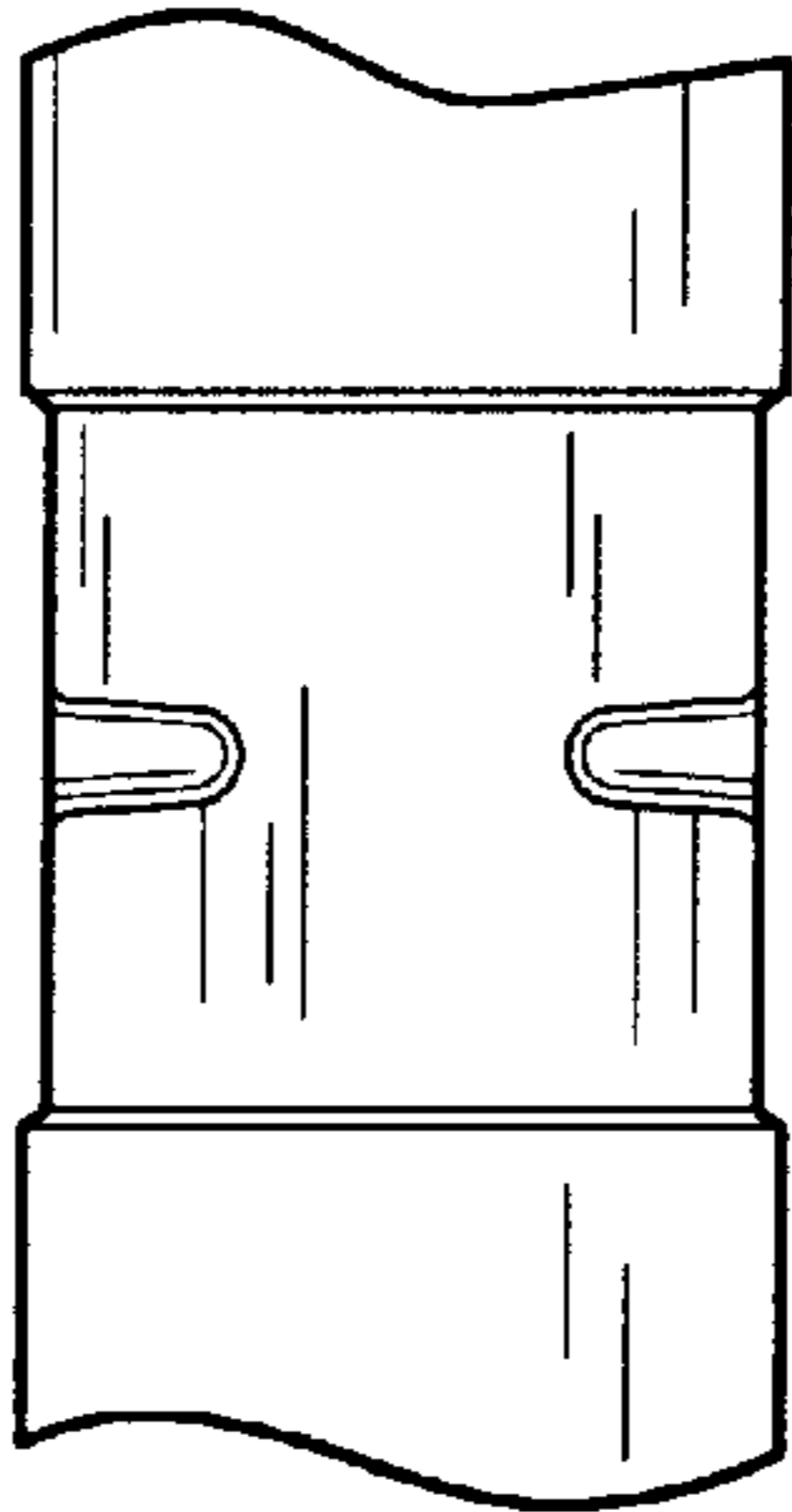

FIG. 25

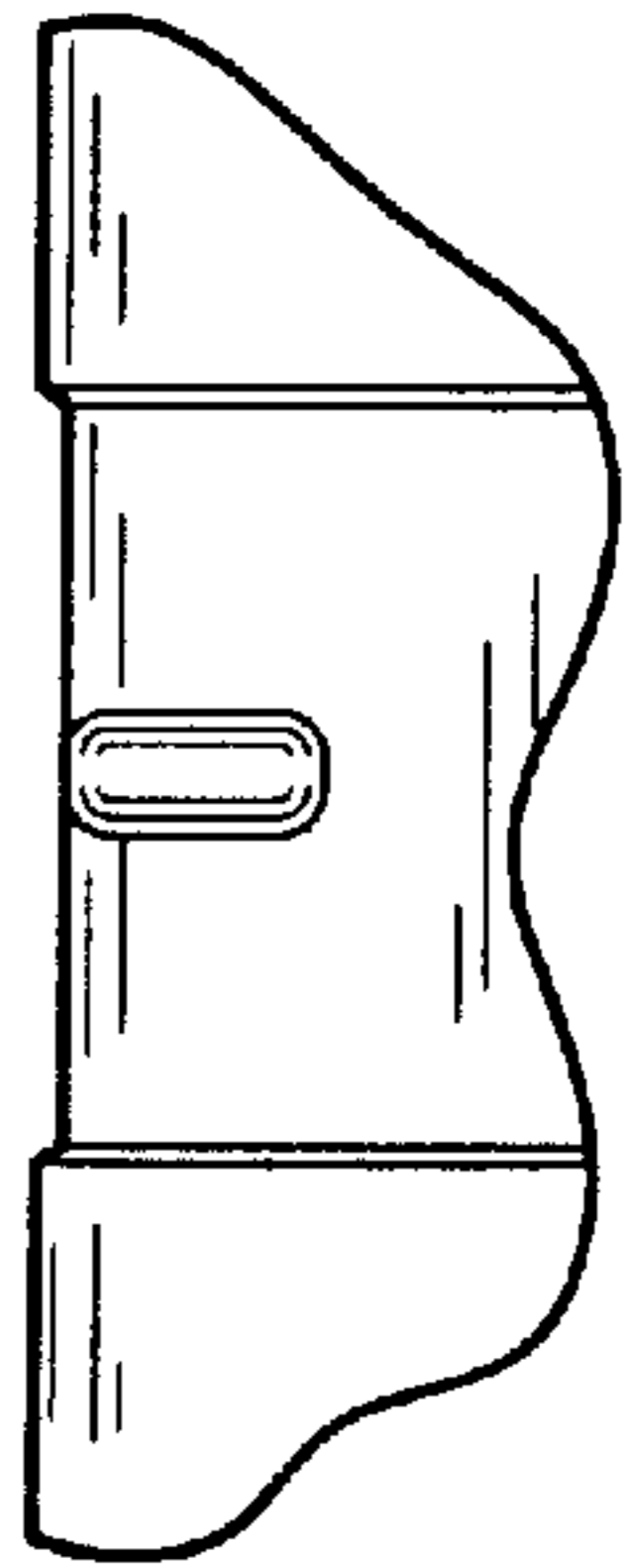

FIG. 26

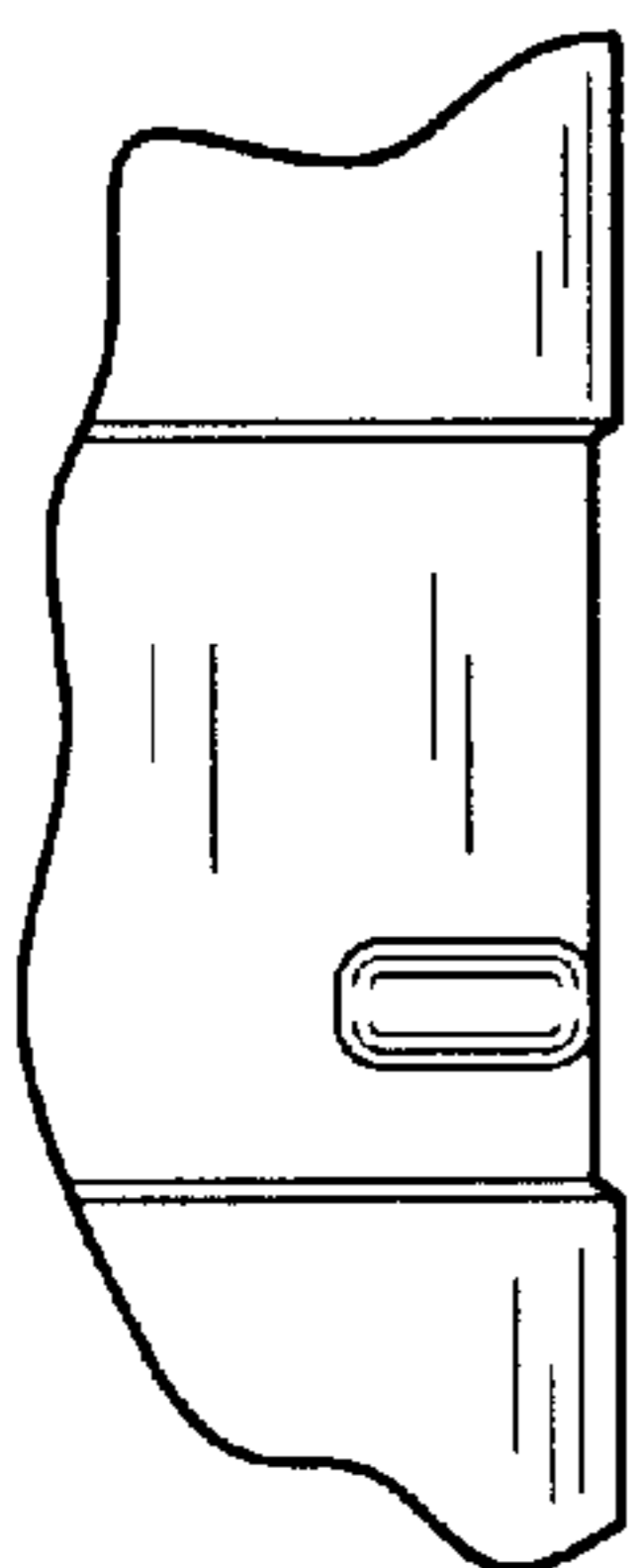

FIG. 27

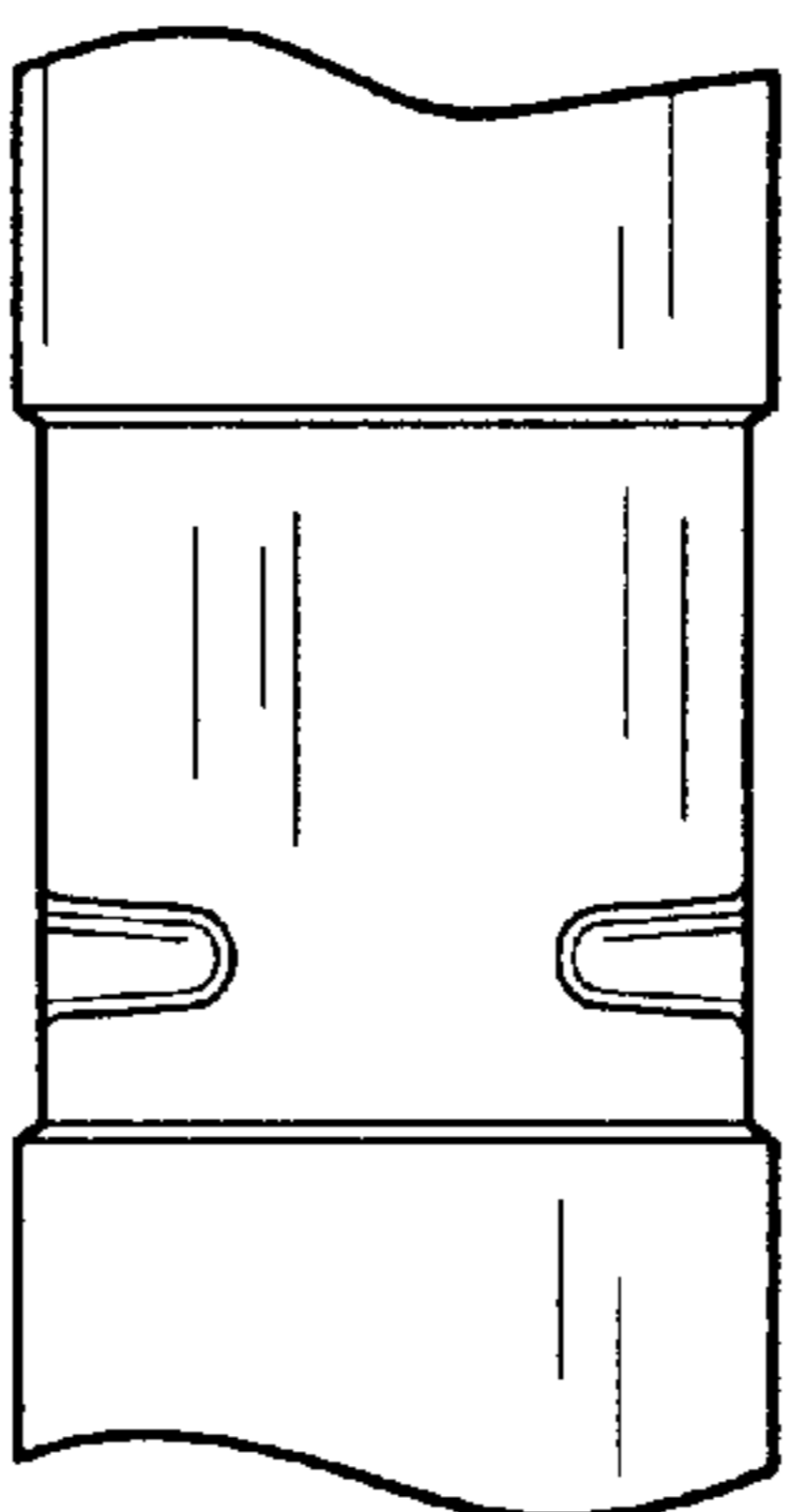

FIG. 28

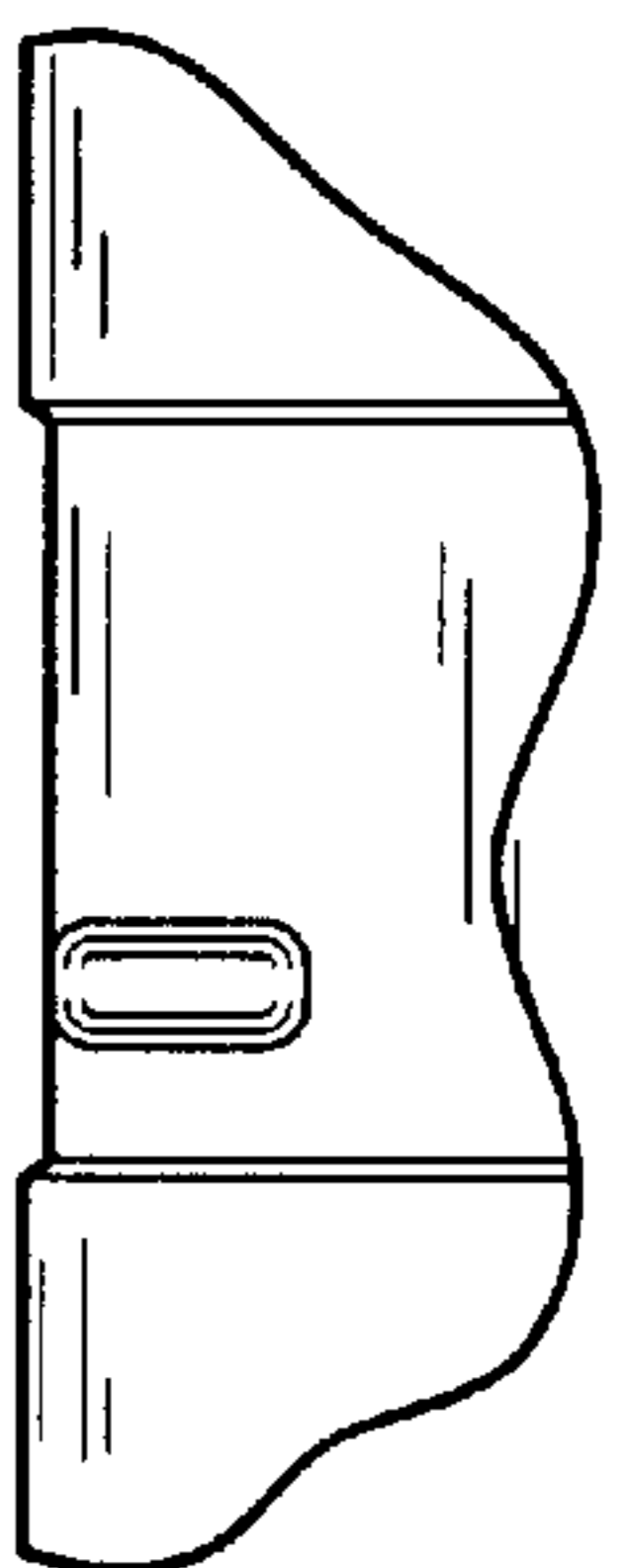

FIG. 29

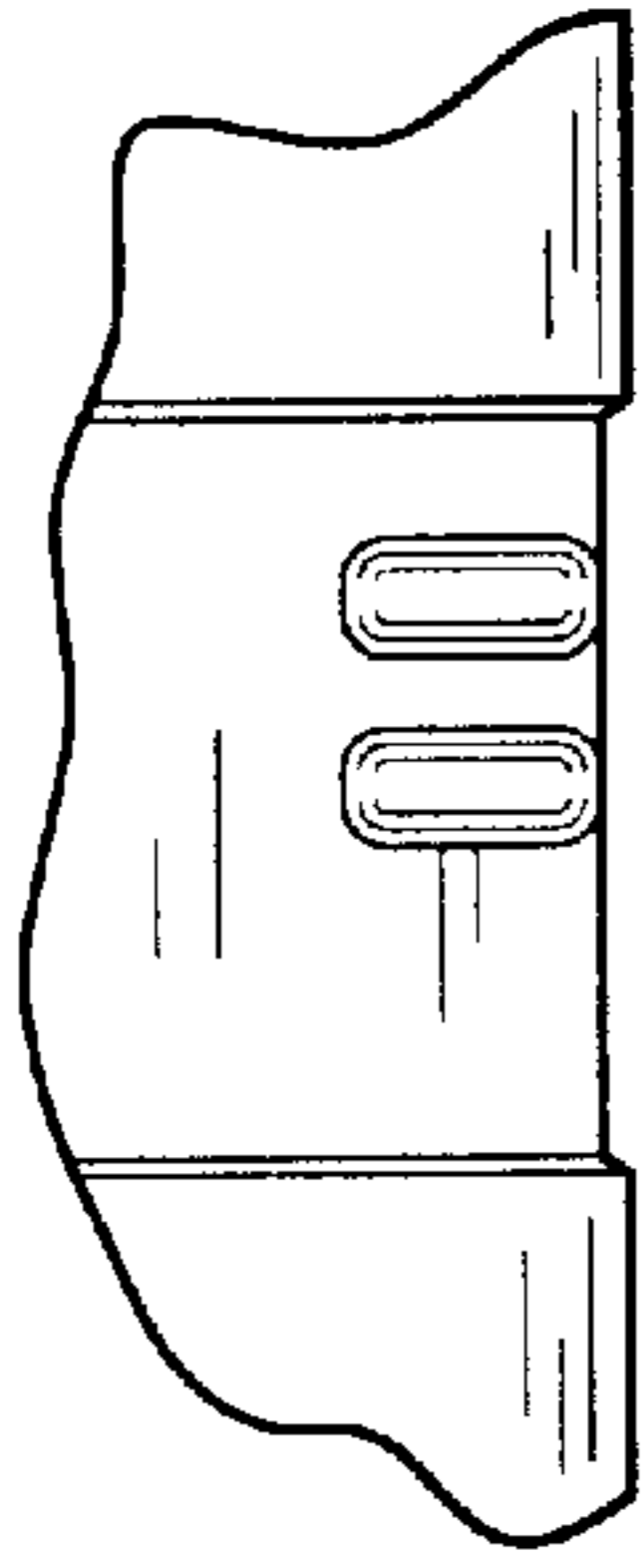

FIG. 30

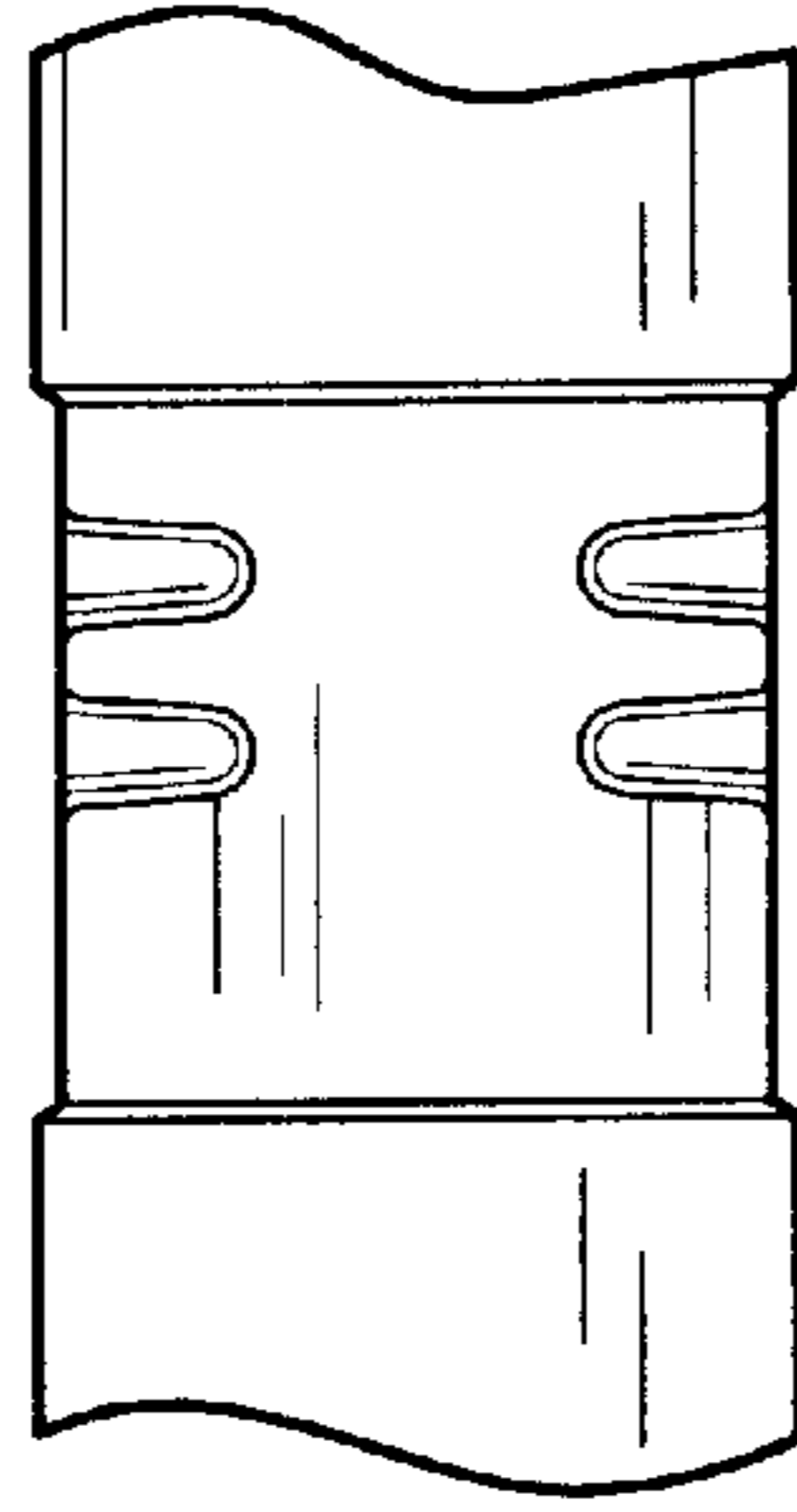

FIG. 31

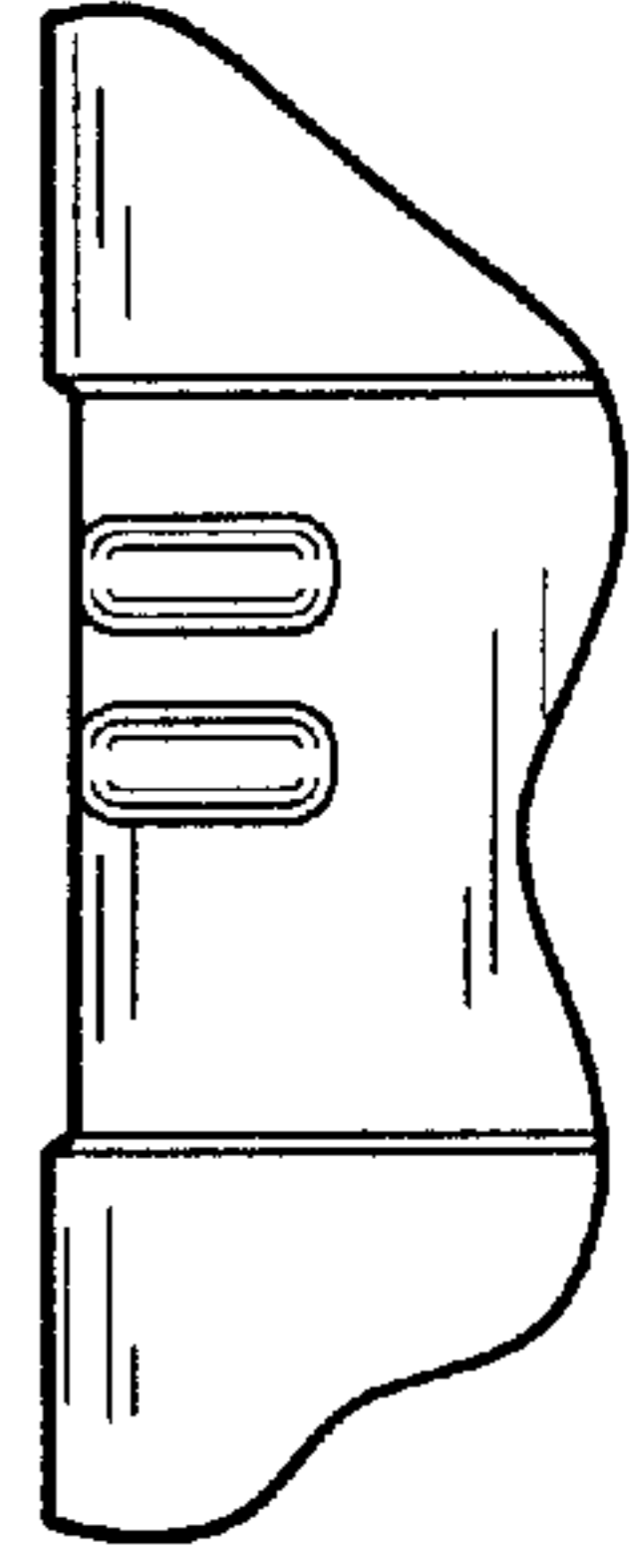

FIG. 32

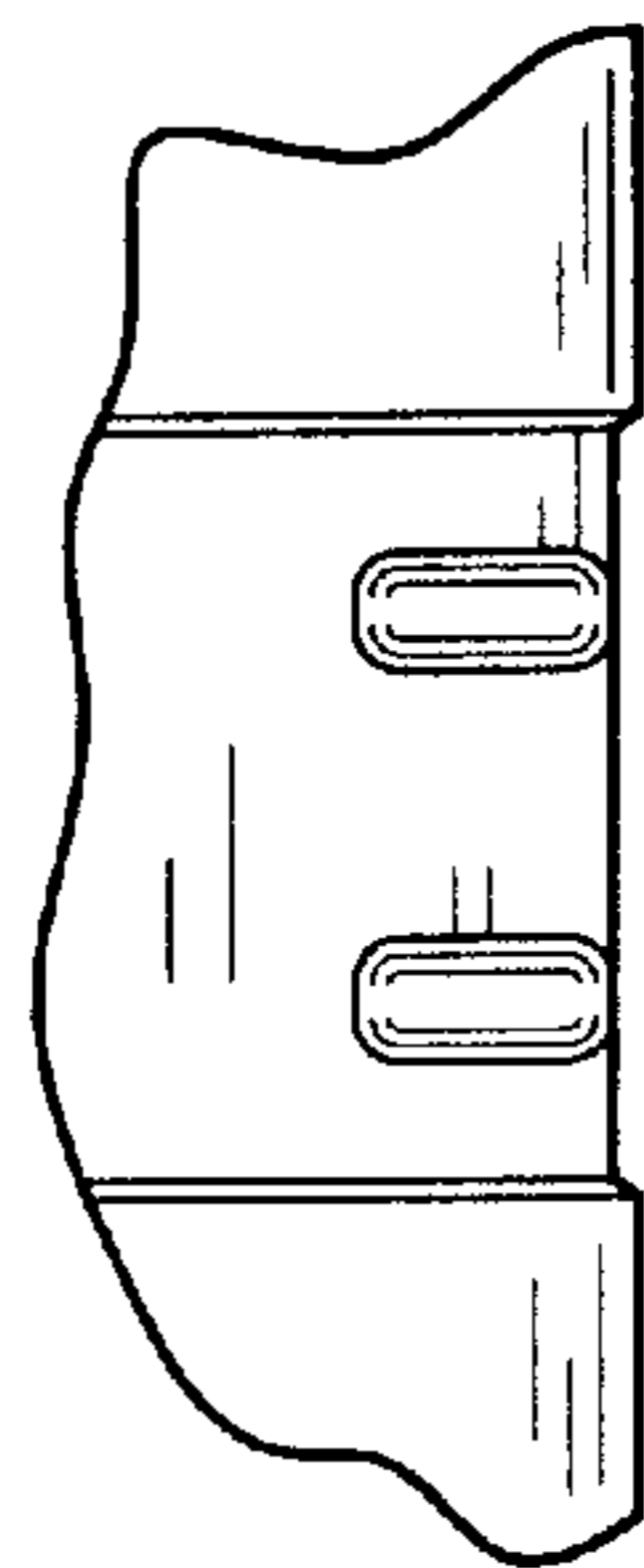

FIG. 33

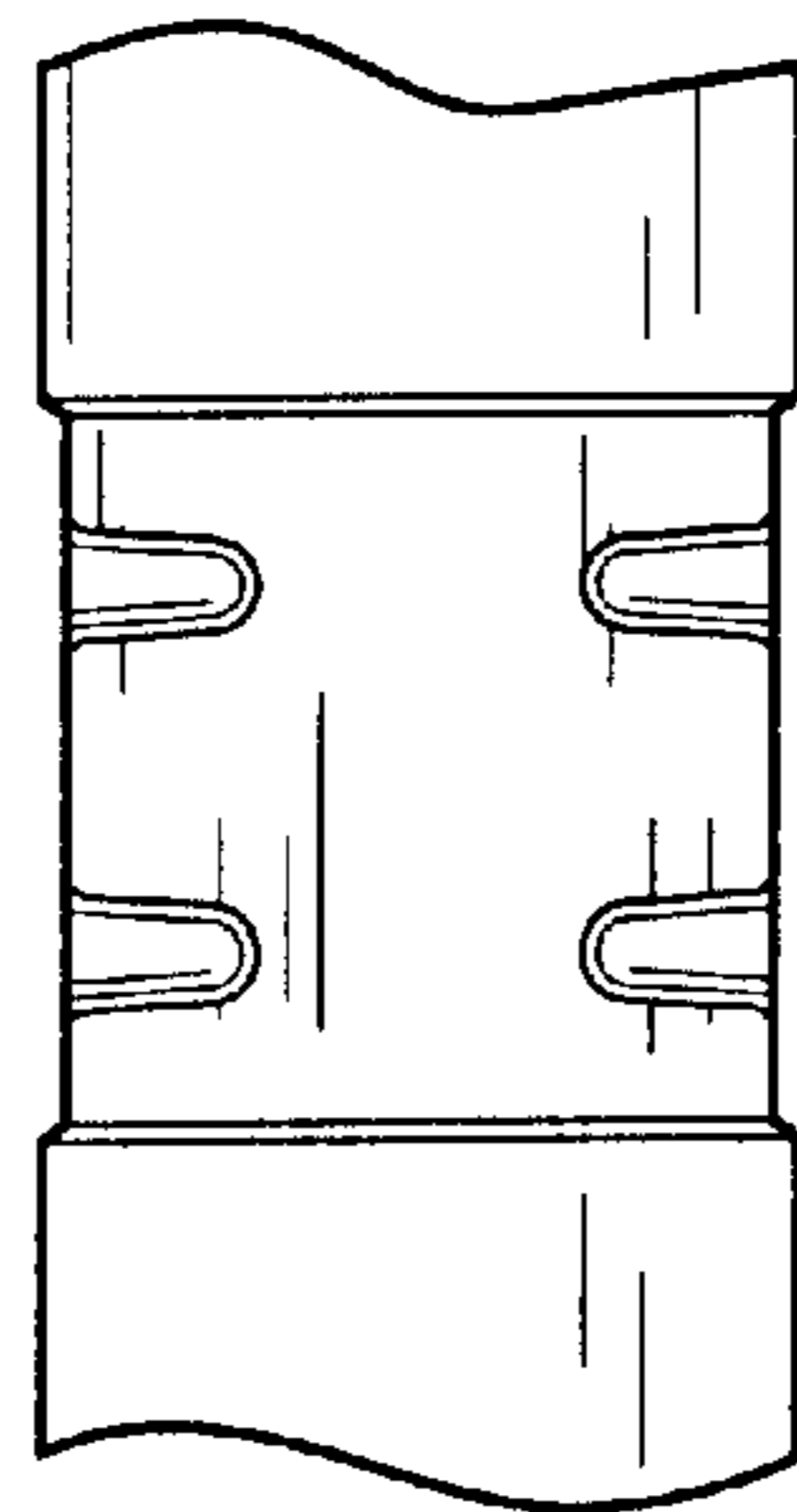

FIG. 34

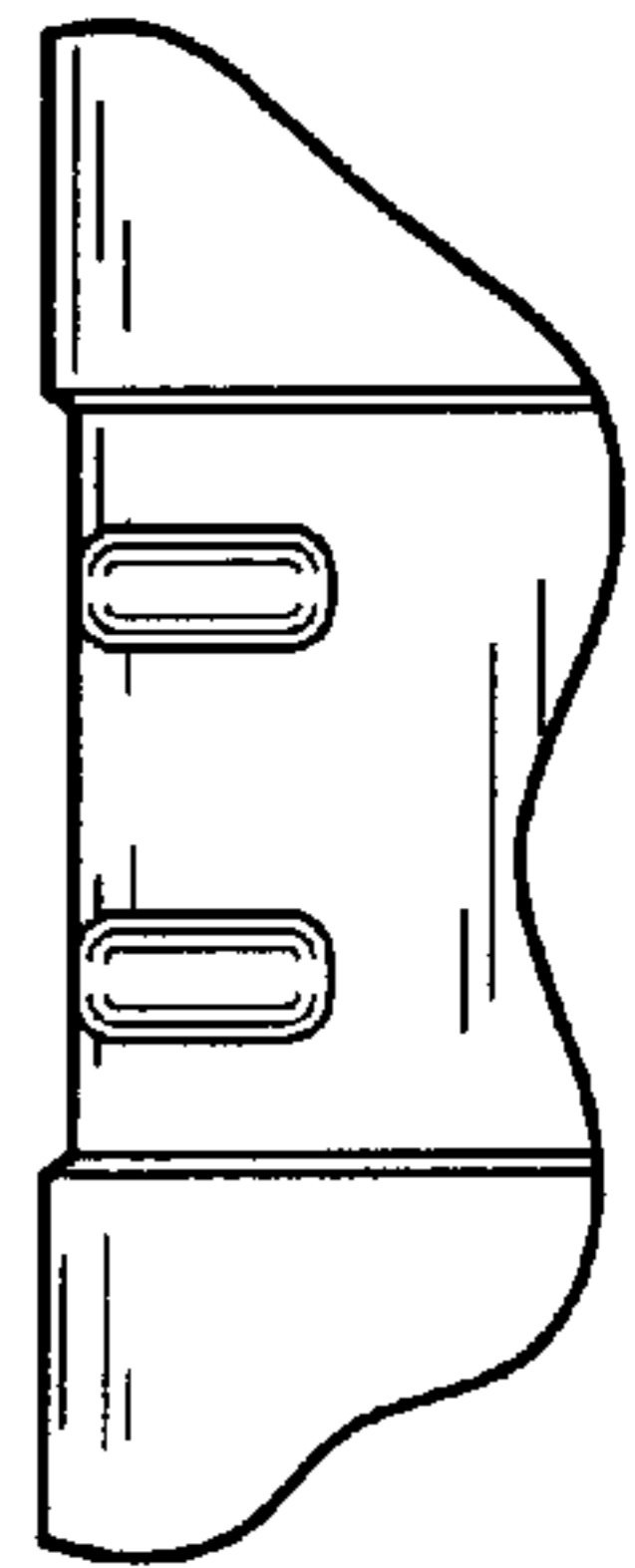

FIG. 35

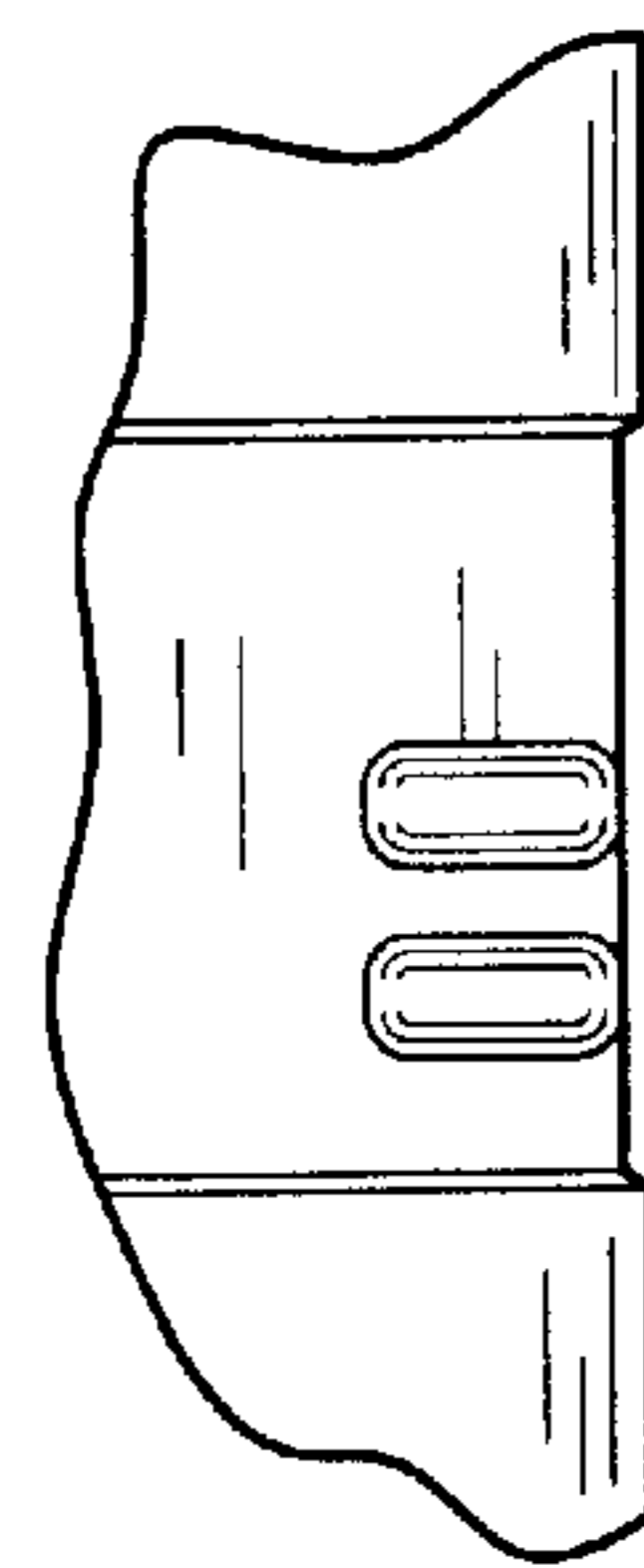

FIG. 36

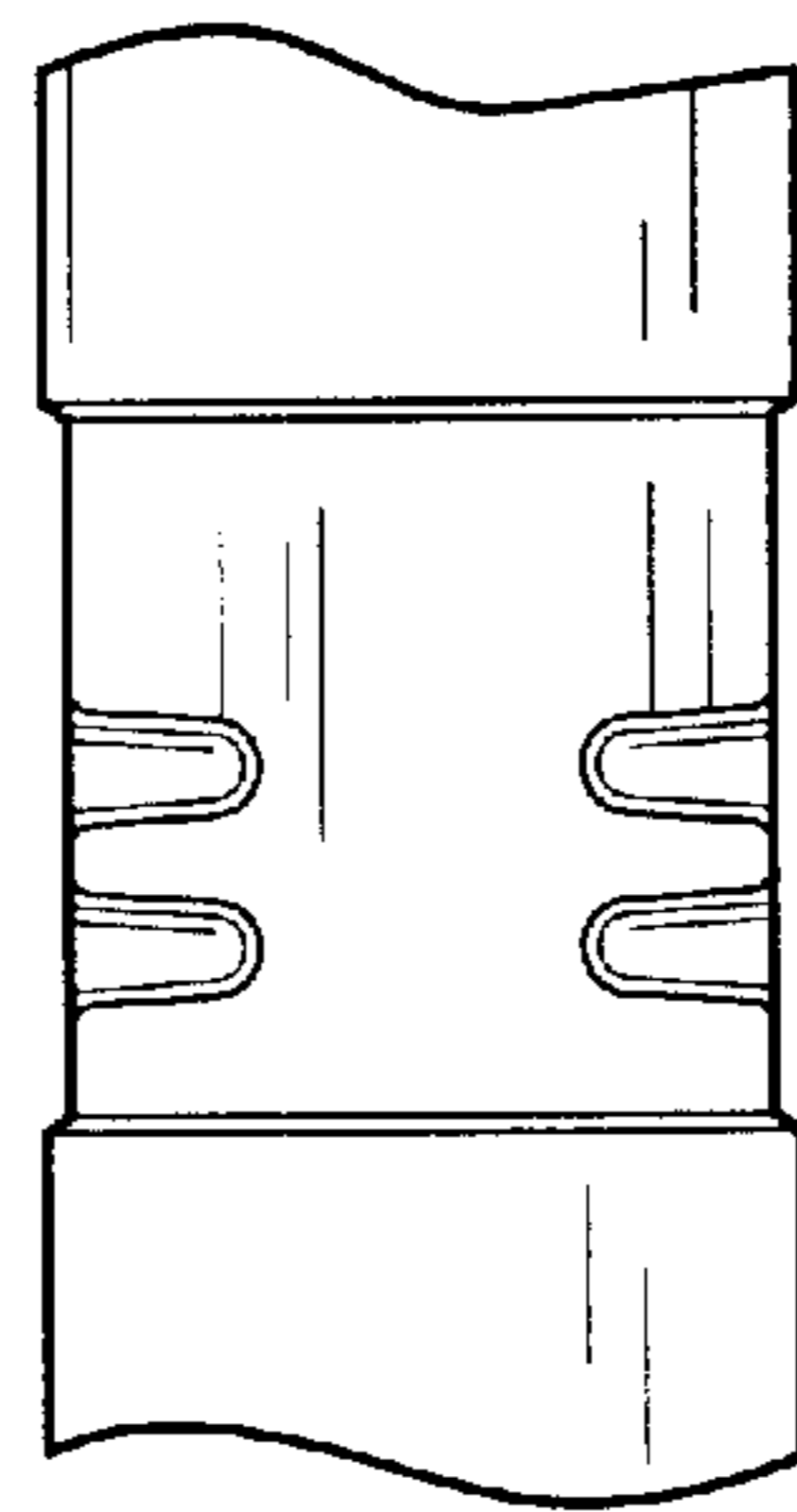

FIG. 37

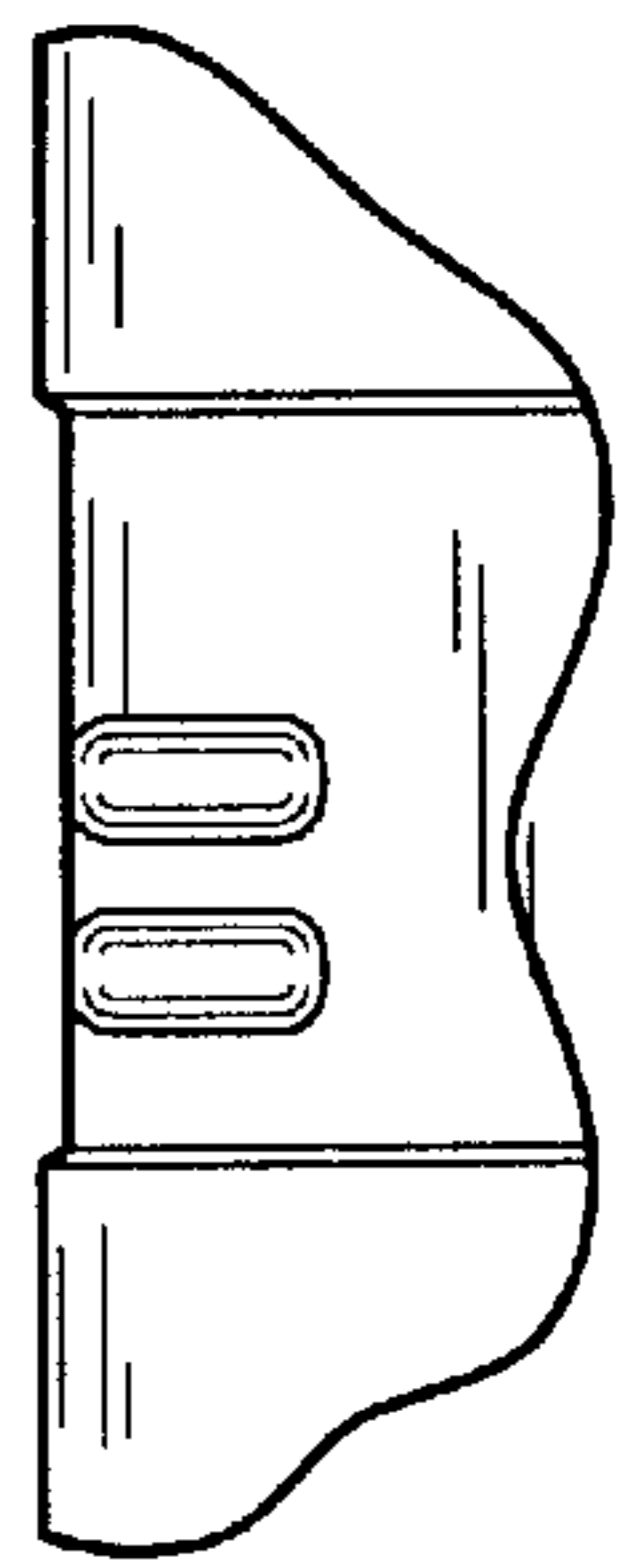

FIG. 38