



US00D467530S

(12) **United States Design Patent**
Ioka et al.

(10) **Patent No.:** **US D467,530 S**

(45) **Date of Patent:** **** Dec. 24, 2002**

(54) **ELECTROMAGNETIC POWDER BRAKE**

6,244,394 B1 * 6/2001 Gutierrez et al. 188/72.8
6,318,513 B1 * 11/2001 Dietrich et al. 188/72.7

(75) Inventors: **Kouichi Ioka**, Tokyo (JP); **Fumio Ono**,
Tokyo (JP); **Yoshiharu Kobayashi**,
Tokyo (JP)

FOREIGN PATENT DOCUMENTS

JP 629221 3/1982

(73) Assignee: **Mitsubishi Denki Kabushiki Kaisha**,
Tokyo (JP)

* cited by examiner

(**) Term: **14 Years**

Primary Examiner—Melody N. Brown

(21) Appl. No.: **29/150,209**

(74) *Attorney, Agent, or Firm*—Oblon, Spivak, McClelland,
Maier & Neustadt, P.C.

(22) Filed: **Nov. 14, 2001**

(57) **CLAIM**

(30) **Foreign Application Priority Data**

The ornamental design for an electromagnetic powder
brake, as shown and described.

Jun. 29, 2001 (JP) 2001-019061

DESCRIPTION

(51) **LOC (7) Cl.** **12-16**

FIG. 1 is a front, top and left side perspective view of an
electromagnetic powder brake, showing our new design;
FIG. 2 is a rear, top and left side perspective view thereof;
FIG. 3 is a front elevational view thereof;
FIG. 4 is a rear elevational view thereof;
FIG. 5 is a top plan view thereof;
FIG. 6 is a bottom plan view thereof; and,
FIG. 7 is a right side elevational view thereof, the left side
elevational view is omitted as that is symmetrical to the right
side elevational view thereof.

(52) **U.S. Cl.** **D12/180**

(58) **Field of Search** D12/180; 188/72.2,
188/72.7, 72.8, 70 B, 111, 138, 156, 162;
210/136, 304, 305

(56) **References Cited**

U.S. PATENT DOCUMENTS

D271,292 S * 11/1983 Wilson et al. D12/180
4,974,705 A * 12/1990 Le Pensee 188/138
5,791,442 A * 8/1998 Arnold 188/138

1 Claim, 4 Drawing Sheets

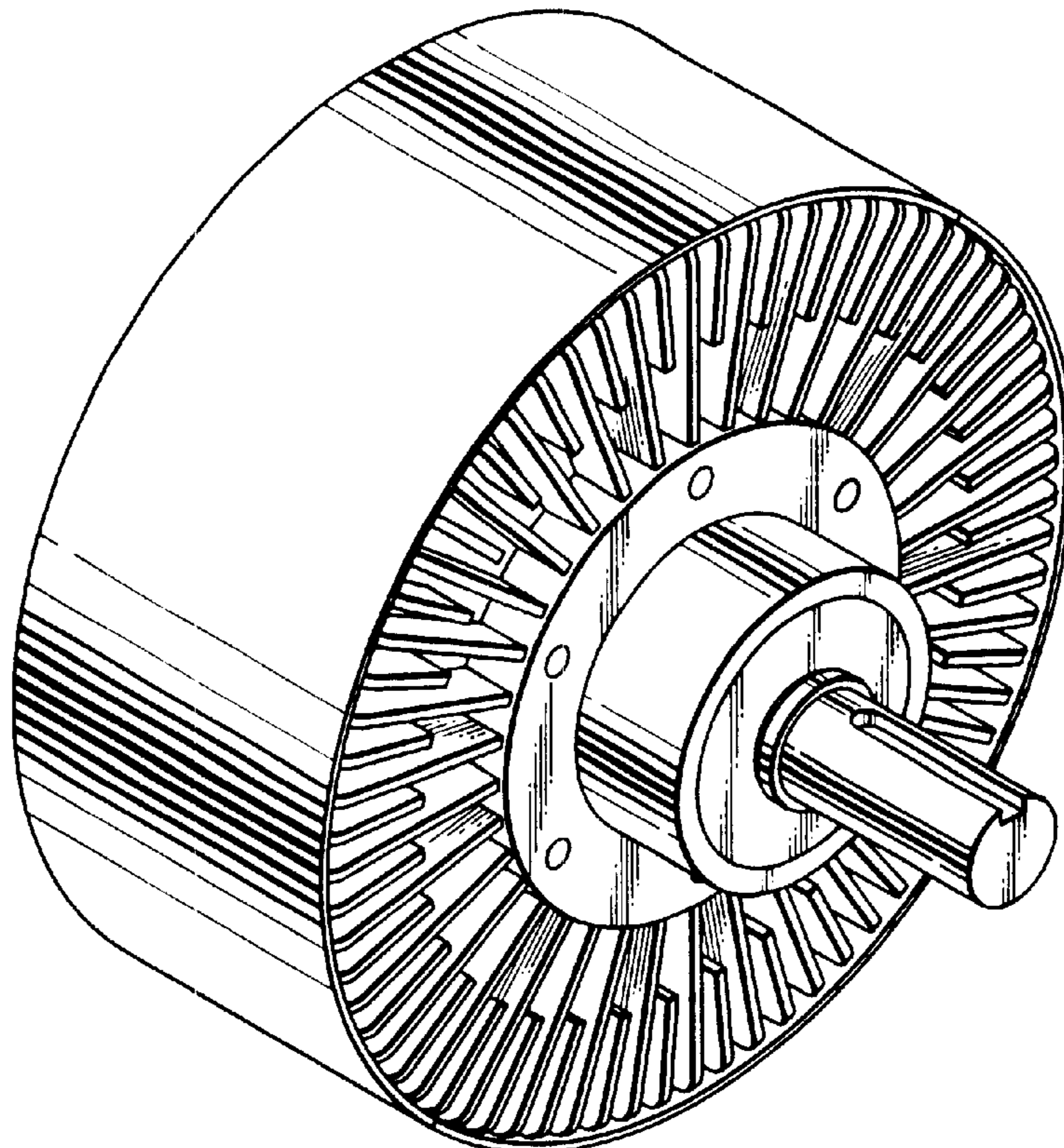

FIG. 1

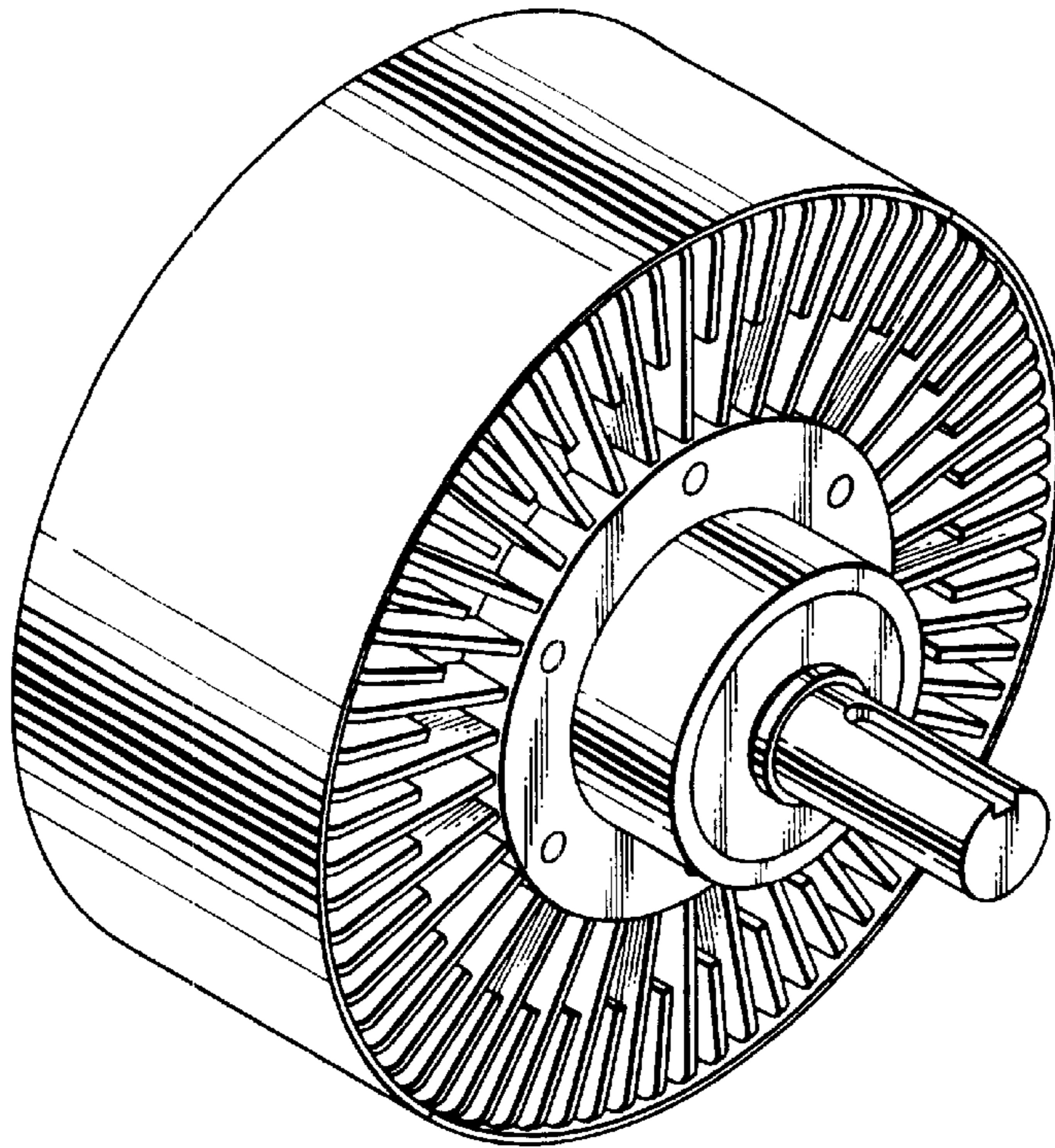

FIG. 2

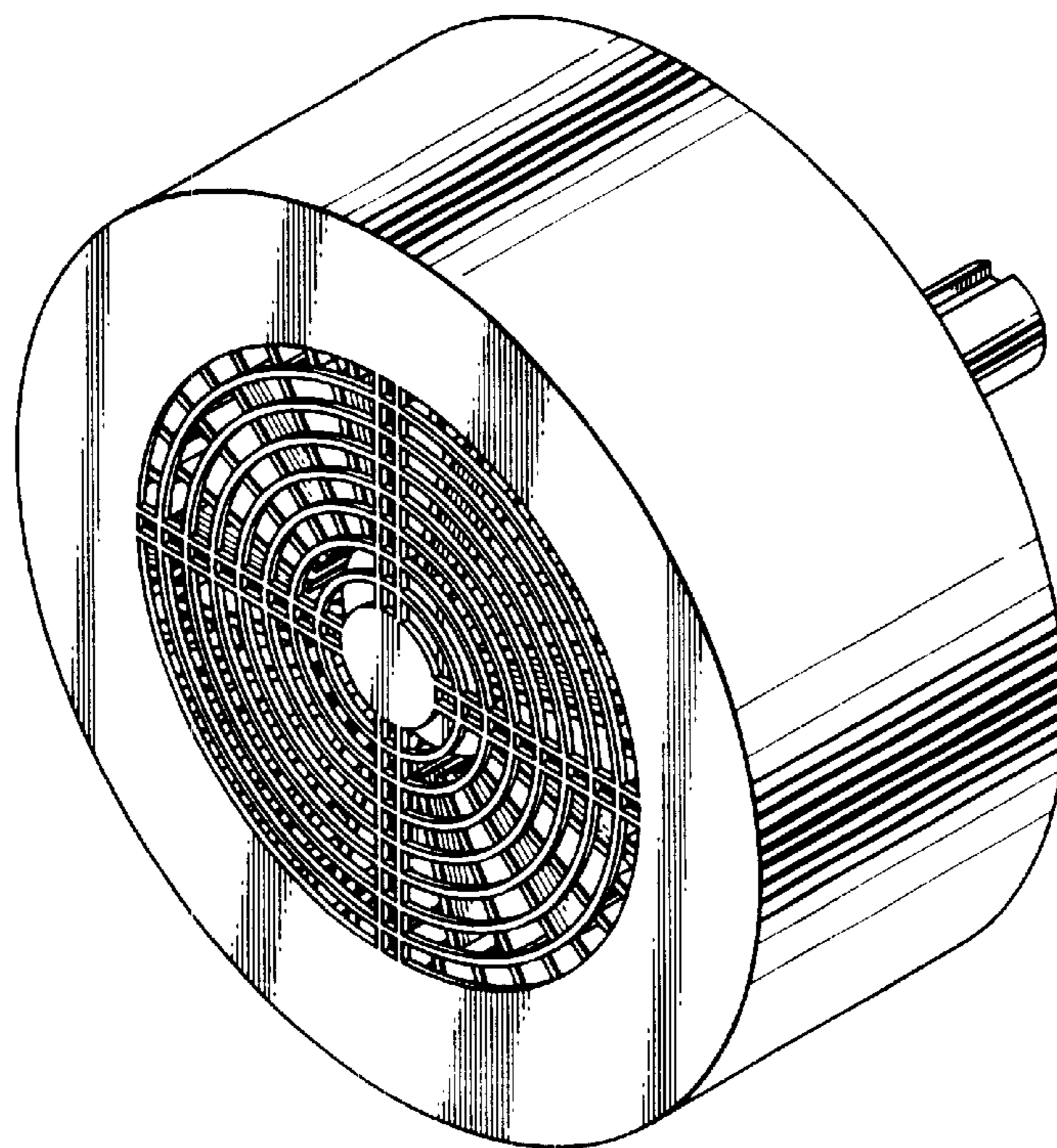

FIG. 3

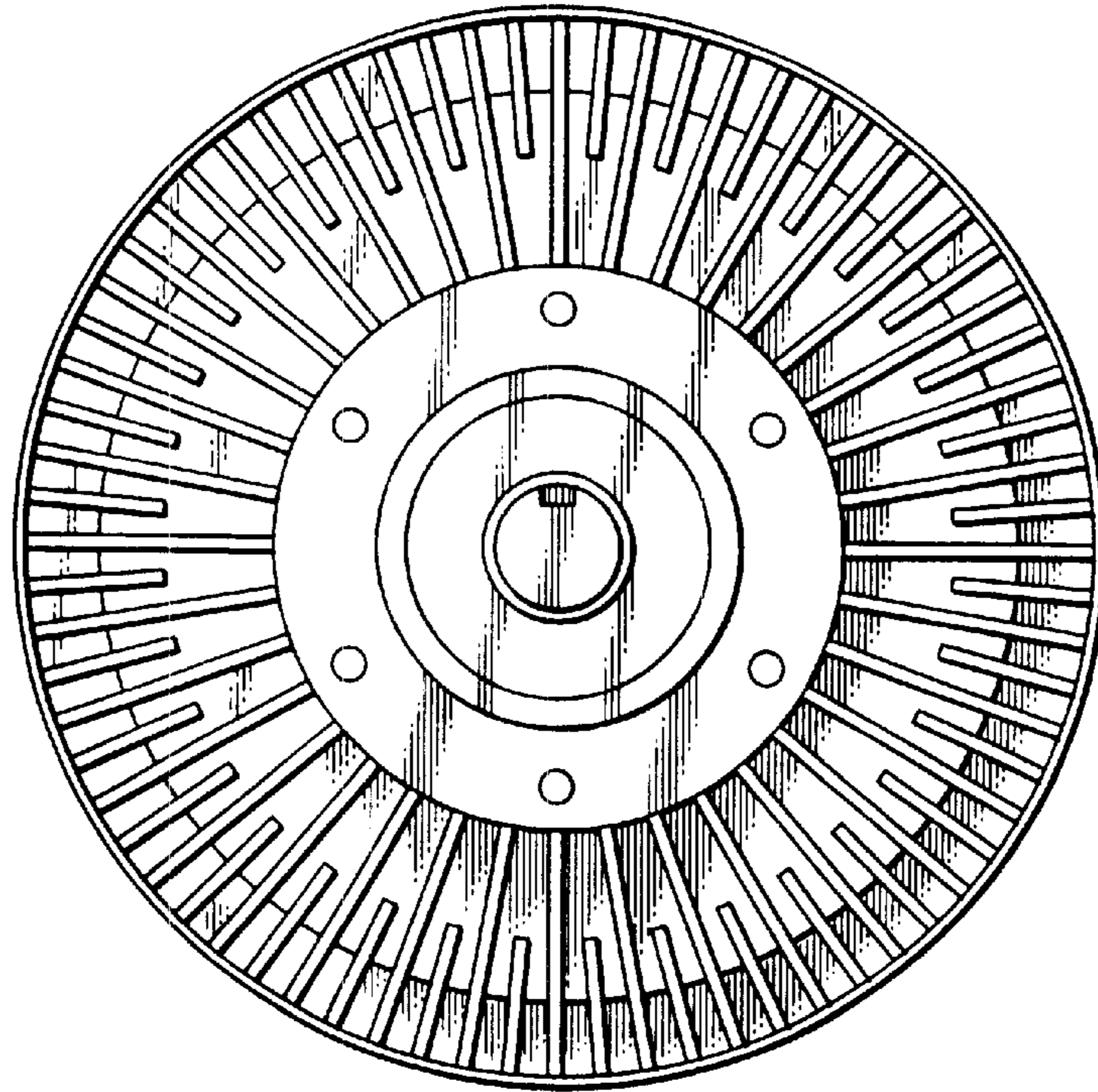

FIG. 4

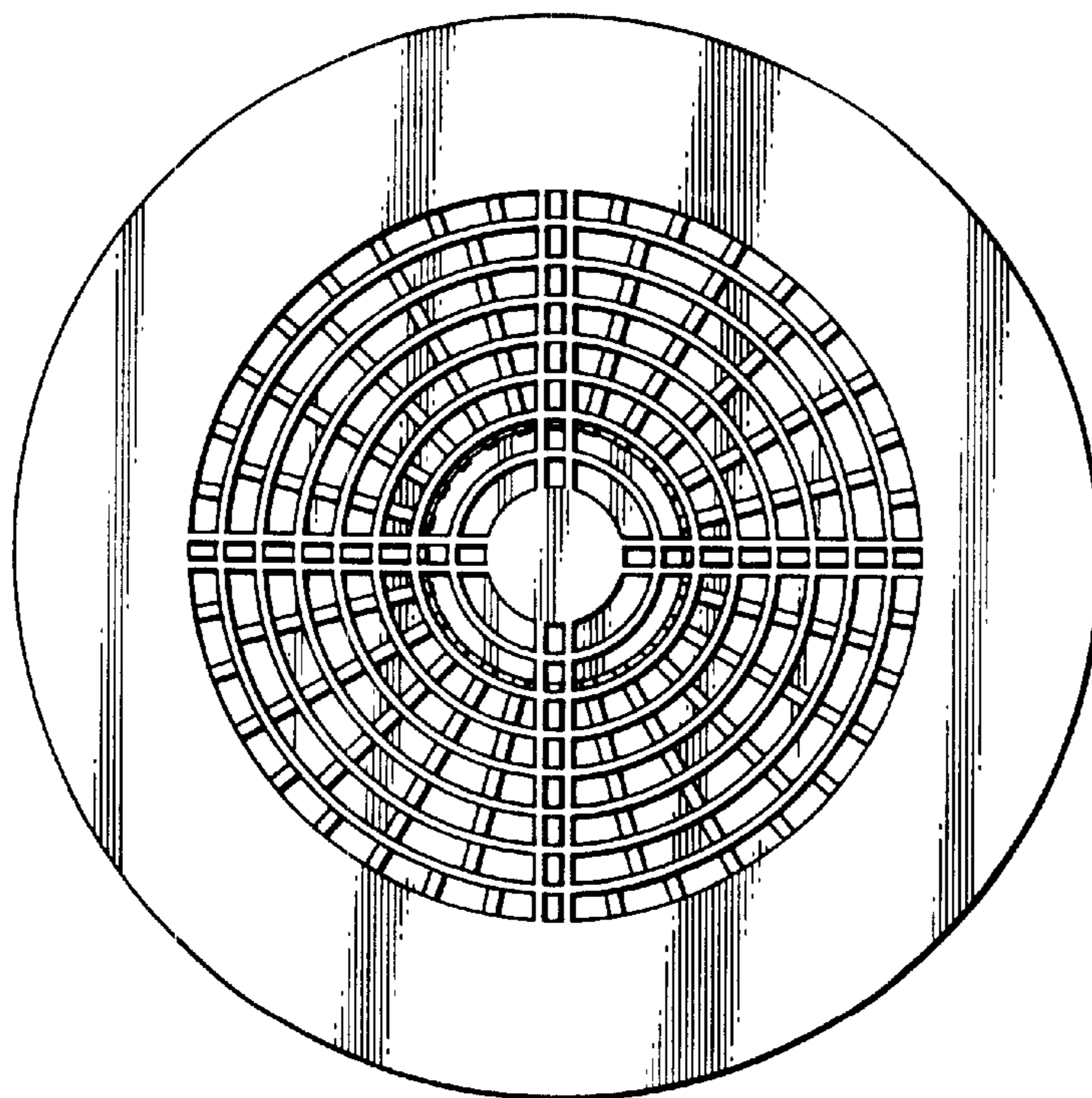

FIG.5

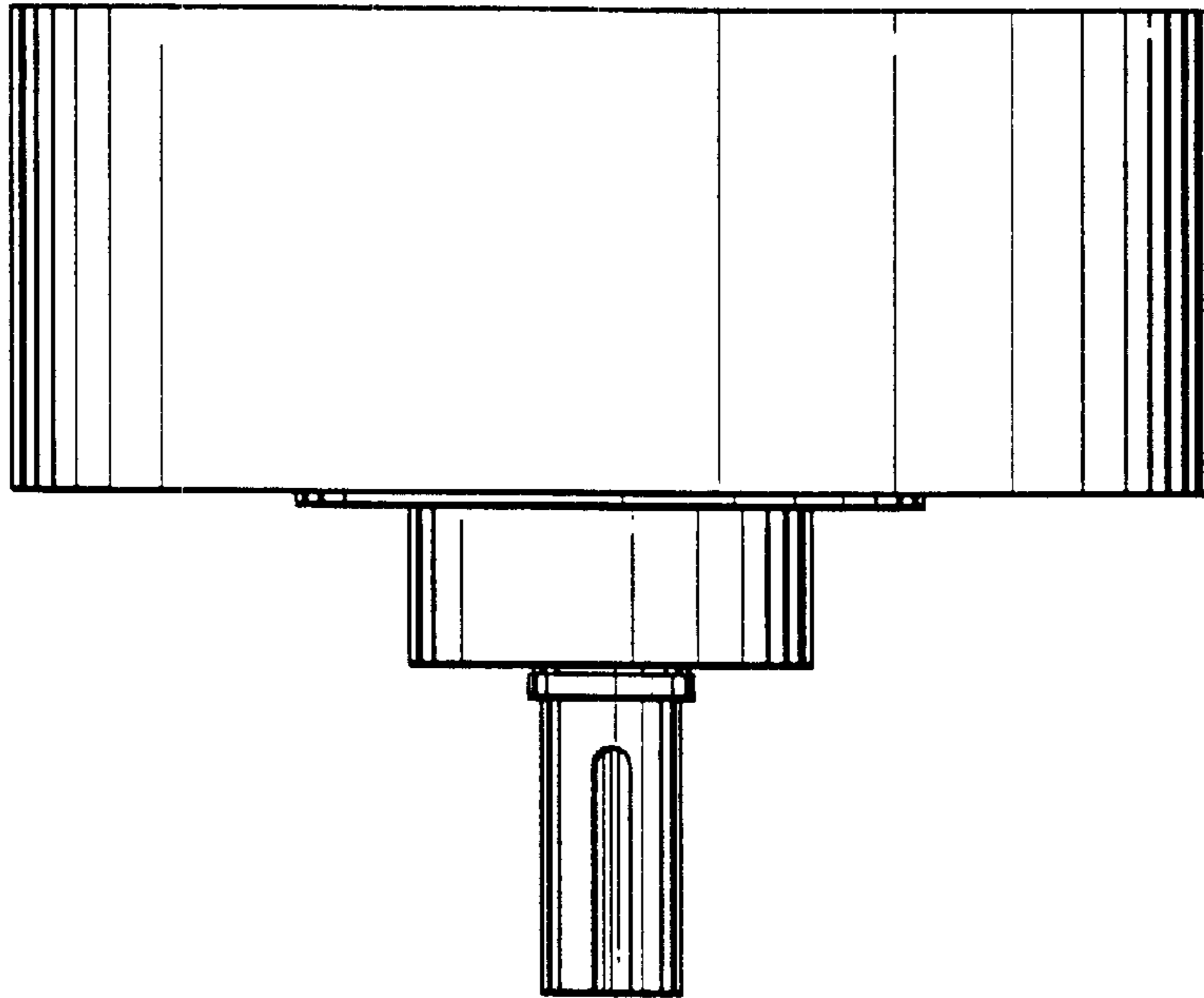

FIG.6

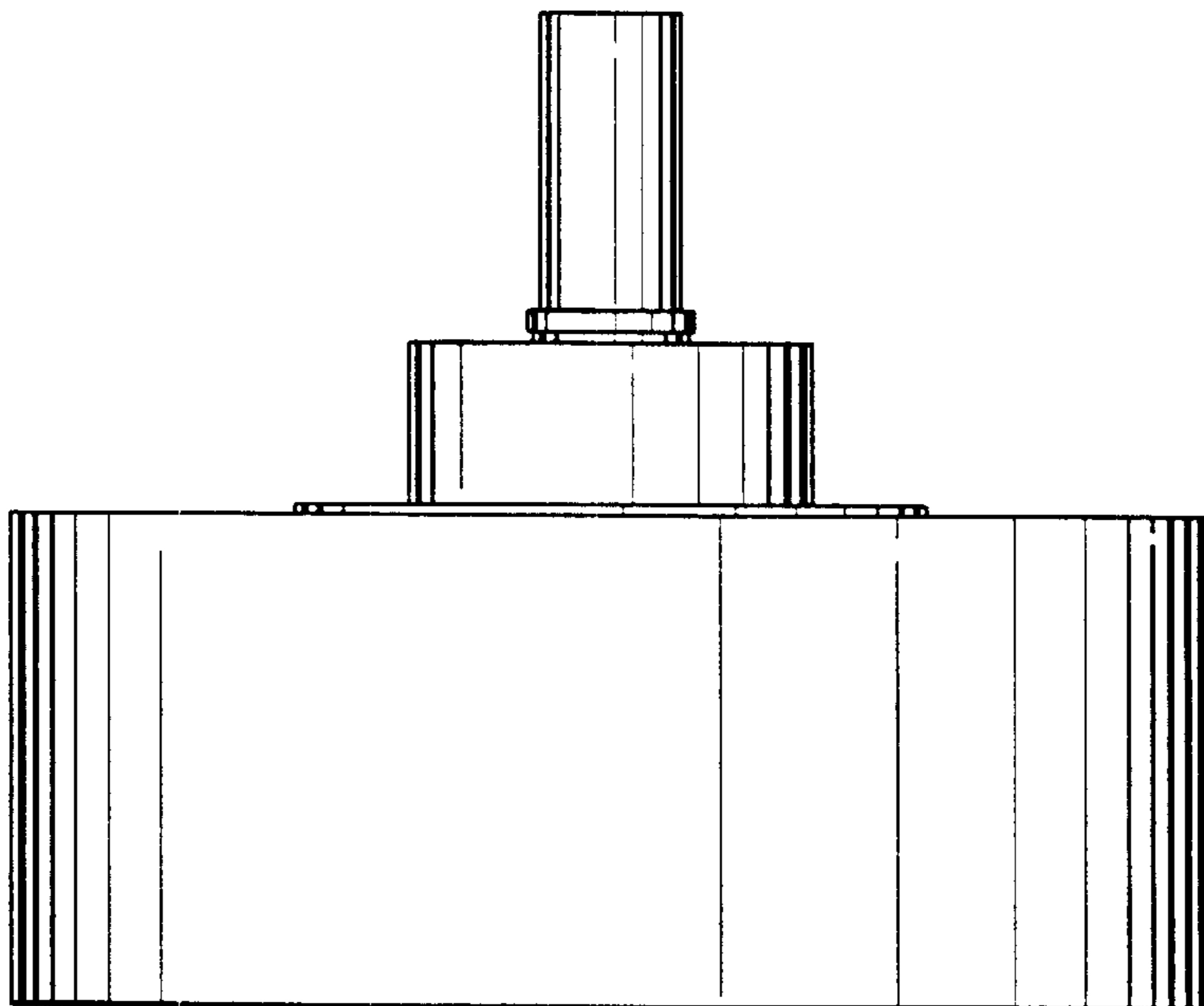

FIG. 7

