



US00D467524S

(12) **United States Design Patent**  
**Desmond**

(10) **Patent No.:** **US D467,524 S**

(45) **Date of Patent:** **\*\* Dec. 24, 2002**

(54) **VEHICLE EXTERIOR**

(75) Inventor: **Michael A. Desmond**, Long Beach, CA (US)

(73) Assignee: **Mitsubishi Jidosha Kogyo Kabushiki Kaisha**, Tokyo (JP)

(\*\*) Term: **14 Years**

(21) Appl. No.: **29/153,453**

(22) Filed: **Jan. 10, 2002**

(51) **LOC (7) Cl.** ..... **12-08**

(52) **U.S. Cl.** ..... **D12/92**

(58) **Field of Search** ..... D12/90-92, 86; 296/185

(56) **References Cited**

**U.S. PATENT DOCUMENTS**

D451,845 S \* 12/2001 Hull et al. .... D12/92

D455,984 S \* 4/2002 Boulay et al. .... D12/92

\* cited by examiner

*Primary Examiner*—Melody N. Brown

(74) *Attorney, Agent, or Firm*—Birch, Stewart, Kolasch & Birch, LLP

(57) **CLAIM**

The ornamental design for a vehicle exterior, as shown and described.

**DESCRIPTION**

FIG. 1 is a right side elevation view of a vehicle exterior showing our new design;

FIG. 2 is a top plan view thereof;

FIG. 3 is a front elevation view thereof;

FIG. 4 is a rear elevation view thereof;

FIG. 5 is a front perspective view thereof; and,

FIG. 6 is a rear perspective view thereof.

The broken lines showing of environmental structure in FIGS. 1, 3, 4, 5, and 6 of the drawings are for illustrative purposes only and form no part of the claimed design.

**1 Claim, 5 Drawing Sheets**

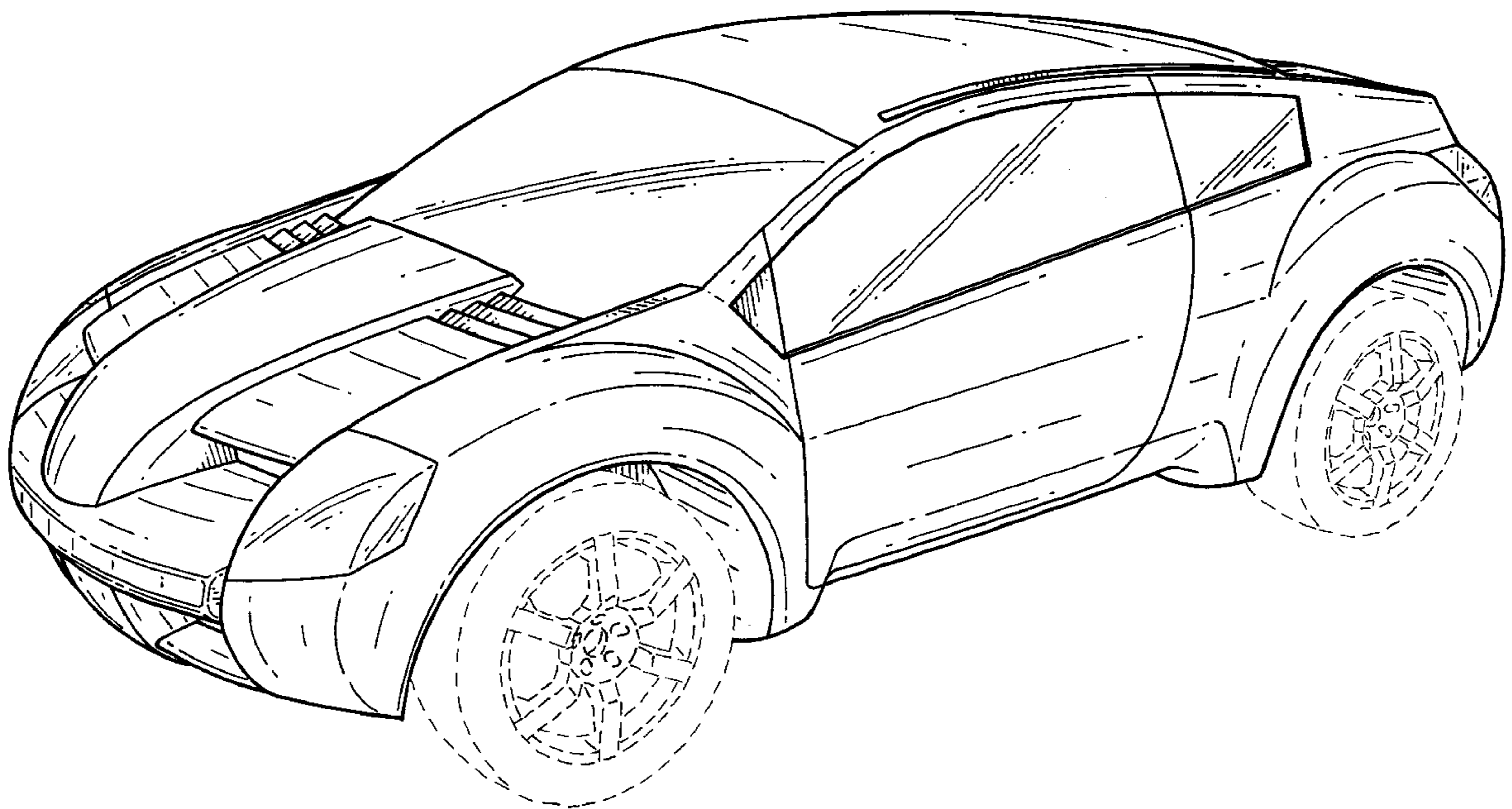

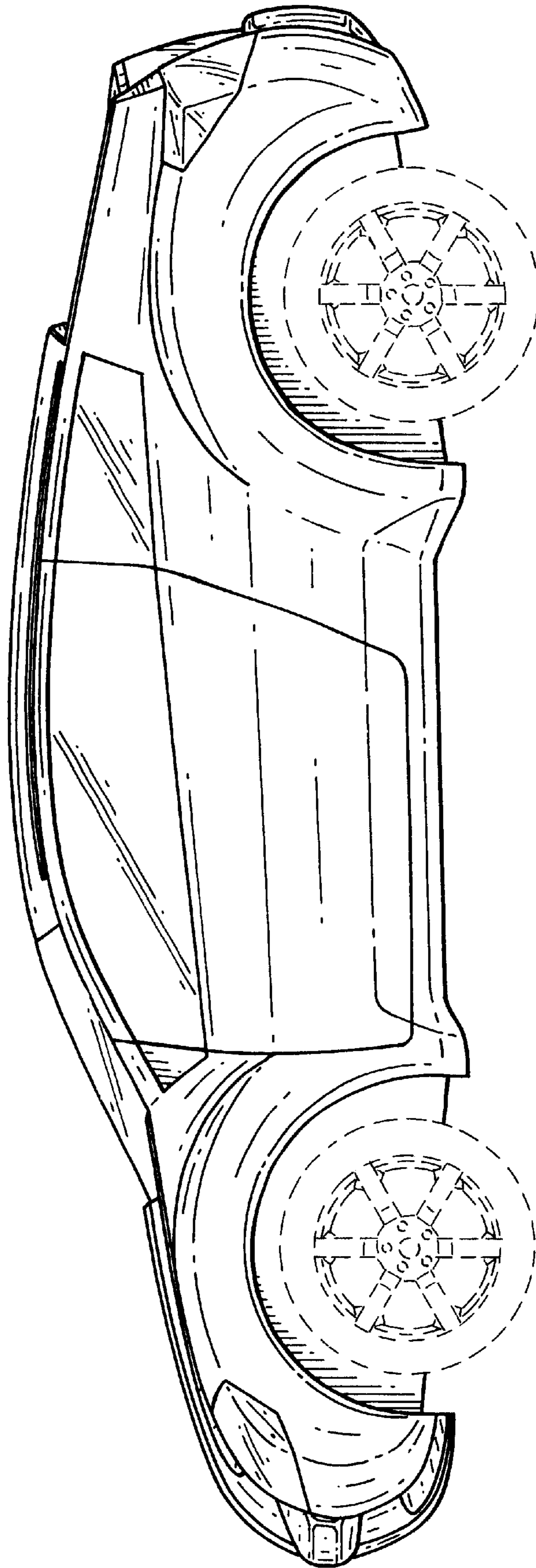

FIG.1

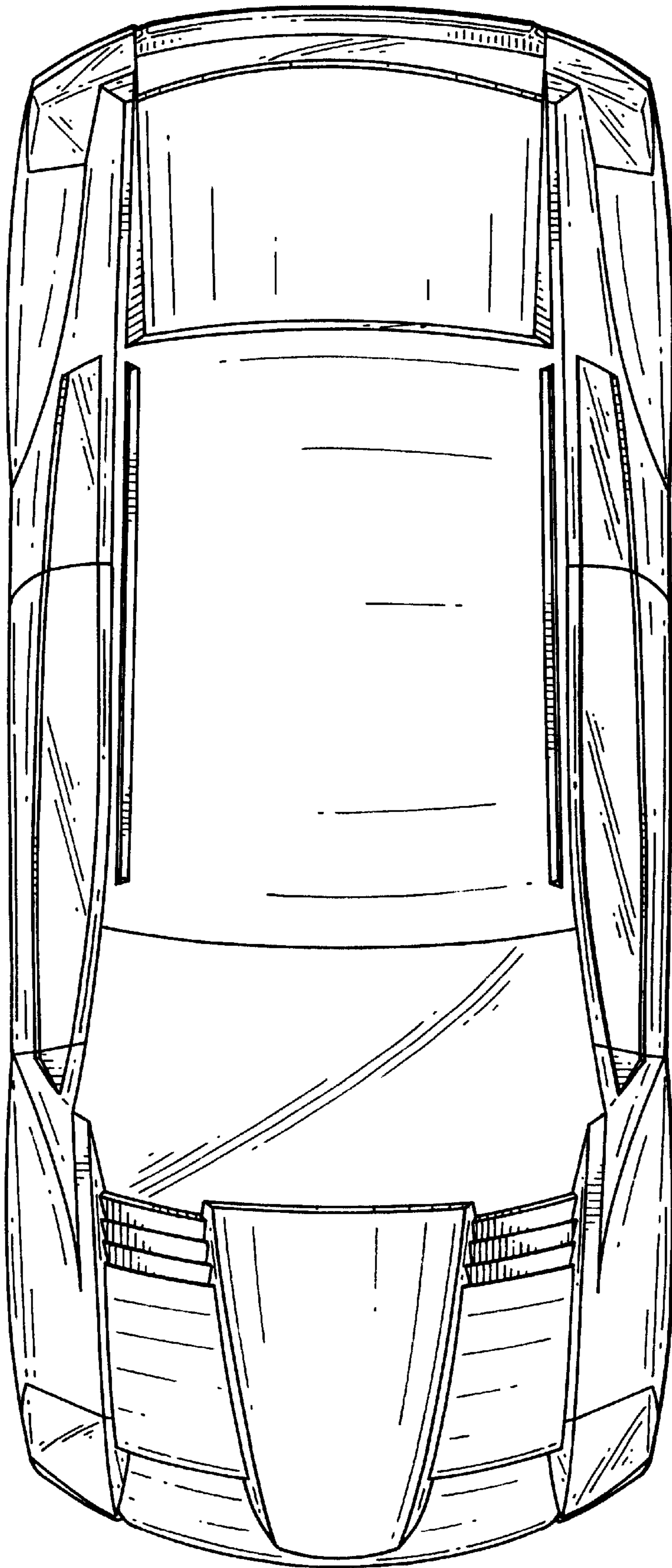

FIG.2

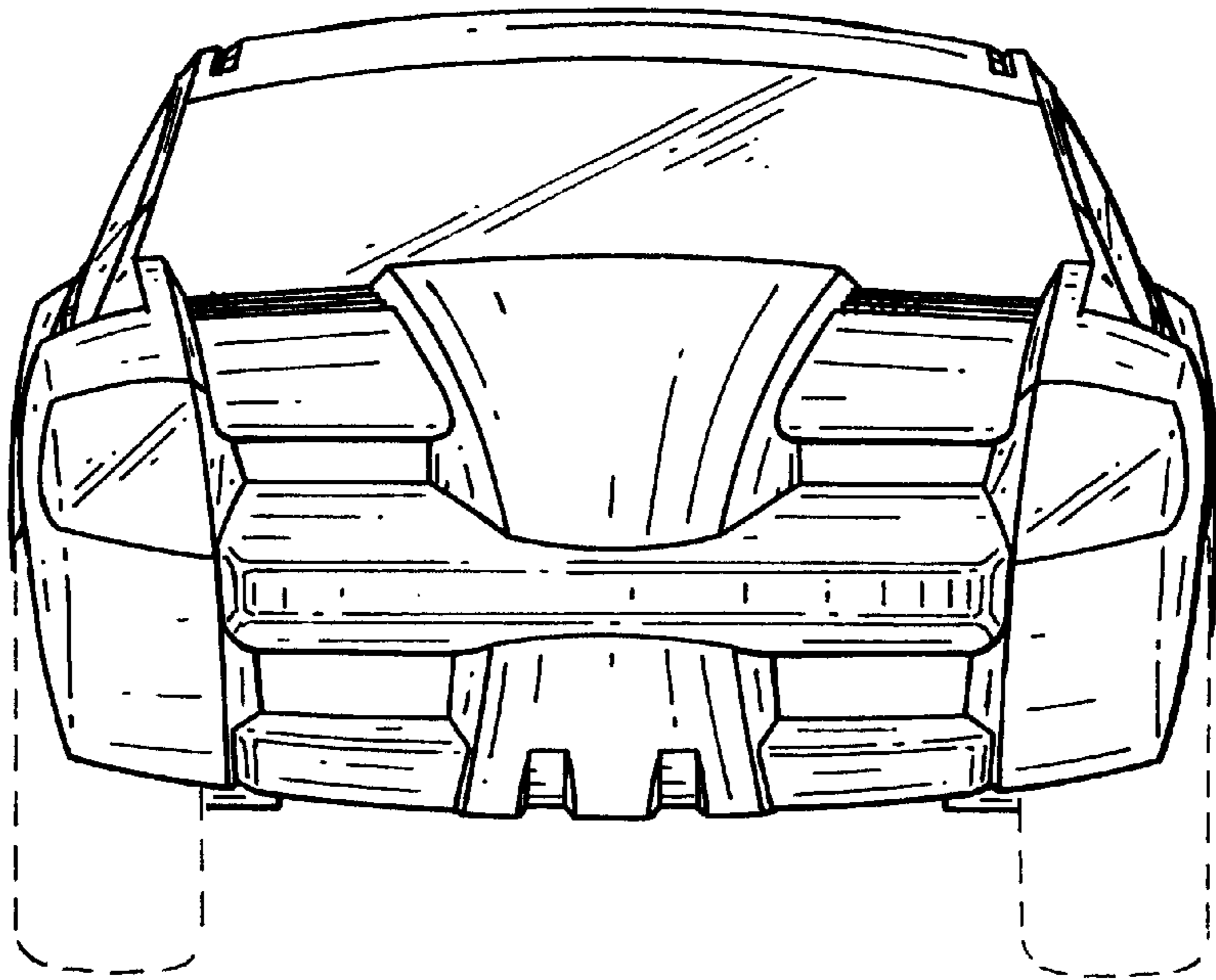

FIG.3

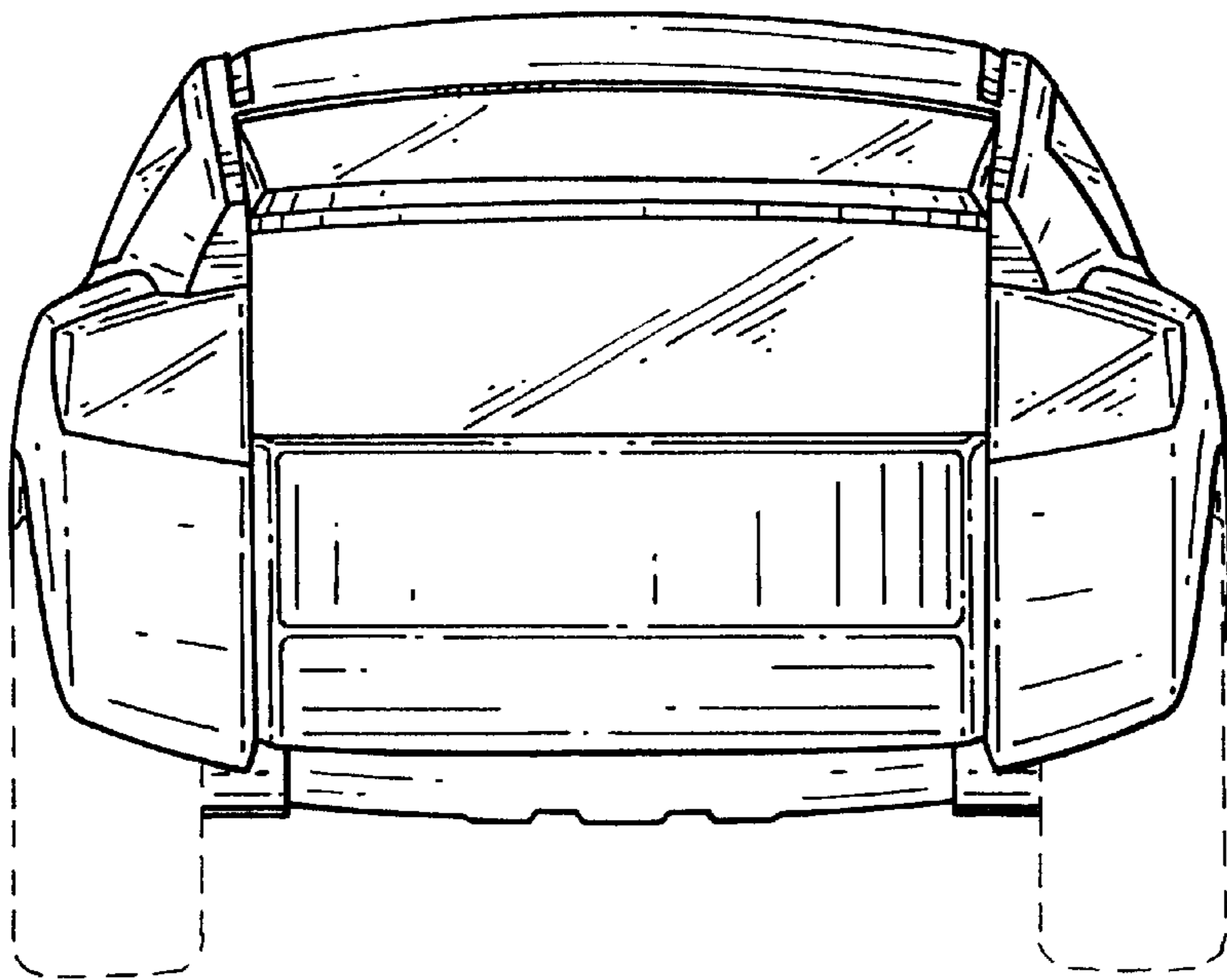

FIG.4

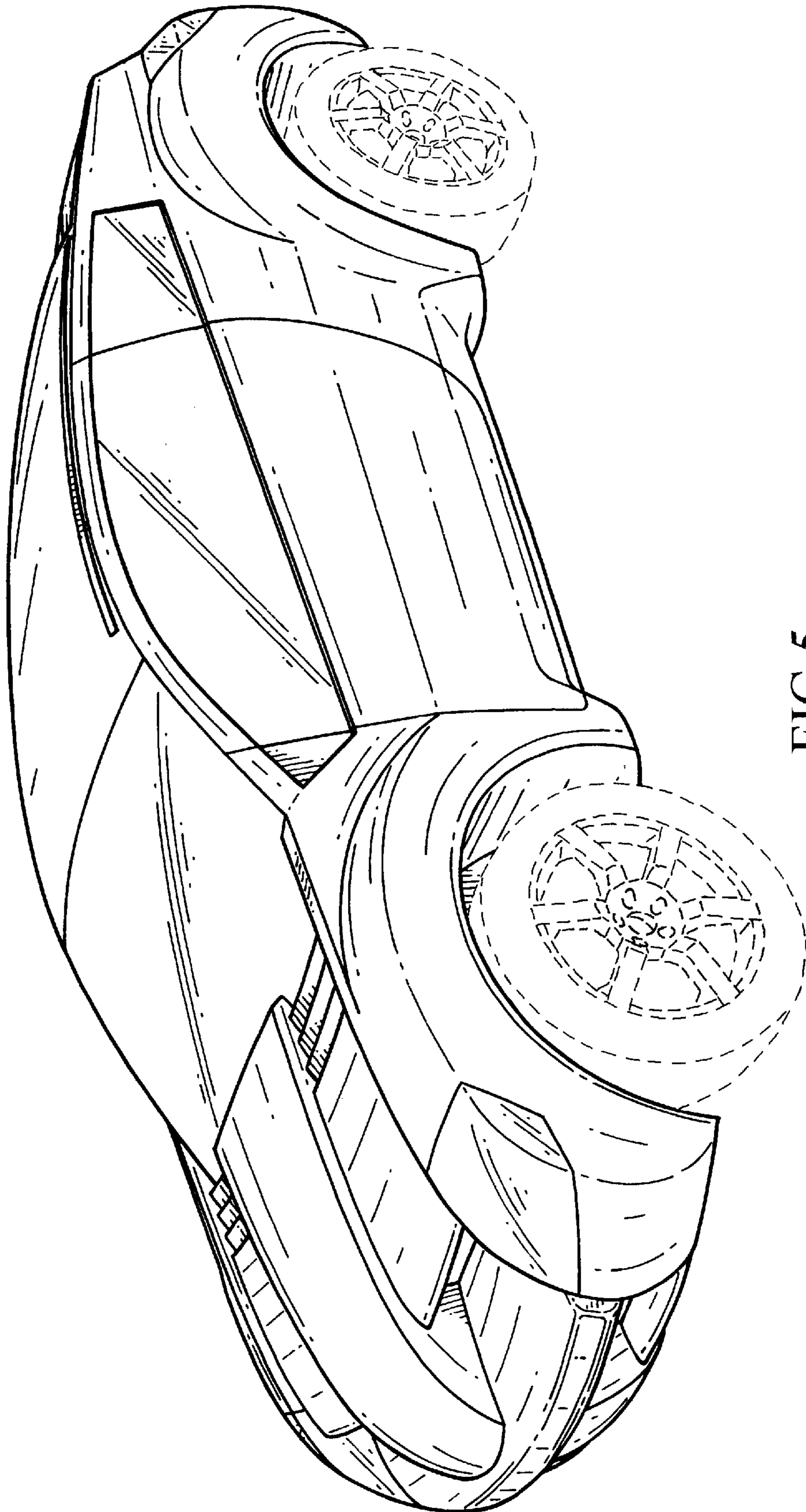

FIG.5

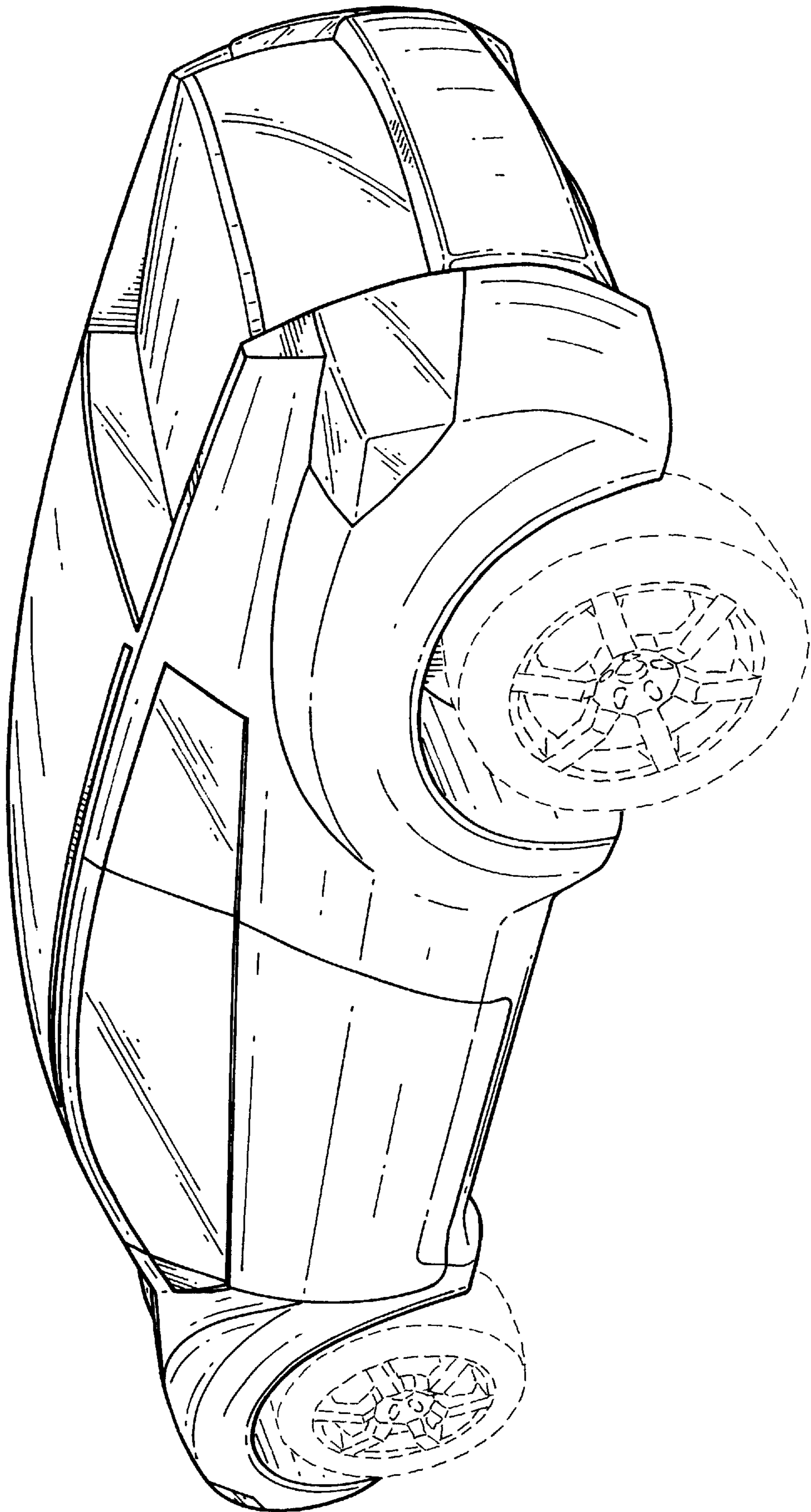

FIG.6