



US00D467204S

(12) **United States Design Patent**
Andresen

(10) **Patent No.:** **US D467,204 S**

(45) **Date of Patent:** **** Dec. 17, 2002**

(54) **CARDBOARD STRETCHER**

(75) Inventor: **Hans Kasper Andresen**, Lena (NO)

(73) Assignee: **Møller Vital AS**, Gjøvik (NO)

(**) Term: **14 Years**

(21) Appl. No.: **29/134,450**

(22) Filed: **Dec. 22, 2000**

(30) **Foreign Application Priority Data**

Jun. 23, 2000 (NO) 2000 0428

(51) **LOC (7) Cl.** **12-12**

(52) **U.S. Cl.** **D12/128**

(58) **Field of Search** D12/128, 132,
D12/133; D24/190; 5/625, 626, 627, 628

(56) **References Cited**

U.S. PATENT DOCUMENTS

2,394,264 A * 2/1946 Robinson 5/626

4,670,921 A * 6/1987 Avni et al. 5/627
D309,589 S * 7/1990 Hare et al. D12/128
5,048,134 A * 9/1991 Demill et al. 5/625
D332,930 S * 2/1993 Clark et al. D12/128
D346,346 S * 4/1994 Johnson et al. D12/128

* cited by examiner

Primary Examiner—Marcus A. Jackson

(74) *Attorney, Agent, or Firm*—Finnegan, Henderson, Farabow, Garrett & Dunner, L.L.P.

(57) **CLAIM**

The ornamental design for cardboard stretcher, as shown and described.

DESCRIPTION

FIG. 1 is a perspective view of a cardboard stretcher showing my new design;

FIG. 2 is an end view of the cardboard stretcher of FIG. 1; and,

FIG. 3 is a top plan view of the cardboard stretcher.

1 Claim, 2 Drawing Sheets

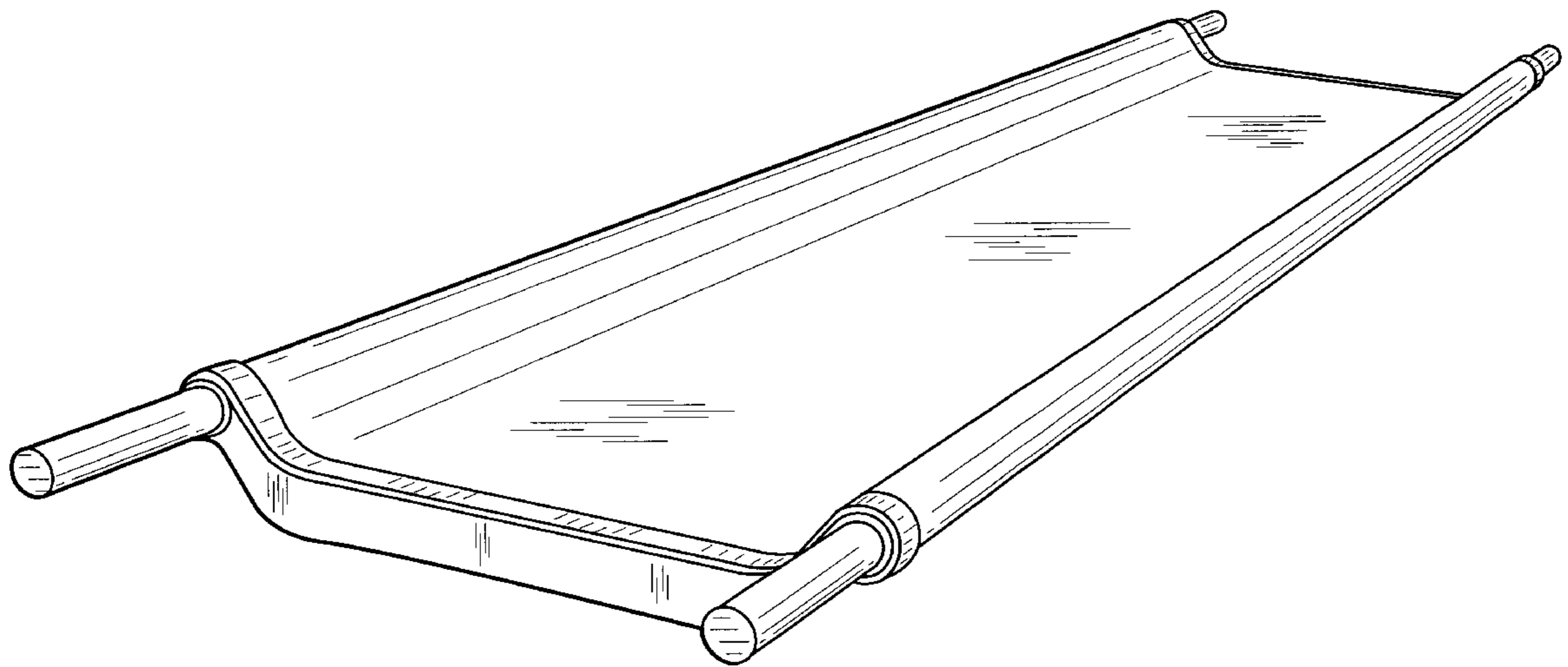

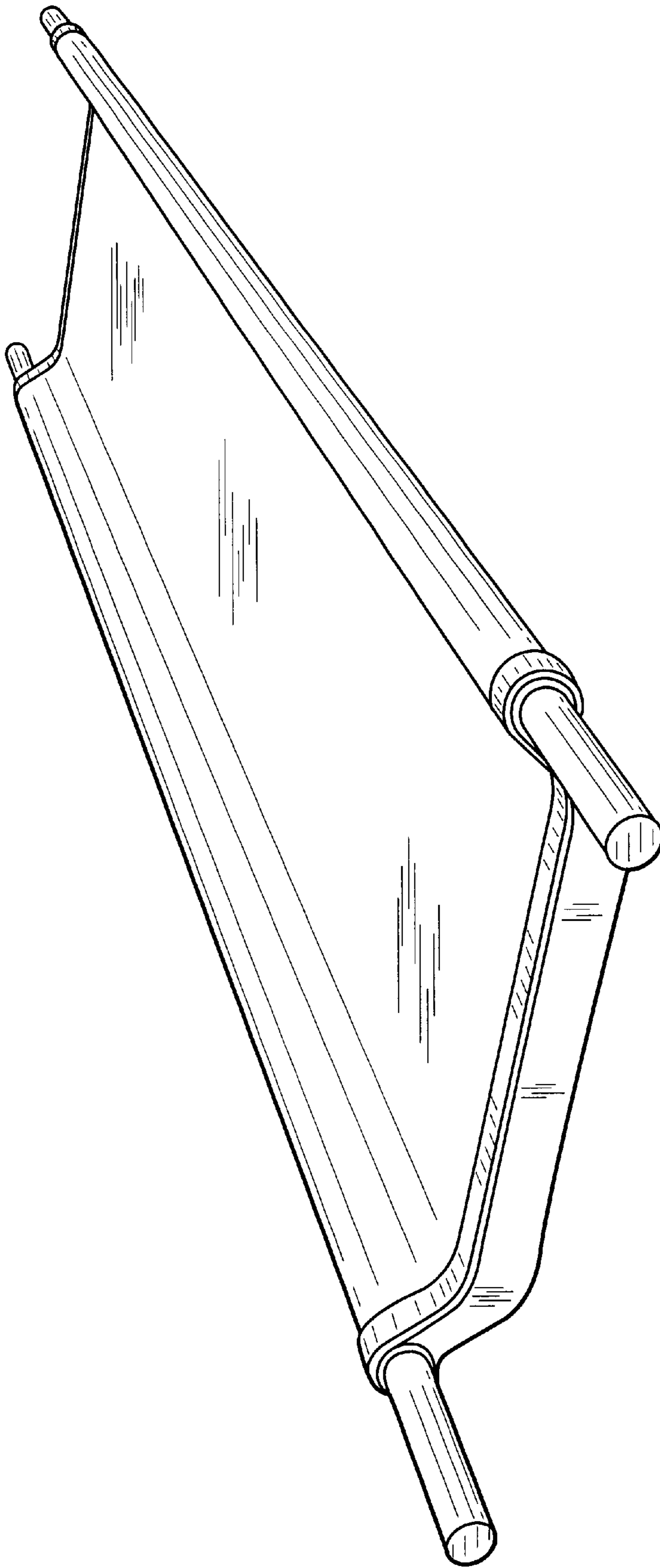

FIG. 1



FIG. 2

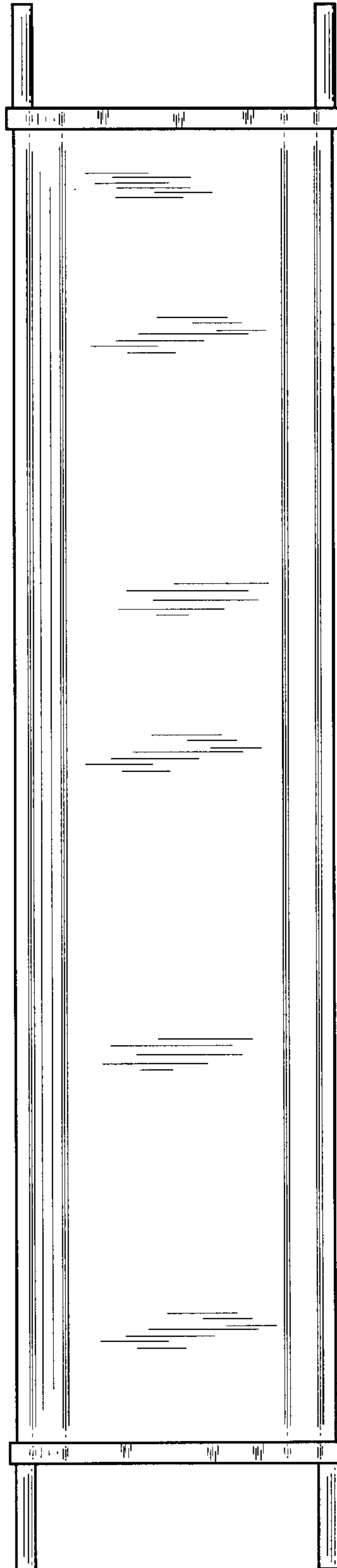

FIG. 3