



US00D467019S

(12) **United States Design Patent** (10) **Patent No.:** **US D467,019 S**
Horowitz (45) **Date of Patent:** **** Dec. 10, 2002**

(54) **TAIL LENS ASSEMBLY**

(76) Inventor: **Brian A. Horowitz**, 252 Granite St.,
Corona, CA (US) 92879

(**) Term: **14 Years**

(21) Appl. No.: **29/155,332**

(22) Filed: **Feb. 8, 2002**

Three photographs of rear view of Honda Civic automobile,
prior to Jul. 25, 2001.

(List continued on next page.)

Primary Examiner—Marcus A. Jackson
(74) *Attorney, Agent, or Firm*—Knobbe, Martens, Olson &
Bear, LLP

(57) **CLAIM**

The ornamental design for a tail lens assembly, as shown and
described.

Related U.S. Application Data

(63) Continuation-in-part of application No. 29/145,570, filed on
Jul. 25, 2001.

(51) **LOC (7) Cl.** **26-04**

(52) **U.S. Cl.** **D26/28**

(58) **Field of Search** D26/28–36; 362/80,
362/81, 82, 83, 83.4, 267, 269, 275

(56) **References Cited**

U.S. PATENT DOCUMENTS

D382,659 S	8/1997	Kaloustian
D388,200 S	12/1997	Tomforde et al.
D388,897 S	1/1998	Tomforde et al.
D389,256 S	1/1998	Sacco et al.
D396,310 S	7/1998	Sacco et al.
D399,983 S	10/1998	Cadotte et al.
D406,910 S	3/1999	Bangle
D409,772 S	5/1999	Bangle
D412,214 S	7/1999	Hejtmanek

(List continued on next page.)

OTHER PUBLICATIONS

Advertisement—Stillen Sports Cars from Sport Compact Car,
vol. 13, No. 03, Mar. 2001. pp. 58–59 Prior to Jul. 25, 2001.
Three photographs of rear view of Chevy S–10 truck, prior
to Jul. 25, 2001.

Three photographs of rear view of Acura Integra automobile,
prior to Jul. 25, 2001.

Three photographs of rear view of Dodge Neon automobile,
prior to Jul. 25, 2001.

Three photographs of rear view of Honda Accord automo-
bile, prior to Jul. 25, 2001.

DESCRIPTION

FIG. 1 is a front-right perspective view of a preferred
embodiment of the tail lens assembly according to the
present design, with the broken line showing for illustrative
purposes only and forming no part of the claimed design;
FIG. 2 is a partially exploded front-right perspective view of
the tail lens assembly of FIG. 1, illustrating the cover of the
tail lens assembly removed;

FIG. 3 is a front elevational view of the tail lens assembly
of FIG. 1;

FIG. 4 is a right-side elevational view of the tail lens
assembly of FIG. 1;

FIG. 5 is a top plan view of the tail lens assembly of FIG.
1;

FIG. 6 is a front-right perspective view of the tail lens
assembly of FIG. 1, showing the tail lens assembly installed
on a vehicle;

FIG. 7 is a front-right perspective view of another preferred
embodiment of the tail lens assembly according to the
present design;

FIG. 8 is a partially exploded front-right perspective view of
the tail lens assembly of FIG. 7, illustrating the cover of the
tail lens assembly removed;

FIG. 9 is a front elevational view of the tail lens assembly
of FIG. 7;

FIG. 10 is a right-side elevational view of the tail lens
assembly of FIG. 7;

FIG. 11 is a top plan view of the tail lens assembly of FIG.
7;and,

FIG. 12 is a front-right perspective view of the tail lens
assembly of FIG. 7, showing the tail assembly installed on
a vehicle.

1 Claim, 8 Drawing Sheets

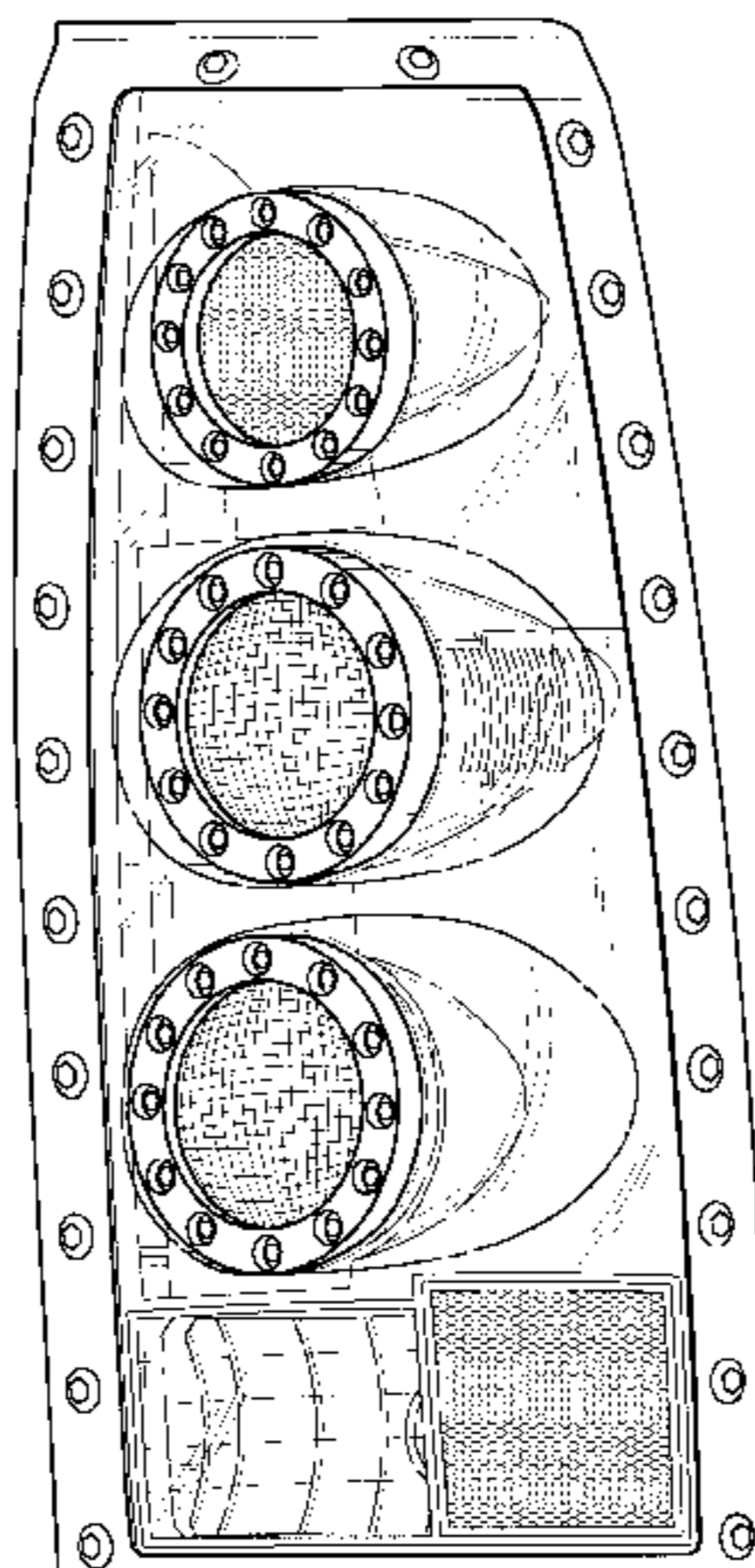

U.S. PATENT DOCUMENTS

D412,587 S 8/1999 Bangle
D413,400 S 8/1999 Bangle
D414,571 S * 9/1999 Schneider et al. D26/28
D416,638 S 11/1999 Horbury et al.
D427,363 S 6/2000 Sacco et al.
D429,353 S 8/2000 Pfeiffer
D439,995 S 4/2001 Nakazawa et al.
D440,331 S 4/2001 Nakazawa et al.
6,243,008 B1 6/2001 Korabiak
D448,869 S 10/2001 Horowitz
D449,898 S 10/2001 Horowitz
6,296,382 B1 10/2001 Hamelbeck

OTHER PUBLICATIONS

Three photographs of rear view of Chevrolet C/K truck,
prior to Jul. 25, 2001.
American Products Company 2001 Catalog, pp. 10–13,
published Oct. 10, 2000.

Promotional material from Sigma Polyurethane Interna-
tional, prior to Jul. 25, 2001.

Toucan Industries, Inc. 2001 Catalog, p. 25, prior to Oct. 30,
2000.

Hiper Industries 2002 Catalog, p. 4 (prior to Jan. 1, 2002).
in.pro.carwear Catalog, p. 16 (prior to Jan. 1, 2002).

Legaparts Brochure, p. 4 (prior to Jan. 1, 2002).

Macro Automotive Products Brochure (prior to Jan. 1,
2002).

Matrix GR Motorsports 2002 Catalog, p. 15 & 17 (prior to
Jan. 1, 2002).

Toucan Industries 2001–2002 Catalog, p. 27 (prior to Jan. 1,
2002).

Z2000 Brochure, p. 4 (prior to Jan. 1, 2002).

CaliforniaStylin.com ad from Mini Trucking, Nov. 2001.

* cited by examiner

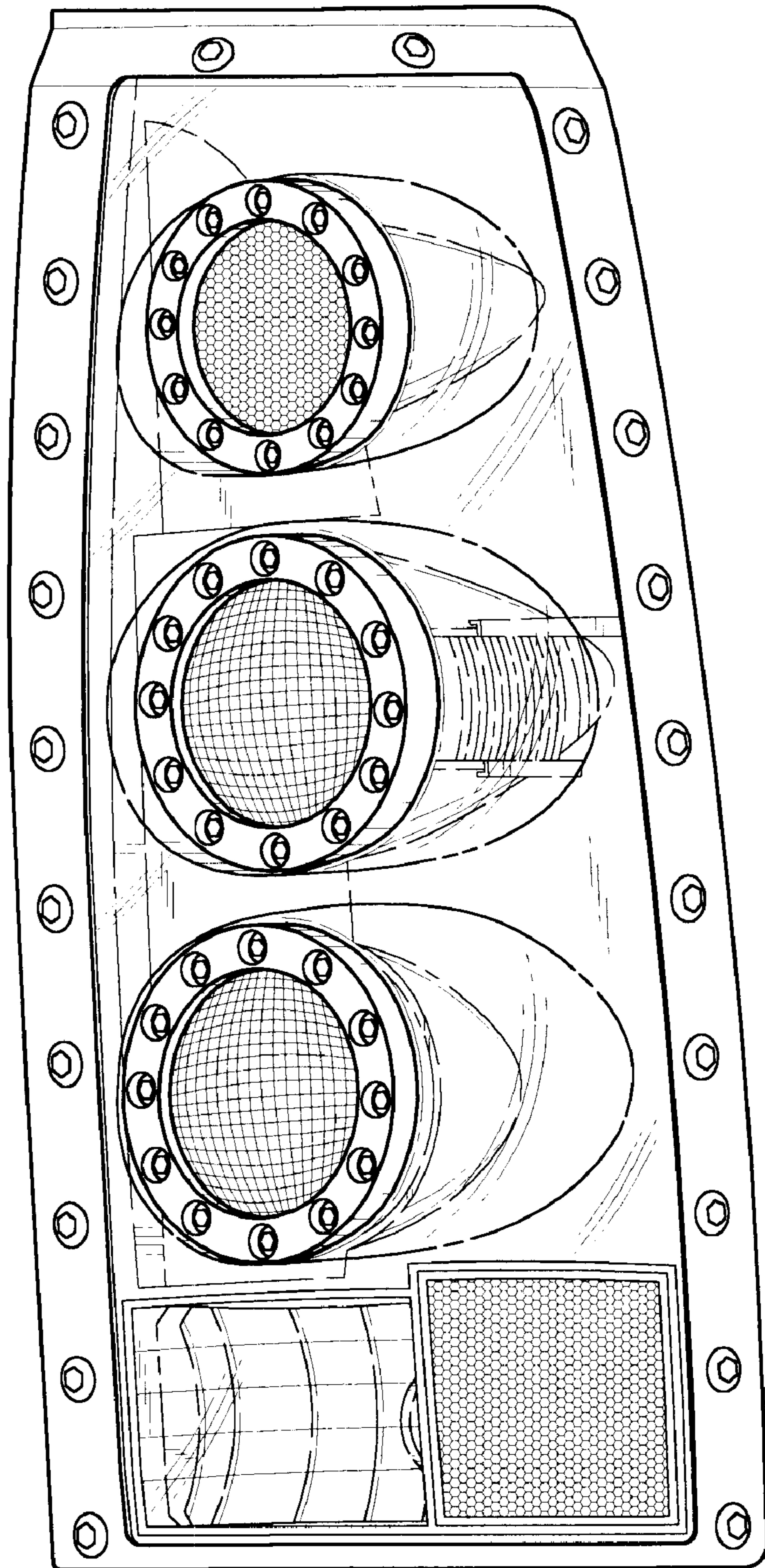

FIG. 1

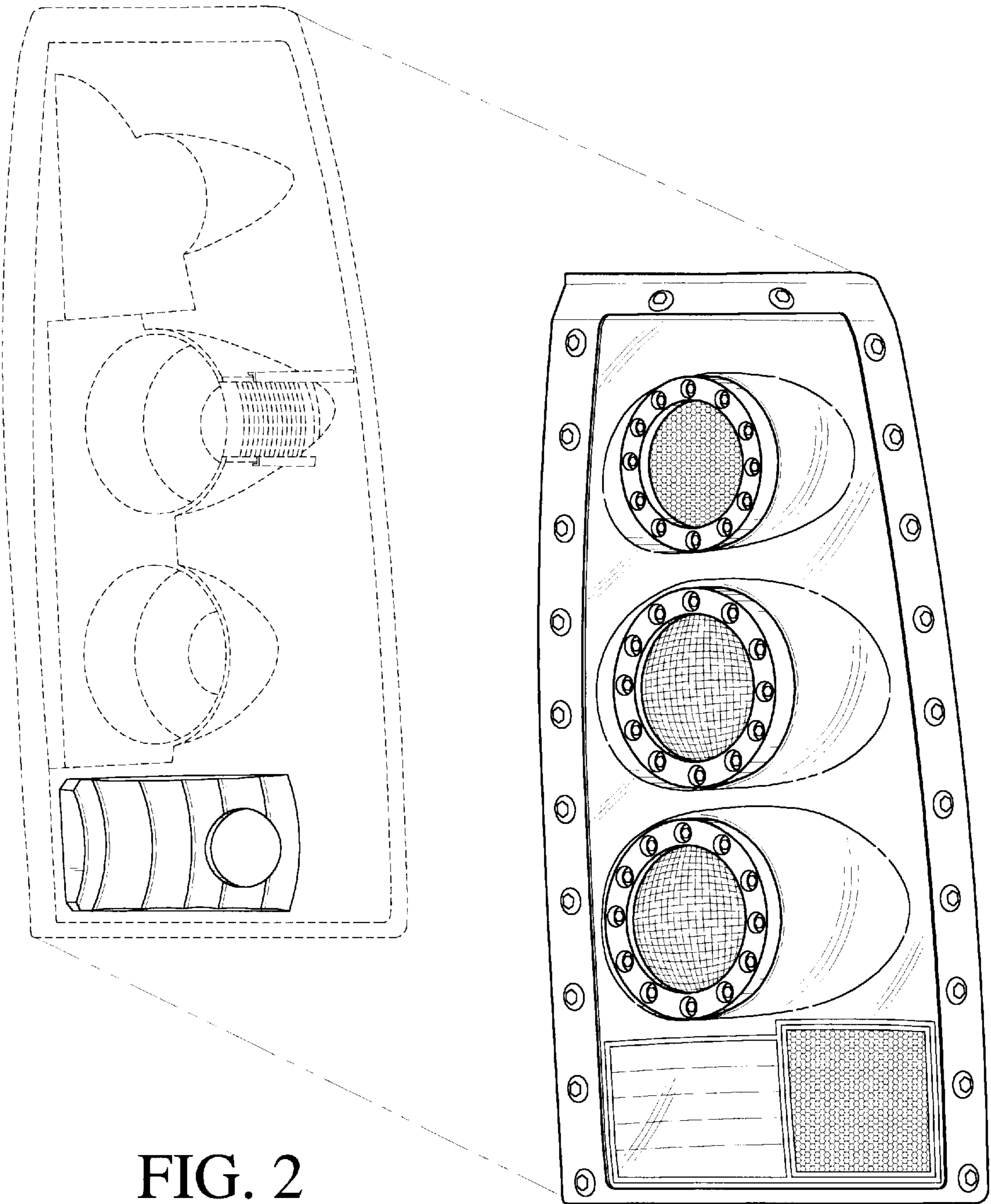

FIG. 2

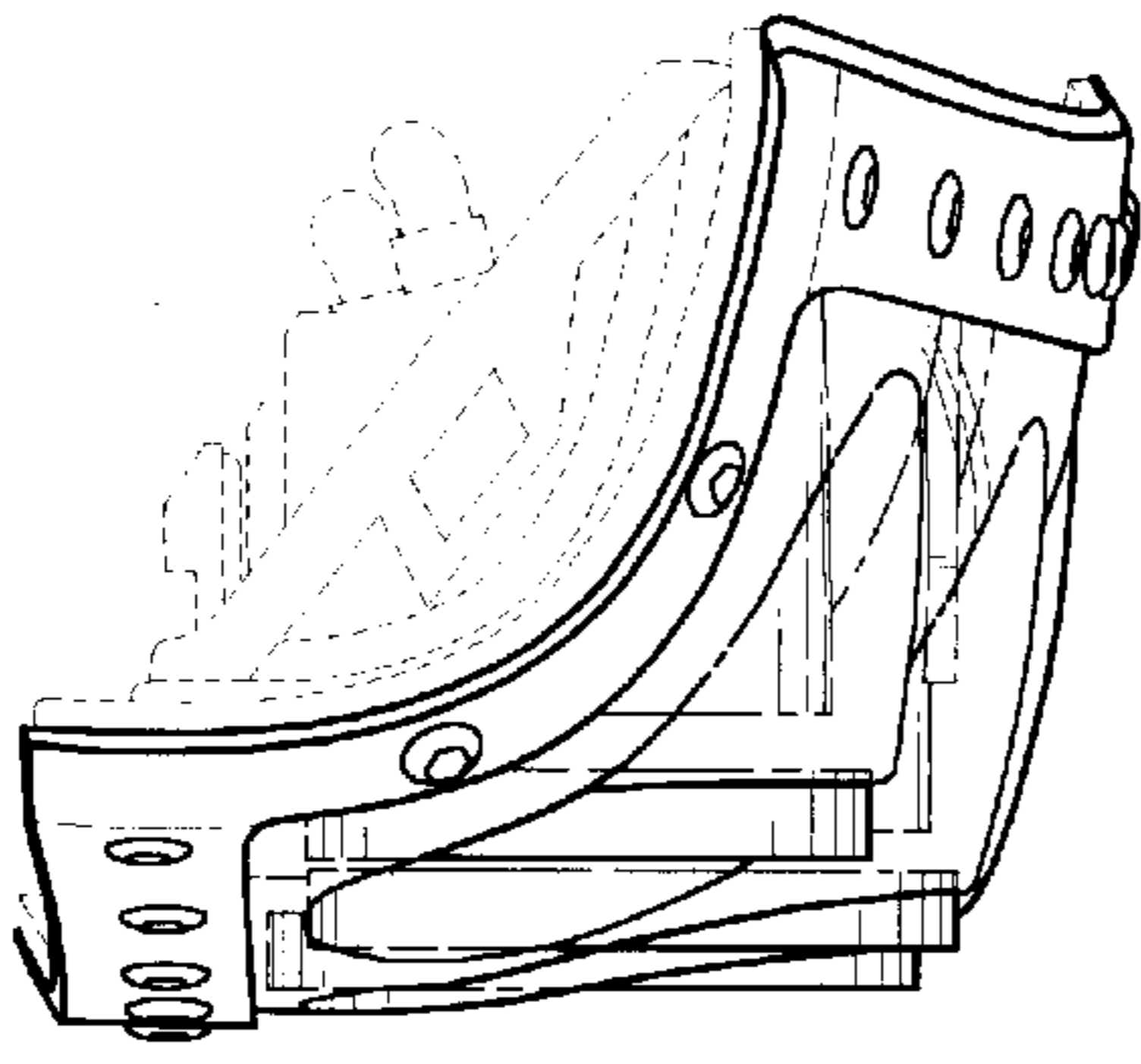

FIG. 5

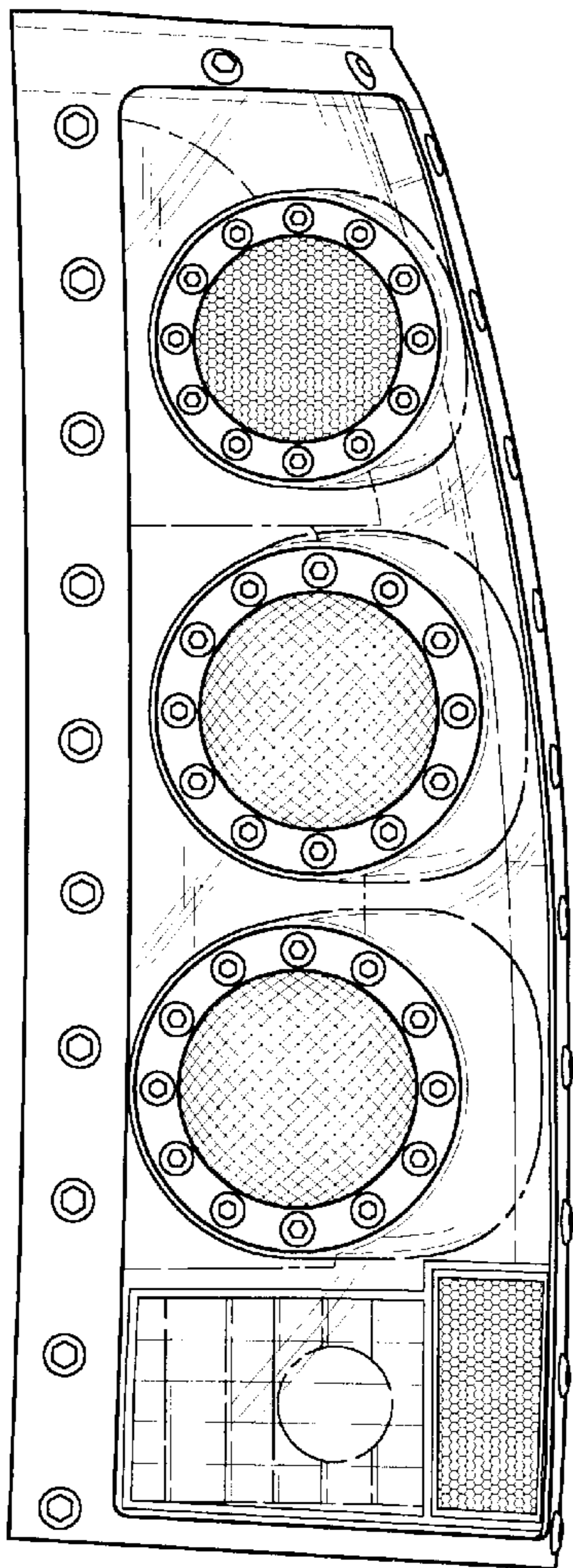

FIG. 3

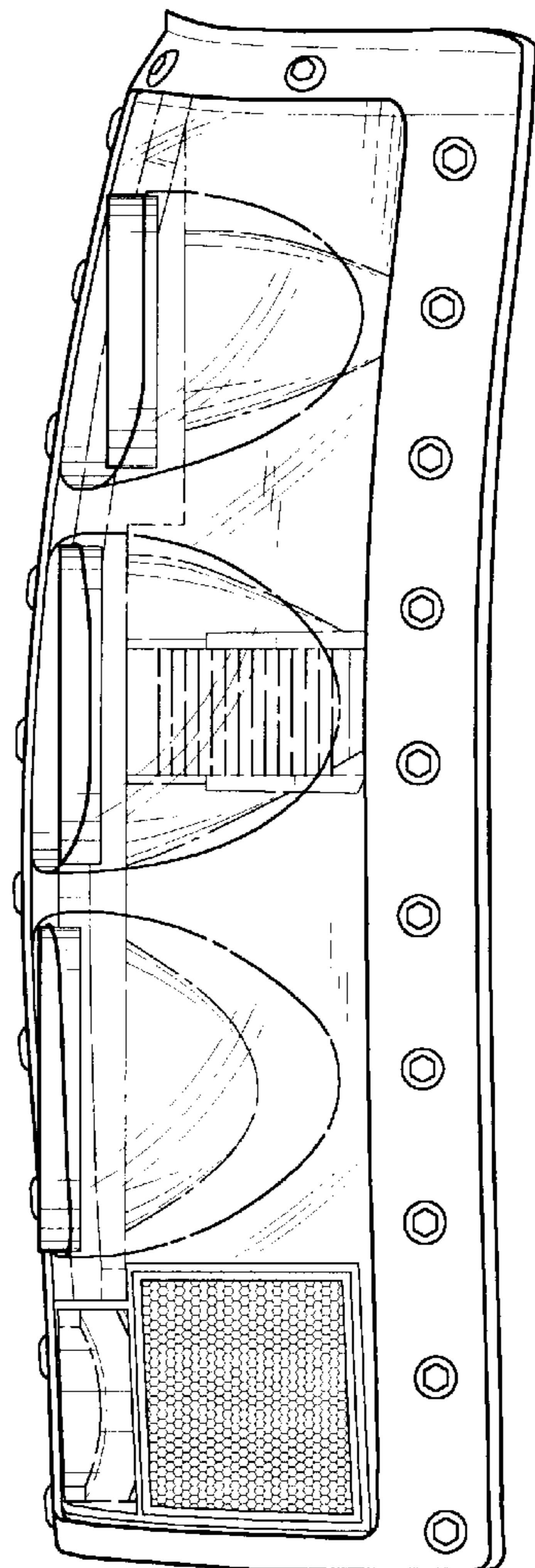

FIG. 4

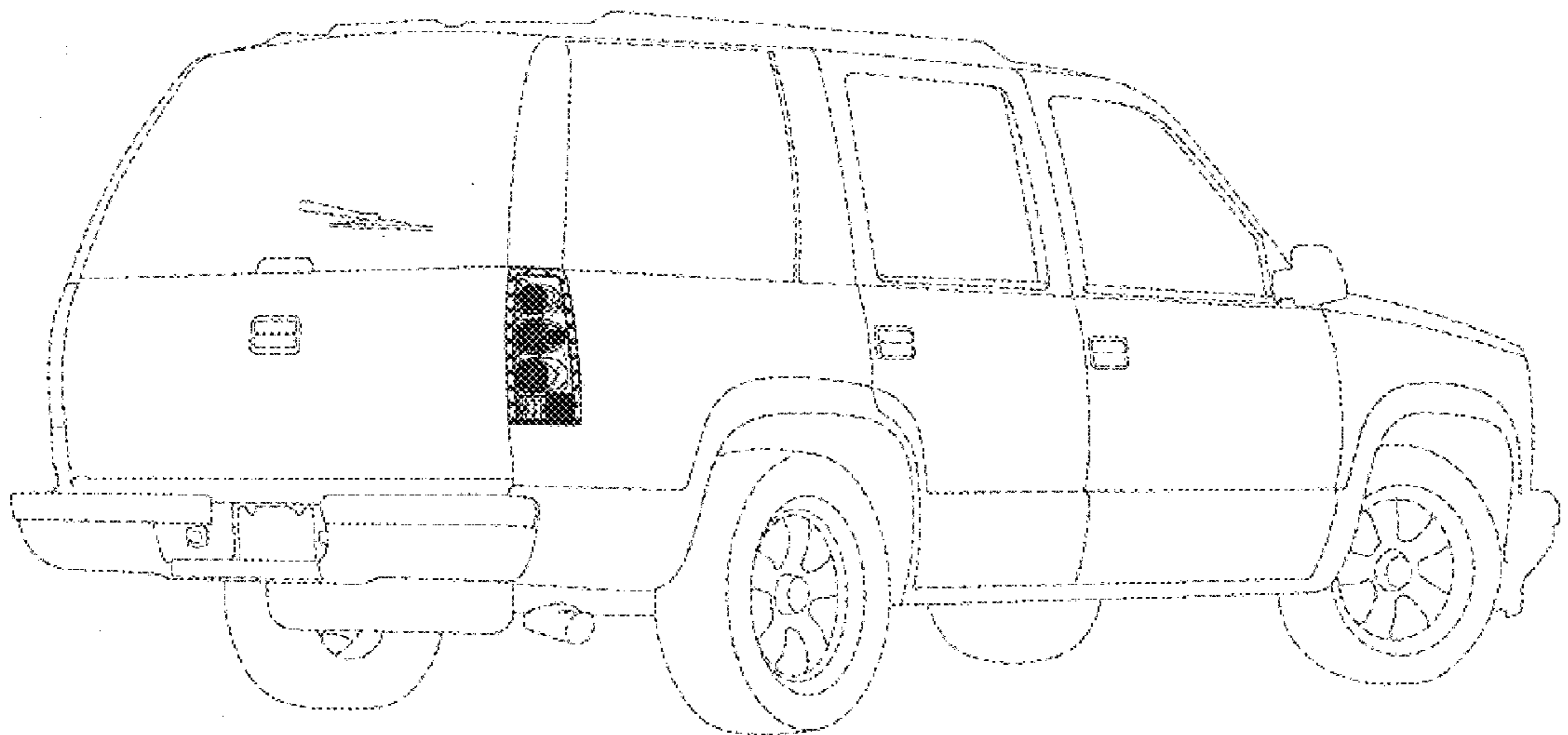

FIG. 6

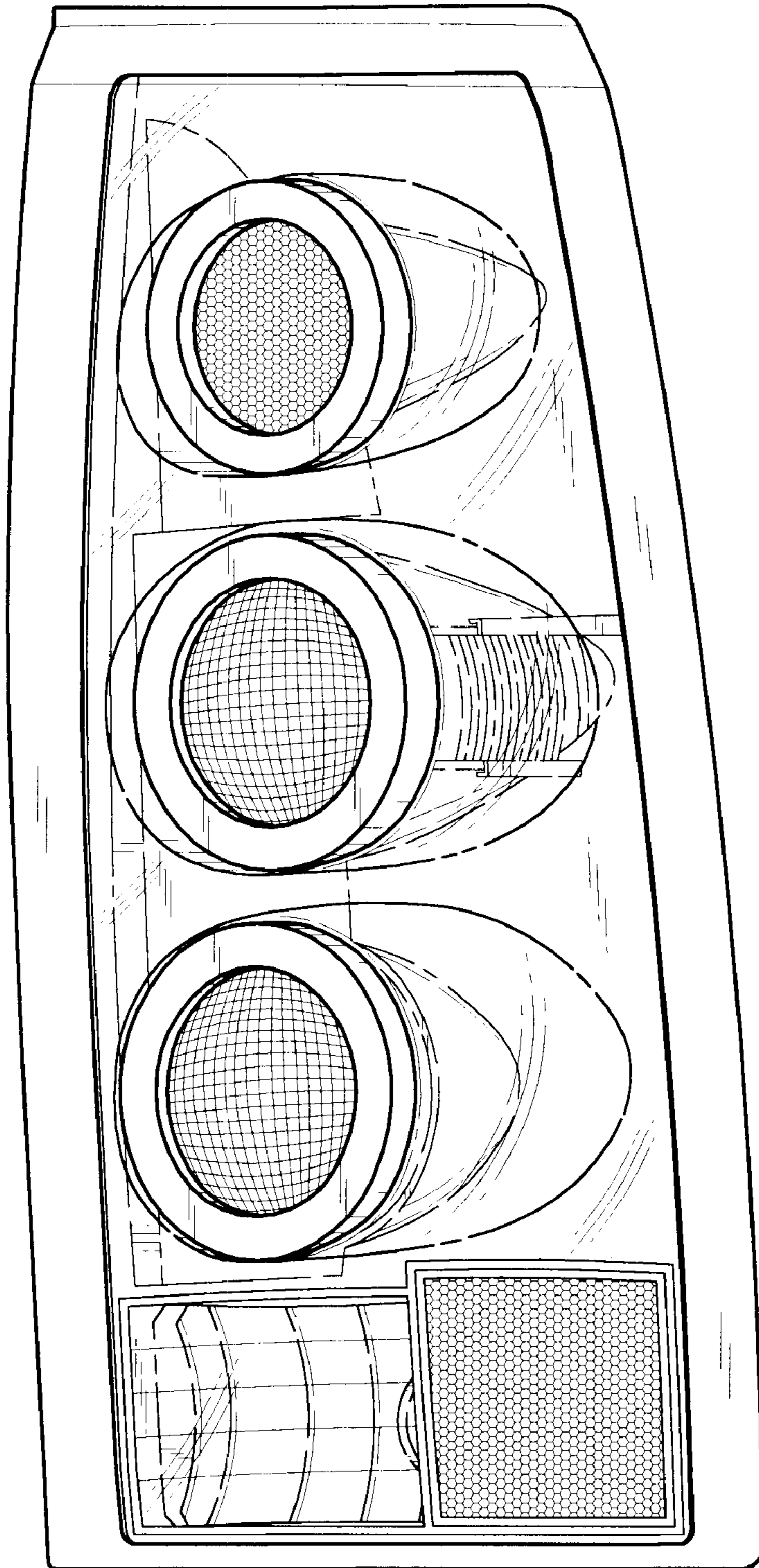

FIG. 7

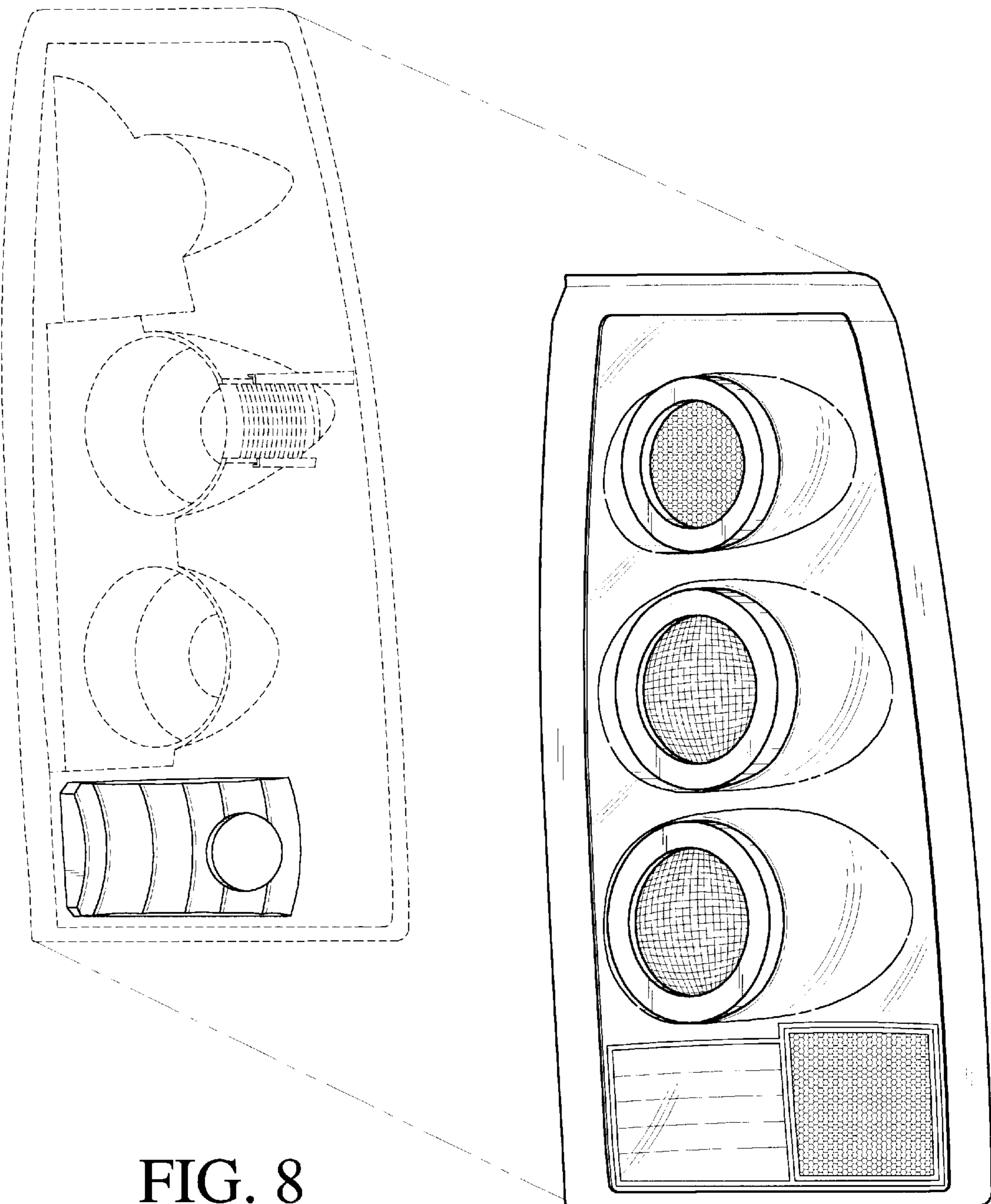

FIG. 8

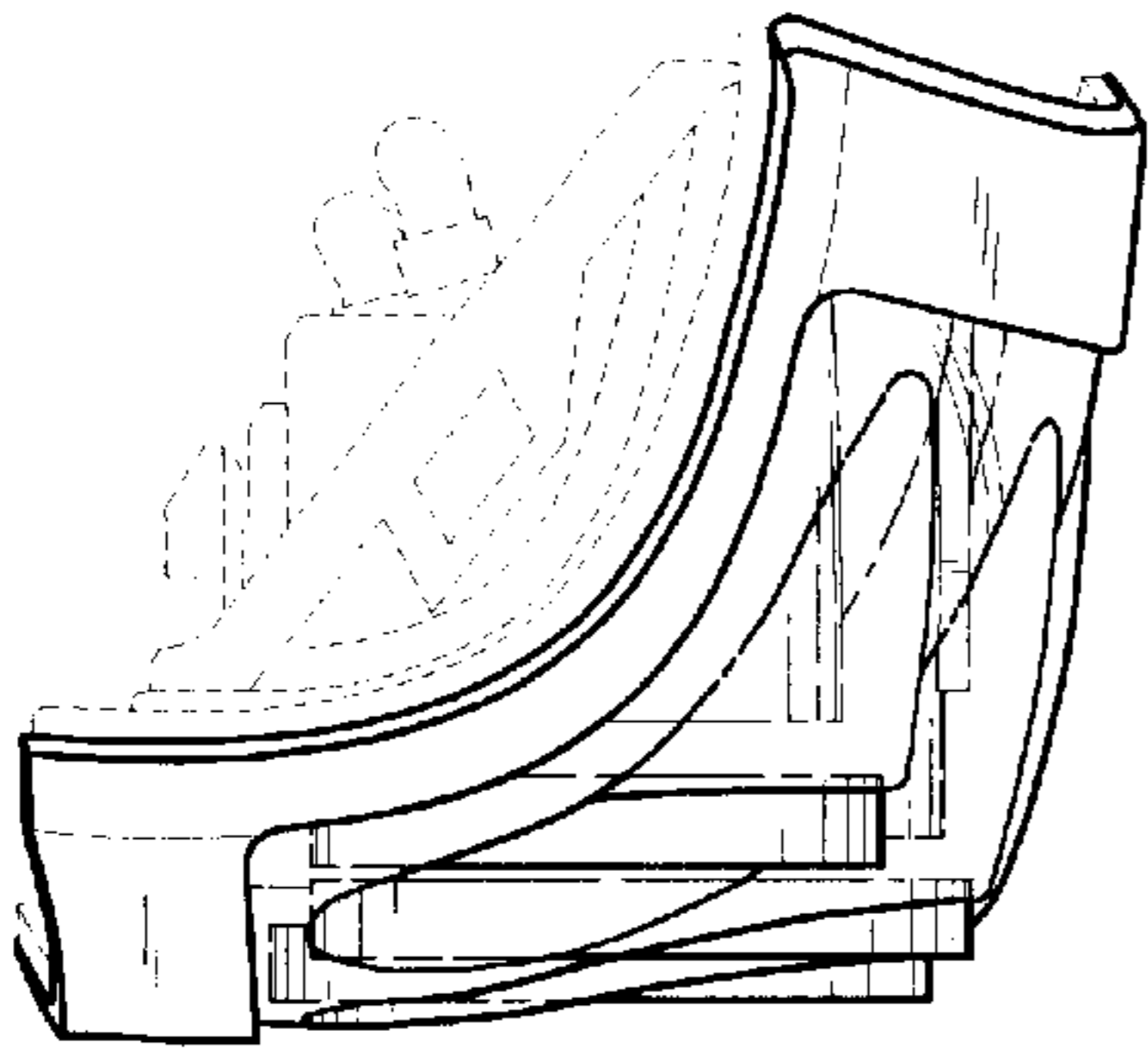

FIG. 11

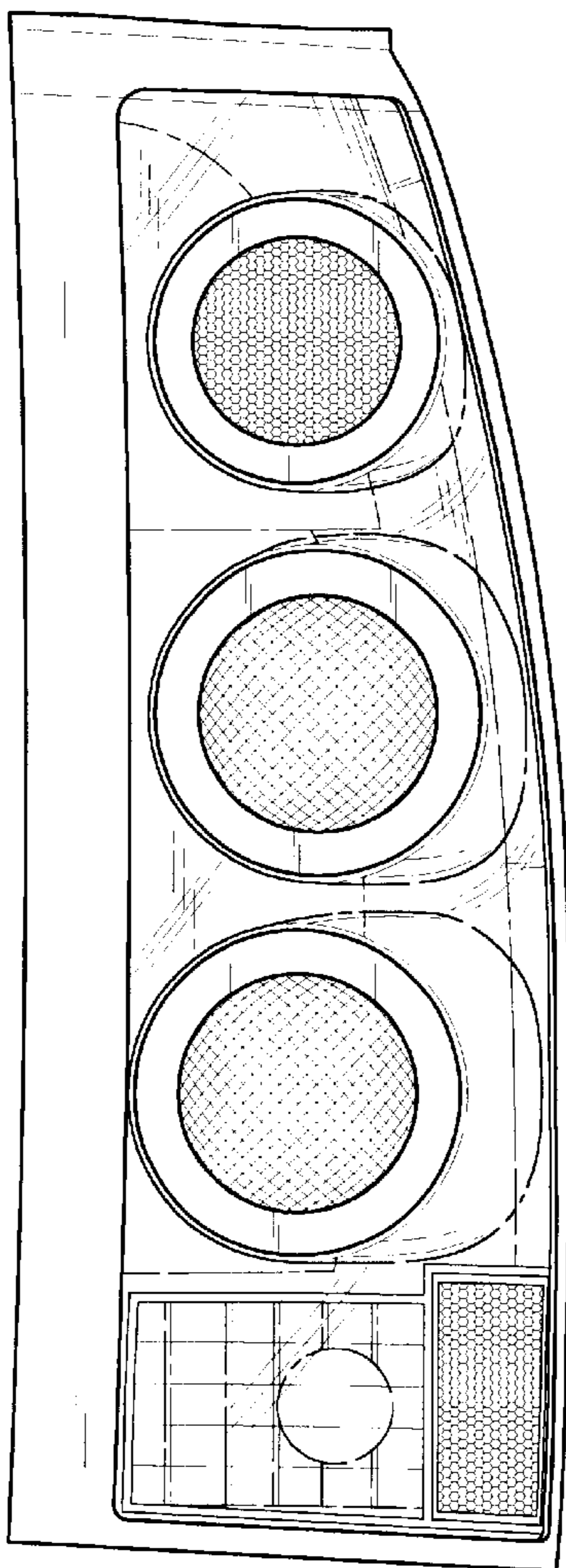

FIG. 9

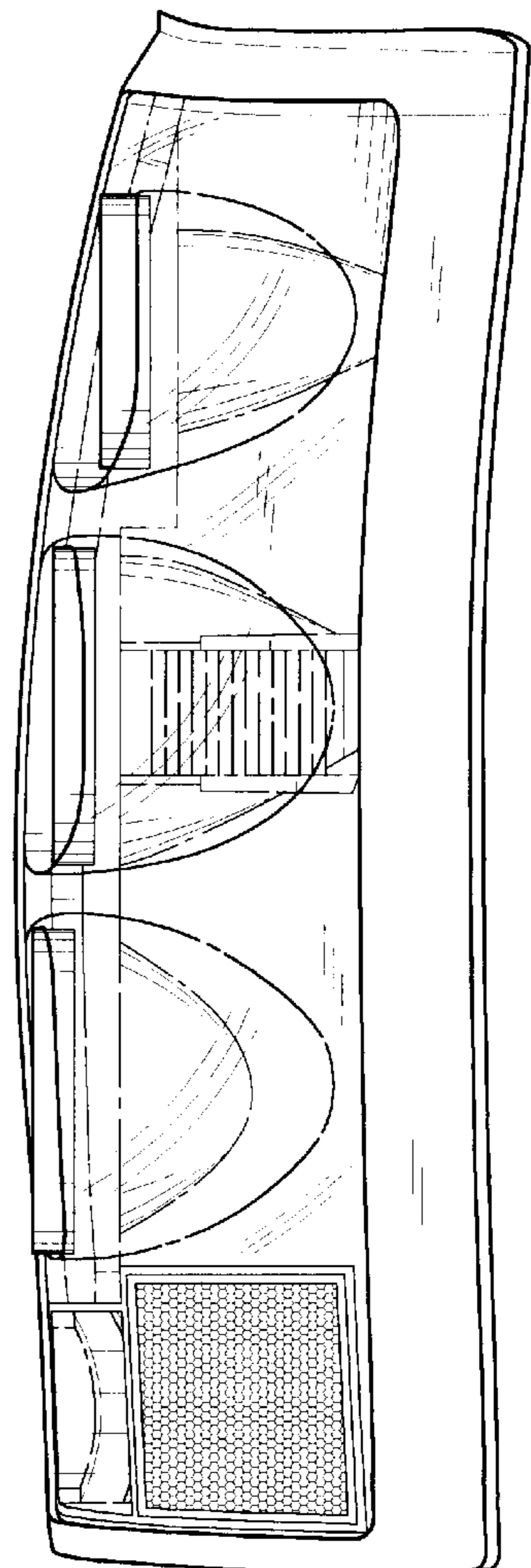

FIG. 10

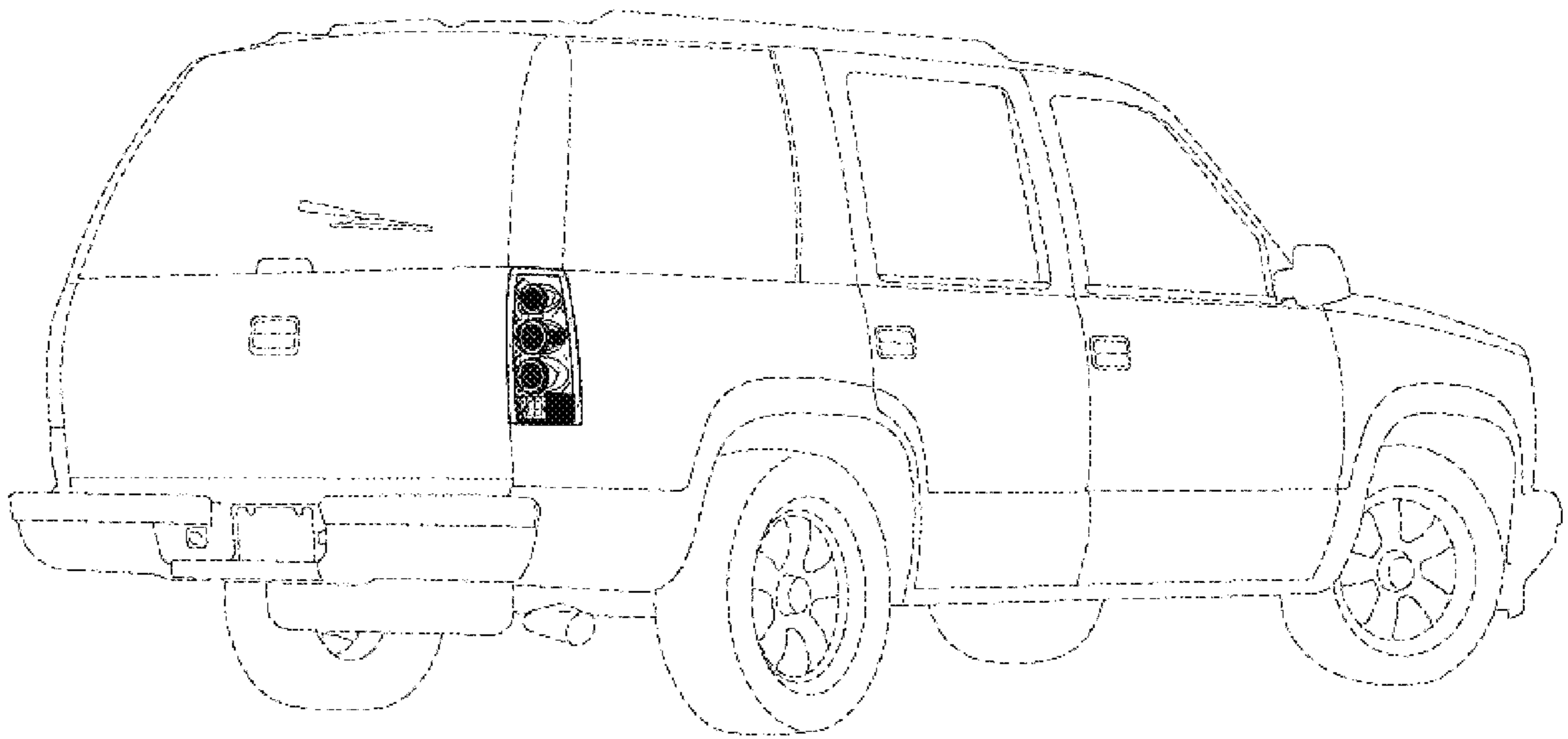

FIG. 12