



US00D466845S

(12) **United States Design Patent**
Kutzscher

(10) **Patent No.:** **US D466,845 S**

(45) **Date of Patent:** **** Dec. 10, 2002**

(54) **REINFORCEMENT RING FOR A TRAILER HITCH RECEIVER**

(75) Inventor: **Michael Kutzscher**, Huntsville (CA)

(73) Assignee: **Hidden Hitch of Canada**, Ontario (CA)

(**) Term: **14 Years**

(21) Appl. No.: **29/148,287**

(22) Filed: **Sep. 18, 2001**

(51) **LOC (7) Cl.** **12-16**

(52) **U.S. Cl.** **D12/162**

(58) **Field of Search** D12/162, 400; D9/441, 451; D23/260; 138/89-89.4; 211/14; 280/495, 506-507, 491.1-491.2; 293/122

(56) **References Cited**

U.S. PATENT DOCUMENTS

5,072,962 A	12/1991	Webb	
5,149,122 A	9/1992	Helber	
5,184,840 A	2/1993	Edwards	
5,203,194 A	4/1993	Marquardt	
5,277,448 A	1/1994	Colibert	
D355,630 S	* 2/1995	Liland et al. D12/162
5,431,425 A	7/1995	Klinkman	
D372,892 S	8/1996	McCoy et al.	
5,620,198 A	4/1997	Borchers	
5,685,554 A	11/1997	Poxleitner	
5,695,204 A	12/1997	Ford	
D409,960 S	5/1999	Young	
D424,991 S	* 5/2000	Young et al. D12/162
D425,833 S	* 5/2000	Robinson D12/162

OTHER PUBLICATIONS

Draw-Tite 1990 Hitch Applications and Accessories, 1989 Front and Rear Covers.

* cited by examiner

Primary Examiner—Stacia Cadmus

(74) *Attorney, Agent, or Firm*—Harness, Dickey & Pierce, PLC

(57) **CLAIM**

The ornamental design for a reinforcement ring for a trailer hitch receiver, as shown and described.

DESCRIPTION

FIG. 1 is a perspective view of a reinforcement ring for a trailer hitch receiver showing my new design; FIG. 2 is a front elevational view of the reinforcement ring for a trailer hitch receiver shown in FIG. 1; FIG. 3 is a top plan view of the reinforcement ring for a trailer hitch receiver shown in FIG. 1; FIG. 4 is a left side view of the reinforcement ring for a trailer hitch receiver shown in FIG. 1; FIG. 5 is a right side view of the reinforcement ring for a trailer hitch receiver shown in FIG. 1; and, FIG. 6 is a bottom plan view of the reinforcement ring for a trailer hitch receiver shown in FIG. 1.

The broken lines are for environmental purposes only and form no part of the claimed design. It will be understood that the rear view is not seen during normal use and forms no part of the present invention.

1 Claim, 3 Drawing Sheets

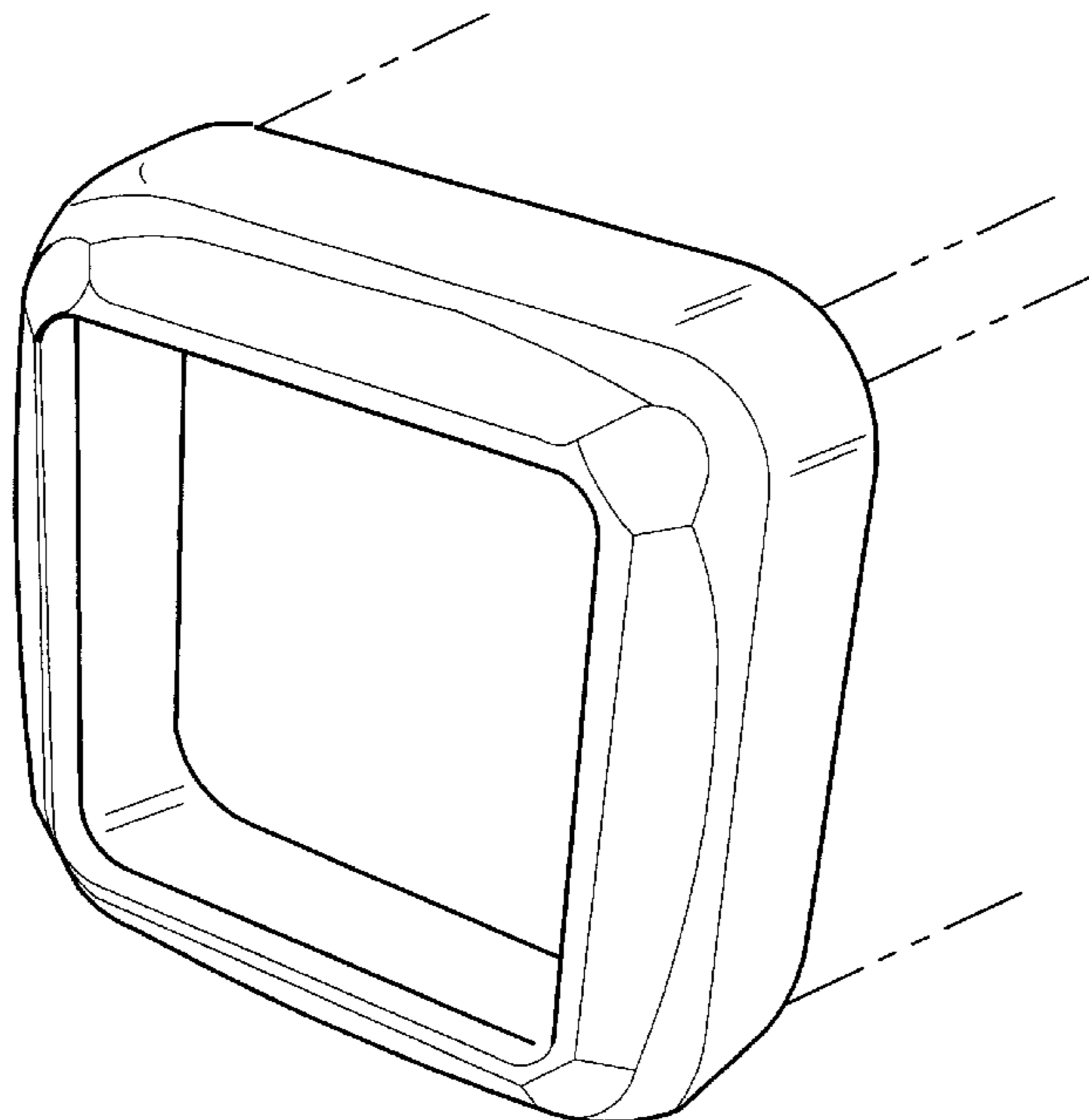

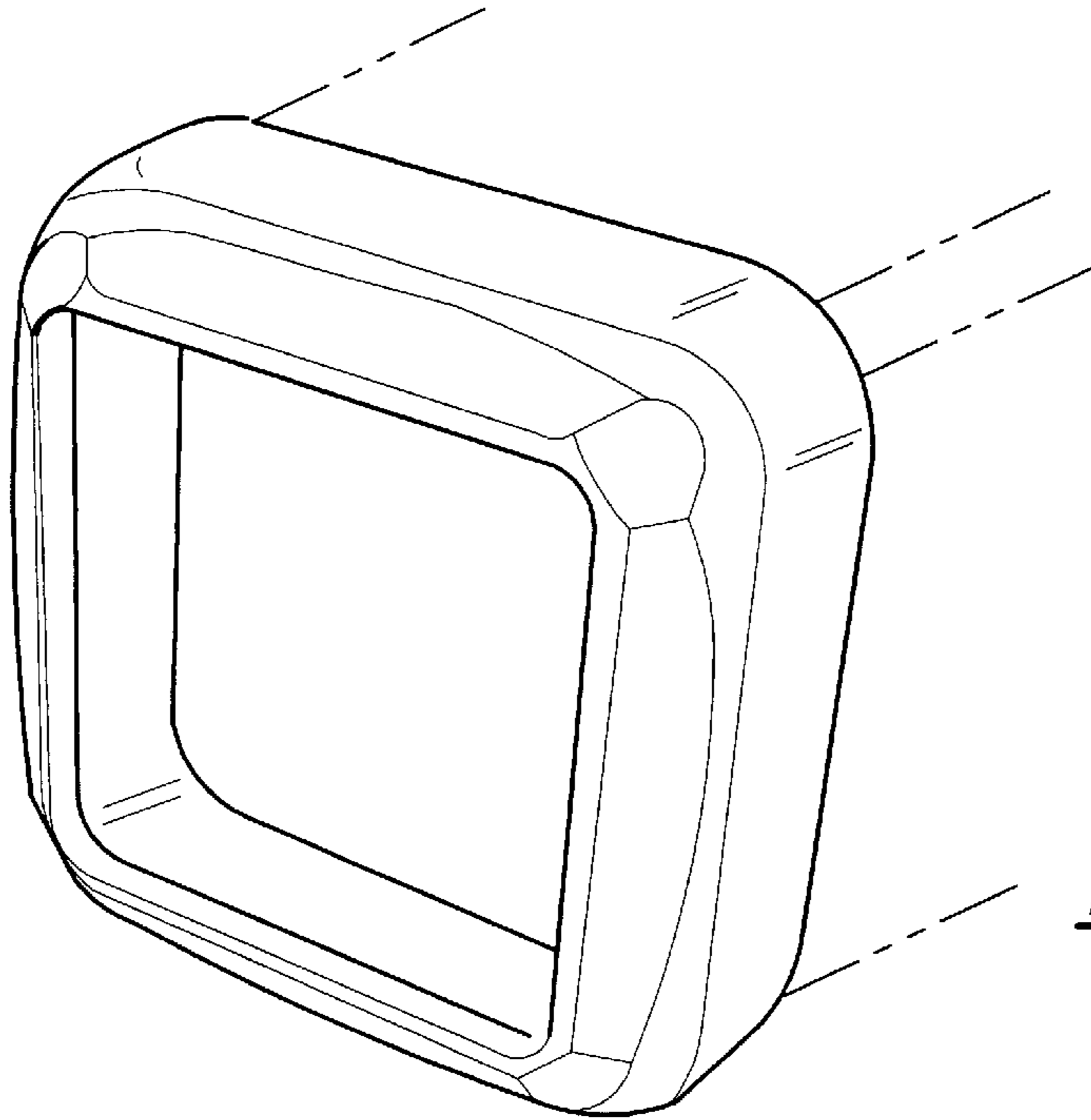

Figure - 1

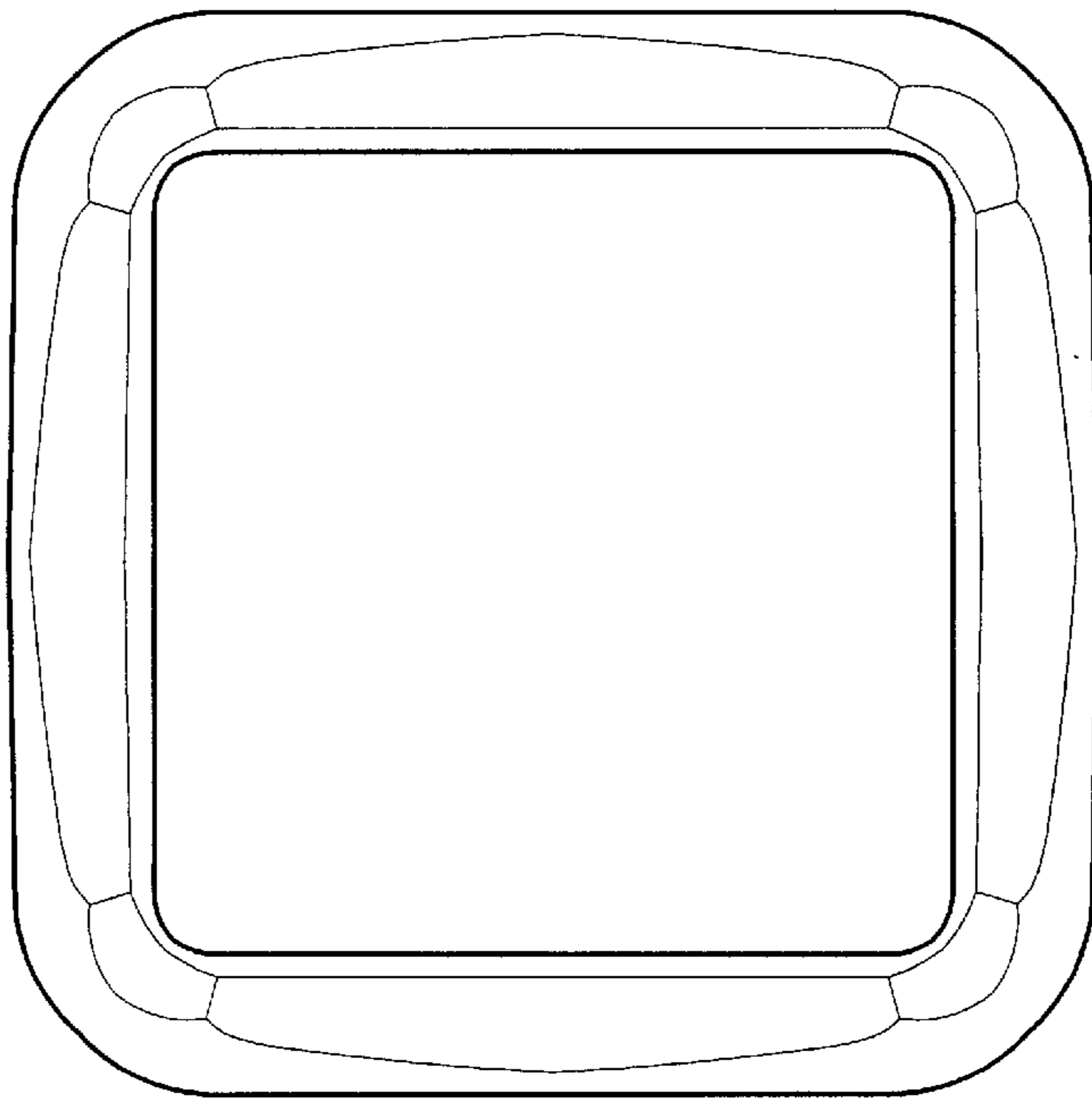

Figure - 2

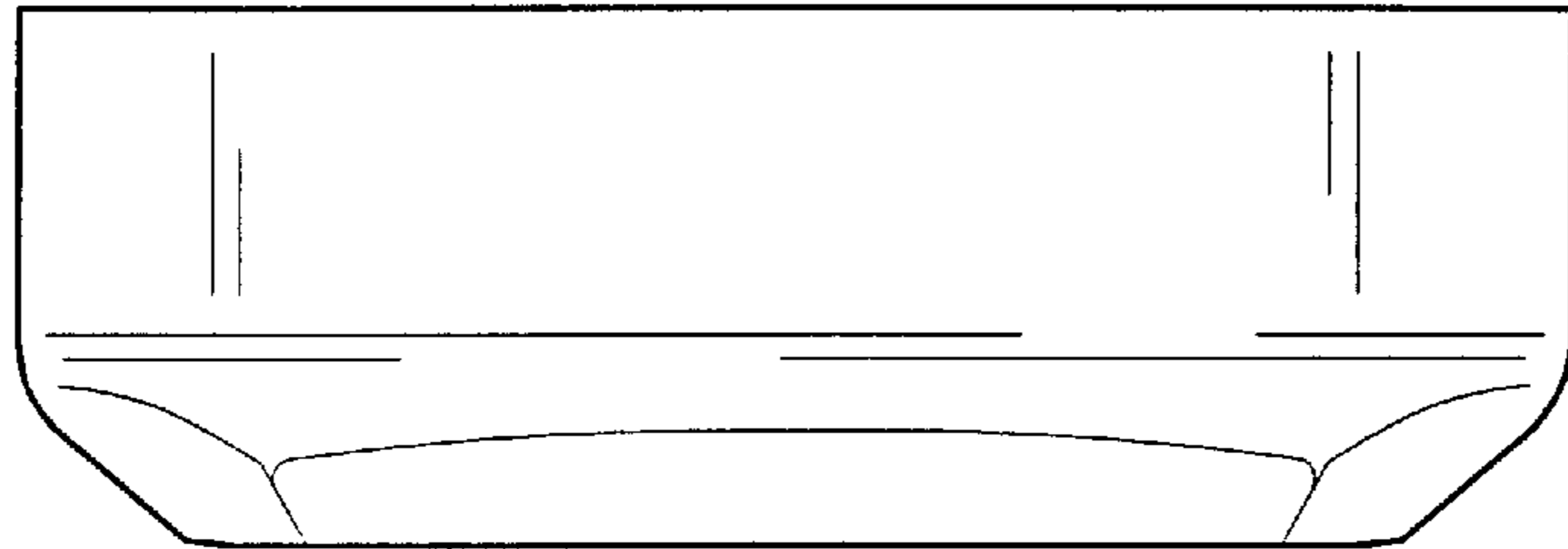

Figure - 3

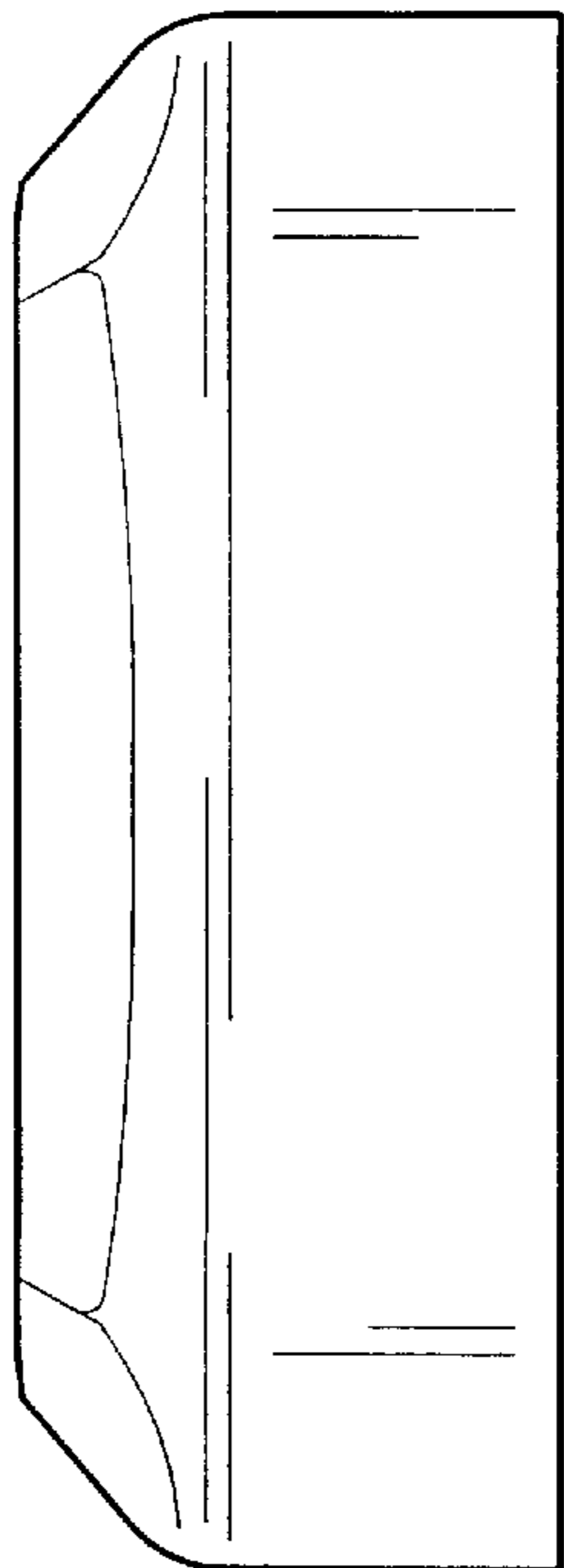

Figure - 5

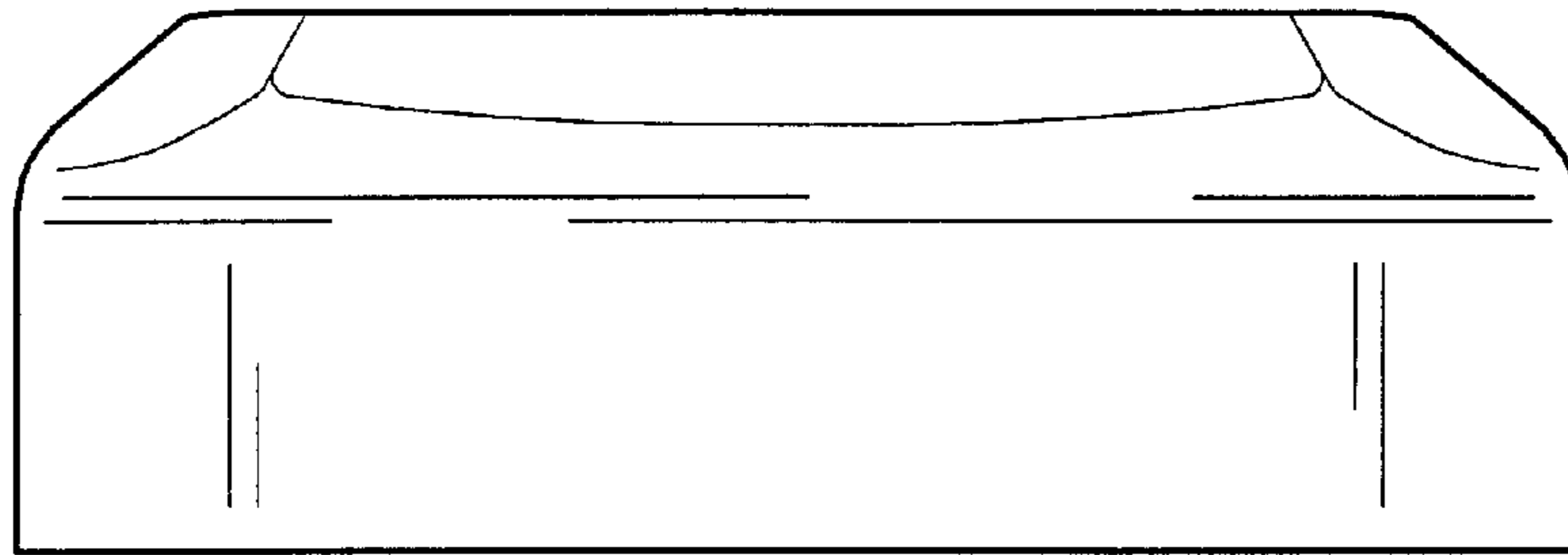

Figure - 6

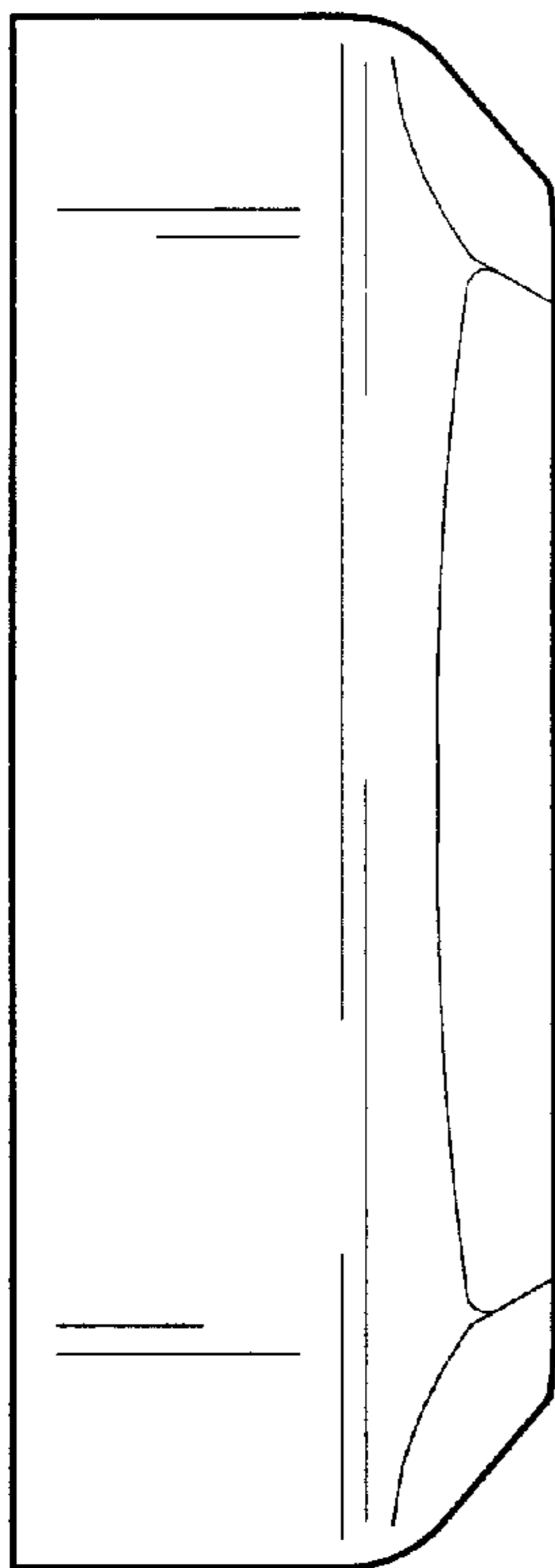

Figure - 4