



US00D466525S

(12) **United States Design Patent**
Makino et al.

(10) **Patent No.:** **US D466,525 S**

(45) **Date of Patent:** **** Dec. 3, 2002**

(54) **ELECTRIC DRIVEN COMPRESSOR**

(75) Inventors: **Masahiko Makino**, Shiga (JP);
Yoshifumi Abe, Shiga (JP); **Tsutomu Sakurabayashi**, Osaka (JP)

(73) Assignee: **Matsushita Electric Industrial Co., Ltd.**, Osaka (JP)

(**) Term: **14 Years**

(21) Appl. No.: **29/156,285**

(22) Filed: **Feb. 26, 2002**

(30) **Foreign Application Priority Data**

Aug. 31, 2001 (JP) 2001-025715

(51) **LOC (7) Cl.** **05-02**

(52) **U.S. Cl.** **D15/9**

(58) **Field of Search** D15/7-9; 417/359,
417/360, 410.03, 415, 534; 418/259; 248/635,
638; D23/163, 325, 354

(56) **References Cited**

U.S. PATENT DOCUMENTS

4,938,448 A * 7/1990 Shimazaki 248/635

D435,856 S * 1/2001 Kato D15/9
D440,232 S 4/2001 Kou
D441,378 S 5/2001 Kou
D446,221 S * 8/2001 Kanou et al. D15/9

* cited by examiner

Primary Examiner—Ralf Seifert

(74) *Attorney, Agent, or Firm*—Christensen O'Connor Johnson Kindness PLLC

(57) **CLAIM**

The ornamental design for an electric driven compressor, as shown and described.

DESCRIPTION

FIG. 1 is a perspective view of the top, front and right side of an electric driven compressor showing our new design; FIG. 2 is a front view thereof; FIG. 3 is a rear view thereof; FIG. 4 is a left side view thereof; FIG. 5 is a right side view thereof; FIG. 6 is a top plan view thereof; and, FIG. 7 is a bottom view thereof.

The element shown in phantom lines do not form any part of the claimed design.

1 Claim, 4 Drawing Sheets

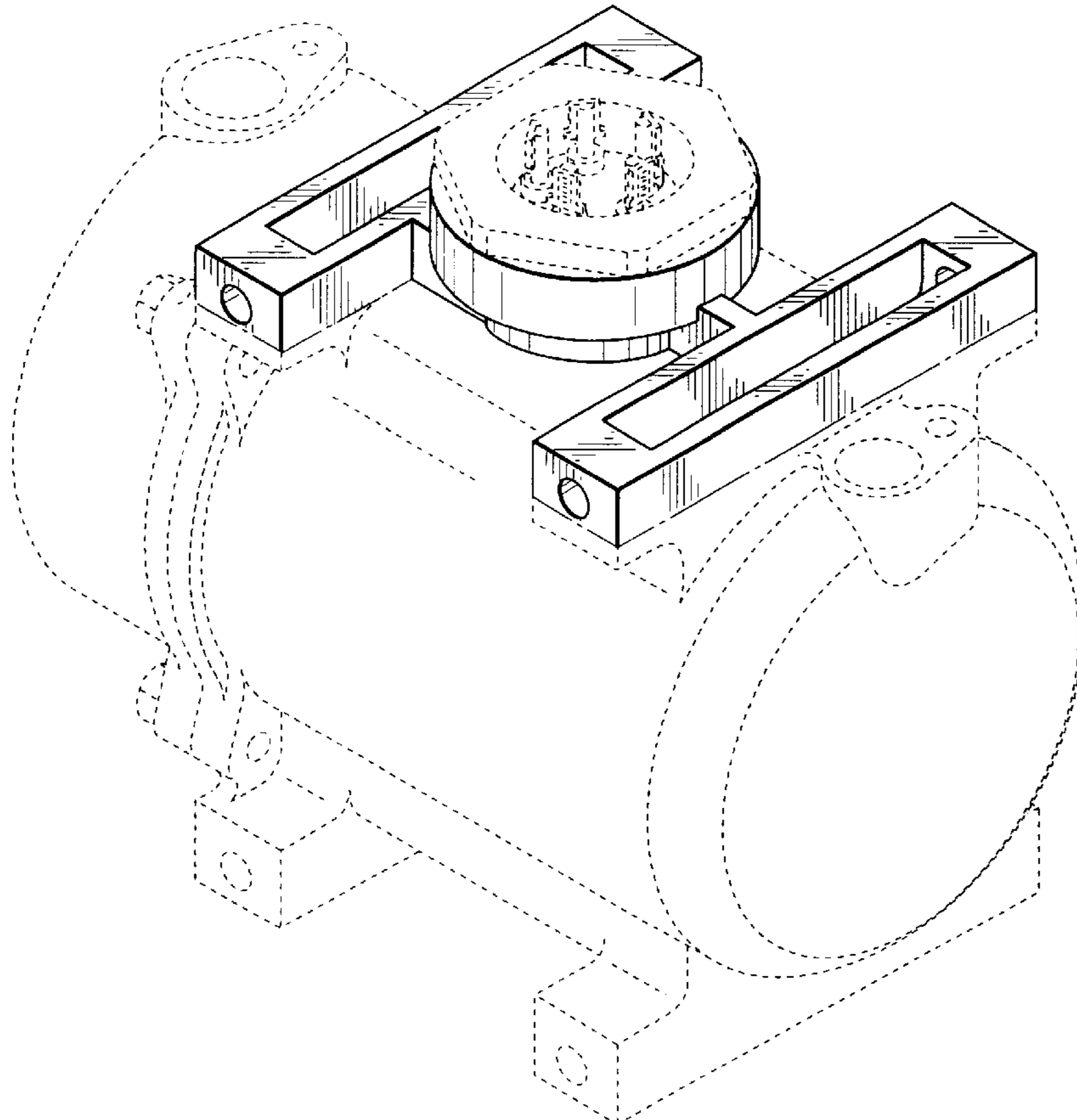

FIG. 1

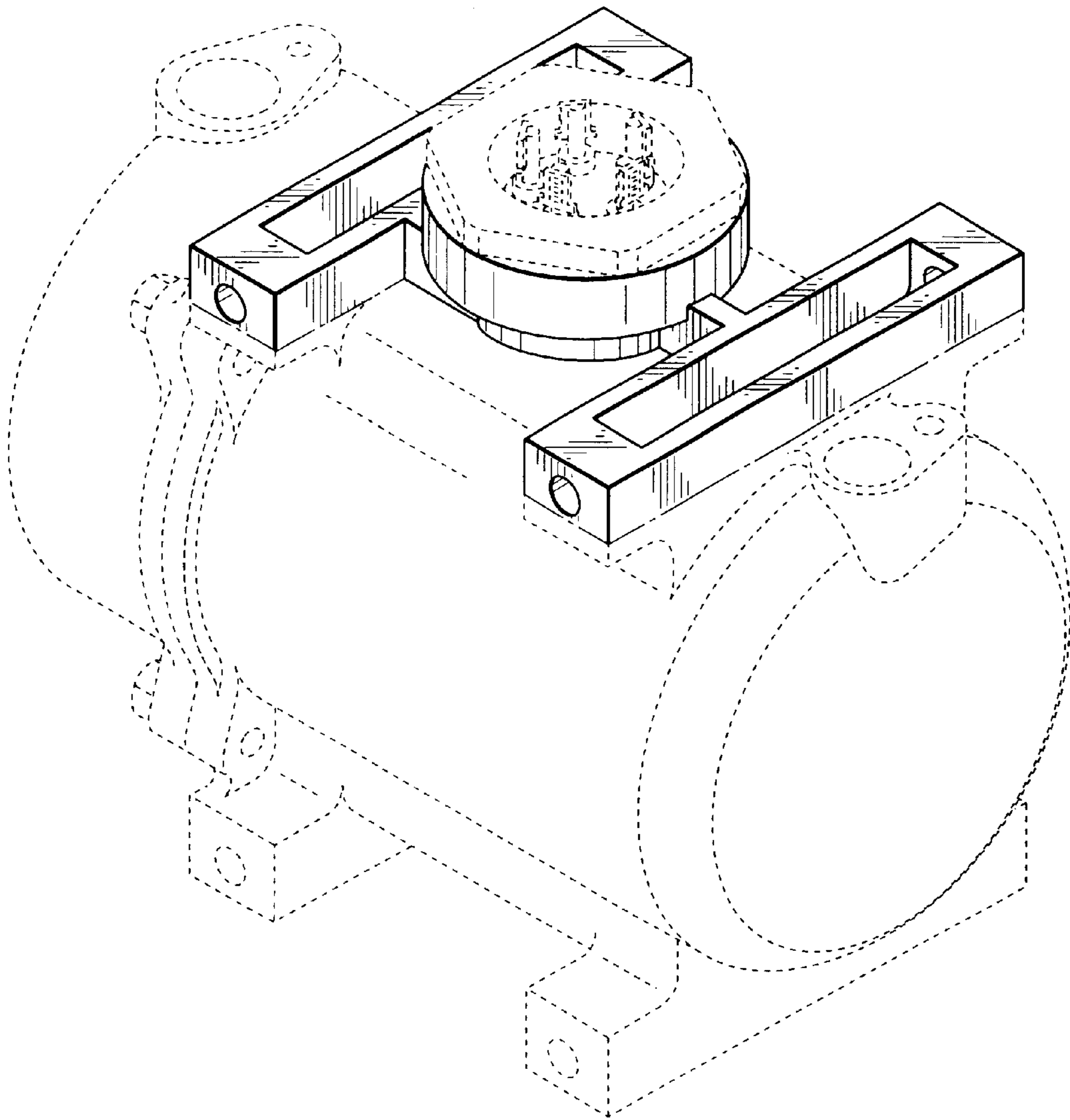

FIG. 2

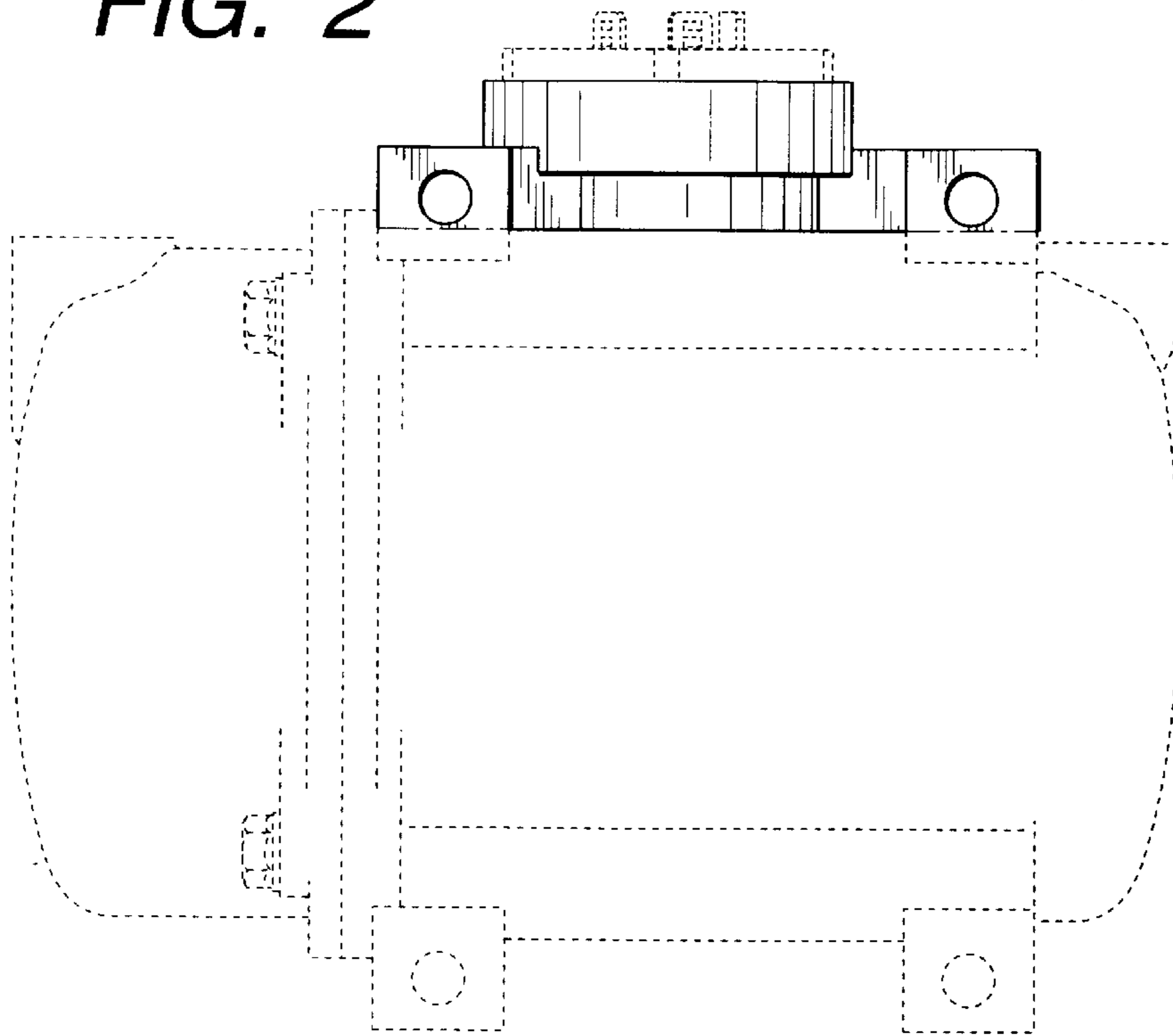

FIG. 3

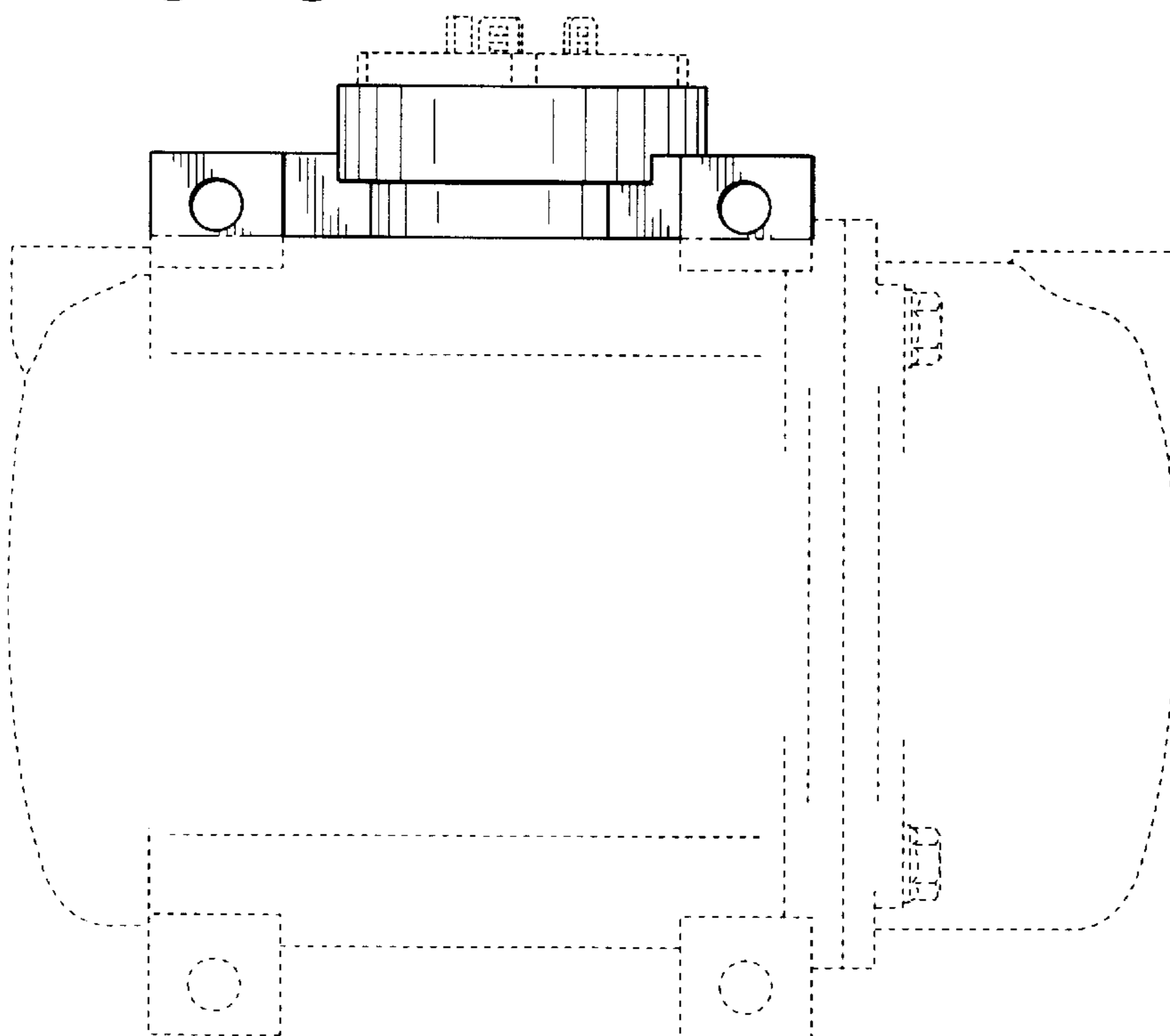

FIG. 4

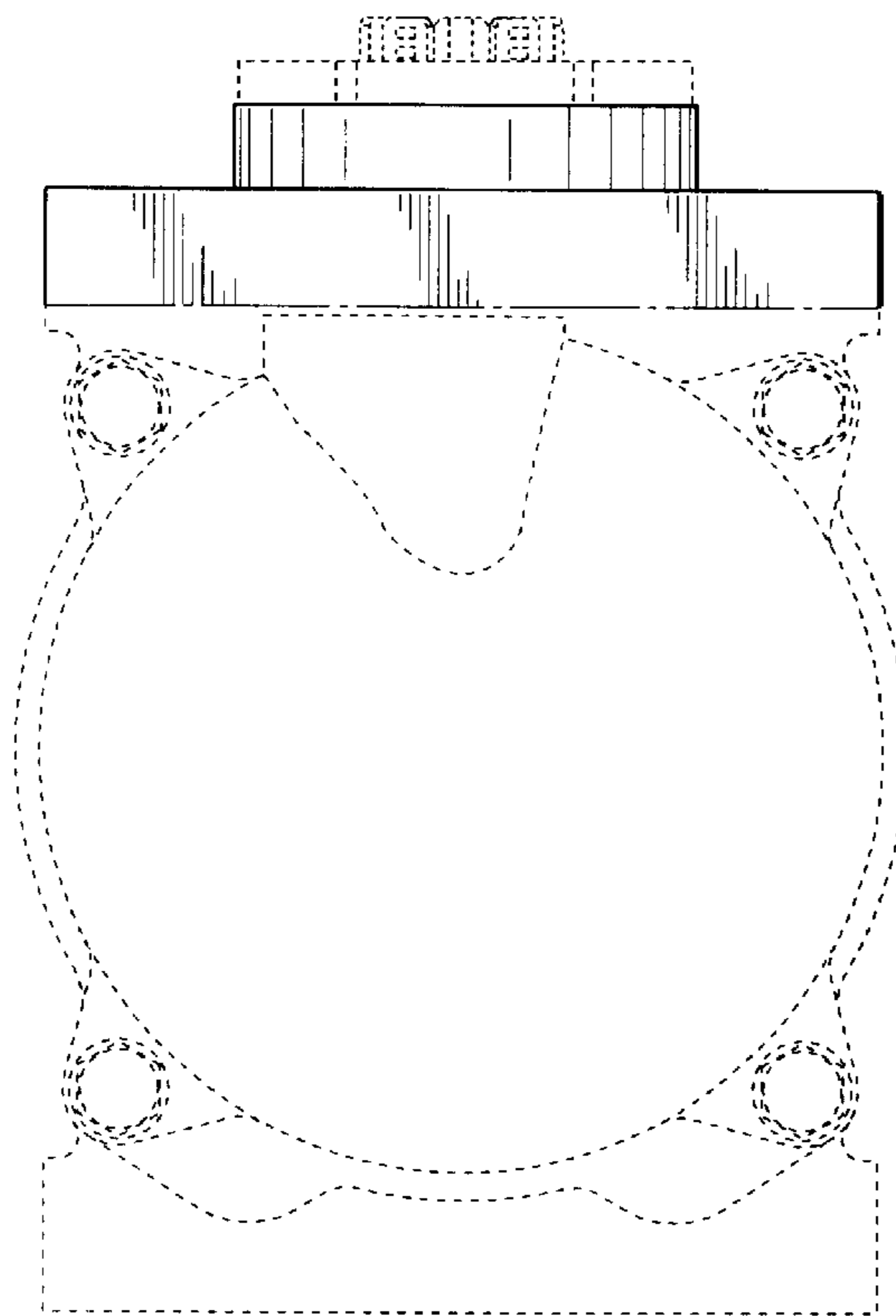

FIG. 5

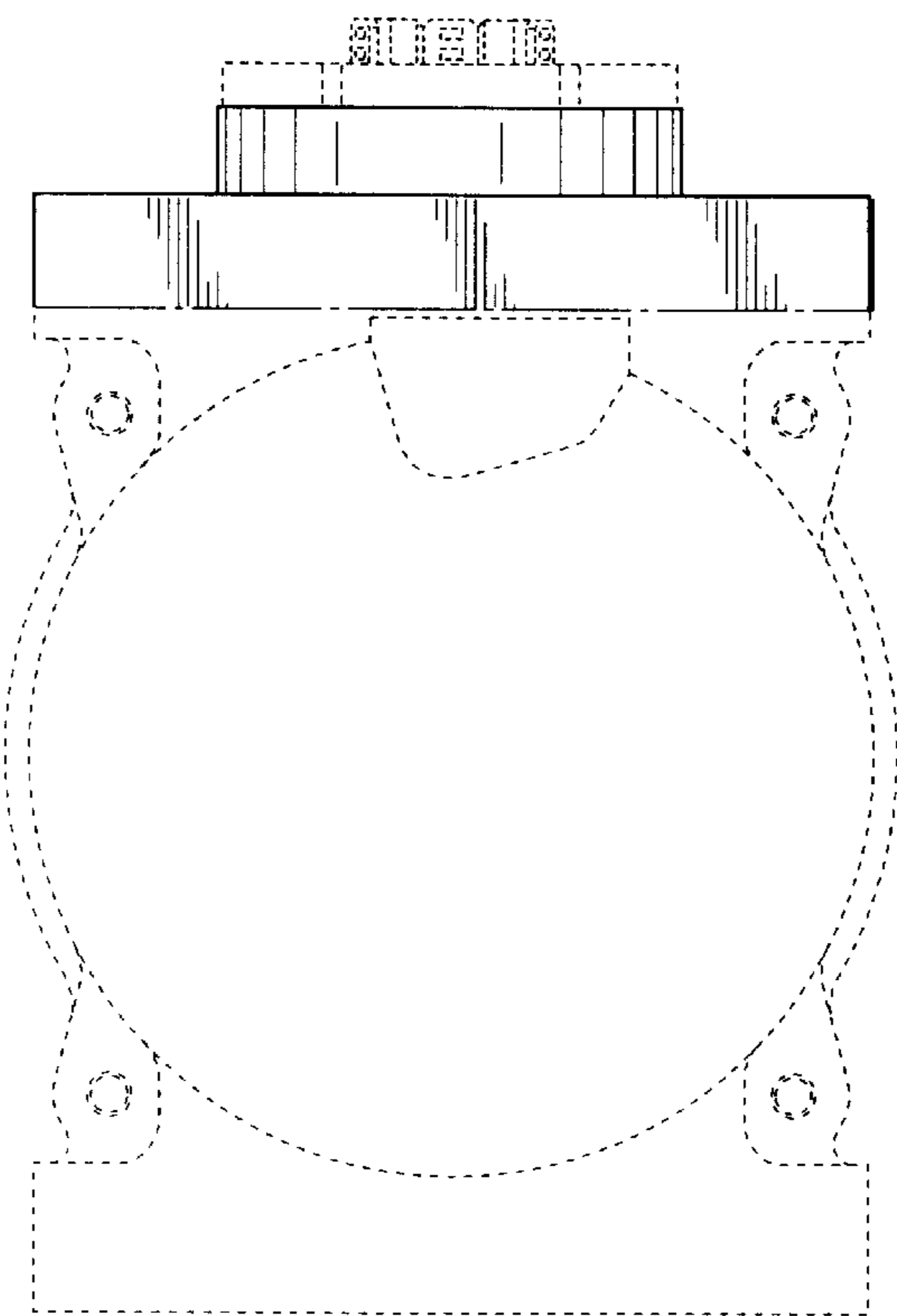

FIG. 6

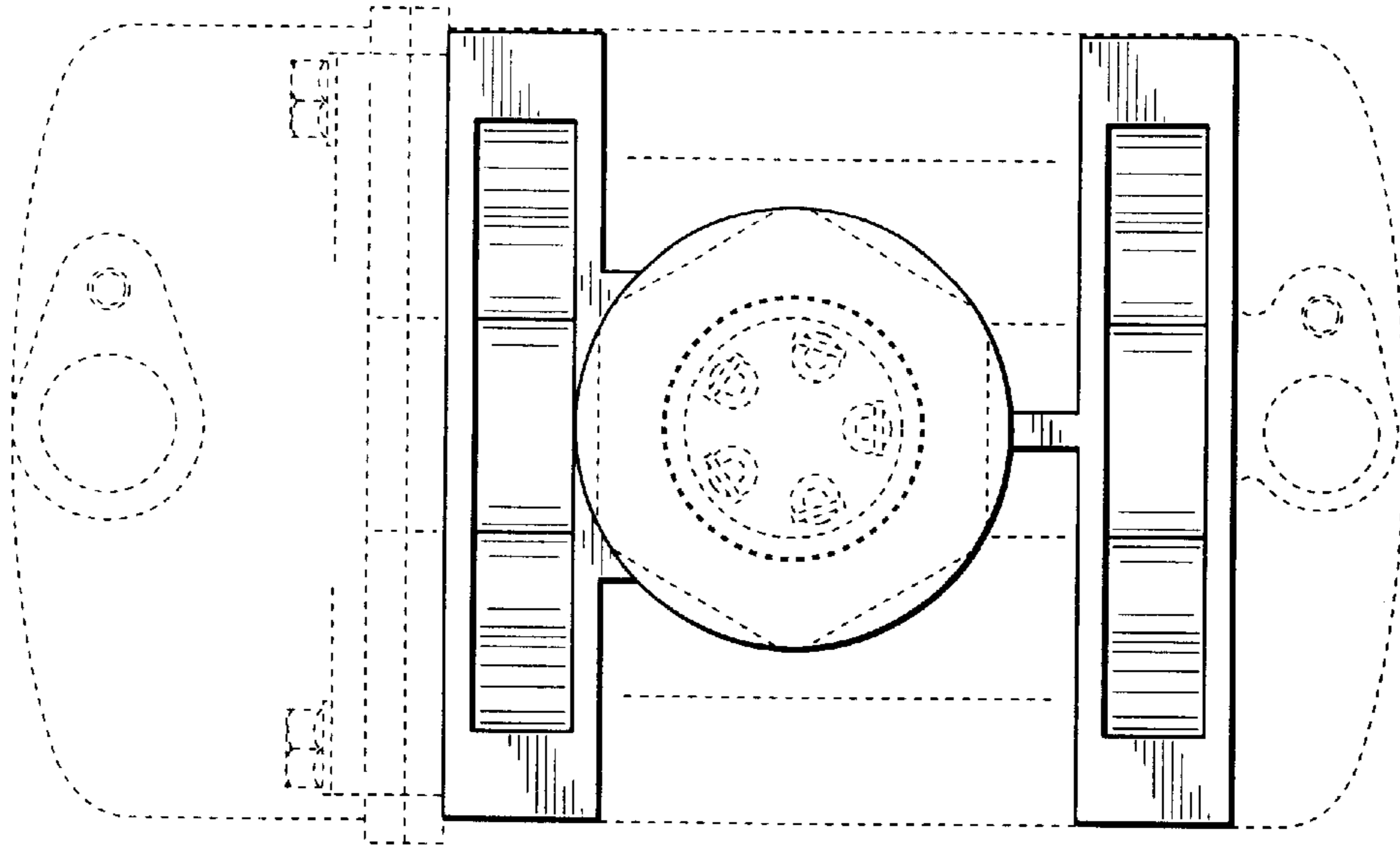

FIG. 7

