



US00D466454S

(12) **United States Design Patent** (10) **Patent No.:** **US D466,454 S**
Kalhok et al. (45) **Date of Patent:** **** Dec. 3, 2002**

(54) **FRONT FENDERS OF AN ALL TERRAIN VEHICLE**

(75) Inventors: **David Kalhok**, Marion, IL (US); **Pierre Rondeau**, St-Denis-de-Brompton (CA); **Martin Portelance**, Sherbrooke (CA)

(73) Assignee: **Bombardier Inc.**, Valcourt (CA)

(**) Term: **14 Years**

(21) Appl. No.: **29/152,482**

(22) Filed: **Dec. 5, 2001**

Related U.S. Application Data

(62) Division of application No. 29/123,530, filed on May 19, 2000.

(51) **LOC (7) Cl.** **12-16**

(52) **U.S. Cl.** **D12/184**

(58) **Field of Search** D12/107, 185, D12/184, 186; 280/847-851, 154, 152.1, 152.3

(56) **References Cited**

U.S. PATENT DOCUMENTS

D298,744 S 11/1988 Saito et al.
D327,457 S 6/1992 Saito

(List continued on next page.)

OTHER PUBLICATIONS

Honda Motorcycles, 1986 FourTrax 250R, www.hondamotorcycle.com/classics/1986fourtrax250r/index.html, 3 pages.

Yamaha Motorcycles, www.yamaha-motor.com/01motorsports/01atv/gallerybody.html, 3 pages.

Bombardier Parts Catalog 2000, DS 650, Nov. 1999, 704 300 001.

Primary Examiner—Melody N. Brown
(74) *Attorney, Agent, or Firm*—Pillsbury Winthrop LLP

(57) **CLAIM**

The ornamental design of front fenders of an all terrain vehicle, as shown and described.

DESCRIPTION

FIG. 1 is a perspective illustration, from the front and right side, of a first embodiment of a right front fender of the all terrain vehicle of our design;
FIG. 2 is a left side view thereof;
FIG. 3 is a right side view thereof;
FIG. 4 is a top view thereof;
FIG. 5 is a front view thereof;
FIG. 6 is a rear view thereof;
FIG. 7 is a left side view of a first embodiment of a left front fender of the all terrain vehicle of our design;
FIG. 8 is a right side view thereof;
FIG. 9 is a top view thereof;
FIG. 10 is a front view thereof;
FIG. 11 is a rear view thereof;
FIG. 12 is a perspective illustration, from the front and right side, of a second embodiment of a right front fender of the all terrain vehicle of our design;
FIG. 13 is a left side view thereof;
FIG. 14 is a right side view thereof;
FIG. 15 is a top view thereof;
FIG. 16 is a front view thereof;
FIG. 17 is a rear view thereof;
FIG. 18 is a left side view of a second embodiment of a left front fender of the all terrain vehicle of our design;
FIG. 19 is a right side view thereof;
FIG. 20 is a top view thereof;
FIG. 21 is a front view thereof; and,
FIG. 22 is a rear view thereof.

Throughout the various figures of the drawings, certain views are not provided. The omission of a particular view is intended to convey that the element(s) depicted is/are plain and unornamented in that omitted view.

Where included, broken lines showing environment or structure are for illustrative purposes only and form no part of the claimed design.

1 Claim, 6 Drawing Sheets

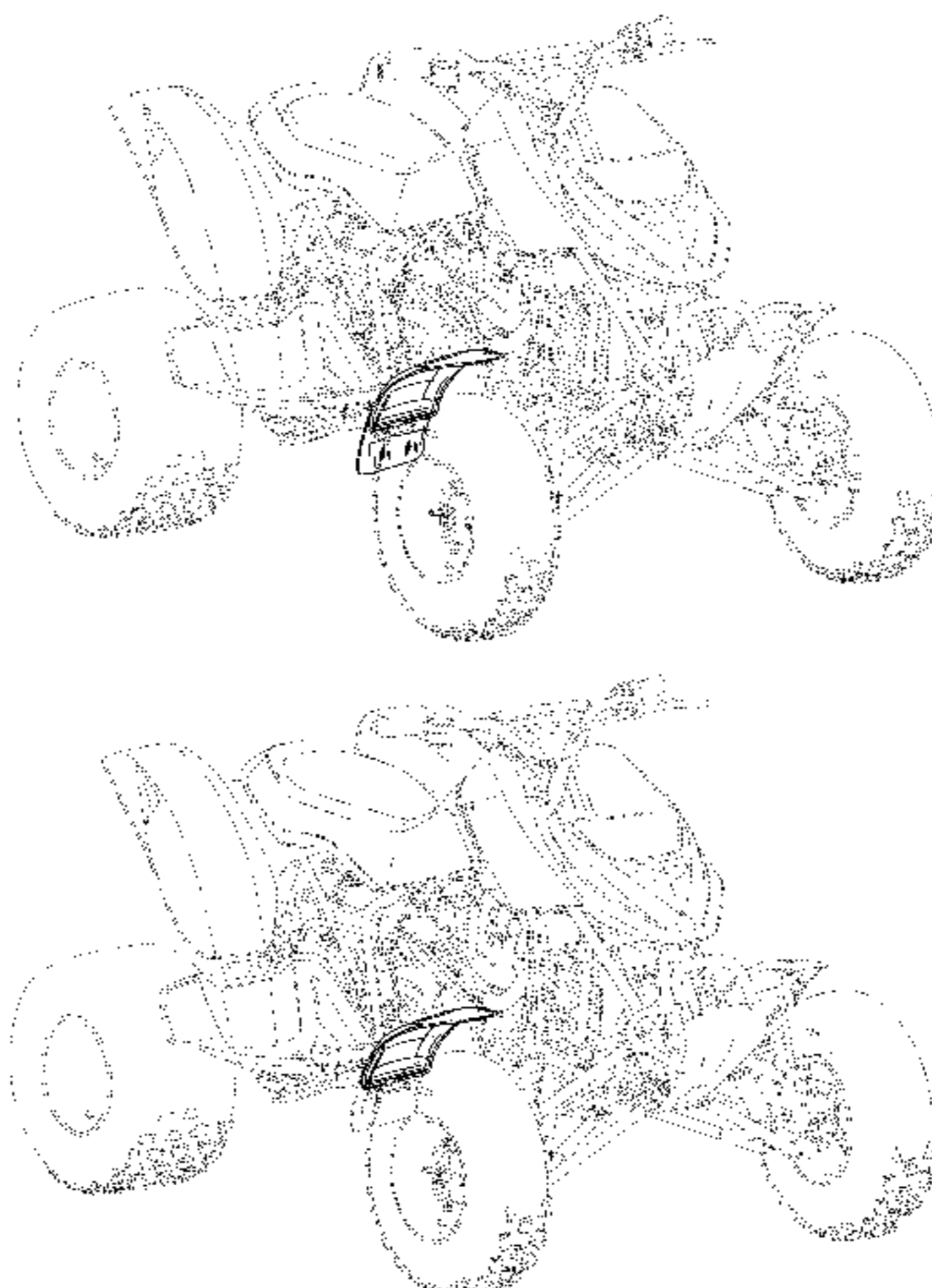

US D466,454 S

Page 2

U.S. PATENT DOCUMENTS

D330,694 S	11/1992	Kimura et al.	
D344,059 S	* 2/1994	De Braal et al.	D12/184
D347,614 S	* 6/1994	De Braal et al.	D12/184
D412,464 S	8/1999	Ichihara et al.	
D427,942 S	7/2000	Cho et al.	
D438,823 S	3/2001	Luh	
D448,325 S	* 9/2001	Fujieda	D12/107
D452,835 S	* 1/2002	Aoki et al.	D12/107

* cited by examiner

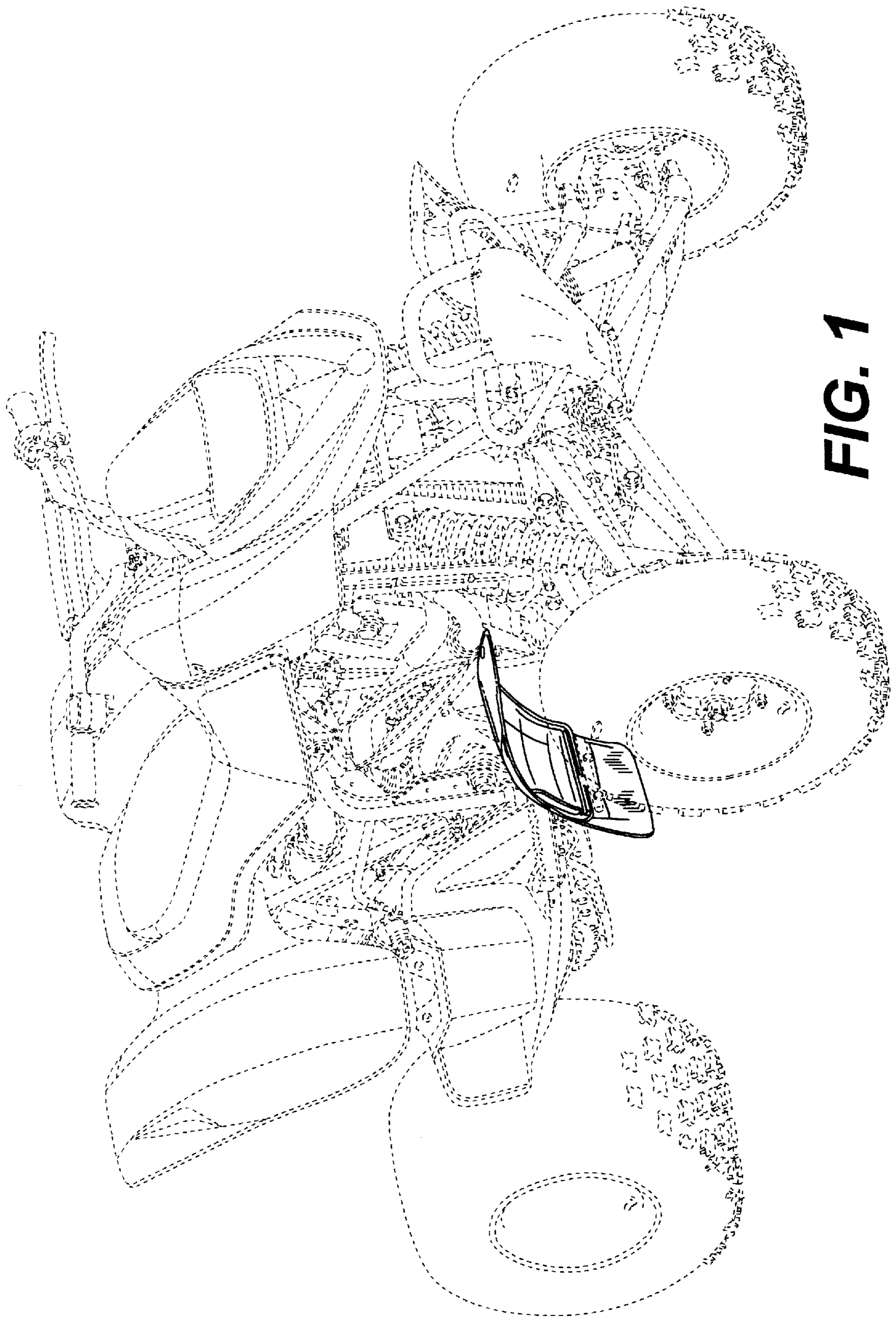

FIG. 1

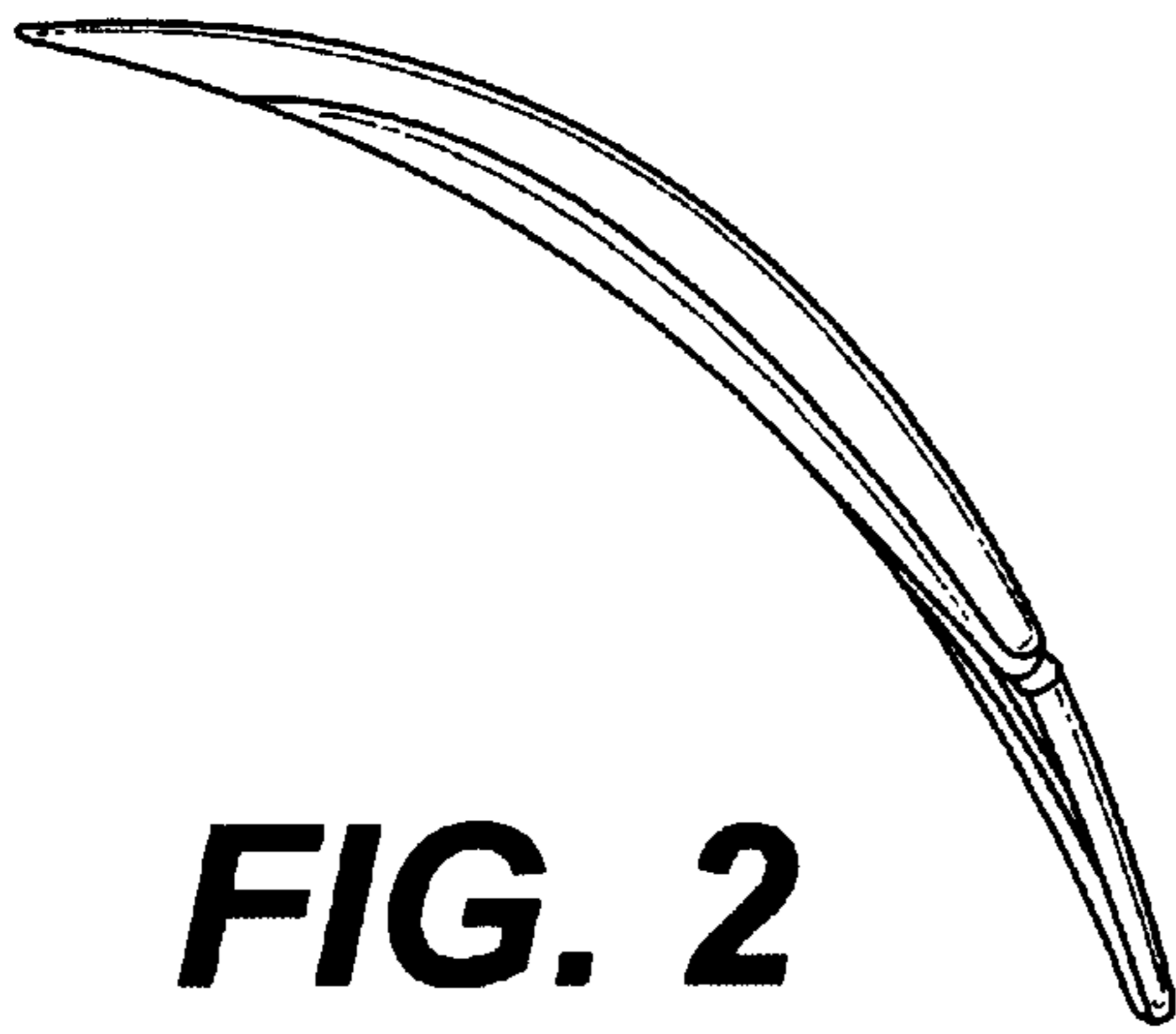

FIG. 2

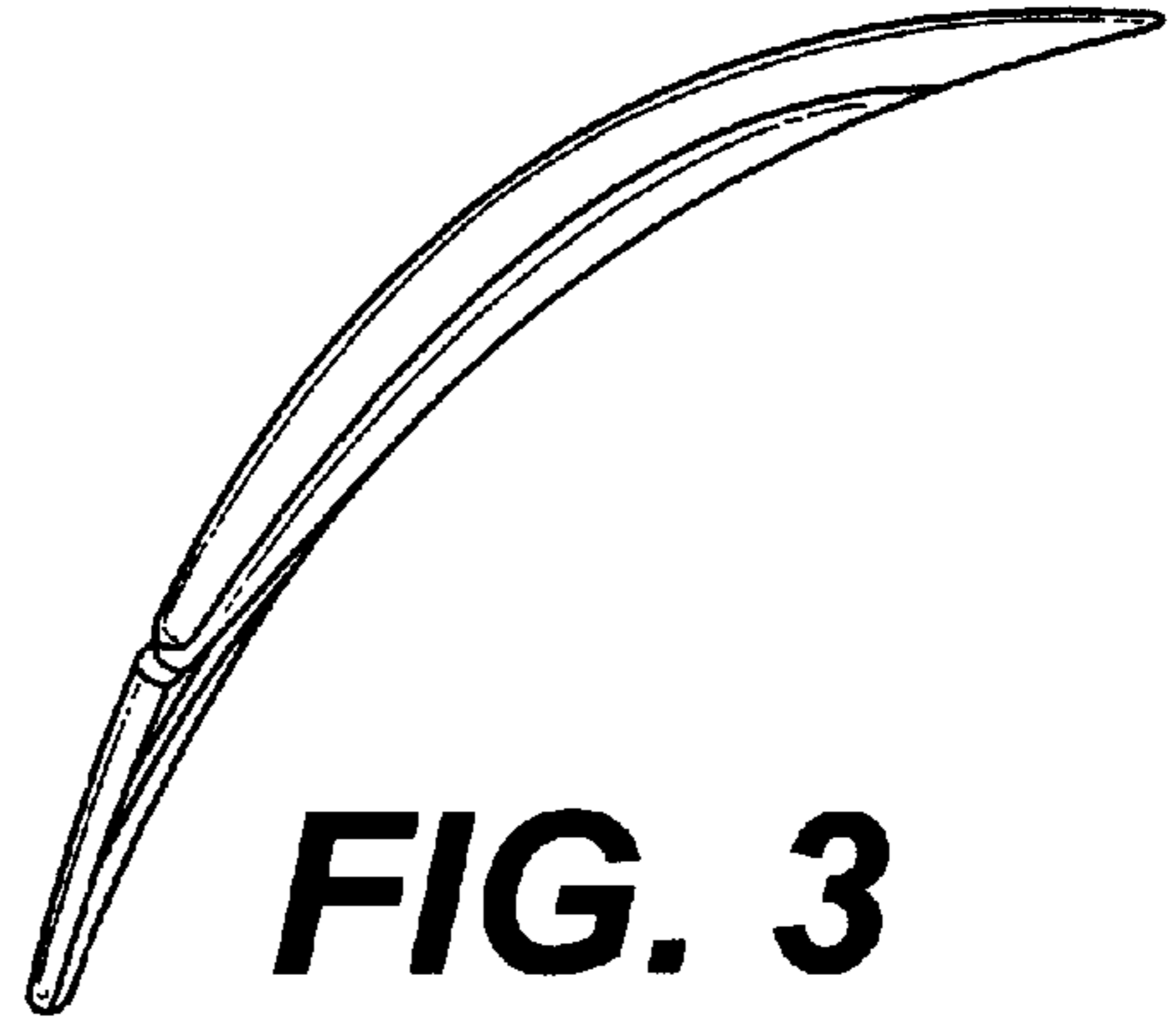

FIG. 3

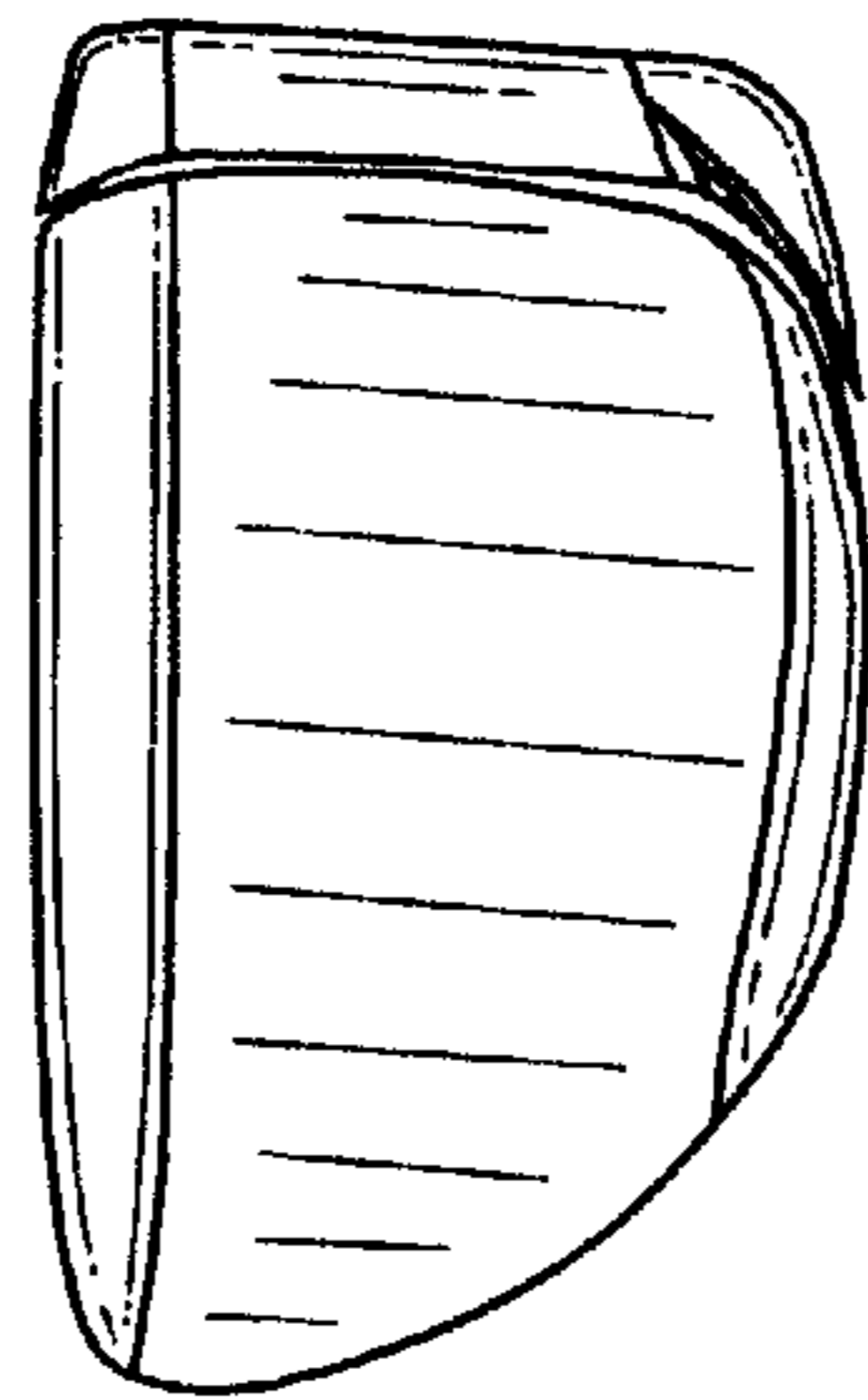

FIG. 4

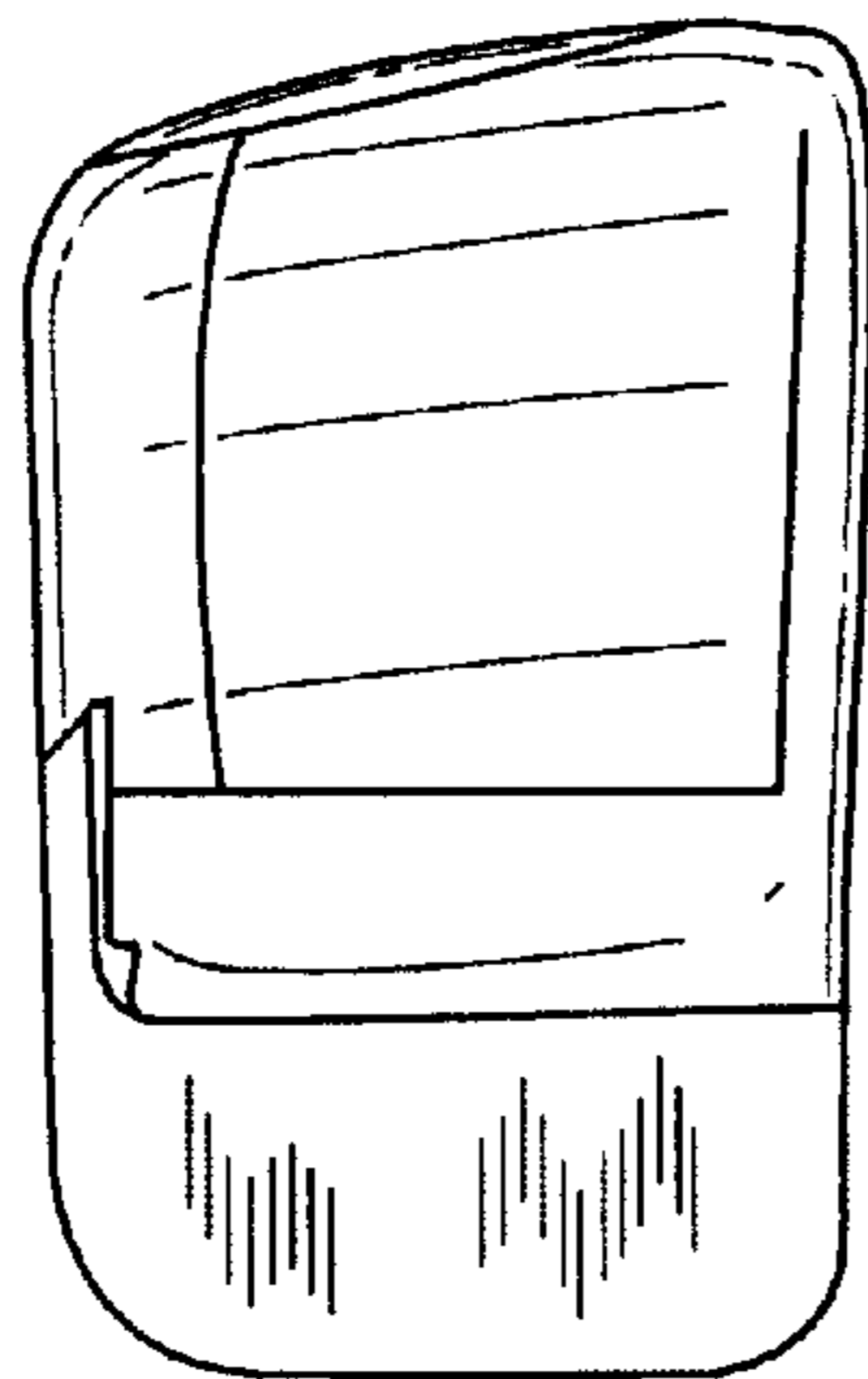

FIG. 5

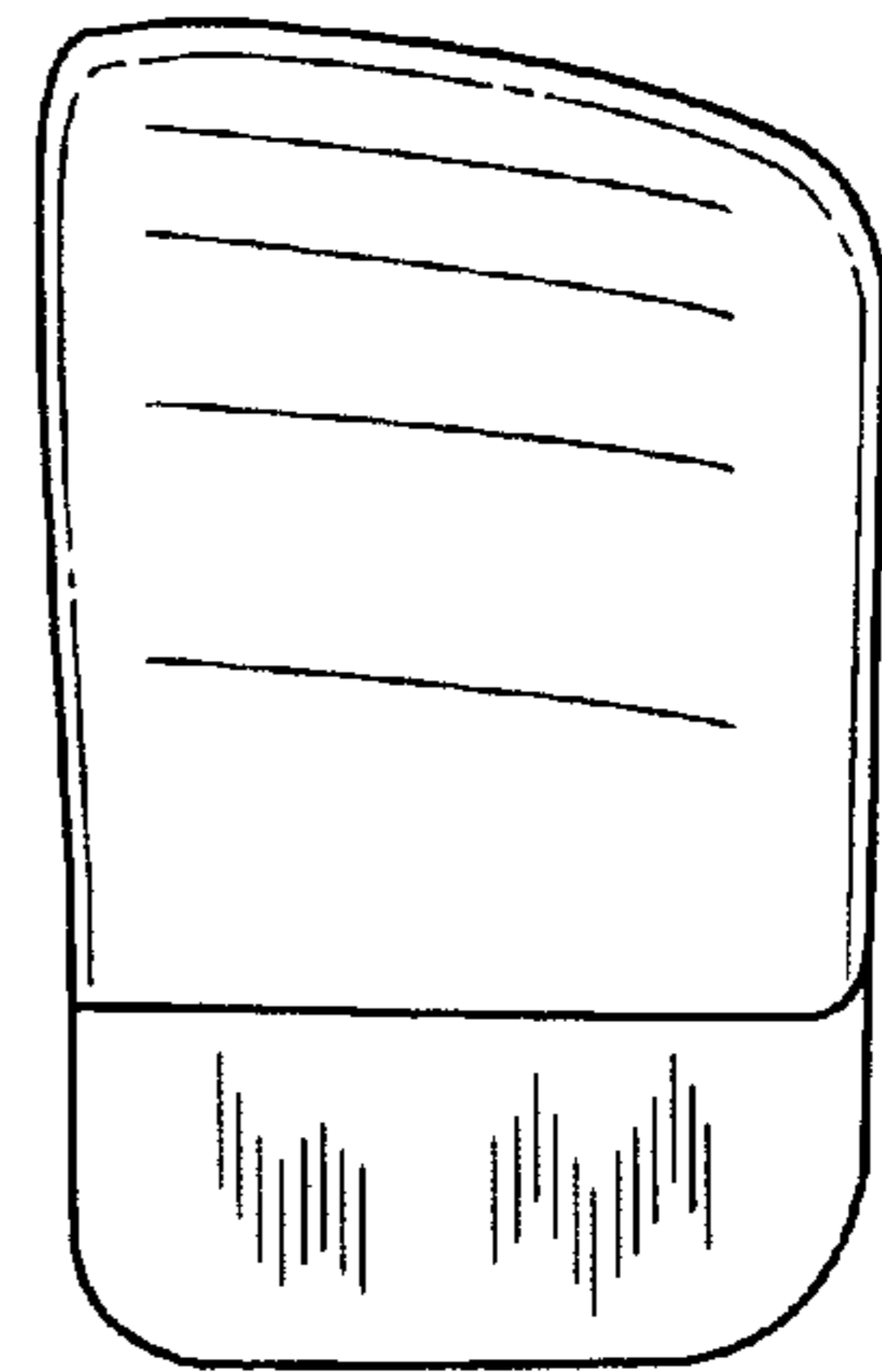

FIG. 6

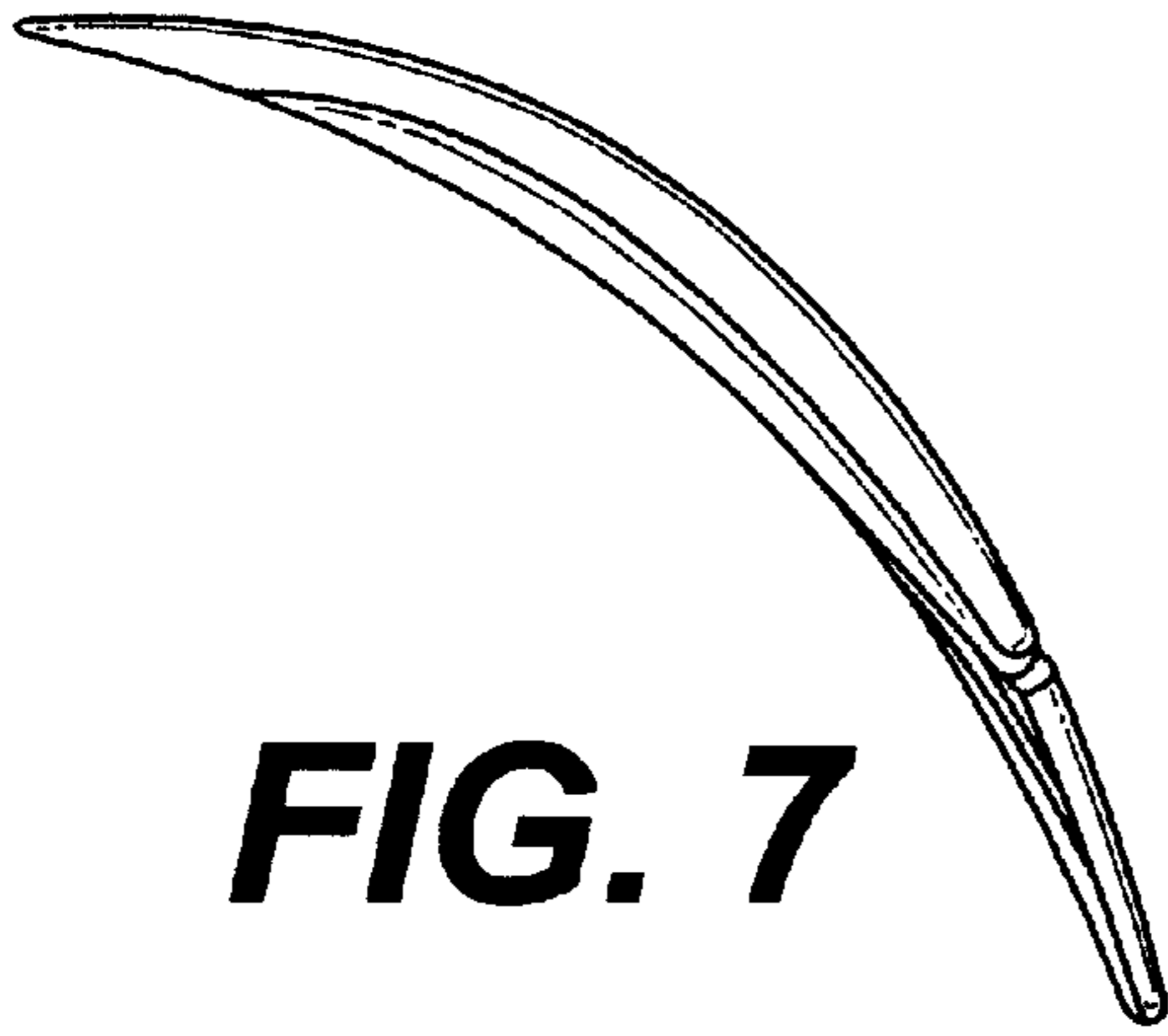

FIG. 7

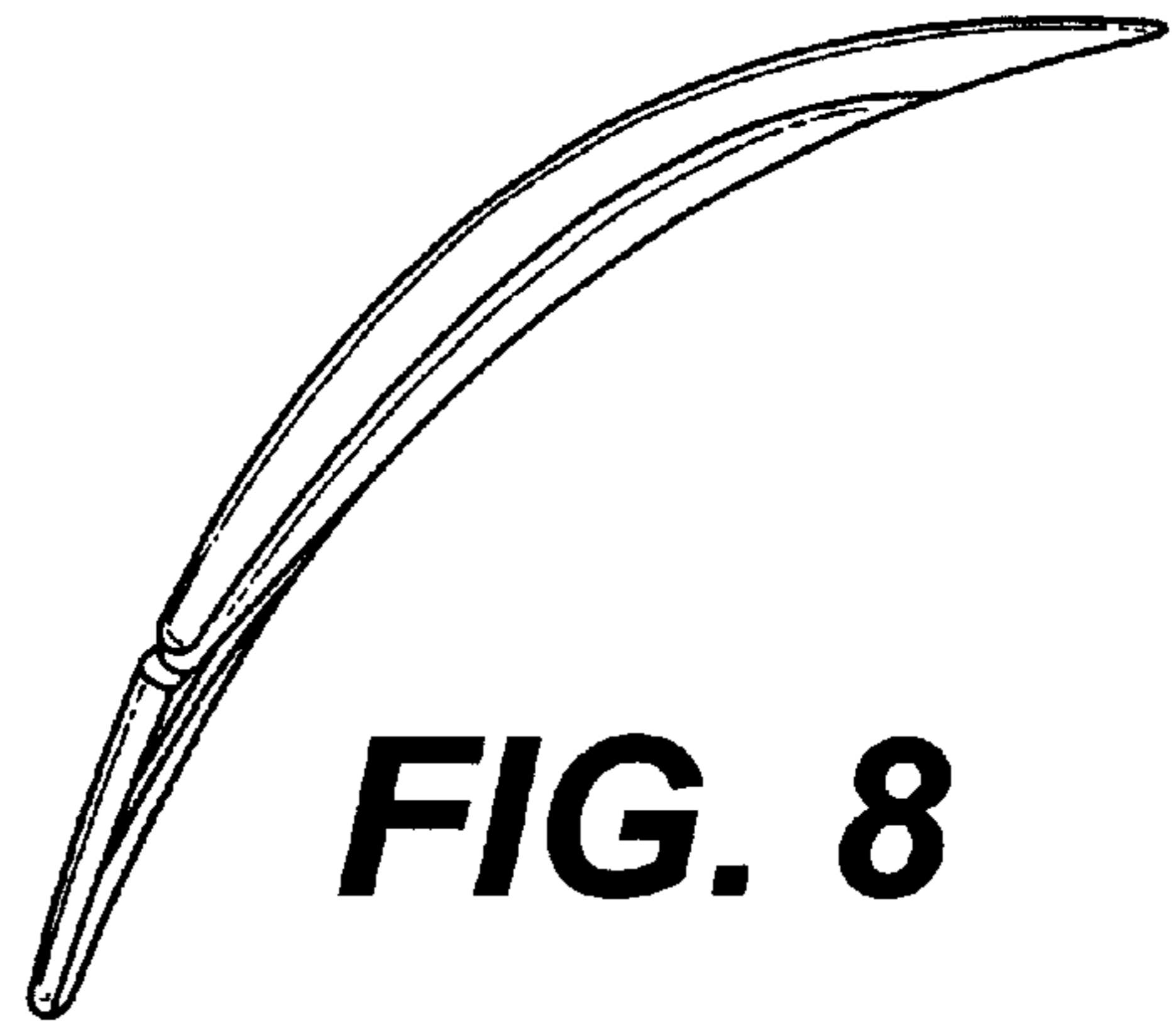

FIG. 8

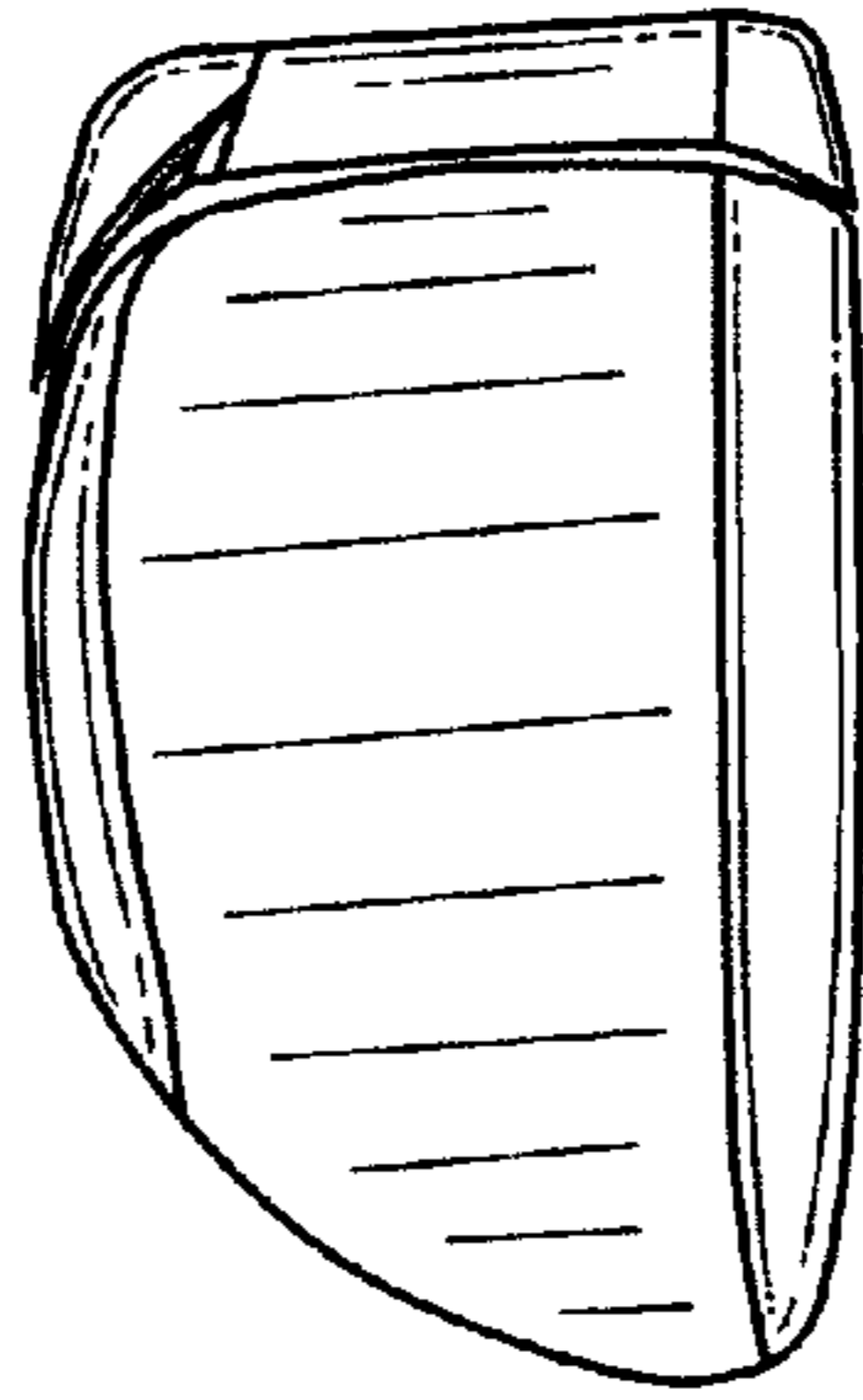

FIG. 9

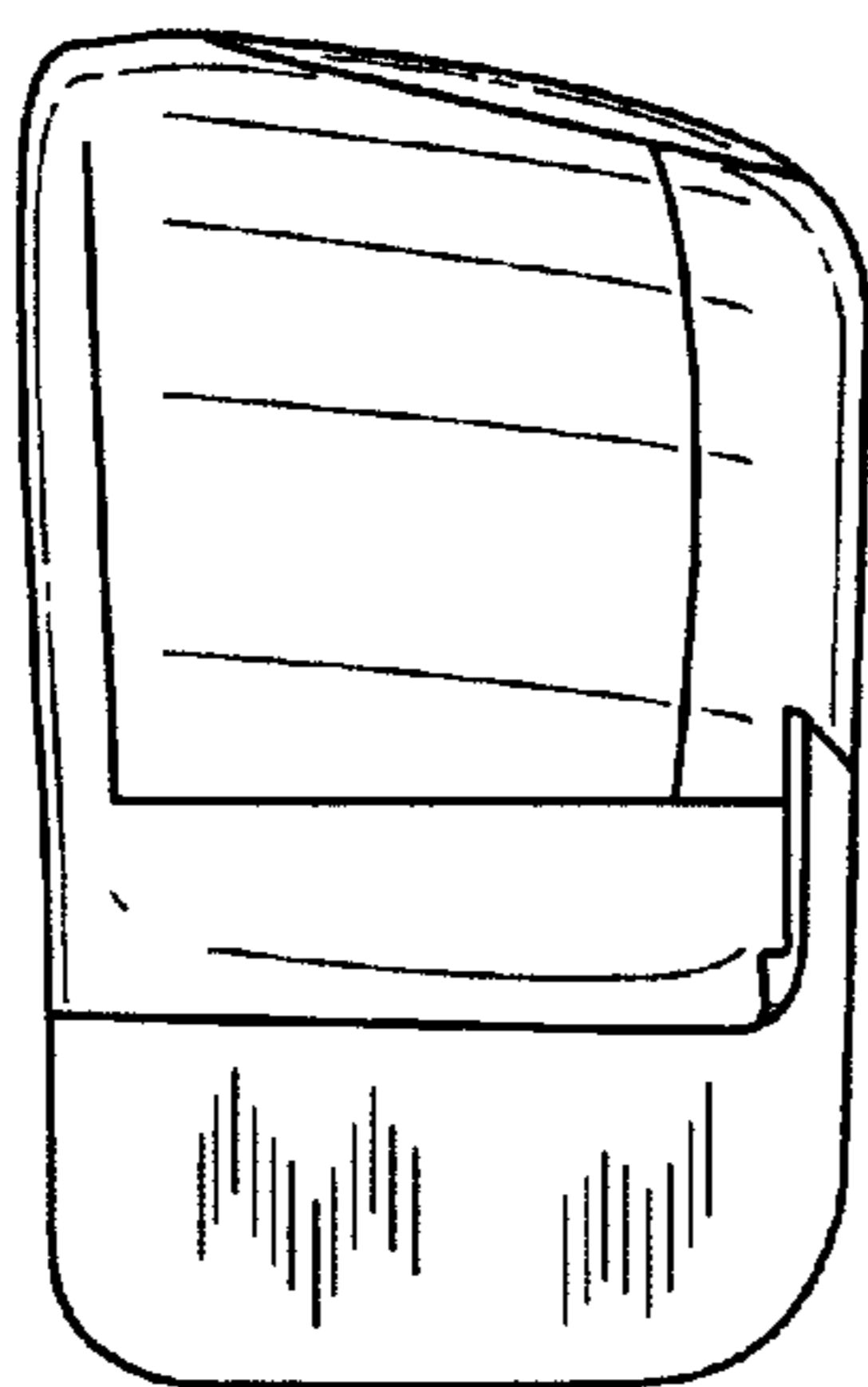

FIG. 10

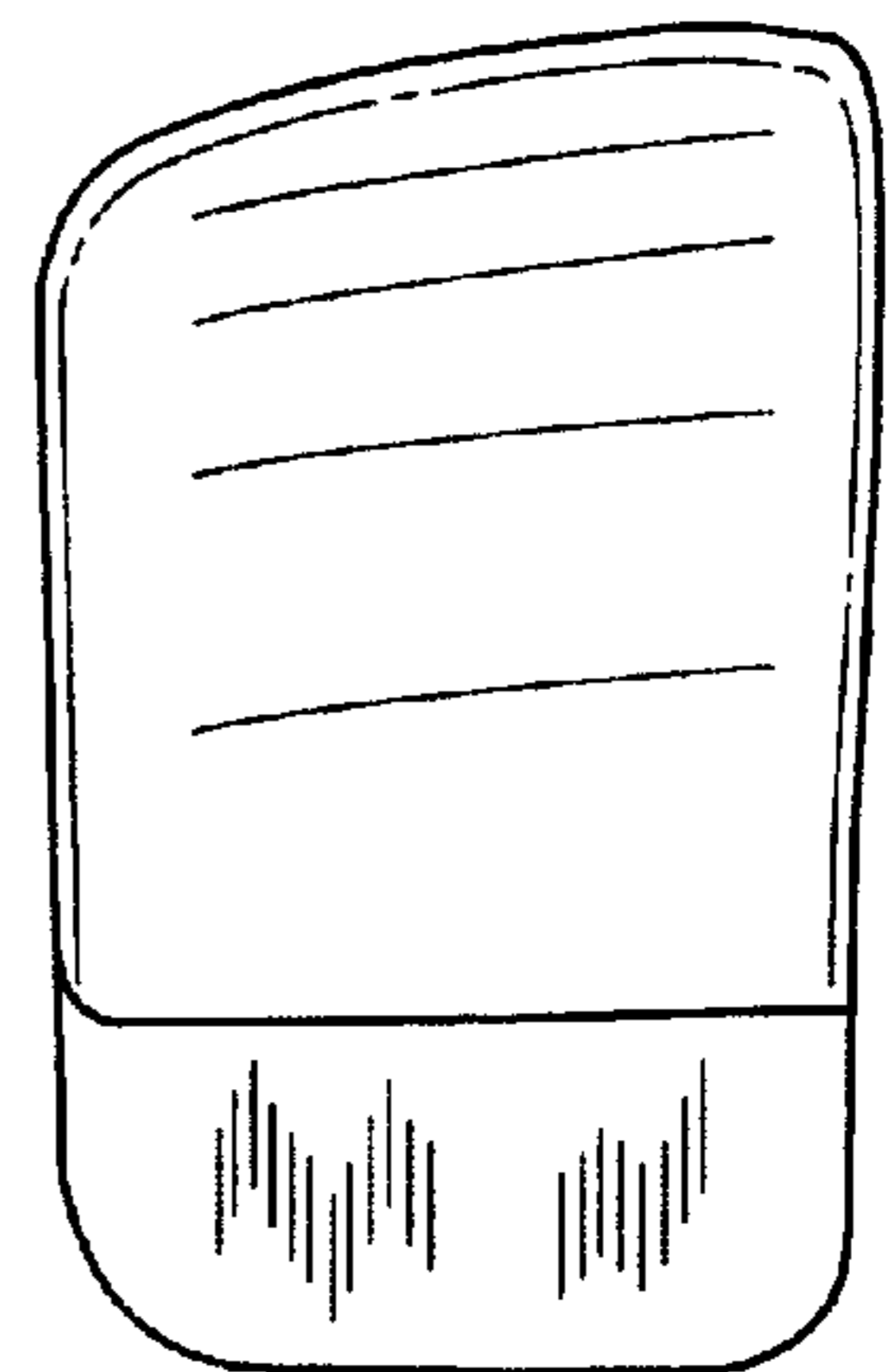

FIG. 11

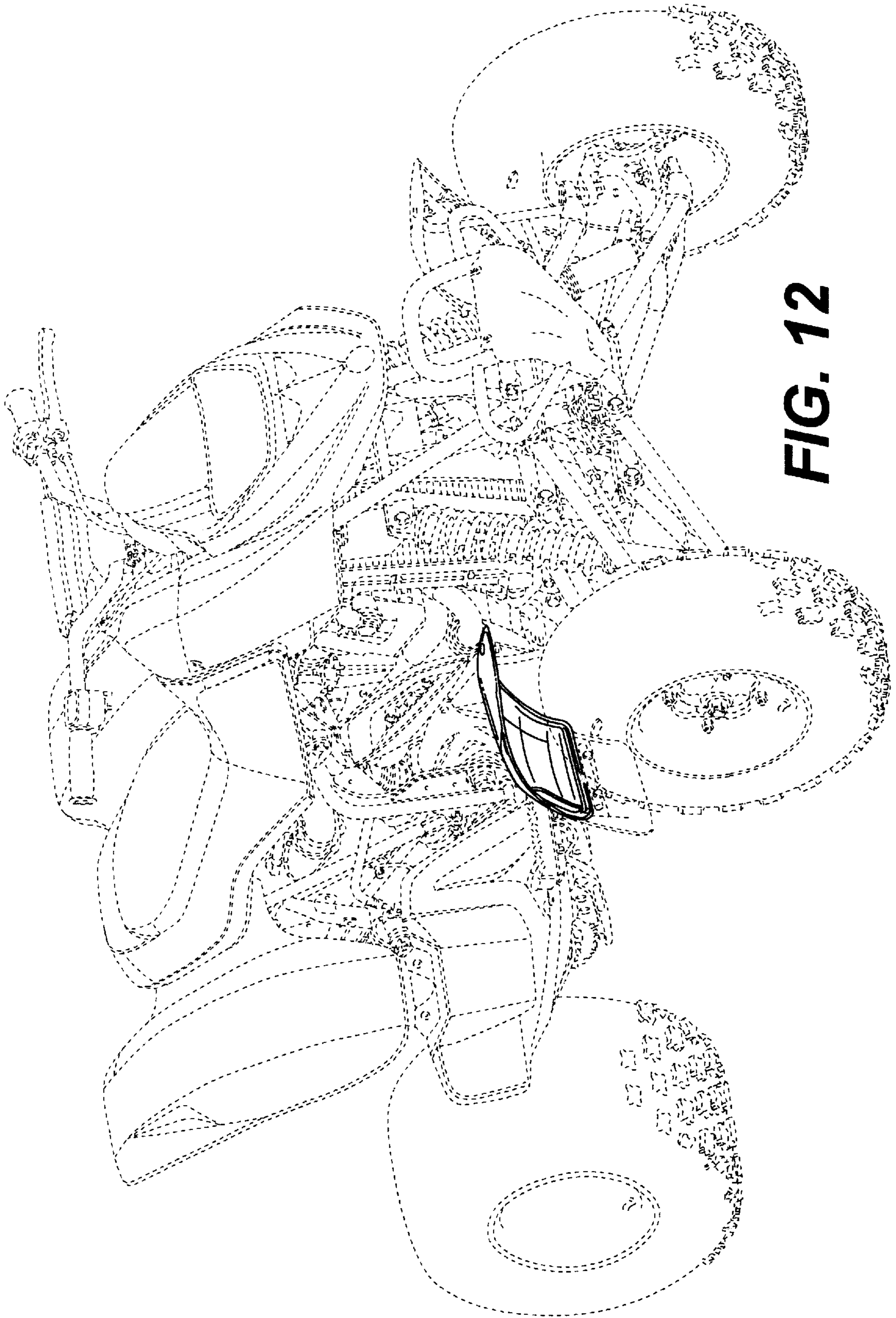

FIG. 12



FIG. 13

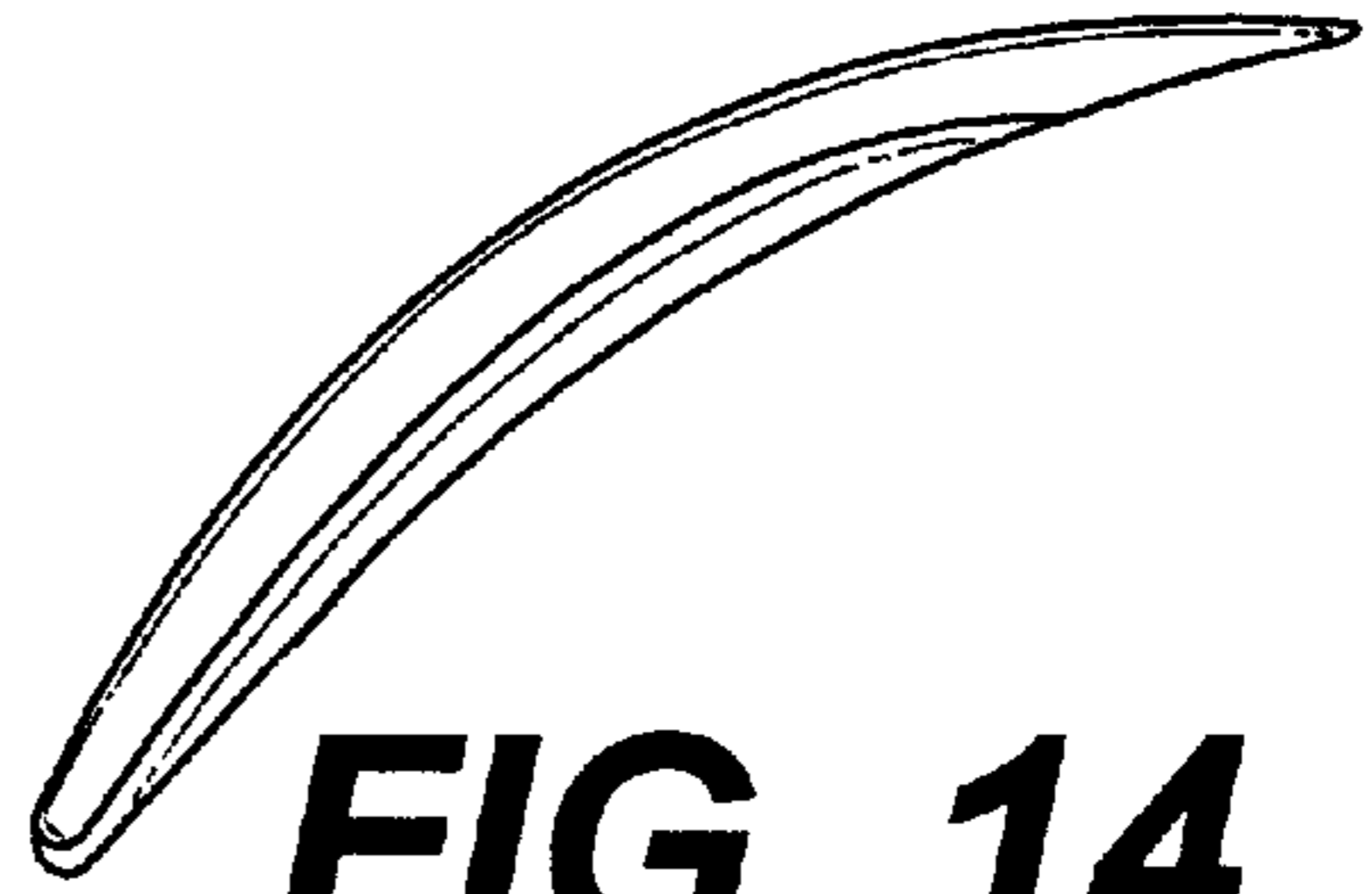

FIG. 14

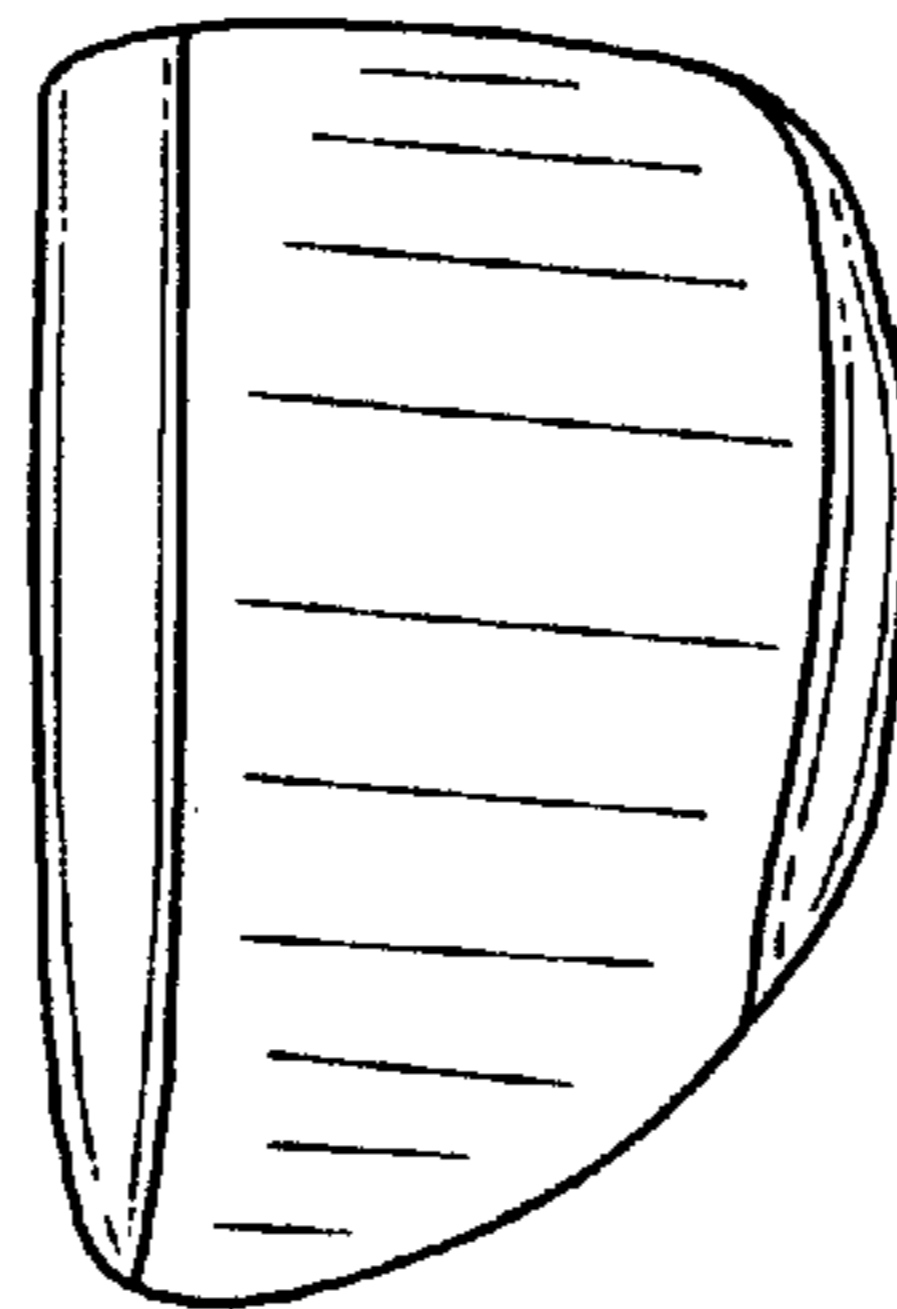

FIG. 15

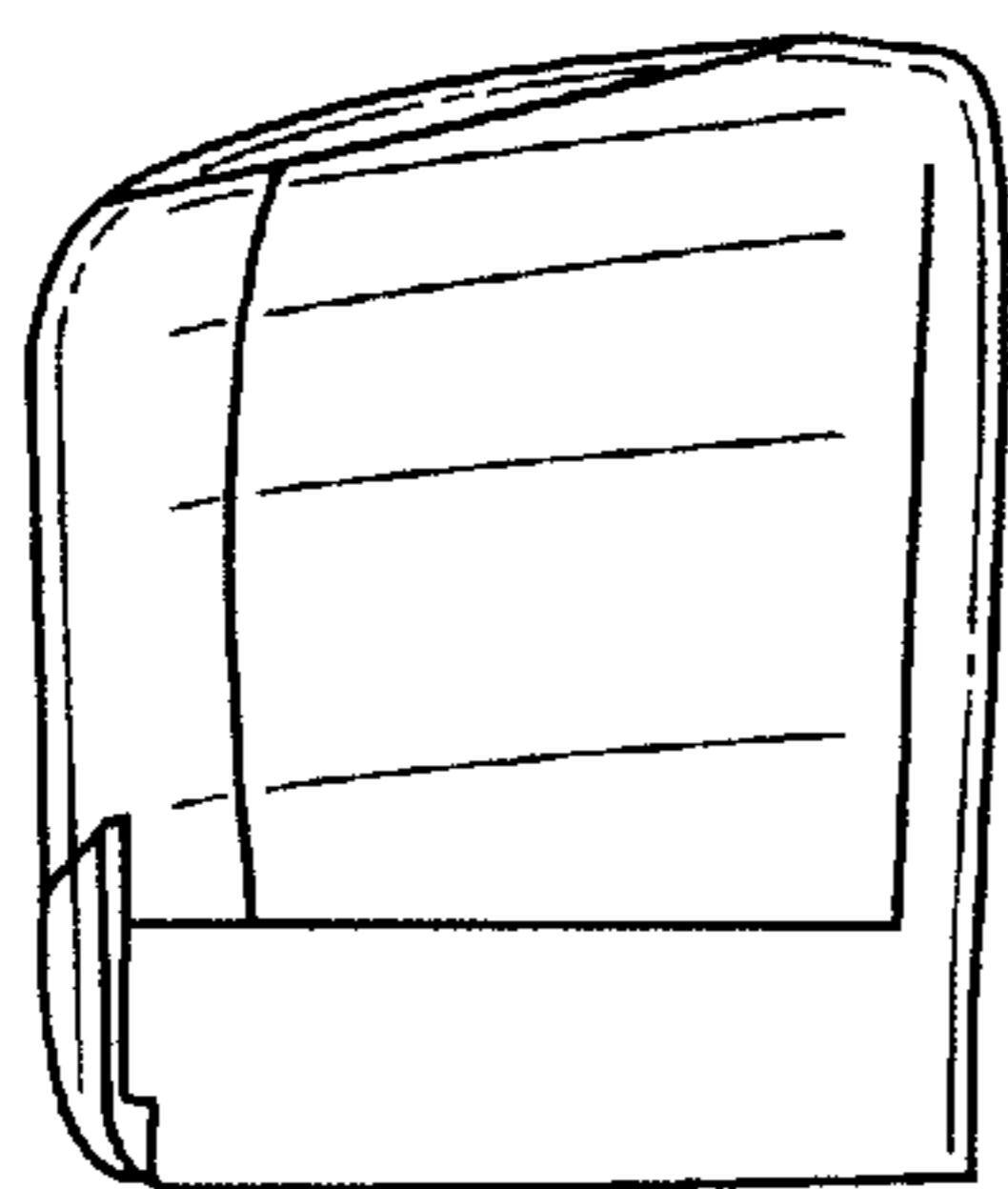

FIG. 16

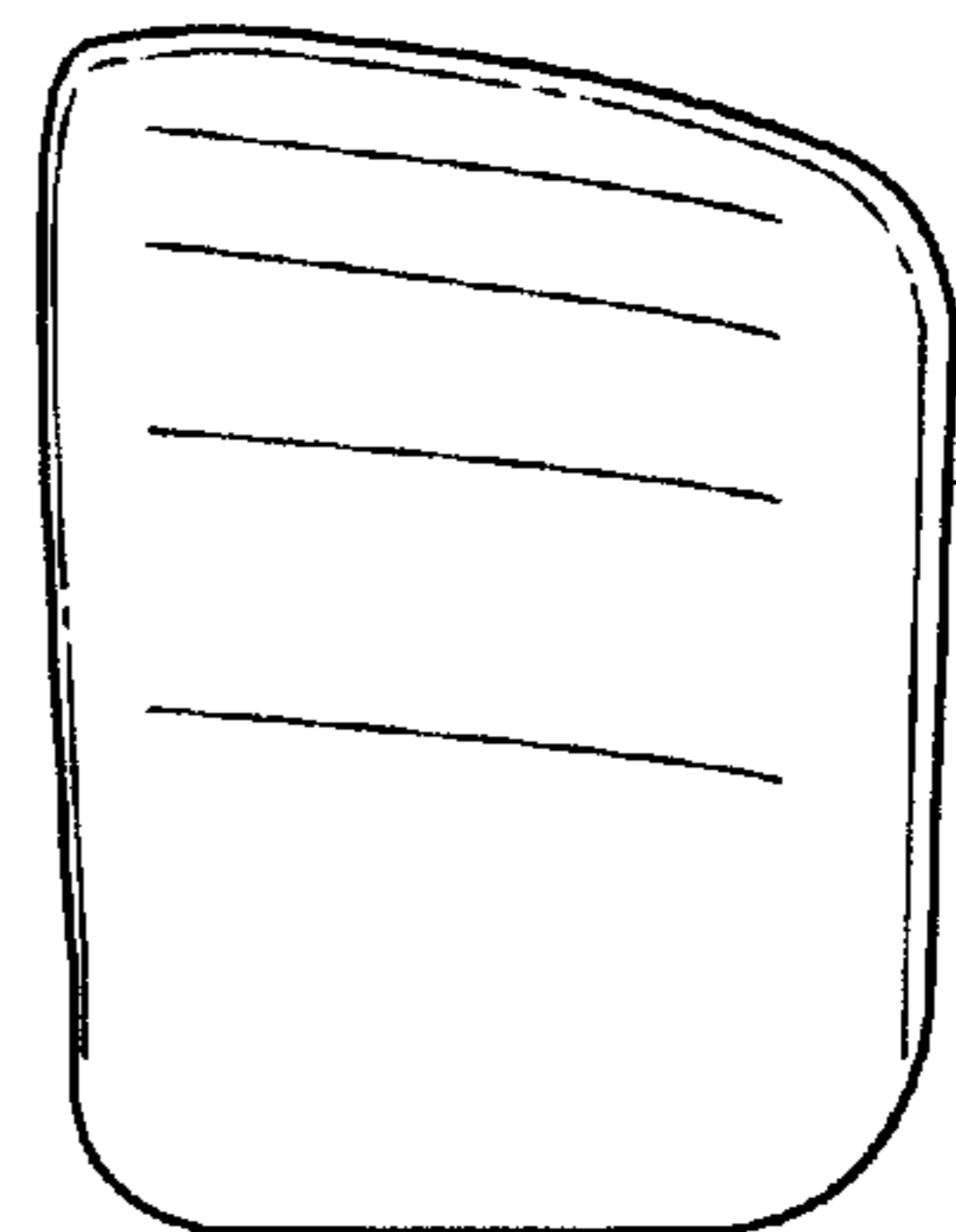

FIG. 17

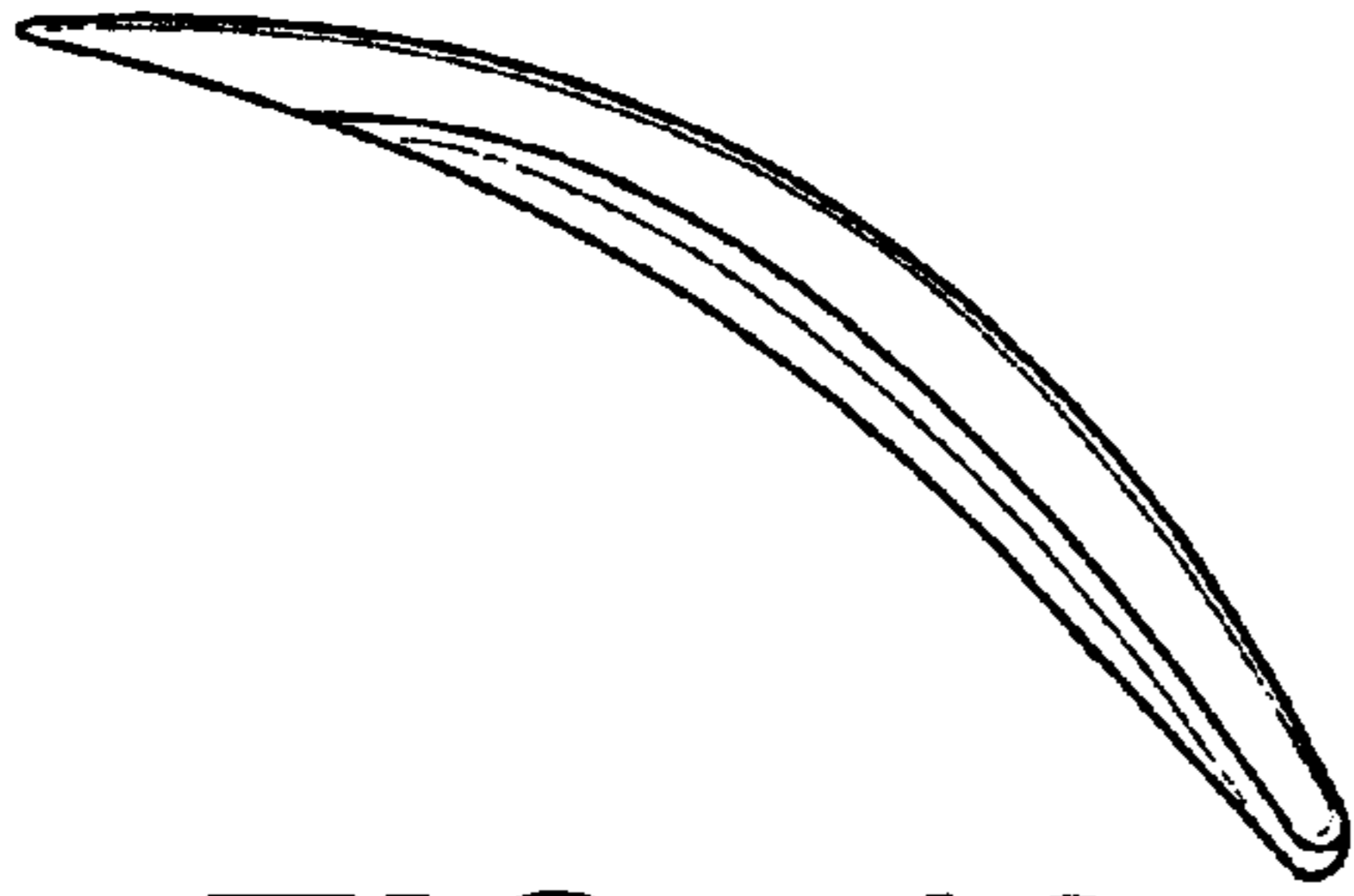

FIG. 18



FIG. 19

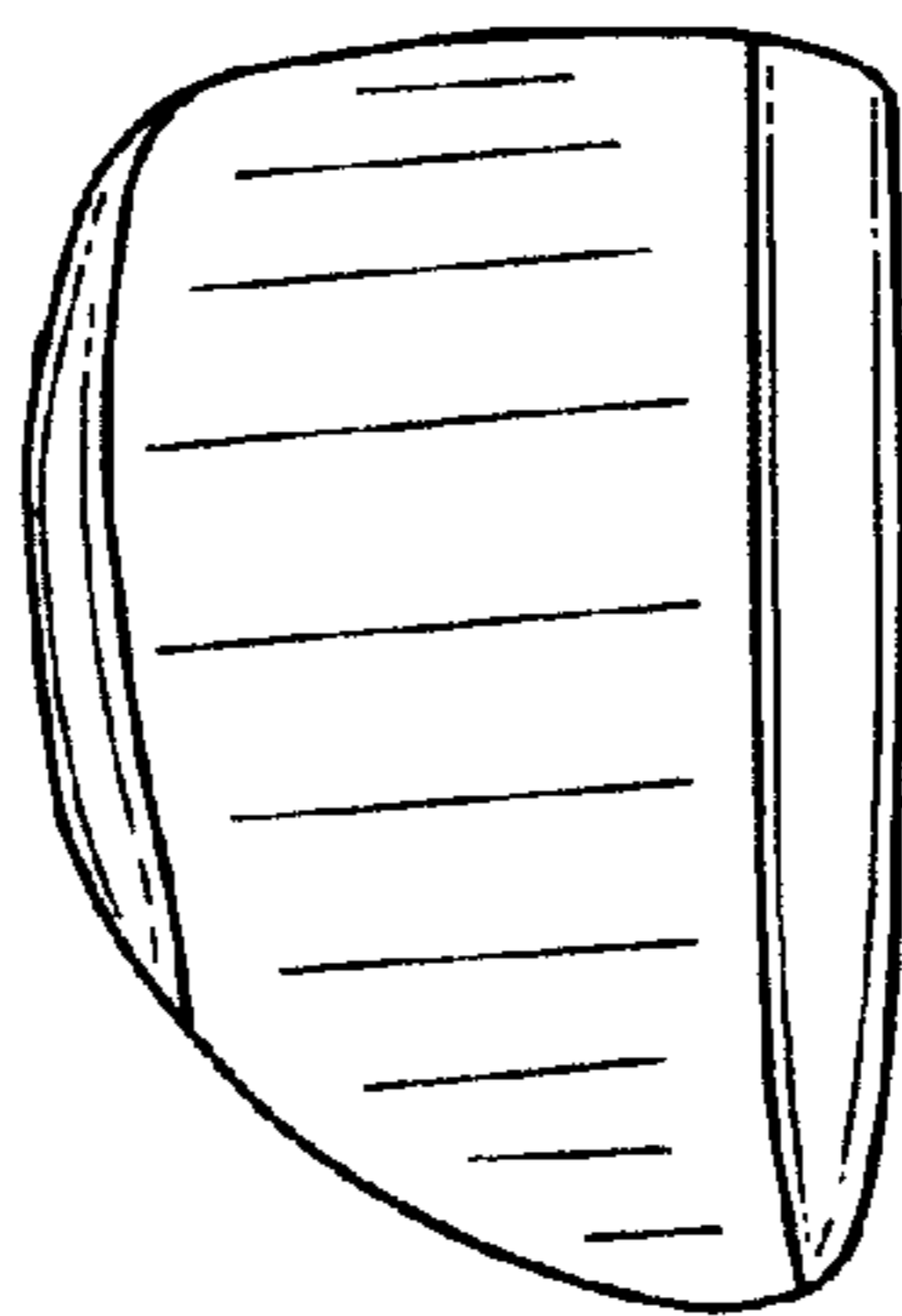

FIG. 20

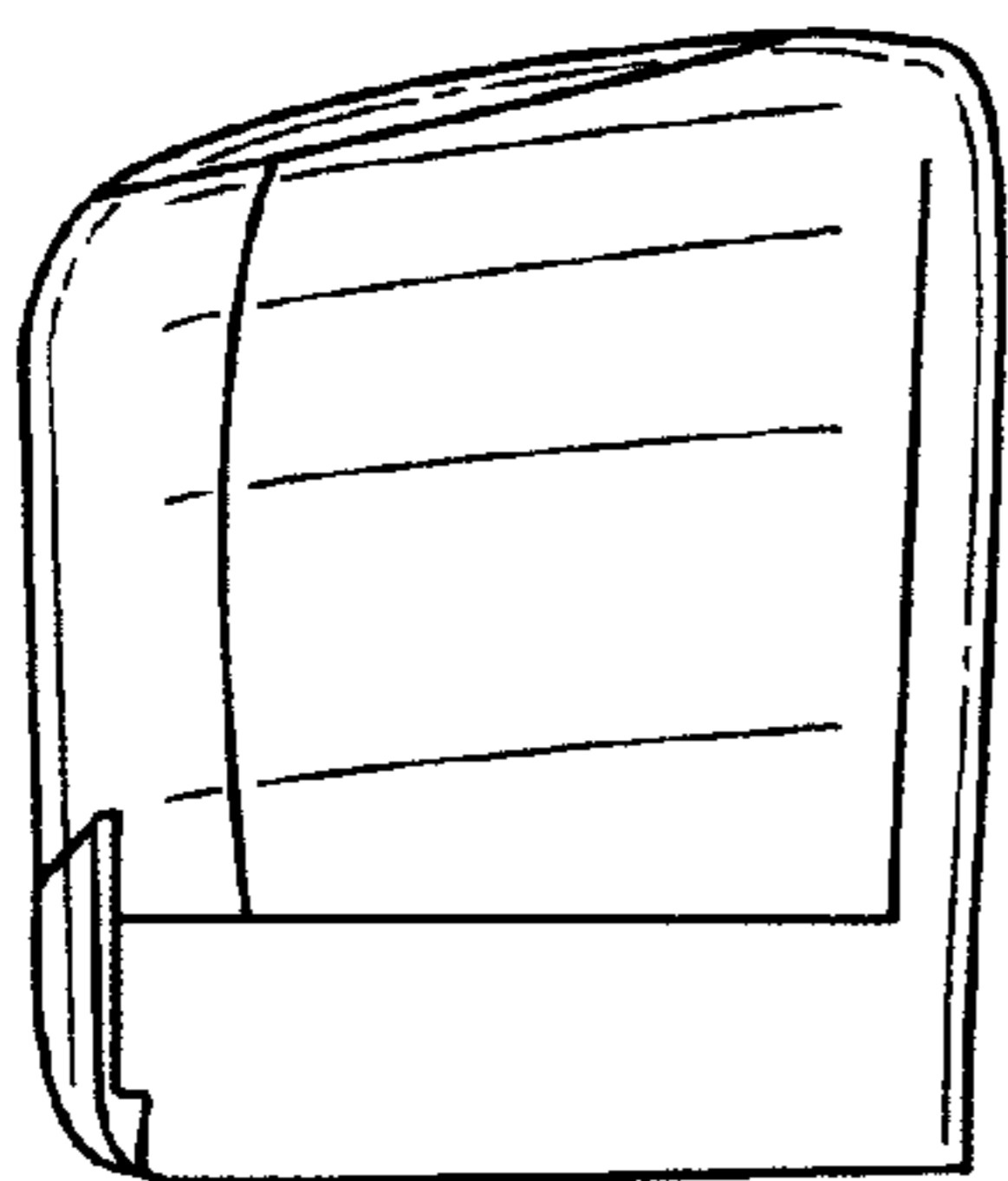

FIG. 21

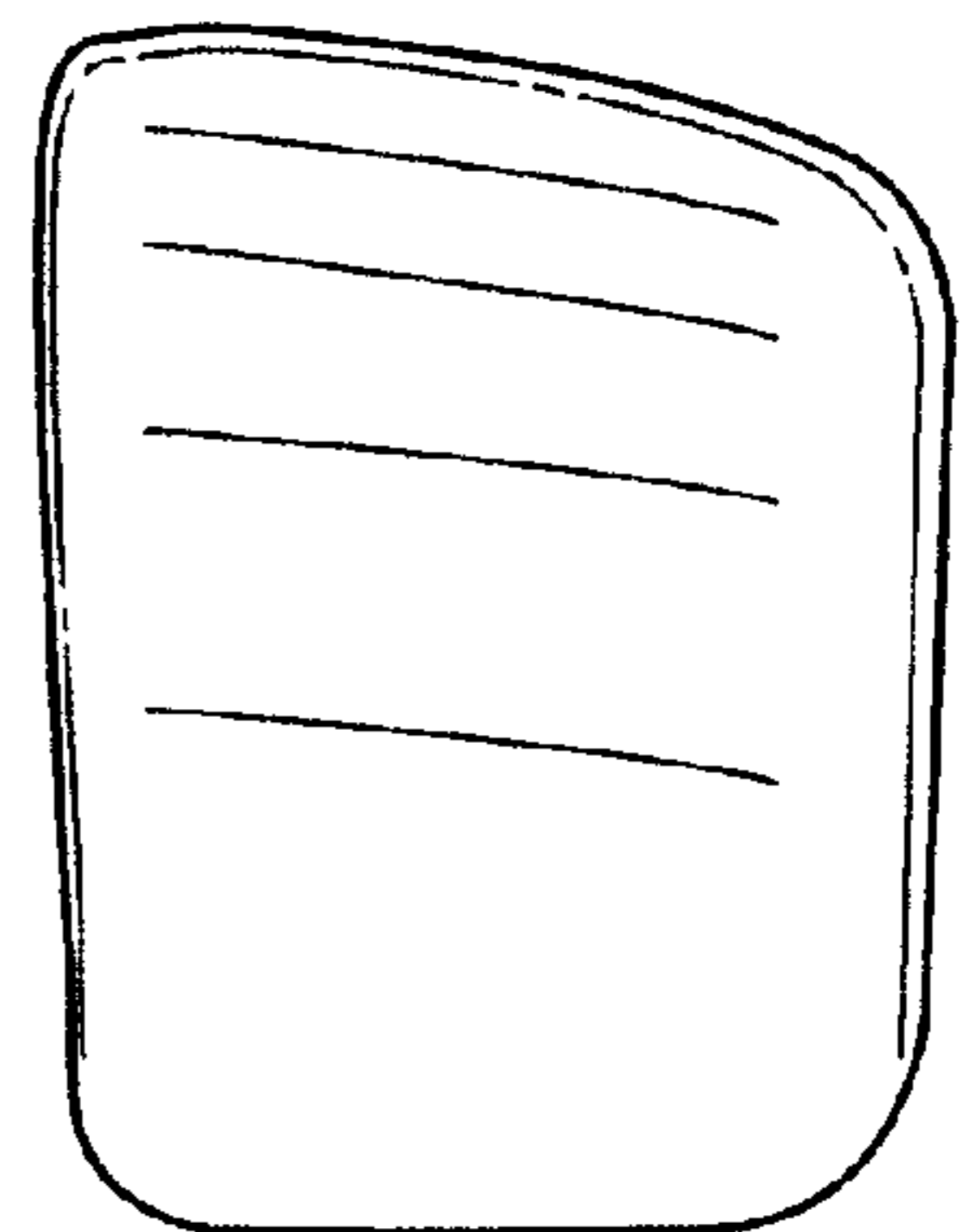

FIG. 22